

Received April 25, 2020, accepted May 4, 2020, date of publication May 8, 2020, date of current version May 22, 2020.

Digital Object Identifier 10.1109/ACCESS.2020.2993468

Retrodirective Antenna for Inter-Satellite Data Transmission

XIAOLI WEI^{1,2,3}, LIANXING HE^{1,2}, AND LEI CHEN⁴, (Member, IEEE)

¹Institute of Satellite Electronics, Innovation Academy for Microsatellites of CAS, Shanghai 201210, China

²School of Information Science and Technology, ShanghaiTech University, Shanghai 201210, China

³University of Chinese Academy of Sciences, Beijing 100049, China

⁴School of Electronic Engineering, Xidian University, Xi'an 710071, China

Corresponding author: Lianxing He (13816474811@139.com)

This work was supported by the National Natural Science Foundation under Grant 61671304.

ABSTRACT A new X-band retrodirective antenna based on superheterodyne mixer and phase conjugating technology is proposed for inter-satellite data transmission in this paper. The novel phase conjugating circuit, utilizing the reciprocity of the passive mixers, achieves high RF-IF and LO-IF isolations, high communication link gain, and a very compact low profile layout with all antenna elements and circuit components arranged at one common layer of a double-sided printed circuit board (PCB). Its mathematical principles of circuit design are derived, and the effect of up and down conversion loss deviation of mixers on the amplitude and phase error of the circuit, thus on the beam pointing error and the side-lobe of the antenna is discussed. A prototype of circularly polarized one dimension retrodirective antenna is fabricated, and its bistatic RCS measurement in an anechoic chamber is implemented to verify the effectiveness of the proposed antenna array. The results show that, within the scanning range from -30° to $+30^\circ$, the array has good retrodirective performance. The proposed antenna would be a good choice for the inter-satellite data transmission inside a distributed satellite cluster.

INDEX TERMS Low profile, phase conjugating, retrodirective antenna, satellite-borne.

I. INTRODUCTION

There has been considerable interest focused on satellite communication in recent years, due to its advantages of wide communication coverage and convenient implementation of multiple access communication. Compared to the conventional large satellites, modern microsatellites (including nanosatellites ($\sim 10\text{kg}$) and picosatellites ($\sim 1\text{kg}$)) have the merits of small volumes, low mass, low power-consumption, short development cycle (from the proposal to final launch) and low cost. The development of microsatellites has become a research hotspot in recent years [1]–[8]. So designing an antenna adapted to the microsatellites application within limited weight and power consumption has become the primary consideration in its communication system. As the environment of inter-satellite data transmission is dynamic, complex, and changeable, a reliable crosslink with other satellites in a distributed satellite cluster or a constellation without prior knowledge of their positions has been a big challenge for

the microsatellites where the resources such as dimension, weight, and power consumption are extremely limited.

One evident choice for crosslinking satellites that require constant repositioning is using an omnidirectional antenna [9]–[13]. However, the omnidirectional antenna has the following two problems. Firstly, there is a security problem due to the high probability of eavesdropping by unauthorized ground stations and near satellites within the range of the satellite cluster. Secondly, the omnidirectional antenna is inefficient, as the power is radiated in all directions rather than to the target in a concentrated way. To improve the power efficiency and security, the conventional phased array antenna seems to be another candidate due to its convenient beam-steering capability. However, this kind of antenna normally has complicated phase shift, feed network, and a large number of transmitting and receiving modules which lead to large volume, weight, and power consumption, so it is not suitable for the above-mentioned microsatellite applications.

An attractive alternative for dynamic beam steering is a retrodirective antenna. It has the merits of low cost, low power-consumption, anti-jamming, and anti-eavesdropping, [14]–[20]. Retrodirective antennas can automatically track

The associate editor coordinating the review of this manuscript and approving it for publication was Tutku Karacolak.

the beam direction without the prior incoming wave position information. In other words, the beam is steered in the direction of the source that permits secure data transmission between satellites in space. The self-steering ability can be implemented without complicated phase-shift and feed networks in the conventional phased arrays or signal processing modules in the smart antennas. While three main techniques including corner reflectors, Van Atta arrays, and phase conjugating arrays are all capable of achieving retrodirectivity, the phase conjugating array technique is ideal for secure satellite crosslinks among them [21]. Among different methods to configure phase conjugating circuits, the heterodyne technique using mixers is mainly considered due to its convenient signal loading capability in this paper. As for the heterodyne technology based on the mixers, there are mainly two kinds of techniques to implement the phase conjugation, one is using its intermediate frequency (IF), another is using its local oscillator (LO) with its frequency as twice of the RF. In the heterodyne technique using an IF [22], normally two mixers are used for each channel to produce the phase conjugating signal. One of the mixers is used to mix a RF signal down to an IF with a relatively low frequency, and the other mixes the IF with a different LO signal for reradiation. The disadvantage of this method is that the signal needs to suffer conversion loss twice caused by two mixers. Besides, two local oscillators are also needed, and this will increase the total weight and power requirement. To reduce the number of mixers and local oscillators, the heterodyne technique using a LO with its frequency as twice the RF is a good choice [23]–[30]. In this case, the retrodirective IF signal has the same frequency as the incident RF signal, so the RF-IF isolation problem has become a key consideration in the circuit design. Several isolation techniques are proposed in previous work like frequency offset [24], polarization diversity [25], directional couplers [26], balanced mixers [27], and delay lines [28], etc. The coupler structure is used in this paper due to its easy implementation. Furthermore, in the heterodyne phase conjugating system, appropriate mixers are also important for circuit property. Conventional isolation techniques using couplers normally choose field-effect transistor (FET) mixers in the circuit due to its low distortion and conversion loss. The FET mixer often adopts a common source configuration. The RF and IF signals share the drain terminal of the FET whereas the gate terminal is connected to the local oscillator (LO) [29]. Fig.1 shows a conventional retrodirective system with two separate antennas connected to one unidirectional passive mixer to improve the isolation. As a three-port device, the conventional unidirectional passive mixer is hard to construct a co-planar circuit due to its complicated layout which may cause probable impedance mismatch, extra via connection, and high profile. Furthermore, as a two-port active device, the FET mixer needs external DC bias which leads to a complicated extra circuit and high power consumption.

In this paper, to fulfill the low profile and light-weight demand in some satellite-borne applications, a novel circularly polarized (CP) phase conjugating array (PCA) based on

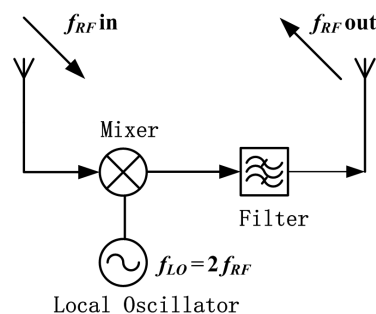

FIGURE 1. Schematic of the conventional separate antenna retrodirective system only using its unidirectional conversion ability of mixers.

the reciprocity of the passive diode mixer is proposed. The circuit first utilizes a 90° hybrid coupler for each antenna element to achieve high RF-IF isolation. Then, different from conventional PCA and the FET mixer technology, the passive diode mixer with the reciprocal property is utilized in the design. The array can reuse up and down conversion in just one mixer, which enables each transmit-receive sharing antenna element to receive and to retransmit the signal at the same time by sharing a common channel. It allows all antenna elements and circuit components to arrange in just one layer of a double-sided printed circuit board (PCB) as well. Therefore, the design proposed in this paper is simpler and more compact, and it is thus especially suitable for highly integrated satellite-borne applications with the merits of low profile and light-weight. Furthermore, the mixer with comparatively low conversion loss is also chosen to achieve a high communication link gain. Additionally, as a fully passive system, the proposed PCA has a powerful competitive benefit in power consumption over other conventional phased arrays or smart antennas based on the adaptive beam-forming algorithm.

II. WORKING PRINCIPLES

A. SYSTEM CONCEPT AND WORKING PRICIPLES

Although retrodirective antenna technology has been widely studied since the Mid-19th century, designing for microsatellite applications presents new challenges. Since these satellites are too small to have attitude control systems, it is impossible to know the orientation of each satellite. So these microsatellites require antennas not only to be self-steering but also to be miniaturized, light weight, and low profile.

To meet the demand for satellite-borne integration requirements, sometimes all antenna elements and components in the circuit need to be arranged at the same layer of a double-sided PCB. A new simple PCA utilizing the reciprocity of passive mixers is proposed in this paper, and the circuit structure for one antenna element is shown in Fig. 2. With the reciprocity of passive mixers, RF signal and retransmitted IF signal can go through on the common channel and the size of total PCB can be greatly reduced. At the same time, a 90° hybrid coupler is also used to achieve high RF-IF isolation, which has been illustrated as a feasible scheme according to [30]. The working principles are shown as follows.

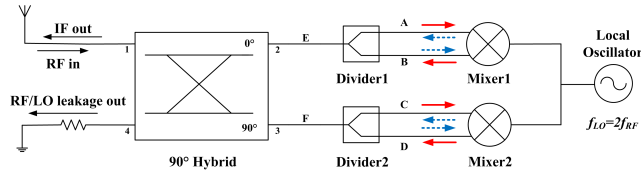

FIGURE 2. Block diagram of the proposed phase conjugating array (PCA) using the reciprocity of passive mixers in this paper.

As shown in Fig. 2, each antenna element from the transeiving array is connected to port 1 of the 90° hybrid coupler. Firstly, we suppose the angular frequency of the RF signal is ω , and the angular frequency of the LO signal is 2ω . The RF incident signal can be expressed as $V_{RF}(t) = V_{RF} \cos(\omega t + \varphi_r)$, where, V_{RF} and φ_r are the amplitude and the initial phase of the incident RF signal, respectively. The LO incident signal can be expressed as $V_{LO}(t) = V_{LO} \cos(2\omega t)$, where, V_{LO} is the amplitude of the LO signal. Then the incident RF signal at port 1 is divided into two signals with a 90° phase difference by the 90° hybrid coupler. The expressions of incident signals at port 2 and port 3 are

$$V_2(t) = (1/2) V_{RF} \cos(\omega t + \varphi_r) \quad (1)$$

$$V_3(t) = (1/2) V_{RF} \cos(\omega t + \varphi_r - 90^\circ) \quad (2)$$

The signal at port 2 is divided into two in-phase signals with equal amplitude by the Wilkinson divider. The incident signal in branch A mixes with the LO signal and produces the output retransmitted signal going through the branch B. Simultaneously, the incident signal in branch B mixes with the LO signal and produces the output retransmitted signal going through the branch A. The voltage flow path of the signal at port 3 of the 90° hybrid coupler is the same as the signal of port 2. By innovatively utilizing the reciprocity of passive mixers, both RF signals and retransmitted IF signals can go through on the same channel. In other words, the novel use of the reciprocal passive mixer enables the mixing process of branch A and branch B to operate simultaneously in just one mixer. Therefore, the routing difficulty of a three-port device can be solved by connecting input and output ports of the mixer to a microstrip divider, and the proposed co-planar layout can be much simpler than conventional circuit structures using FET mixers with inevitable DC bias. After the mixing operation, the initial retrodirective signals of four branches are characterized by the following expressions:

$$\begin{aligned} V_{A_i}(t) &= V_{B_i}(t) \\ &= (1/4) V_{RF} \cos(\omega t + \varphi_r) \times V_{LO} \cos(2\omega t) \\ &= (1/8) V_{RF} V_{LO} \cos(3\omega t + \varphi_r) \\ &\quad + (1/8) V_{RF} V_{LO} \cos(\omega t - \varphi_r) \end{aligned} \quad (3)$$

$$\begin{aligned} V_{C_i}(t) &= V_{D_i}(t) \\ &= (1/4) V_{RF} \cos(\omega t + \varphi_r - 90^\circ) \times V_{LO} \cos(2\omega t) \\ &= (1/8) V_{RF} V_{LO} \cos(3\omega t + \varphi_r - 90^\circ) \\ &\quad + (1/8) V_{RF} V_{LO} \cos(\omega t - \varphi_r + 90^\circ) \end{aligned} \quad (4)$$

where, $V_{A_i}(t)$, $V_{B_i}(t)$, $V_{C_i}(t)$, and $V_{D_i}(t)$ are retrodirective signals in branch A, B, C, and D, respectively.

The expected output signals are the term with an underline in (3) and (4), respectively. The final retransmitted IF signals at port 1 ($V_{1_r}(t)$) and port 4 ($V_{4_r}(t)$) after dividers and the 90° hybrid coupler are characterized by the following expressions:

$$\begin{aligned} V_{1_r}(t) &= (1/4) V_{RF} V_{LO} \cos(\omega t - \varphi_r) \\ &\quad + (1/4) V_{RF} V_{LO} \cos[(\omega t - \varphi_r + 90^\circ) - 90^\circ] \\ &= (1/2) V_{RF} V_{LO} \cos(\omega t - \varphi_r) \end{aligned} \quad (5)$$

$$\begin{aligned} V_{4_r}(t) &= (1/4) V_{RF} V_{LO} \cos[(\omega t - \varphi_r) - 90^\circ] \\ &\quad + (1/4) V_{RF} V_{LO} \cos(\omega t - \varphi_r + 90^\circ) \\ &= 0 \end{aligned} \quad (6)$$

Equation (5) indicates that the generated phase conjugated signal combines in phase at port 1 of the coupler. In terms of phase φ_r of the RF signal, the retransmitted signal exhibits the same frequency as the incident signal, but phase conjugated. Thus the antenna can track the interrogation signal without any prior knowledge of its direction. Equation (6) shows that the RF leakage from branch E and F cancel each other at port 4 of the coupler. Furthermore, since the frequency of RF signal is half of the LO signal, the LO signals from two channels appear out of phase when combined at port 4, and it thus also cancels the LO leakage to provide good LO-IF isolation. Port 4 is terminated with a 50 Ω matched load to dump the RF and LO leakage. Therefore, this circuit structure can significantly improve the RF-IF and LO-IF isolation, reducing undesired interference and increasing the working efficiency of the antenna.

B. EFFECT OF CONVERSION LOSS DEVIATION ON ANTENNA PERFORMANCES

Theoretically, a perfect phase conjugated signal can be obtained and it thus ensures an accurate beam pointing of retrodirective antenna according to the mathematical derivation mentioned above. However, in the practical implementation of a phase conjugating circuit, a slight beam pointing error (BPE) is still inevitable. Many factors affect the array beam pointing accuracy such as the presence of RF leakage in the retransmitted signal, the length of the array and the inconsistency of physical properties between circuit branches, which have been extensively analyzed [31]–[34]. Since the reciprocity of passive mixers is utilized in our design, its discrepancy on conversion loss between the up and down conversion of the mixer would probably cause the amplitude/phase error of the circuit and thus influence the BPE of the array further. So the effect of conversion loss deviation on the antenna performances needs to be evaluated in advance.

To evaluate the effect of conversion loss deviation on the amplitude and phase error of the circuit, we first construct the phase conjugating circuit in Agilent Advanced Design System (ADS) and arbitrarily set the conversion deviation

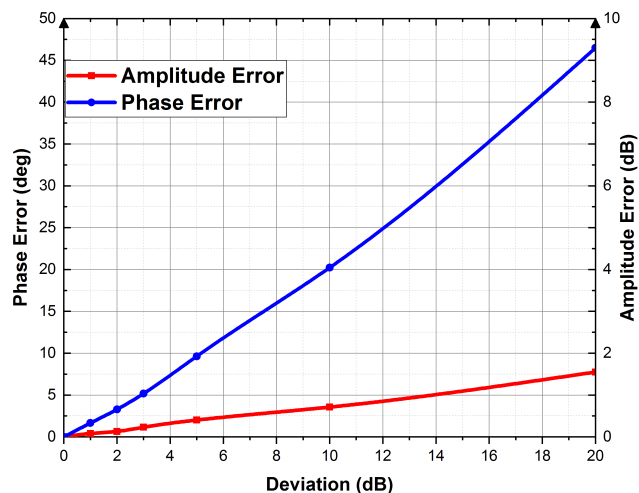

FIGURE 3. The amplitude and phase error versus the deviation value between up and down conversion loss of mixers.

between up and down conversion of mixers as 1dB, 2dB, 3dB, 5dB, 10dB, and 20dB, respectively. Fig. 3 shows the simulation results of amplitude and phase error versus the deviation.

Fig. 3 shows that with the increase of the deviation, the amplitude error and the phase error increase as well, and the phase error in the circuit increases faster than the amplitude error. These two kinds of errors normally have influences on the performance of antennas including the beam pointing error and the side-lobe property. Therefore, further analysis of the radiation patterns under the effect of phase and amplitude errors is necessary. Fig. 4 shows radiation patterns influenced by the deviation between up and down conversion loss at 1dB, 2dB, 3dB, 5dB, 10dB, and 20dB, respectively. The radiation pattern without deviation (0dB) is set as an ideal case for reference.

In Fig. 4 (a) and 4 (b), one can see that the radiation patterns with the deviation of 1dB and 2dB are approximately the same as the ideal pattern. When the deviation increases to 3dB and 5dB, as shown in Fig. 4 (c) and 4 (d), it is still approximately no effect on its main lobe and BPE performance, but the influence on side-lobe property increases gradually. As shown in Fig. 4 (e) and 4 (f), when the deviation reaches a very high level such as 10dB and 20dB, the BPE of the main lobe is getting obviously high and its side-lobe performance is getting even worse. The results indicate that the antenna has relatively good beam pointing accuracy and side-lobe performance within the conversion loss deviation of 2dB, whereas radiation patterns have higher BPE and worse side-lobe performance when the conversion deviation is more than 10dB.

III. DESIGN

A. ANTENNA DESIGN

The configuration of the antenna array is shown in Fig. 5. The one-dimension retrodirective antenna array consists of 4 planar microstrip antenna elements. Left-hand circular polarization (LHCP) is achieved with a 45° chamfer at the

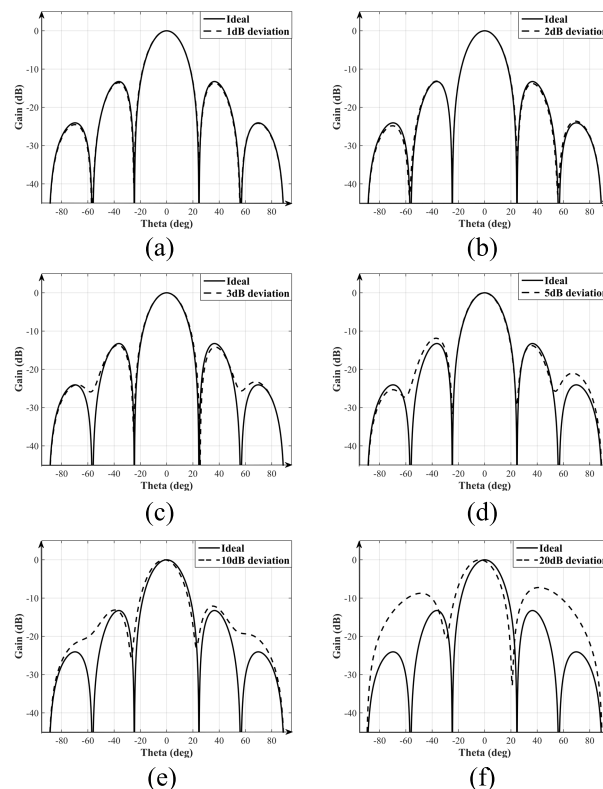

FIGURE 4. Simulation results on radiation patterns under the mixing conversion loss deviation of (a) 1dB, (b) 2dB, (c) 3dB, (d) 5dB, (e) 10dB, and (f) 20dB.

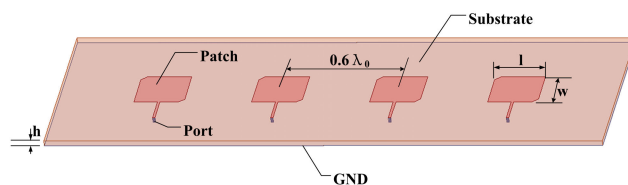

FIGURE 5. Circularly polarized four-element microstrip patch antenna array designed using ANSYS HFSS. The resonant frequency is 8.1GHz.

upper left and the lower right of each element patch, respectively. The size of each patch element is 9.4 mm × 9.4 mm ($l = w = 9.4$ mm), and the element spacing is $0.6 \lambda_0$ (λ_0 is the free-space wavelength at the center frequency of operating band). The antenna substrate is Rogers 4350B with a relative permittivity of 3.48, a loss tangent of 0.002, and a thickness of $h = 0.508$ mm.

Fig. 6 shows the active S-parameters of the designed patch array obtained from the simulation software of ANSYS HFSS. Active S-parameters at four ports are all below -10 dB within the working bandwidth of 460 MHz (from 7.79 GHz to 8.25 GHz), this indicates a comparatively low return loss and good impedance match.

B. CIRCUIT CONFIGURATION

The phase conjugating circuit consists of three main components including the 90° hybrid coupler, dividers, and mixers. Fig. 7 shows the PCB layout configuration of the proposed

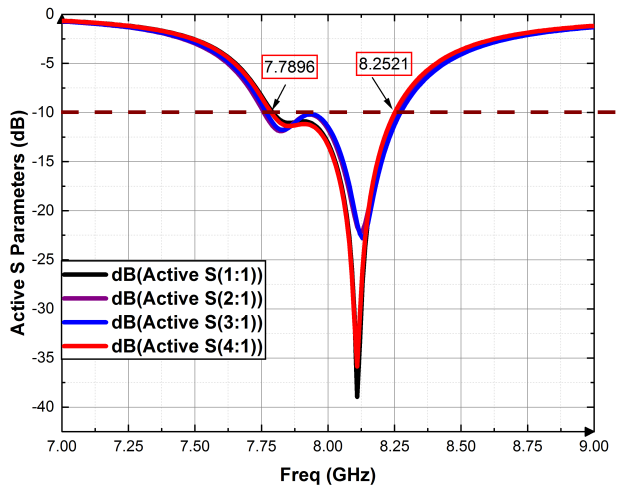

FIGURE 6. The active S parameters of the proposed patch array.

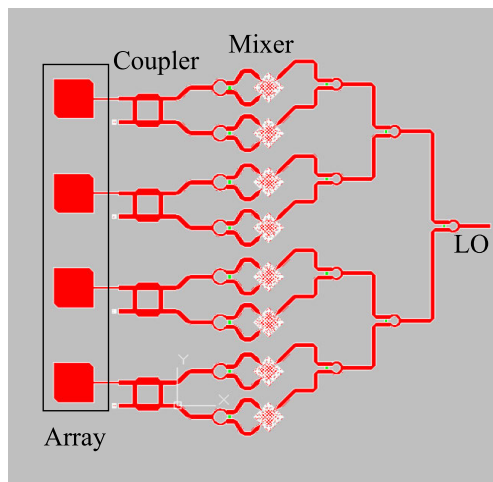

FIGURE 7. PCB layout of the proposed four-element array.

antenna. The LO port provides the LO power and the RF signal inputs from the patch array. Through this structure, the circuit can easily produce a retrodirective IF signal with the same frequency as the input RF signal but phase conjugated.

The 90° hybrid coupler with a microstrip structure can improve the RF-IF and LO-IF isolation very well. The divider adopts the Wilkinson microstrip structure, which can divide the power of the source equally into branches with high isolation between them. The Wilkinson divider can realize not only power dividing but also power combining. This important feature enables incoming signals and retransmitted signals to go through on the same channel.

The mixer which we used is BW377SM5H made by China Electronics Technology Group Corporation (CETC) 13th Institute. It is a GaAs passive double-balanced chip mixer, which can operate at a wideband without external DC bias. The LO/RF frequency range covers 6~18 GHz, while the IF frequency ranges from DC to 8.5 GHz. The in-band conversion loss is less than 10dB with good temperature performance and stability. It is also appropriate for HMIC (Hybrid Microwave Integrated Circuit) and MCM (Multichip

TABLE 1. The circuit simulation result by Agilent ADS.

Frequency(GHz)	$V_{rf}(V)/\varphi_{rf}(\text{deg})$	$V_{out}(V)/\varphi_{out}(\text{deg})$
0.000	0.000/0.000	1.525E-16/0.000
0.200	0.000/0.000	0.000/0.000
7.700	0.000/0.000	4.952E-16/32.233
7.900	10.000/90.000	0.000/0.000
8.000	10.000/90.000	9.997/-90.000
8.100	0.000/0.000	9.997/-90.000
15.800	0.000/0.000	4.618E-16/118.643
16.000	0.000/0.000	0.000/0.000
16.200	0.000/0.000	3.522E-16/130.073
23.700	0.000/0.000	0.000/0.000
23.900	0.000/0.000	4.988E-16/-42.844
32.000	0.000/0.000	1.620E-16/120.747
40.100	0.000/0.000	3.554E-16/-20.576
47.800	0.000/0.000	4.269E-16/-131.667

Module). As for the most important feature of the mixer, the deviation between up and down conversion loss is within 1dB, its good reciprocity would ensure a good antenna performance according to the analysis results of Section II-B.

IV. EXPERIMENTAL RESULTS

The designed circuit, as shown in Fig. 7, is validated through simulation using Agilent ADS in advance before fabrication to ensure its phase conjugation property. In Table. 1, V_{rf} and V_{out} are the amplitude of the incident RF signal and retroreflected IF signal, respectively. φ_{rf} and φ_{out} are the phase of the incident RF signal and retrodirective IF signal, respectively. The components in the circuit are set to be ideal lossless. The phase differences between incident RF signal and retrodirective IF signal under the designed frequencies of 7.9 GHz, 8.0 GHz, and 8.1 GHz, as shown in Table. 1, ensure a very good phase conjugation characteristic of the circuit. The minor deviations in amplitudes are probably caused by the simulation system and parameter setting.

The bistatic RCS measurement in an anechoic chamber is implemented to verify the effectiveness of the proposed antenna array. Fig. 9 illustrates the typical experimental setup for characterizing the retrodirective array. A stationary rectangular horn antenna provides the RF interrogating signal at a certain angle α toward the prototype shown in Fig. 8. Once the RF signal is incident on the prototype, the retrodirective IF signal is reflected ideally in the same direction as the RF horn. A second rectangular horn, scanned over a 60° range, picks up this reflected IF signal. A characteristic peak in the pattern should occur in the same direction of the source.

Since the incident RF and retrodirective IF have the same frequency, the leakage from the RF horn to the IF horn is always inevitable. In practice, this problem can be overcome by slightly offsetting the frequencies so that the two signals can be resolved on a spectrum analyzer. Therefore, the following frequencies were used: LO signal of 16 GHz, RF signal of 7.9 GHz, and IF signal of 8.1 GHz. During the measurement, a signal generator is used to provide a 16-GHz local oscillator signal, a vector network analyzer provides a 7.9-GHz transmitting RF signal, and a spectrum analyzer is used to receive the 8.1-GHz retrodirective signal.

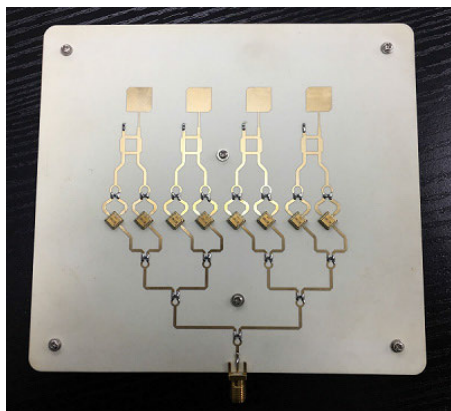

FIGURE 8. The one-dimension antenna array prototype.

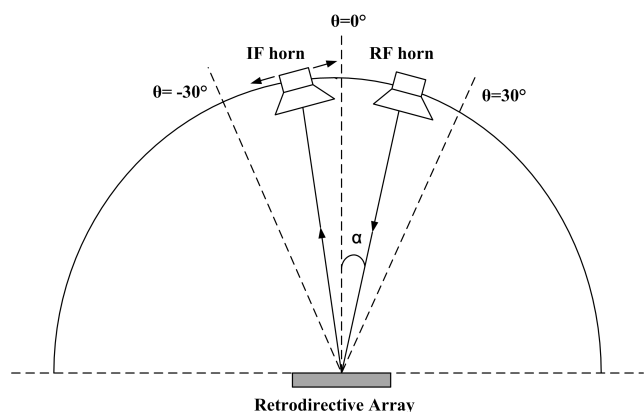

FIGURE 9. Experimental setup for a bistatic RCS measurement.

Bistatic RCS results in Fig. 10 show that the maximum amplitudes of retrodirective receiving signals appear at the direction of the interrogation signals with the position at -30° , -15° , 0° , 15° , and 30° , respectively. Interrogation signals from different positions can be obtained by changing the transmitting angle α toward the prototype. The beam pointing errors for five measured positions are all less than 3° , which indicates a good retrodirectivity. Small deviation compared to the theoretical value probably comes from the mismatching of amplitude and phase between circuit branches, the measurement environment, and the interference between the antenna element and microstrip lines, etc.

The experimental results indicate that the proposed antenna can obtain good retrodirective performance. For future work, as the incident signal is usually weak in the space, amplifiers will be considered placing in the circuit reasonably to amplify the signal power and increase the communication distance. Furthermore, space-level substrate materials and chip mixers will also be adopted to adapt the practical satellite-borne application with the scheme of overall circuit design nearly unchanged. The modified antenna will handle the complex space environment better with improved properties such as the high-low temperature property, anti-radiation, and anti-Single Event Upset (SEU), etc.

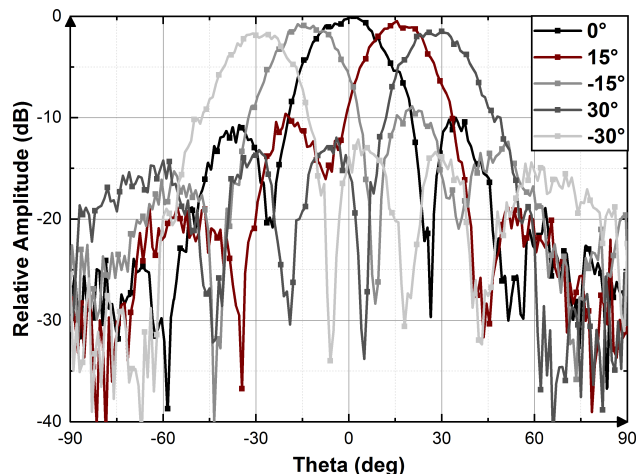

FIGURE 10. The measured result of bistatic RCS with the source positioned at -30° , -15° , 0° , 15° , and 30° , respectively.

V. CONCLUSION

A new X-band retrodirective antenna based on superheterodyne mixer and phase conjugating technology is developed in this paper. The novel phase conjugating circuit, utilizing the reciprocity of the passive mixers, provides good RF-IF and LO-IF isolations and enables a very compact low profile layout and high communication link gain. The bistatic radar cross-section (RCS) measurements on the one-dimension retrodirective antenna prototype show that, within the scanning range from -30° to $+30^\circ$, the antenna array has good retrodirective performance with the beam pointing error (BPE) less than 3° . The developed retrodirective antenna has the merits of low profile, light weight, and low power-consumption, compared with other counterparts such as conventional phased arrays or smart antennas. It is thus especially suitable for the microsatellite applications where the resources such as dimension, weight, and power consumption are extremely limited. The inherent characteristics of retrodirective antenna including anti-eavesdropping and quick self-steering also permit a reliable and secure inter-satellite data transmission in a distributed satellite cluster or a constellation.

REFERENCES

- [1] H. Tsuji, T. Okura, T. Kan, T. Takahashi, and M. Toyoshima, "Ka-band airborne array antenna development for satellite communications," in *Proc. 21st Int. Symp. Wireless Pers. Multimedia Commun. (WPMC)*, Chiang Rai, Thailand, Nov. 2018, pp. 443–446.
- [2] S. Gao, K. Clark, M. Unwin, J. Zackrisson, W. A. Shiroma, J. M. Akagi, K. Maynard, P. Garner, L. Boccia, G. Amendola, G. Massa, C. Underwood, M. Brenchley, M. Pointer, and M. N. Sweeting, "Antennas for modern small satellites," *IEEE Antennas Propag. Mag.*, vol. 51, no. 4, pp. 40–56, Aug. 2009.
- [3] B. T. Murakami, J. D. Roque, S. S. Sung, G. S. Shiroma, R. Y. Miyamoto, and W. A. Shiroma, "A quadruple subharmonic phase-conjugating array for secure picosatellite crosslinks," in *IEEE MTT-S Int. Microw. Symp. Dig.*, Fort Worth, TX, USA, Oct. 2004, pp. 1687–1690.
- [4] A. Bellion, K. Elis, and S. De Gaetano, "New compact S-band antenna for nanosatellite teleMetry and teleCommand applications—eyesat program," in *Proc. 10th Eur. Conf. Antennas Propag. (EuCAP)*, Apr. 2016, pp. 1–5.
- [5] M. J. Veljovic and A. K. Skrivervik, "Patch antenna system for cubeSats in L band," in *Proc. 13th EuCAP*, Krakow, Poland, 2019, pp. 1–5.

- [6] J. Puig-Suari, C. Turner, and W. Ahlgren, "Development of the standard CubeSat deployer and a CubeSat class PicoSatellite," in *Proc. IEEE Aerosp. Conf. Process.*, Big Sky, MT, USA, Jan. 2001, pp. 1347–1353.
- [7] V. A. Juarez-Ortiz and R. Perea-Tamayo, "Design of a C-band high gain microstrip antenna array for CubeSat standard," in *IEEE MTT-S Int. Microw. Symp. Dig.*, Arequipa, Peru, Dec. 2018, pp. 1–3.
- [8] Y. Tawk, "Physically controlled CubeSat antennas with an adaptive frequency operation," *IEEE Antennas Wireless Propag. Lett.*, vol. 18, no. 9, pp. 1892–1896, Sep. 2019.
- [9] K. He, S.-X. Gong, and F. Gao, "A wideband dual-band magneto-electric dipole antenna with improved feeding structure," *IEEE Antennas Wireless Propag. Lett.*, vol. 13, pp. 1729–1732, 2014.
- [10] Y. Chen, G. Li, P. Liu, L. Bian, and B. Yi, "Wideband, circularly polarized, crossed, bowtie dipole antenna for navigation satellite system," in *Proc. IEEE 2nd Adv. Inf. Technol., Electron. Autom. Control Conf. (IAEAC)*, Chongqing, China, Mar. 2017, pp. 2649–2652.
- [11] L. Chen, L. Chang, and H. Wang, "Circularly polarized cross dipole with wide beam for satellite-borne application," in *Proc. 11th Int. Symp. Antennas, Propag. EM Theory (ISAPE)*, Guilin, China, Oct. 2016, pp. 108–111.
- [12] L. Lee, I. Frasure, T. Narker, R. Marhefka, J. Sugrue, A. Terzuoli, and R. Wasky, "Tightly-packed crossed-dipole array for L-band satellite communications," in *Proc. IEEE Int. Symp. Antennas Propag. USNC/URSI Nat. Radio Sci. Meeting*, Boston, MA, USA, Jul. 2018, pp. 1417–1418.
- [13] V. Rahul, S. A. Kumar, and T. Shanmuganatham, "CPW fed slot dipole antenna with comb shape for satellite applications," in *Proc. 3rd Int. Conf. Microw. Photon. (ICMAP)*, Dhanbad, Jharkhand, Feb. 2018, pp. 1–2.
- [14] V. Fusco and N. Buchanan, "Dual-mode retrodirective/phased array," *Electron. Lett.*, vol. 45, no. 3, pp. 139–141, 2009.
- [15] R. T. Iwami, T. F. Chun, W. G. Tonaki, and W. A. Shiroma, "A power-detecting, null-scanning, retrodirective array for a CubeSat platform," in *IEEE MTT-S Int. Microw. Symp. Dig.*, Honolulu, HI, USA, Jun. 2017, pp. 662–665.
- [16] O. Malyuskin and V. F. Fusco, "Ultracompact retrodirective antenna arrays with superdirective radiation patterns," *IEEE Trans. Antennas Propag.*, vol. 64, no. 7, pp. 2923–2935, Jul. 2016.
- [17] V. F. Fusco, N. B. Buchanan, and O. Malyuskin, "Active phase conjugating lens with sub-wavelength resolution capability," *IEEE Trans. Antennas Propag.*, vol. 58, no. 3, pp. 798–808, Mar. 2010.
- [18] K. M. K. H. Leong, R. Y. Miyamoto, and T. Itoh, "Moving forward in retrodirective antenna arrays," *IEEE Potentials*, vol. 22, no. 3, pp. 16–21, Aug. 2003.
- [19] P. D. H. Re, S. K. Podilchak, S. Rotenberg, G. Goussetis, and J. Lee, "Retrodirective antenna array for circularly polarized wireless power transmission," in *Proc. 11th Eur. Conf. Antennas Propag. (EUCAP)*, Paris, France, Mar. 2017, pp. 891–895.
- [20] N. B. Buchanan, V. F. Fusco, and M. van der Vorst, "SATCOM retrodirective array," *IEEE Trans. Microw. Theory Techn.*, vol. 64, no. 5, pp. 1614–1621, May 2016.
- [21] K. S. B. Yau, "Development of a passive retrodirective van Atta array reflector at X-band," in *Proc. Int. Conf. Radar*, Adelaide, SA, USA, Sep. 2013, pp. 398–402.
- [22] R. Gomes, P. Paraiso, T. Fernandes, and R. Caldeirinha, "Passive phase conjugating array using FR4," in *Proc. Loughborough Antennas Propag. Conf. (LAPC)*, Loughborough, U.K., Nov. 2014, pp. 329–332.
- [23] R. Y. Miyamoto and T. Itoh, "Retrodirective arrays for wireless communications," *IEEE Microw. Mag.*, vol. 3, no. 1, pp. 71–79, Mar. 2002.
- [24] A.-M. Yao, W. Wu, and D.-G. Fang, "Frequency diverse phase-conjugating retrodirective array with simultaneous range-focusing capability for multi-targets," in *Proc. Asia-Pacific Microw. Conf. (APMC)*, Nanjing, China, Dec. 2015, pp. 1–3.
- [25] Y. Dong, S.-W. Dong, L. Yang, Y. Wang, and Z. Li, "A polarization auto-matching retrodirective method," in *Proc. 3rd Asia-Pacific Conf. Antennas Propag.*, Harbin, China, Jul. 2014, pp. 367–368.
- [26] C. W. Pobanz and T. Itoh, "A conformal retrodirective array for radar applications using a heterodyne phased scattering element," in *IEEE MTT-S Int. Microw. Symp. Dig.*, vol. 2, May 1995, pp. 905–908.
- [27] R. Y. Miyamoto, Y. Qian, and T. Itoh, "A retrodirective array using balanced quasi-optical FET mixers with conversion gain," in *IEEE MTT-S Int. Microw. Symp. Dig.*, vol. 2, Jun. 1999, pp. 655–658.
- [28] L. Chiu, Q. Xue, and C. H. Chan, "A 4-Element balanced retrodirective array for direct conversion transmitter," *IEEE Trans. Antennas Propag.*, vol. 59, no. 4, pp. 1185–1190, Apr. 2011.
- [29] L. Chiu, Q. Xue, and C. Hou Chan, "Phase-conjugated arrays using low conversion-loss resistive phase-conjugating mixers and stub-loaded patch antennas," *IEEE Trans. Microw. Theory Techn.*, vol. 56, no. 8, pp. 1764–1773, Aug. 2008.
- [30] D. Goshi, K. Leong, and T. Itoh, "A scheme for hardware reduction in wireless retrodirective transponders," in *IEEE MTT-S Int. Microw. Symp. Dig.*, San Francisco, CA, USA, Aug. 2006, pp. 626–629.
- [31] B. Yen Toh, V. F. Fusco, and N. B. Buchanan, "Assessment of performance limitations of planar retrodirective arrays," *IEEE Trans. Antennas Propag.*, vol. 50, no. 10, pp. 1425–1432, Oct. 2002.
- [32] V. F. Fusco, "Retrodirective array techniques for ACC vehicular augmentation," in *Proc. IEE Colloq. Antennas Automotives*, London, U.K., 2000, pp. 1–6.
- [33] V. F. Fusco and N. Buchanan, "Retrodirective array performance in the presence of near field obstructions," *IEEE Trans. Antennas Propag.*, vol. 58, no. 3, pp. 982–986, Mar. 2010.
- [34] C. T. Rodenbeck and K. Chang, "A limitation on the small-scale demonstration of retrodirective microwave power transmission from the solar power satellite," *IEEE Antennas Propag. Mag.*, vol. 47, no. 4, pp. 67–72, Aug. 2005.



XIAOLI WEI was born in Anhui, China. She received the B.Eng. degree in detection guidance and control technology from the Nanjing University of Science and Technology (NJUST), Nanjing, China, in 2018. She is currently pursuing the M.S. degree in electromagnetic and microwave technology with the Innovation Academy for Microsatellites of CAS, Shanghai, China. Her current research interests include metamaterials and space-borne antennas.



LIANXING HE was born in Lianyungang, China. He received the M.S. and Ph.D. degrees from the Shanghai Institute of Ceramics, Chinese Academy of Sciences (CAS), in 1997 and 2000, respectively. He is currently working as a Research Fellow with the Innovation Academy for Microsatellites of CAS. He is also an Adjunct Professor with ShanghaiTech University. His research interests include phased array antenna, space-borne antenna, novel antenna-based on EBG/PBG, and/or metamaterials.



LEI CHEN (Member, IEEE) was born in Shaanxi, China. She received the B.E. degree in electromagnetic engineering and the Ph.D. degree in electromagnetic fields and microwave technology from Xidian University, Xi'an, China, in 2004 and 2010, respectively. She is currently an Associate Professor with the School of Electronic Engineering, Xidian University. Her current research interests include antenna arrays and microwave components.

• • •