

Received March 21, 2020, accepted April 2, 2020, date of publication April 7, 2020, date of current version May 8, 2020.

Digital Object Identifier 10.1109/ACCESS.2020.2986248

All-Optical OOK -to-QPSK Modulation Format Conversion With Wavelength Multicasting Based on Cascaded SOA Configuration

YAYA MAO¹, BO LIU¹, JIANXIN REN², XING XU², XIANGYU WU², AND LEI JIANG¹

¹Institute of Optoelectronics, Nanjing University of Information Science and Technology, Nanjing 210044, China

²School of Electronic Engineering, Beijing University of Posts and Telecommunications, Beijing 100876, China

Corresponding author: Bo Liu (bo@nuist.edu.cn)

This work was supported in part by the National Natural Science Foundation of China (NSFC) under Grant 61835005, Grant 61822507, Grant 61522501, Grant 61475024, Grant 61675004, Grant 61705107, Grant 61727817, Grant 61775098, Grant 61720106015, and Grant 61875248, in part by the National Key Research and Development Program of China under Grant 2018YFB1800901, in part by the Beijing Young Talent under Grant 2016000026833ZK15, and in part by the Fund of the State Key Laboratory of Information Photonics and Optical Communications (IPOC), Beijing University of Posts and Telecommunications (BUPT).

ABSTRACT An on-off keying (OOK) to quadrature phase shift keying (QPSK) format conversion scheme has been demonstrated in this paper. Two-channel OOK signals are converted into one-channel QPSK signal, and accompanied with a multicast function. The proposed scheme is based on a cascaded semiconductor optical amplifiers (SOA) configuration where the processes of cross phase modulation (XPM) and nonlinear polarization rotation (NPR) are properly controlled by OOK signals in each SOA. The experimental results show that after conversion, four-channel QPSK signals are successfully obtained with open eye-diagrams, and all the converted signals experience a small power penalty of less than 3.4 dB at a bit error rate (BER) of 10^{-9} compared to the original signal. In addition, the optical spectra and the constellation diagrams of the converted signal also indicate the high quality performance exhibited by the proposed format conversion scheme.

INDEX TERMS Format conversion, semiconductor optical amplifier (SOA), wavelength multicasting, nonlinear effect.

I. INTRODUCTION

Phase modulation is a promising technology when it comes to improve the performance of long-distance data transmission systems. Compared to traditional on-off keying (OOK) modulation, phase modulation has better fault tolerance and robustness for different transmission damage [1]–[3]. Among the varieties of phase modulated formats, the QPSK data format is one of the best candidates for high-capacity and long-haul backbone networks owing to its high spectral efficiency [4]–[6]. However the simple OOK modulation format is still widely used in metropolitan area network (MAN) [7]. Therefore it is likely that between the metropolitan and backbone networks, an intermediate node is needed to convert the modulation formats between quadrature phase shift keying (QPSK) and OOK signals, so as to construct a seamless

photonic networking structure in the future. When data from MAN comes to the switching node, two OOK signals of different wavelengths may need to be multiplexed into a single QPSK signal. During the past decade, various OOK to QPSK signal conversion schemes have been studied in highly nonlinear fiber (HNLF) [6], [8], [9]. However, its relatively weak nonlinear characteristics lead to its relatively long length, which does not allow integration on a compact platform. AlGaAs waveguide can perform the format conversion function similar to HNLF in shorter device interaction length, but its transmission loss is significantly high [10]. Compared with HNLF and AlGaAs waveguide, semiconductor optical amplifier is considered as a promising device for all-optical signal processing due to its high nonlinearity, small size and gain characteristics [11]–[14]. Based on the cross phase modulation (XPM) effect in SOA, various conversions between conventional OOK and binary phase shift keying (BPSK) have been reported [15], [16]. The QPSK signal can be

The associate editor coordinating the review of this manuscript and approving it for publication was Jenny Mahoney.

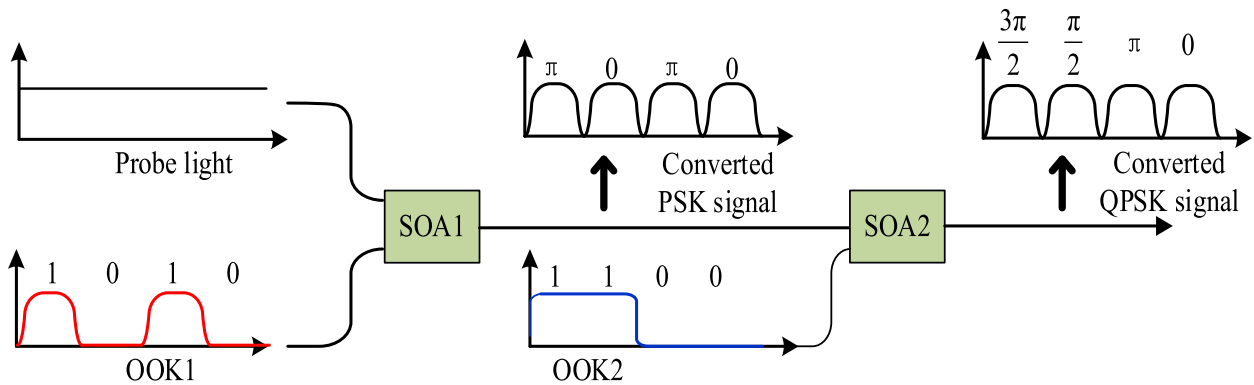

FIGURE 1. Schematic diagram of all-optical OOK to QPSK format conversion (OOK: on-off keying; SOA: semiconductor optical amplifier).

converted from two OOK signals via the XPM in semiconductor optical amplifier (SOA) [17], however, the output optical power is hard to equalize by using this scheme due to that the two OOK signals are injected into the SOA simultaneously, so there will be a crosstalk between the signals when it is used for signal multicasting. In order to receive constant power of the converted QPSK signal, the XPM process in SOA is properly controlled by an assistant light [18], consequently if multi-channel probe lights are injected into SOA for signal multicasting, the crosstalk between signals is still inevitable. Therefore, it is essential to develop OOK-to-QPSK format conversion scheme with multicasting function and low crosstalk, and this scheme will play a significant role in increasing the efficiency and scalability at the routing node of wavelength division multiplexing (WDM) network.

In this work, we use SOA based cascade structure to realize OOK to QPSK conversion. The scheme provides an all-optical format conversion, so it does not need expensive electronic equipment, and the processing speed can be faster than QPSK generated by electricity. On the other hand, compared with the SOA based MZI structure, our proposed work does not demand reserved bandwidth, nor does it require the phase-locking mechanism. In our experiment, two independent OOK signals with a bit rate of 10 Gbaud are successfully converted to a QPSK signal with wavelength multicasting. The proposed wavelength multicasting scheme owns low complexity and is easily compatible to WDM networks, furthermore, it maintains smooth performance with enormous low power penalty. Therefore it has the potential for wide applications in future photonic networks.

II. PRINCIPLE

Fig. 1 shows the schematic diagram of all-optical OOK to QPSK modulation format conversion. The phase of the CW probe light is first modulated via XPM induced by OOK1 in SOA1, and then modulated by OOK2 in SOA2. The peak power of OOK1 is adjusted in such a way that the probe light has a π phase shift when the data is “1”, and the output signal from SOA1 is the binary phase shift keying (BPSK) signal. Similarly, the peak power of OOK2 is adjusted to satisfy that

TABLE 1. Parameters of SOA.

Parameter	Value	Unit
Central wavelength	1550	nm
3dB Bandwidth	60	nm
Small signal gain	22	dB
Noise index	8.0	dB
Carrier lifetime	25	ps
Bias current	200	mV

the phase shift of probe light is $\pi/2$. After passing through the two SOAs, the OOK1 and OOK2 composed of {00, 01, 10, 11} can shift the additional phase of the probe light with {0, $\pi/2$, π , $3\pi/2$ } accordingly, so with different initial phase, different phase information of the converted signal can be achieved. Therefore, the probe light can maintain the phase information, thus generating a QPSK signal at the output of the scheme.

SOA is the key component used as a non-linear medium in the system, and the SOA (Model ISPAD1501, InPhenix) being used in the proposed scheme is a commercially available device. All parameters and values for the SOA are summarized in Table 1.

The phase shift of the probe light is mainly resulted by the control signal power. In order to optimize the performance of the converter, the phase shifts for the different probe signal powers of -7 dBm, -5 dBm and -3 dBm are measured, the results are shown in Fig. 2. For the same probe light power, the phase shift curves of different wavelengths i.e. 1552.4 nm, 1554.0 nm, 1555.6 nm and 1557.2 nm are almost coincident. When the probe signal power is -7 dBm, the phase shift is approximately 0.5π and π under the control signal power of -4 dBm and 2.3 dBm. If the probe light power is -5 dBm, the phase shifts of 0.5π and π can be obtained when the control optical power increases to -1 dBm and 5 dBm. When the probe light power increases to -3 dBm, phase shift of 0.5π can be received under the control signal power of 1 dBm, and until the control signal power reaches is 5 dBm, the phase shift does not exceed 0.8π .

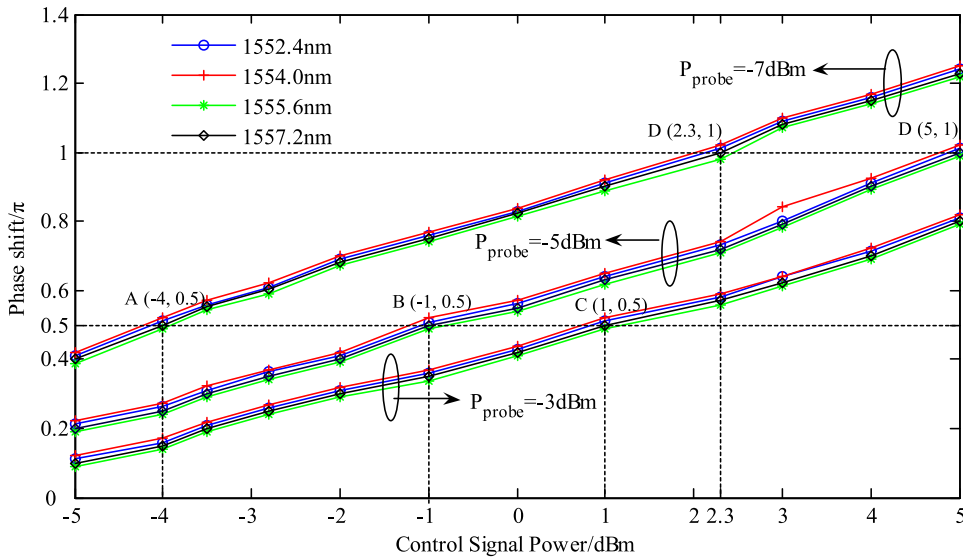

FIGURE 2. Phase shift characteristics as a function of control signal power.

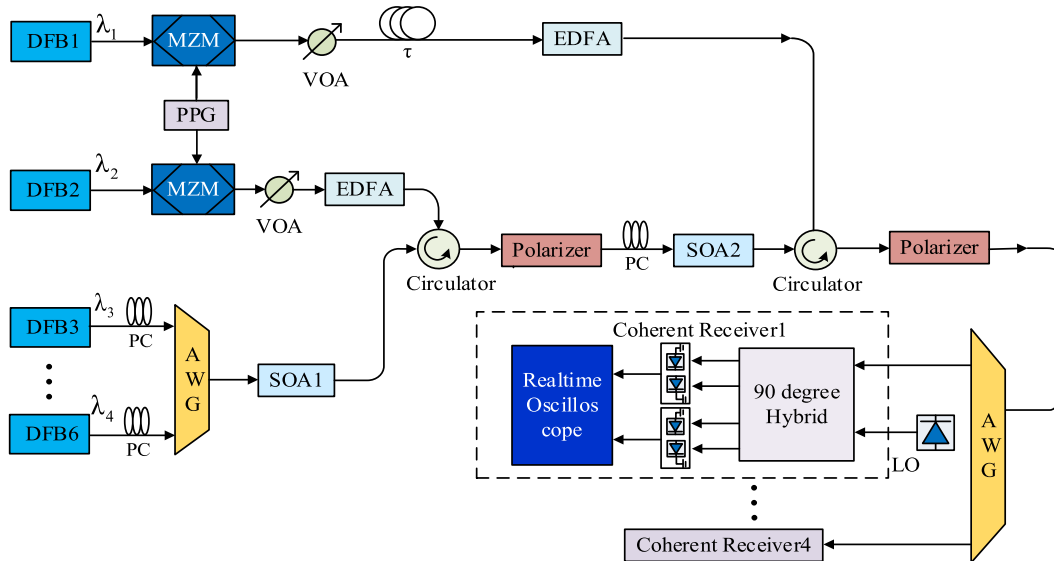

FIGURE 3. Structure of the format converter based on cascaded SOAs (DFB: Distributed Feedback Laser; MZM: Mach-Zehnder Modulator; EDFA: Erbium-doped fiber amplifier; AWG: arrayed waveguide grating).

III. EXPERIMENTAL SETUP AND RESULTS

Fig. 3 shows a schematic diagram of all-optical OOK to QPSK format conversion. The CW lights with wavelengths of λ_1 and λ_2 are modulated by Mach-Zehnder modulators (MZMs) to generate OOK1 and OOK2 signals. The MZMs are driven by an electrical signal, which is a pseudo random binary sequence (PRBS) from pulse pattern generator (PPG). The two OOK signals are amplified by erbium doped fiber amplifiers (EDFAs), where OOK1 is used as the control signal of SOA1 through a circulator, and OOK2 is used to control SOA2. A tunable optical delay line (ODL) is used to synchronize the signals temporally. Four probe lights with different wavelengths from λ_3 to λ_6 are passing

through the PCs and combined with an arrayed waveguide grating (AWG). After adjusting the polarization direction to align with the main axis of the SOA1, the probe lights are injected into the SOA1, and the OOK1 signal is used as control signal. We choose a counter-propagation scheme (the probe and pump lights counter-propagate in the SOA) due to that comparing with co-propagation, a counter-propagation scheme has the advantage of lower optical power requirements. The power of the control signal is set as follows: when the control signal changes between 0 and 1, the non-linear phase shift difference of the probe light is π . Then the probe light is converted to the phase modulated signal with two phases, 0 and π , consequently the BPSK converted

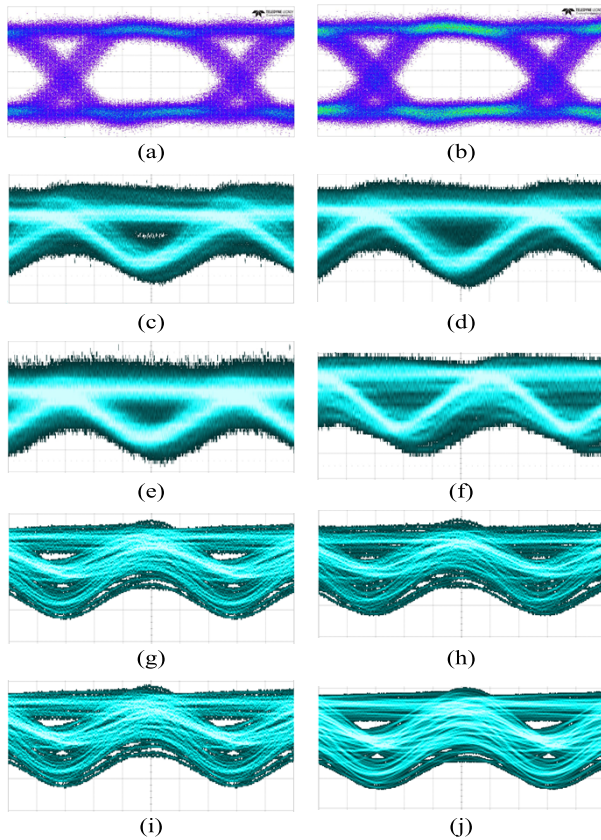

FIGURE 4. Eye diagrams of (a-b) input OOK signals, (c-f) converted 4-channel BPSK signals and (g-j) converted 4-channel QPSK signals.

signals are received. When the probe signals enter SOA2, with the control signal of OOK2, a $\pi/2$ phase difference is realized, thus leading to the probe lights with four phase information. Cross gain modulation (XGM) and nonlinear polarization rotation (NPR) effects are accompanied with XPM, and higher control optical power leads to smaller gain and larger rotation azimuth of the probe signal. Therefore by adjusting the polarization state of the input probe lights and polarizers behind the each SOA, the constant output power can be received.

In the receiver, four multicasting channels are separated by another AWG, and for the converted QPSK signal in each channel, coherent detection is used as shown in the lower dashed box of Fig. 3. The converted QPSK signal is mixed with a local oscillating signal in 90-degree hybrid to achieve coherent detection. The local oscillating signal is generated by a tunable laser with a linewidth of 100 kHz. The data signal is first processed by four balance photo detectors (PDs) whose bandwidth is 22 GHz, and then sampled and digitized by a four-channel digital storage 28 GHz sampling oscilloscope (OSC). Finally, the off-line digital signal processor (DSP) is used to process the captured data, and the constellation and BER are obtained. The DSP algorithms contain dispersion compensation, Gardner algorithm based clock recovery, constant modulus algorithm (CMA),

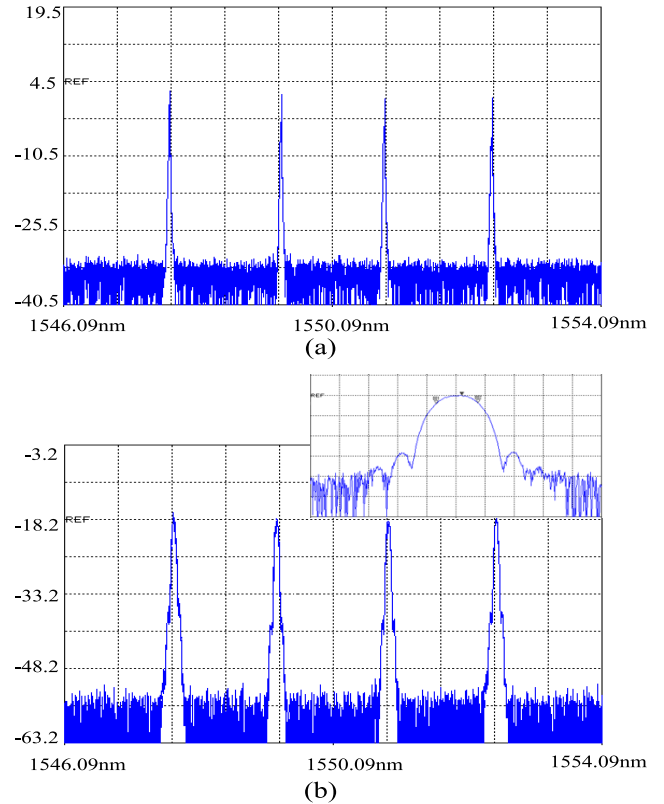

FIGURE 5. Measured spectra of (a) probe light and (b) converted signal.

frequency offset estimation and carrier phase recovery based on blind phase search (BPS) algorithm.

In our experiment, the wavelengths of the OOK1 and OOK2 signals are 1549.0 nm and 1550.0 nm, and the peak power of the OOK1 and OOK2 control signals is 2.3 and -4 dBm. The signal-to-noise ratio (SNR) of both OOK1 and OOK2 is 17 dB/0.1nm. The wavelengths of the input probe lights are ranging from 1552.4 nm to 1557.2 nm with interval of 1.6 nm, and the optical power of each channel probe light is -13 dBm, therefore, the total power of 4-channel probe lights is -7 dBm. The eye diagrams of the OOK1 and OOK2 signals are shown in Fig. 4(a-b), while the eye diagrams of the converted BPSK signal output from SOA1 are shown in Fig. 4(c-f), and characteristic binocular eyelids with QPSK signal can be seen in Fig. 4(g-j). The converter has the potential to deploy more wavelengths, with higher control signal power and lower probe light power. Because the power of each channel probe light is much lower than that of the control signal, the nonlinear effects mainly occur between the probe lights and the control signals. Then, even if the wavelength interval becomes smaller, the crosstalk between the probe signal channels is relatively weak. Due to the limitation of light source, four input probe signals is used in our experiment.

Fig. 5(a-b) shows the spectra of the four-channel input probe lights and the converted QPSK signals respectively. Due to the modulation by OOK control signals, the spectra

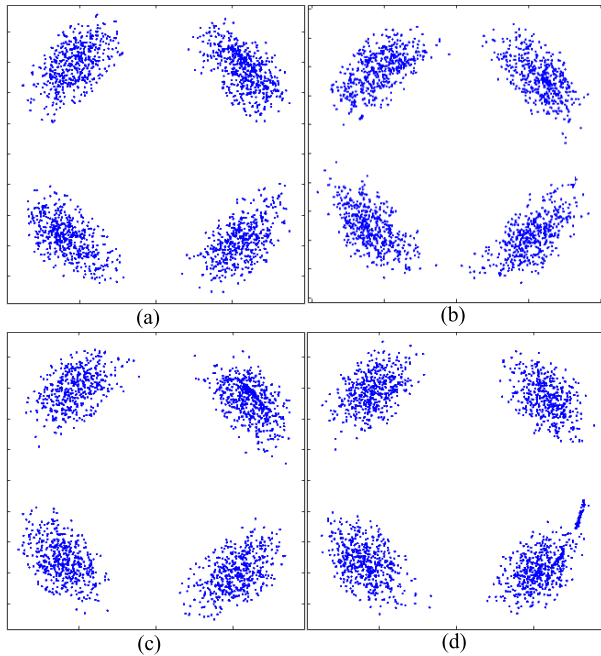

FIGURE 6. Constellation diagrams of the converted signals.

of all converted signals are broadened. The insert of Fig. 5 (b) shows the detailed spectrum of the one-channel converted signal. It can be observed that the main lobe of the spectrum has a unilateral bandwidth of 10 GHz, which is exactly half of the transmission bit rate.

The constellation diagrams of the converted signal after the off-line DSP process are demonstrated in Fig. 6, and the optical power of the acquired constellation diagrams is -10 dBm. The Error vector magnitude (EVM) of the converted signals is 13.27%, 13.83%, 13.32% and 14.14%, respectively. Different from a conventional QPSK that is generated from a nested IQ-MZM, the obtained QPSK does not have zero

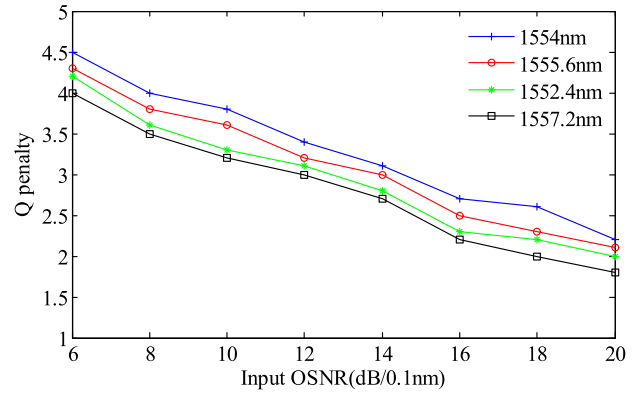

FIGURE 7. Q penalty for the converted signals against different OSNR of the input OOK signal.

crossings. The reason for this phenomenon is that the signal is obtained through XPM which will rotate the constellation points around the unit circle. Constellation diagrams of the converted signals also show high quality of format conversion with wavelength multicasting.

In order to quantify the properties of conversion, the Q penalty of the converted QPSK signals versus varying optical signal-to-noise ratio (OSNR) of the input OOK signal is measured. In the experiment, the modulated signal passes through a variable optical attenuator and then is coupled into an erbium doped fiber amplifier (EDFA) followed by a 4.5-nm optical band-pass filter, whose OSNR can be adjusted, and the OSNR of two OOK signals is adjusted to the same value. Figure 7 shows Q penalty as a function of the input OOK for different converted wavelengths. Here, Q penalty is defined as the Q value decline by the wavelength multicasting compared to the input Q value. As shown in Fig. 7, it can be seen that when the input OSNR of the OOK signal is low, the Q penalty is high, and with the increase of the OSNR, the Q penalty decreases. When the input OSNR is greater than

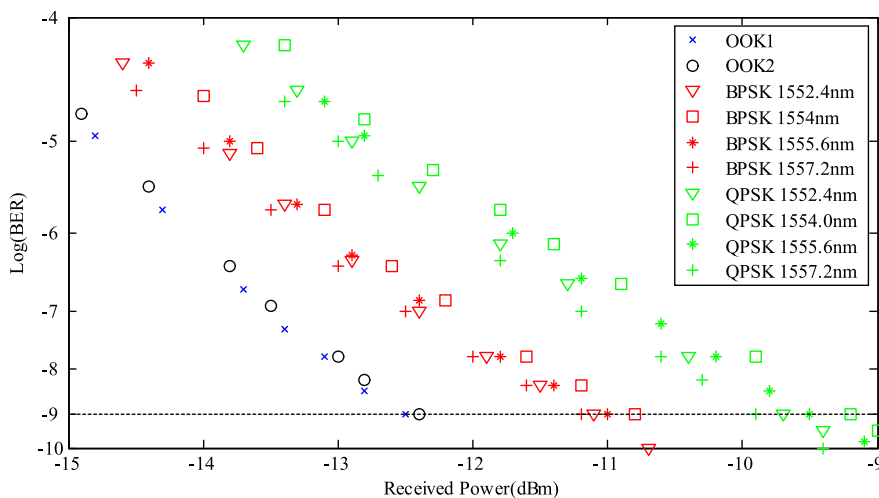

FIGURE 8. The measured Back-to-Back BER curves for 10 Gbaud OOK and converted QPSK signals.

12 dB/nm, the Q penalty is less than 3 dB. In addition, small variation in the Q penalty for different wavelengths is due to the frequency dependence (bandwidth limitation) of the SOA.

In order to further evaluate the quality of the converted signal, the BER of the four-channel multicasting signals are measured. Fig. 8 shows the measured back-to-back BER curves for 10 Gbaud OOK and converted QPSK signals. Thanks to our automated testing software, based on which the signal was collected for many times and measured them cumulatively, then 1×10^{10} data is used to calculate BER. Fig. 8 shows the BER of the converted signals with different wavelengths for the input signal OSNR of 17 dB/0.1nm. As shown in Fig. 8, at BER of 10^{-9} , the conversion signal of different wavelengths has a power penalty in the range 2.4 to 3.1 dB compared with the OOK1 signal and 2.7 to 3.4 dB compared with the OOK2 signal. The power penalties of the converted signal are resulted by the mismatch in optical timing among NRZ-OOK signals, the noises and the pattern effect from SOAs. In addition, the power penalty difference of 0.7 dB between the best and worst converted signals is resulted by the slight phase shift difference. When the wavelength of the probe light is 1557.2 nm, the phase shift of the probe light is closest to 0.5π and π with the control signal power of -4 and 2.3 dBm, so the converted signal has the least power penalty. And for the probe light with 1554 nm wavelength, the phase shift of the probe light is a little far from 0.5π and π , so there is more power penalty for the converted signal.

IV. CONCLUSION

A 10 Gbaud OOK-to-QPSK format conversion with four-channel multicasting scheme based on cascaded SOA configuration is experimentally demonstrated in this paper. The results show a constellation diagram with an EVM of 13.27%, 13.83%, 13.32% and 14.14% respectively, for each converted channel. For all cases of probe light wavelengths, the converted QPSK signals experience minor penalties ranging from 2.4 dB to 3.4 dB at BER of 10^{-9} compared with the input OOK signals. This modulation format conversion may become the key technology of all-optical network nodes in the future.

REFERENCES

- [1] Y. Li, M. Li, Y. Poo, J. Ding, M. Tang, and Y. Lu, "Performance analysis of OOK, BPSK, QPSK modulation schemes in uplink of ground-to-satellite laser communication system under atmospheric fluctuation," *Opt. Commun.*, vol. 317, pp. 57–61, Apr. 2014.
- [2] C. Behrens, D. Lavery, D. S. Millar, S. Makovejs, B. C. Thomsen, R. I. Killely, S. J. Savory, and P. Bayvel, "Ultra-long-haul transmission of 7×42.9 Gbit/s PS-QPSK and PDM-BPSK," *Opt. Express*, vol. 19, no. 26, p. B581, Dec. 2011.
- [3] R. Saunders, "Coherent DWDM technology for high speed optical communications," *Opt. Fiber Technol.*, vol. 17, no. 5, pp. 445–451, Oct. 2011.
- [4] F. Buchali, W. Idler, L. Schmalen, and K. Schuh, "Performance and advantages of 100 Gb/s QPSK/8QAM hybrid modulation formats," in *Proc. Opt. Fiber Commun. Conf.*, 2015, Art. no. Th2A-16.
- [5] C. Fürst, M. Camera, H. Wernz, and H. Griesser, "Experimental experiences in high speed DQPSK transmission," in *Proc. Opt. Fiber Commun. Conf. Nat. Fiber Optic Eng. Conf.*, 2009, Art. no. OMT5.

- [6] B. M. Cannon, T. Mahmood, W. Astar, P. Boudra, T. Mohsenin, and G. M. Carter, "Polarization-insensitive phase-transmultiplexing of CSRZ-OOK and RZ-BPSK to RZ-QPSK via XPM in a PCF," in *Proc. Opt. Fiber Commun. Conf.*, 2014, Art. no. W2A-52.
- [7] S. Searcy and S. Tibuleac, "Experimental study of cross-phase modulation reduction in hybrid systems with co-propagating 100G PM-QPSK and 10G OOK," *Opt. Express*, vol. 21, no. 25, pp. 31483–31491, Dec. 2013.
- [8] Y.-H. Wen and K.-M. Feng, "A simple NRZ-OOK to PDM RZ-QPSK optical modulation format conversion by bidirectional XPM," *IEEE Photon. Technol. Lett.*, vol. 27, no. 9, pp. 935–938, May 1, 2015.
- [9] K. Mishina, S. Kitagawa, and A. Maruta, "All-optical modulation format conversion from on-off-keying to multiple-level phase-shift-keying based on nonlinearity in optical fiber," *Opt. Express*, vol. 15, no. 13, pp. 8444–8453, 2007.
- [10] B. M. Cannon, T. Mahmood, W. Astar, P. Apiratikul, G. Porkolab, P. Boudra, T. Mohsenin, C. J. K. Richardson, and G. M. Carter, "All-optical amplitude-phase transmultiplexing of RZ-OOK and RZ-BPSK to RZ-QPSK by polarization-insensitive XPM using a nonlinear birefringent AlGaAs waveguide," *Opt. Express*, vol. 21, no. 17, pp. 19885–19899, Aug. 2013.
- [11] D. Wolfson, A. Kloch, T. Fjelde, C. Janz, B. Dagens, and M. Renaud, "40-Gb/s all-optical wavelength conversion, regeneration, and demultiplexing in an SOA-based all-active Mach-Zehnder interferometer," *IEEE Photon. Technol. Lett.*, vol. 12, no. 3, pp. 332–334, Mar. 2000.
- [12] B. Dai, S. Shimizu, X. Wang, and N. Wada, "All-optical modulation format conversion from NRZ-OOK to PSK-manchester using SOA-MZI," *Electron. Lett.*, vol. 48, no. 19, p. 1221, 2012.
- [13] M. Uetai, H. Kishikawa, and N. Goto, "Modulation format conversion from OOK and QPSK to 8QAM using XPM and XGM in an SOA," in *Proc. Conf. Lasers Electro-Opt. Pacific Rim (CLEO-PR)*, Jul. 2017, Art. no. s1582.
- [14] T. Amano, H. Kishikawa, and N. Goto, "Aggregation of OOK signal for modulation format conversion to 8QAM signal using XPM and XGM," in *Proc. Adv. Photon. Congr.*, 2019, Art. no. SpM2E-2.
- [15] F. Fresi, M. Scaffardi, N. Amaya, R. Nejabati, D. Simeonidou, and A. Bogoni, "40-Gb/s NRZ-to-RZ and OOK-to-BPSK format and wavelength conversion on a single SOA-MZI for gridless networking operations," *IEEE Photon. Technol. Lett.*, vol. 24, no. 4, pp. 279–281, Feb. 2012.
- [16] W. Astar and G. M. Carter, "10 Gbit/s RZ-OOK to BPSK format conversion by cross-phase modulation in single semiconductor optical amplifier," *Electron. Lett.*, vol. 42, no. 25, pp. 1472–1474, 2006.
- [17] Y. Z. Yueying Zhan, M. Z. Min Zhang, M. L. Mintao Liu, L. L. Lei Liu, and X. C. Xue Chen, "All-optical format conversion of NRZ-OOK to QPSK and 16QAM signals via XPM in a SOA-MZI," *Chin. Opt. Lett.*, vol. 11, no. 3, pp. 030604–30607, 2013.
- [18] Y. Gao, C. Shu, and S. He, "Cascaded SOA configuration for NRZ-OOK to RZ-QPSK format conversion," *Opt. Commun.*, vol. 283, no. 23, pp. 4609–4613, Dec. 2010.

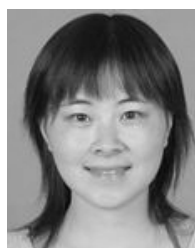

YAYA MAO received the bachelor's degree from Nanjing Normal University, in 2003, and the Ph.D. degree from Beijing Jiaotong University, in 2017. She is currently an Associate Professor with the Institute of Optoelectronics Research, Nanjing University of Information Science and Technology, China. Her current research interests include optical communication and all signal process.



BO LIU received the bachelor's, master's, and Ph.D. degrees in optical engineering from the Beijing University of Posts and Telecommunications (BUPT), in 2008 and 2013, respectively. He is currently a Professor with the School of Physics and Optoelectronics, Nanjing University of Information Science and Technology, China. His research interests include all optical signal processing, radio over fiber, and broadband optical communication.



JIANXIN REN received the B.S. degree in electronic science and technology from the Beijing University of Chemical Technology, Beijing, China, in 2016. He is currently pursuing the Ph.D. degree in optical engineering with the State Key Laboratory of Information Photonics and Optical Communications, Beijing University of Posts and Telecommunications, China. His research interests include optical communication, passive optical networks, and optoelectronics.



XIANGYU WU received the B.S. degree in electronic engineering from the Beijing University of Posts and Telecommunications, China, in 2015, where he is currently pursuing the Ph.D. degree in electronic science and technology with the State Key Laboratory of Information Photonics and Optical Communications. His research interests include optical communication systems, optical interconnects, and integration network technology.



XING XU received the B.S. degree from the Beijing University of Posts and Telecommunications, China, in 2015, where he is currently pursuing the Ph.D. degree in electrical science and technology. His research interests include optical access networks and SDN architecture.



LEI JIANG received the bachelor's degree in applied physics from the Nanjing University of Information Science and Technology (NUIST), China, in 2017, where she is currently pursuing the master's degree with the School of Physics and Optoelectronics. Her research interests include optical communication, passive optical networks, and optical signal processing.

...