

Received January 27, 2020, accepted February 12, 2020, date of publication February 17, 2020, date of current version February 27, 2020.

Digital Object Identifier 10.1109/ACCESS.2020.2974571

Evaluation of DC Power Quality Based on Empirical Mode Decomposition and One-Dimensional Convolutional Neural Network

HUIXIN LI¹, BENSHUN YI¹, QINGXIAN LI², JUN MING¹, AND ZHIGANG ZHAO³

¹School of Electronic Information, Wuhan University, Wuhan 430072, China

²Hunan Institute of Metrology and Test, Changsha 410014, China

³Gree Electric Appliances, Inc., Zhuhai 519070, China

Corresponding author: Benshun Yi (yibs@whu.edu.cn)

This work was supported by the National Key Research and Development Program of China under Grant 2018YFF0212900.

ABSTRACT With the rise in the use of DC distributed energy resources and the growth of DC electricity load, the difficulty in improving DC power quality has become an important research direction. The research on DC power quality has an important impact on the development of DC power distribution theory and technology. In this paper, an evaluation method that combines empirical mode decomposition (EMD) with a one-dimensional convolutional neural network (1D-CNN) of DC power quality is proposed. As a method of data preprocessing, EMD decomposes the original electrical signal into several intrinsic mode functions (IMFs). Then, the 1-D CNN with a residual module is used to train the data obtained from EMD and conducts a comprehensive evaluation with different levels. In addition, the proposed network was compared with other state-of-the-art deep neural networks, and the experiment proved its effectiveness. Finally, an example analysis is carried out with the data provided by the Gree Photovoltaic Direct-driven Inverter Multi VRF (variable refrigerant flow) System to show the validity of the proposed method for evaluating DC power quality in a real case.

INDEX TERMS DC power quality, photovoltaic direct-driven inverter multi VRF, empirical mode decomposition, one-dimensional convolutional neural network.

I. INTRODUCTION

Currently, to deal with the world energy crisis and achieve low-carbon development, many countries are actively committed to using renewable energy sources to replace non-renewable energy sources for power generation. Due to the special geographical distribution of renewable energy, the electricity generated by large-scale renewable energy resources such as solar energy, fuel cells, and wind energy needs to be transmitted over long distances [1]. Studies have shown that the high voltage direct current (HVDC) is the preferred solution for the long-distance transportation of electrical energy generated by clean energy sources. DC power distribution systems have many advantages over AC power distribution systems. For example, they offer higher efficiency and reliability with improved power quality; they reduce installation costs because they require fewer power

conversion stages, fewer copper wires and smaller floor space; DC power distribution can simplify the integration of renewable energy and energy storage systems; since the power supply is distributed by DC, there is no reactive power or skin effect in the system; unlike AC power distribution systems, the DC power distribution system does not require any synchronization, so it facilitates plug and play features [2]. The DC transmission grid is a major technological advancement in point-to-point HVDC connection technology and is being considered by many applications around the world [3]. High voltage direct current (HVDC) power grids are considered to be an effective solution to the current situation of heavy use of renewable energy and AC grid congestion [4]. Therefore, the use of direct current transmission to transport renewable electricity will become increasingly popular.

In recent years, the power quality of both AC and DC systems has received widespread attention due to the widespread use of electronic devices and other asymmetric loads [5]. It is obvious that power quality is an important characteristic

The associate editor coordinating the review of this manuscript and approving it for publication was Padmanabh Thakur.

of today's distribution power systems since loads become more sensitive, and nonlinear loads are increasing in the electrical distribution system [6]. However, with the large-scale construction of power grids, power quality problems have become increasingly prominent, which not only affects the safe operation of electrical equipment but also may cause economic losses. Therefore, improving power quality is of great significance. To improve power quality, the first problem is how to effectively evaluate the power quality. The International Electrotechnical Commission (IEC) has issued some basic regulations about power quality testing and evaluation, such as the IEC 61000 series standards [7]. IEEE has also issued various standards related to power quality, such as IEEE 519, 1159, 1459 [8], [9]. Unfortunately, the above standards are all about AC power quality.

There are many methods for power quality evaluation of AC systems. First, some traditional methods are used in evaluating AC power quality, such as the analytic hierarchy process (AHP) [10], empirical wavelet transform (EWT) and rational dilation wavelet transform (RADWT) [11], S-transform [12], and empirical mode decomposition (EMD) [13]. There are some advantages and disadvantages of each technique. Specifically, EMD is widely used in the evaluation of AC power quality but can only decompose the original data and extract features. The combination of other methods, such as the neuro-fuzzy system (NFS) classifier [14] and support vector machine (SVM) [15], can achieve the goal of power quality classification.

Classification networks have been widely applied to evaluate AC power quality, including multifusion convolutional neural networks (MFCNNs) [16], convolutional neural networks (CNNs) [17], and pulse coupled neural networks (PCNNs) [18]. In addition, some combinations of traditional methods and classification networks have been tried. Mrutyunjaya et al. detected and classified power quality events by integrating the Hilbert-Huang transform (HHT) and weighted bidirectional extreme learning machine (WBELM) [19]. A novel classification method for power quality events using wavelet packet transform (WPT) and extreme learning machines (ELMs) has been proposed in the literature [20].

All the above methods are for AC and are not suitable for DC. Compared with AC power, there are no indexes of frequency, phase and reactive power for the evaluation of DC power quality [21]–[23]. Affected by the zero-frequency characteristic of the DC voltage and the structure of the DC transmission grid, the correlation between the various DC power quality indicators is significantly enhanced compared to that of the AC indicators [24]. The forms of DC generation are various, such as wind energy and solar energy, which fluctuate by the environment [25], [26]. In addition, DC microgrids have advantages over conventional AC microgrids, such as being free from reactive power and total harmonic distortion [27]. Connecting DC load directly to the photovoltaic system may gain better efficiency because the power supplied to the load is transferred through fewer subsystems and

conversion [28]. Considering that the large-scale transportation of clean energy is mostly based on DC transmission and that DC power distribution is more efficient than AC power distribution, research on DC power quality has become increasingly important [29], [30].

There are only a few articles on the evaluation of DC power quality. Ciornei et al. proposed that a set of time and frequency domain indicators for quantifying power quality problems may occur in DC microgrids [31]. A combination weighting method based on maximizing deviation to integrate subjective and objective weight coefficients was presented in paper [32]. The literature [22] preliminarily discusses the disturbances specific to DC networks, proposes some indexes for their characterization and defines indexes for DC power quality assessment. A fault location method for high voltage DC transmission lines using the Hilbert-Huang transform and 1-D CNN was proposed in the literature [33].

Although there have been some evaluation methods for power quality, as mentioned above, the research on power quality evaluation is still not comprehensive enough. Most of the existing methods are for AC rather than DC [34], and there is still a lack of effective methods for DC power quality evaluation. Additionally, most of the methods are based on predefined power quality indexes rather than the original electrical signal, so the accuracy of evaluation results depends heavily on the selection of the predefined indexes [35], which is not beneficial for the comprehensive evaluation of power quality. In particular, there is no well-defined standard for DC power quality among scholars and utilities. In addition, most of the relevant studies were based on the data produced by simulation rather than collected from real applications in a microgrid [19].

In this paper, a DC power quality evaluation method that combines EMD and 1D-CNN is proposed to solve these issues. The input is the original electrical signal, and the output is the corresponding evaluation result. Since this framework is end-to-end, there is no need to use predefined indexes in the evaluation process. The mapping from the original electrical signal to the evaluation result is automatically learned by the proposed framework. Then, an example analysis is carried out with the real data provided by the Gree company photovoltaic cottage to show the validity of the proposed method for evaluating DC power quality. To verify the effectiveness of the proposed model, a comprehensive comparison of accuracy and training time with other advanced deep neural networks (DNNs) is conducted, including long short-term memory (LSTM), a gated recurrent unit (GRU), and residual networks-50 (ResNet50). Compared to these three networks, the network proposed in this paper is better, greatly reducing the number of parameters. The experimental results show that the proposed method has good performance in both accuracy and time cost.

II. METHODOLOGIES

This section provides an overview of the related algorithms used for DC power quality evaluation in the proposed method.

The principle and realization of the theories are illustrated in detail.

A. DECOMPOSITION ALGORITHM—EMPIRICAL MODE DECOMPOSITION

EMD is an adaptive signal decomposition algorithm proposed by Huang et al. in 1998 [36]. Unlike traditional signal analysis methods such as wavelet transform and short-time Fourier transform, EMD is a fully data-driven and adaptive method that is very suitable for processing nonlinear and nonstationary signals. The DC data analyzed in this paper have many fluctuations, which can be decomposed by EMD.

Considering that the distorted waveform of a transient signal with DC bias in the field of power transmission can be conceived as a superposition of various oscillating modes, we use EMD to separate these IMFs from the original signal, and these IMFs must satisfy two conditions. One is that the number of zero crossings and the number of extrema must either be equal or differ by no more than one, and another is that the mean value of the envelope defined by the local maxima and the envelope defined by local minima must be zero. The details of the EMD algorithm are as follows:

1. Find the location of the local maxima and minima points of the signal $x(n)$.
2. Interpolate the local maxima using the cubic spline line to obtain the maxima envelope $e_{max}(n)$, then repeat the same procedure for local minima to obtain the minima resenvelope $e_{min}(n)$.
3. Calculate the mean of the maxima envelope and minima envelope: $e_{mean}(n) = (e_{max}(n) + e_{min}(n)) / 2$.
4. Calculate the difference between the signal and the mean of envelopes: $h(n) = x(n) - e_{mean}(n)$.

5. Examine whether $h(n)$ satisfies the two conditions of IMF. If satisfied, select $h(n)$ as the IMF; otherwise, take $h(n)$ as the input signal and repeat step 1-step 4 until the new IMF is obtained.

6. Determine the residue: $r(n) = x(n) - h(n)$.

7. The signal decomposition is terminated when $r(n)$ is a monotonic function or the stop condition of the algorithm is reached; otherwise, repeat steps 1-6 and take $r(n)$ as the input signal.

After applying the EMD algorithm, the original signal can be represented by all the IMFs and the residue as $x(n) = \sum_{i=1}^K h_i(n) + r_K(n)$.

To verify the decomposition results of EMD, a synthetic signal containing a constant is established in MATLAB, which is given by equation (1):

$$f = 1 + 0.5 \cos(2\pi \times 50t) + 0.25 \cos(2\pi \times 100t) + 0.1 \times n(t) \quad (1)$$

Except for the constant component with an amplitude of 1, the synthetic signal is composed of two harmonic components and white noise $n(t)$, and the waveform is sampled at 1,000 Hz. The principle of EMD has its basis derived from the Hilbert-Huang transform (HHT), which requires neither any convolution of the signal nor any a priori basis functions. The only parameter needs to be determined is K, which is the number of IMFs. According to the literature [19], we choose $K = 3$, and the result is shown in Fig. 1.

In Fig. 1, the first row is the original signal and its spectrum. We determine that the frequencies are 0, 50 Hz, and 100 Hz, and the corresponding amplitudes are 1 V, 0.5V, and 0.25V. The second to fourth rows are IMF1, IMF2, and IMF3,

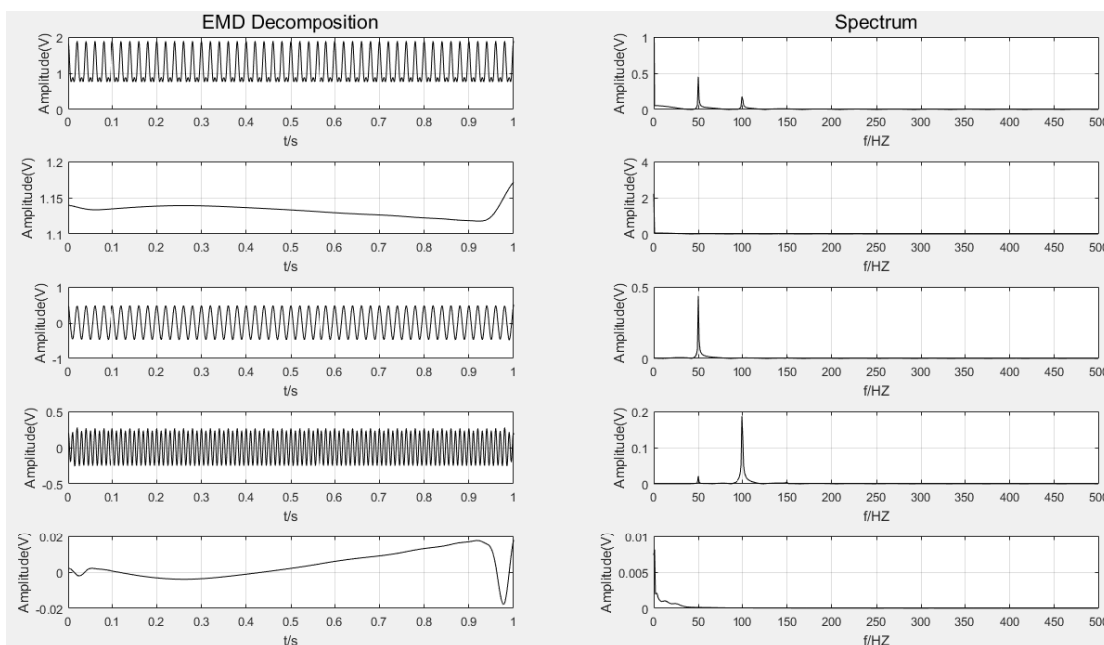

FIGURE 1. The decomposition result of EMD.

and the last row is the residual component. The decomposed modes and their frequency spectra are illustrated in Table 1.

TABLE 1. Decomposition results of EMD harmonics extraction.

Synthetic Signal		Results of EMD	
Freq. (Hz)	Amp. (V)	Freq. (Hz)	Amp. (V)
0	1	0	1.12
50	0.5	52	0.437
100	0.25	103	0.187

B. CLASSIFICATION METHOD BASED ON DEEP CNN

CNN is a powerful deep neural network inspired by visual neuroscience, which was first applied to the field of computer vision and has already produced extremely impressive progress. In this section, the advantages and applicability of applying a deep CNN named RES-CNN to DC power quality evaluation are introduced.

1) THE PROPOSED FRAMEWORK BASED ON DEEP CNN

Compared with the neural network without convolutional layers, CNN boosts performance through several key mechanisms, such as local connections, shared weights and pooling operations [37]. With a 2-D input image, CNN can effectively extract the features of high-level abstraction through multiple convolutional layers, which can then be fed into a fully connected neural network for classification purposes. The weights inside the CNN are automatically learned during the training procedure, so the CNN has good adaptability and requires very little manual operation.

Power quality evaluation can also be regarded as a classification problem, i.e., the power quality abstracted from electrical signals can be divided into different levels from good to bad. Considering that the electrical signals are one-dimensional, we apply 1D-CNN to classify different power quality levels. The basis of the 1D-CNN architecture is similar to that of conventional CNN, so the underlying patterns of input signals can still be effectively learned by performing convolution and pooling operations similar to conventional CNN. The difference is that the use of 1-D input data requires the application of 1-D filters on the convolutional layers.

As shown in Fig. 2, this paper introduces a classification framework based on deep CNN, which demonstrates the overall framework and consists of EMD and 1D-CNN. As seen in Fig. 2, the original electrical signal is first pre-processed by EMD to obtain several IMFs, and then these IMFs are put into 1D-CNN to obtain the final evaluation result.

Before using EMD to decompose data, some measurements of data processing are made. First, three indexes of voltage interruption, voltage sag and voltage deviation are calculated for each group of data. According to IEC 61000-4-29 [38], voltage interruption describes the disappearance of the supply voltage at a point of the voltage DC distributed

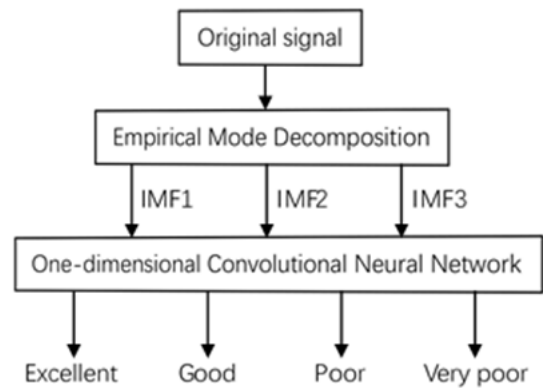

FIGURE 2. The overall framework proposed in this paper.

system for a period of time, typically not exceeding 1 minute. Voltage sag refers to a sudden reduction in the voltage at a point in the DC distribution system, followed by voltage recovery after a short period of time, from a few milliseconds up to a few seconds. According to IEC TS 62749 [39], the voltage deviation describes the difference between the supply voltage and nominal voltage. Another two indexes of voltage ripple and current ripple can be obtained from the power analyzer. According to IEEE Std 1515 [40], voltage ripple is the maximum AC voltage present on a DC or low-frequency AC voltage stated in peak-to-peak voltage. The current ripple is the maximum AC current component present on a DC or much lower frequency current stated in the peak-to-peak current.

Then, these metrics of DC data are labeled into different levels based on the comprehensive label method combined with the AHP and entropy coefficient method [11], [41], and the labels obtained are excellent, good, poor, and very poor. Four typical labels of the group of data are given in Table 2. If the label is represented as {1, 0, 0, 0}, it means that this sample belongs to the first category, which means excellent.

TABLE 2. Typical indexes of data samples for labeling.

Cases to be labeled	Case 1	Case 2	Case 3	Case 4
Voltage interruption (%)	1.08	2.95	3.52	4.16
Voltage sag (%)	0.35	1.68	1.75	5.26
Voltage deviation (%)	1.08	1.95	2.13	2.91
Voltage ripple (%)	0.26	1.59	2.45	3.53
Current ripple (%)	0.37	1.65	2.59	4.25
Label	Excellent	Good	Poor	Very poor

After labeling, EMD decomposes these data with labels into several IMFs, and these IMFs are input into a 1-D CNN. After the training process of the 1-D CNN, we classify every group of data into different levels from excellent to very poor.

As an electrical signal can be decomposed into different numbers of IMFs, the problem focuses on how to choose

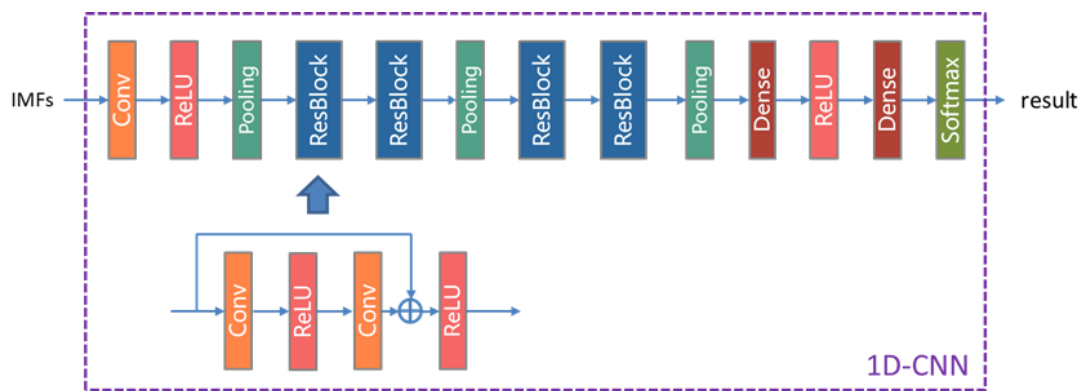

FIGURE 3. The structure of the proposed network.

suitable number of IMFs from a signal. To address this problem, we adopt a simple approach that extracts the first three IMFs for each input signal. The reason for choosing the first three IMFs comes from the experience that power quality events are most correlated with the first three modes of oscillation [19]. If the electrical signal has only one or two IMFs, the remaining IMFs are assigned to zero.

2) UNIT CONSTRUCTION OF THE CNN NETWORK

After the IMFs have been extracted, they are fed into the 1D-CNN, and the architecture of the 1-D CNN proposed in this paper is shown in Fig. 3. It is composed of pooling layers, dense layers, rectified linear units and ResBlock.

The ResBlock is used to extract features that consists of 1-D convolutional layers and an activation function, and it has a skip connection in addition to the convolutional layer and the activation function. This strategy is also well known as residual learning, which improves training efficiency since it is easier to optimize the residual mapping than to optimize the original unreferenced mapping [42]. Although residual learning has been widely used in 2D-CNN, few people have introduced it into 1D-CNN. We adopt residual learning in our proposed 1D-CNN and find that residual learning plays a positive role in improving the classification accuracy of the network.

3) DESCRIPTION OF THE LAYERS IN RES-CNN

In the deep CNN proposed in this paper, there are different layers, and they are briefly introduced in the following paragraphs.

1. 1-D convolutional layer: This layer is responsible for extracting features, and we compute the dot product between an area of the input data and a weighting matrix (filter). The filter slides over the whole data and repeats the same dot product calculation. ReLU is the most widely used activation function in CNN, which adds the ability of nonlinear mapping to the network.

2. Pooling layer: The pooling layer is used to downsample the signals, which can reduce the quantity of data to be

processed in the next layer, and it can effectively suppress overfitting while reducing the computational cost of the network. The two most common pooling methods are average pooling and maximum pooling, which aim to obtain the average value or to find the maximum value from the elements covered by the convolution kernel, and we choose the latter in this paper.

3. Dense layer: In the fully connected layer, each neuron is connected to all neurons in its previous layer, and it maps the learned feature representation to the label space. This layer can integrate local information with category discrimination in the convolution layer or pooling layer.

4. Softmax layer: This layer is a fully connected layer. Its function is to map the output of CNN to (0,1) and gives the probability of each classification. It requires that the number of neurons is equal to the number of categories and then gives the result of classification.

4) COMPARISON WITH STATE-OF-THE-ART DNNs

Three advanced DNNs are employed to compare performance with the method proposed in this paper. They are briefly introduced in the following paragraphs, and these DNNs are shown in Table 3.

TABLE 3. DNNs for comparison in the evaluation of DC power quality.

Network name	Number of layers	Type
LSTM	LSTM layer: 3, activation: tanh Dense layer: 1, activation: softmax	RNN
GRU	GRU layer: 3, activation: tanh Dense layer: 1, activation: softmax	RNN
ResNet50	Conventional 2-D layer: 49, activation: ReLU Dense layer: 1, activation: softmax	CNN
Res-CNN	Conventional 1-D layer: 9, activation: ReLU Dense layer: 2, activation: softmax	CNN

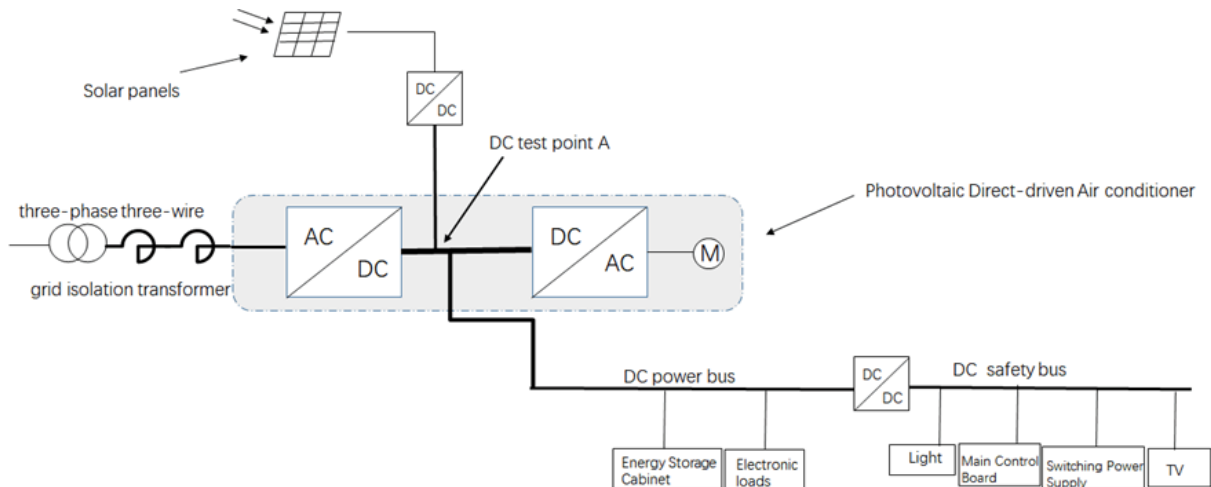

FIGURE 4. The structure of the DC microgrid in Gree's photovoltaic cottage.

1. LSTM: LSTM has achieved great performance in work about power quality [43], [44]. This is a typical recurrent neural network (RNN) with a memory unit consisting of a gated input, a gated output, and a gated feedback loop [45]. In this paper, an improved LSTM with 3 LSTM layers and 1 dense layer is applied for comparison [35].

2. GRU: GRU is another type of RNN that eliminates a separate storage unit [46]. There is no conclusive result in comparing performance between LSTM and GRU, and the performances of the LSTM and GRU depend on the task and dataset [47]. In this paper, a GRU network with 3 GRU layers and 1 dense layer is adopted for comparison [35].

3. Resnet-50: Residual networks allow the training of networks up to more than 1,000 layers using a structure called block, and ResNets are widely used in the classification of images [48]. In this paper, ResNet-50, which is a deep network with 50 layers, is applied to the classification of power quality for comparison to the proposed network. ResNets were originally designed for image classification. For the requirements of power quality evaluation, the dimension of the input signal is changed from $(800 + 41)$, the insufficient number is added to zero) to (29×29) , and a softmax layer with 4 neurons replaces the output layer.

III. EXPERIMENTS AND RESULTS

In this section, a series of experiments in different aspects are designed to verify the effectiveness of the evaluation of DC power quality by using the proposed Res-CNN. The first experiment was intended to assess the validity of Res-CNN with ResBlock and the decomposition of EMD. The second experiment was performed to compare Res-CNN with LSTM, GRU and ResNet50 and to analyze the characteristics of each network.

A. EXPERIMENTAL SETUP AND DATA COLLECTION

We conducted research by using the DC power data provided by the photovoltaic cottage project of Gree Company in

Zhuhai, China. Gree's photovoltaic cottage is a DC microgrid system that has the advantages of clean power generation, safe power storage, reliable power conversion and efficient power consumption. Fig. 4 shows the structure of the DC microgrid in the photovoltaic cottage. We simulated real power consumption by mounting various electronic loads connected to the DC bus with DC test point A, such as an energy storage cabinet, an adjustable electronic load and the photovoltaic direct-drive inverter and an air conditioning system as a load, and then collected data from the DC test point at a sampling frequency of 2.56 kHz. If there is residual power after meeting the consumption demand of electrical loads, the DC system can deliver the residual power to the AC grid in real time to realize the complete utilization of photovoltaic power. The top view of Gree's photovoltaic cottage is shown in Fig. 5.



FIGURE 5. Top view of Gree's photovoltaic cottage.

The green photovoltaic direct-drive inverter multi-VRF system exceeds the traditional air conditioning system, seamlessly combining photovoltaic power generation with the power consumption of the air conditioner. In the experimental setup, the input power of the photovoltaic direct-drive system is approximately 20 kW, and the output voltage in the DC bus is approximately 620 V~670 V.

An electronic load is a test instrument designed to sink current and absorb power out of a power source. In this experiment, the electronic load is in constant current mode, and there are two working states of operation. The first state is the pulse state, and the current value jumps between 1A and 6A with a period of 2 ms. The second state is a continuous state, and its current is approximately 5A with little fluctuation.

The energy storage cabinet manufactured by Gree company is used as an electric energy load in the experiment. The rated capacity of this energy storage cabinet is 1.6 MWh, and its charge-discharge conversion efficiency is greater than 97% when the equipment is in normal operation. In this experiment, the rated input voltage of the energy storage cabinet is 620 V with a charging current of 4A.

This experiment uses a power analyzer to collect real data. The resolution of the power analyzer is 18 bits with 0.01% accuracy. The sampling data of real current, voltage and some indexes, such as voltage ripple and current ripple acquired from the power analyzer, are transferred to a computer through a gigabit Ethernet interface.

The real data is decomposed by EMD, and we obtain the six IMFs. Among them, three IMFs are the decomposition results of DC voltage, and another three IMFs are of DC current. In the DC bus of test point A, the range of DC voltage is 620~670 V, and the range of DC current is 10~20 A. To obtain better training performances, the ranges of the IMFs are narrowed to 0~3 before inputting the IMFs into the networks.

The implementation details of the 1D-CNN are as follows: for each convolutional layer, the size of the convolution kernel is set to 16, and the number of feature maps is set to 64. The first fully connected layer contains 100 neurons, and the second layer contains 4 neurons because the power quality is divided into 4 different levels in our simulation. We set the batch size to 256, and the network is trained for 60 epochs. Categorical cross-entropy is used as the loss function, and it is optimized by the Adam algorithm [49].

After data acquisition, we first crop the original signal into fragments, each fragment contains 800 sampling points, and there is a partial overlap between adjacent fragments. Then, these fragments are labeled as one of four different power quality levels, and the number of each level from excellent to very poor was 19891, 13514, 12622, and 12355. In addition, 80% of them are chosen as the training set, 10% as the validation set and 10% as the test set.

B. COMPARISON BETWEEN EMD AND VMD

Variable mode decomposition (VMD) is a completely nonrecursive modal variational method [50]–[52] that uses multiple Wiener filtering groups to realize filtering. The VMD algorithm includes two parts: the construction of the variational problem and the solution of the variational problem.

To compare the performances between 1-D CNN with EMD and VMD, the parameters of VMD maintain the same decomposition level as EMD. VMD is a parametric method that requires careful parameter settings for use.

The performance is greatly influenced by their parameter settings, but the settings are always empirical with the lack of theoretical guidance. According to the literature [53], a group of balancing parameters of VMD, such as the data-fidelity constraint, the time step of the dual ascent, and the tolerance of convergence criterion, are set as 2000, 0 and 10^{-7} , respectively.

The comparison results of 1-D CNN with EMD and VMD is shown in Fig. 6, and we know that EMD performs better than VMD with the proposed 1-D CNN. Compared with the net with VMD, the net with EMD can achieve higher accuracy and lower loss. In addition, the training times of the signal decomposed by VMD and EMD are 1053.50 s and 839.27 s, respectively. We know that the training process for VMD requires more time than EMD. Therefore, EMD is more suitable for the proposed 1-D CNN than VMD.

C. PERFORMANCE ANALYSIS FOR ADDING RESBLOCK AND EMD

First, this section compares the training effect of RES-CNN and the network without the residual module, which is called plain CNN. Second, we put the original data into the RES-CNN network directly without the EMD process and then compare the training result with the EMD process. The experiments are performed using an Intel Core i7-6850K CPU with 64 GB of main memory and a Nvidia GeForce GTX 1080 Ti GPU with a graphics memory of 11 GB. The accuracy and loss value are obtained on the validation and training set for each epoch, and the training results of the experiments under different conditions are shown in Fig. 7.

Fig. 7 shows that the RES-CNN performs much better than the plain CNN. We can see that the network accuracy of training is approximately 83% after the residual module is removed, but the best training accuracy of Res-CNN reached 98%. Fig. 7 also presents a comparative experiment on the effect of EMD on network accuracy. If we put the original data into RES-CNN without the decomposition of EMD, it performs poorly; the best accuracy of the training set is only 72%, and the best loss value is 56%. The above experiments confirm that the introduction of residual learning into our proposed RES-CNN and the data preprocessing by EMD play a positive role in improving the accuracy of the network.

D. COMPARATIVE ANALYSIS WITH OTHER DNNs

In practice, the training process based on backpropagation is computed over every epoch. The accuracy and loss value during the training process are shown in Fig. 8, which shows the curve of the training accuracy with the number of epochs. Among these four DNNs, the best performance is provided by Res-CNN. Although ResNet50 has a deeper hierarchy than Res-CNN, it does not perform better than Res-CNN, as we expected. Res-CNN has better generalization capability than ResNet50. This demonstrates that a deeper network is not necessary and that the deep CNN with ResBlock is efficient enough to capture the detailed characteristics of each level.

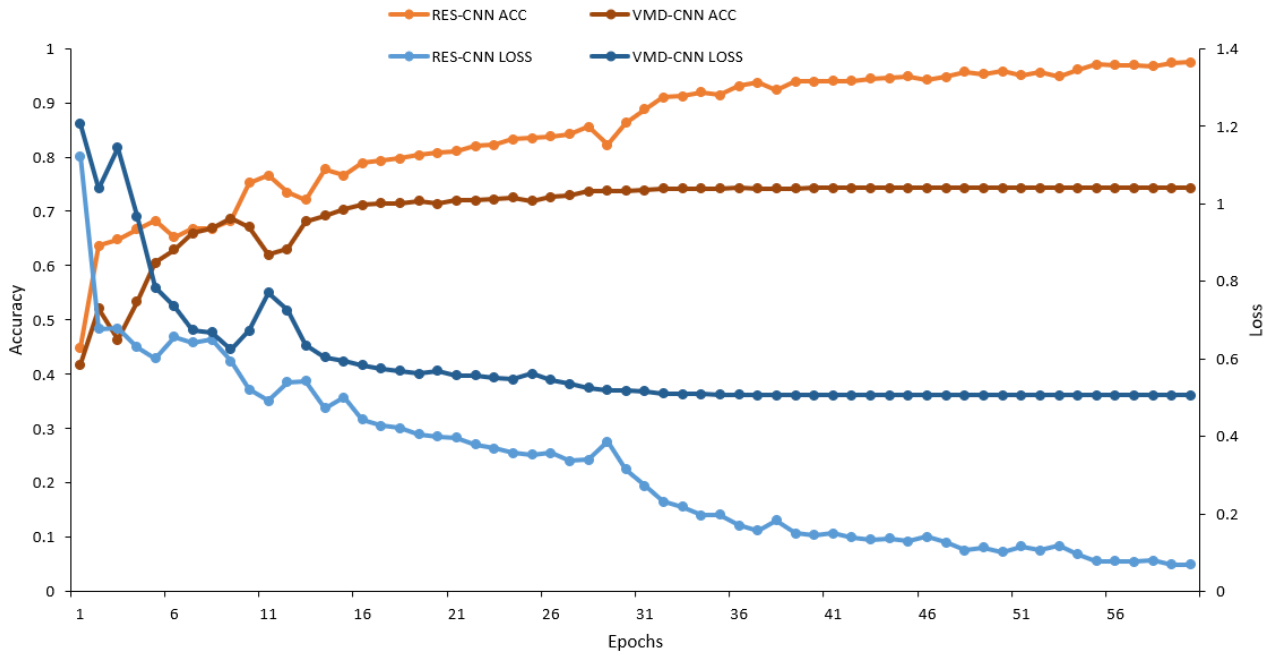

FIGURE 6. The comparison results of the 1D-CNN with EMD and VMD.

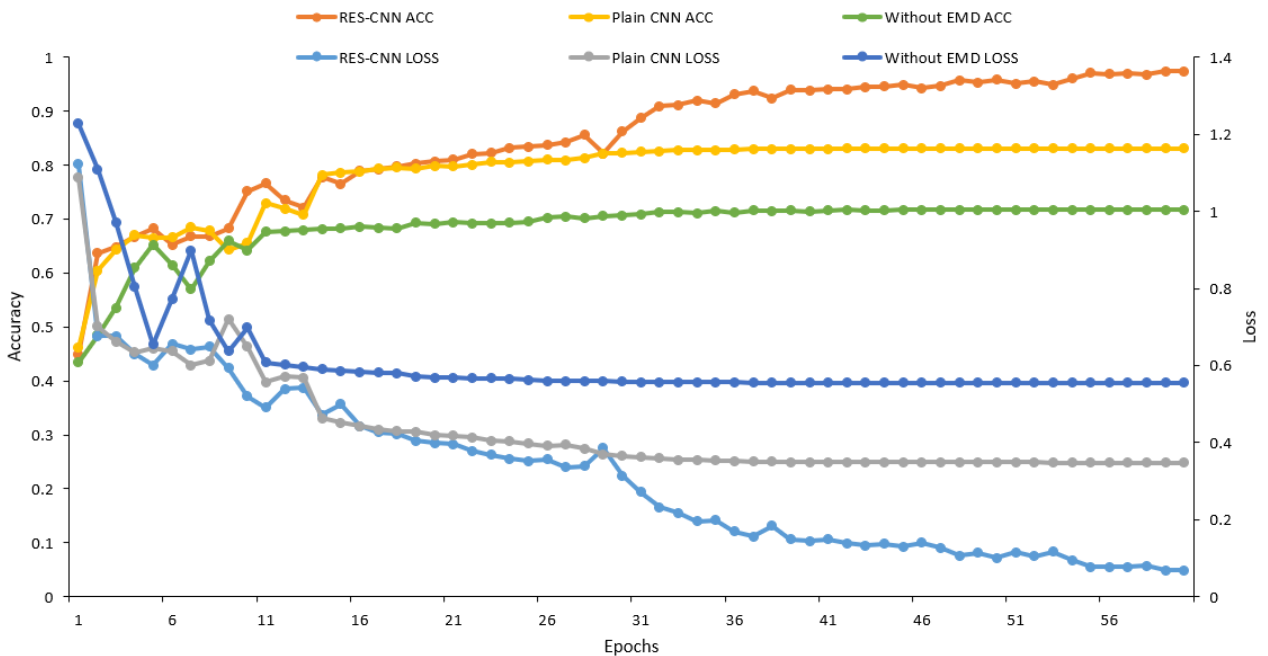

FIGURE 7. The comparison results with and without residual module and EMD.

The performances of LSTM and GRU are similar. However, for signals with violent fluctuations, the accuracies of LSTM and GRU are lower than that of Res-CNN. It can be seen that the accuracy of Res-CNN is very close to the maximum at the 39th epoch and then oscillates slightly near the maximum.

The testing set with 5,838 samples is put into Res-CNN, and the result of the confusion matrix is shown in Table 4. The recall values of the level from excellent to very poor are 99%, 92%, 79%, and 77%, and their precision values are 96%, 97%, 76%, and 79%. This shows that the evaluation result is very reasonable and convincing.

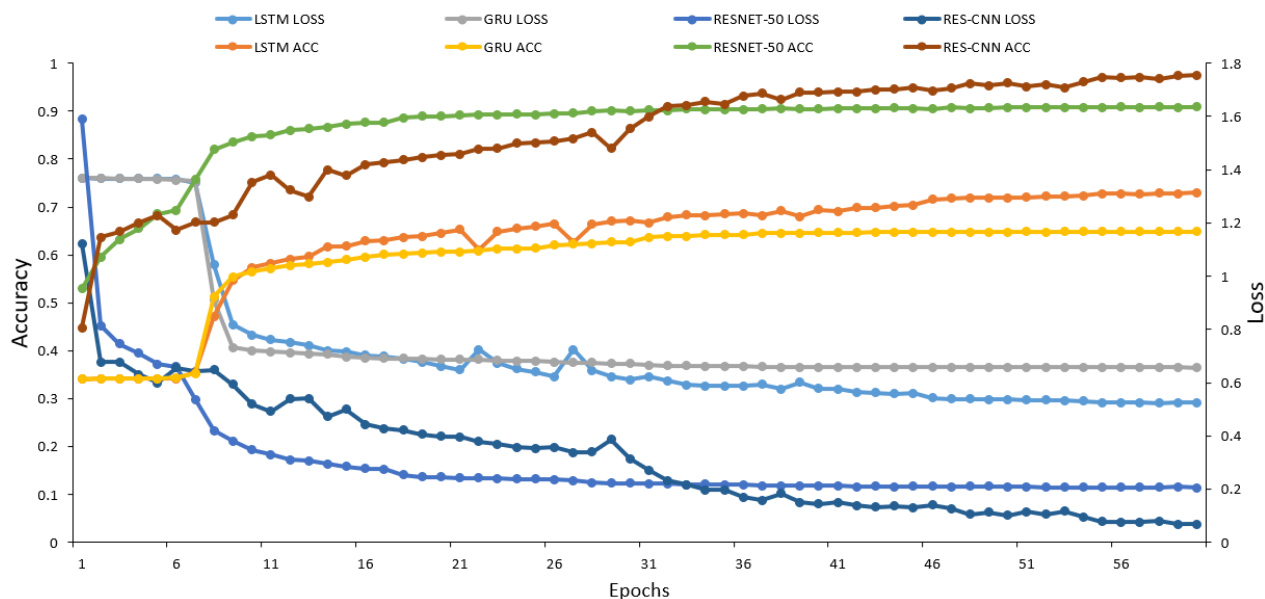

FIGURE 8. The comparison results of four different DNNs.

TABLE 4. The confusion matrix of all test samples of Res-CNN.

Label \ Result	Excellent	Good	Poor	Very poor
Excellent	1963	18	0	1
Good	80	1211	21	1
Poor	0	23	1018	255
Very poor	0	0	293	954

After plenty of training of different networks, the model with the best performance in the validation set is chosen as the final model, and their best performance is recorded in Table 5. We know that plain CNN has the shortest training time, and LSTM requires the most training time. The time of Res-CNN requires approximately 1/6 of LSTM’s training time. In addition, ResNet50 has the largest number of parameters of approximately 45,756,484, which possibly leads to overfitting. It is obvious that the parameter numbers of LSTM and GRU are almost the same. Due to the lack of agate in the structure, the training time of GRU is shorter than that of LSTM. Res-CNN takes the least time except for plain CNN, and it performs best.

TABLE 5. The trained models and their performances.

Type of DNN	Training time(s)	Number of parameters	Best loss in validation set	Best accuracy in validation set
LSTM	45925.97	289,028	0.60	0.67
GRU	36724.23	267,972	0.71	0.59
ResNet50	4892.44	45,756,484	0.31	0.87
Plain CNN	764.56	982,712	0.47	0.79
Res-CNN	839.27	982,712	0.36	0.90

According to the best loss and best accuracy in the validation set, GRU has the worst performance, and Res-CNN has the best performance. After making an all-around consideration of the different DNNs, Res-CNN is an optimal choice for DC power quality evaluation, which has higher classification precision and less training time cost.

IV. CONCLUSION

Due to the wide application of AC power, most of the current research on power quality evaluation is aimed at AC power. Although DC distribution is believed to be a very promising power supply mode in the future, few people have focused on DC power quality evaluation research. To address this issue, a DC power quality evaluation framework consisting of EMD and 1D-CNN is proposed. First, EMD decomposes the electrical signal into several IMFs, and then the 1D-CNN with residual module extracts features from them automatically and gives a comprehensive quality evaluation result of the sampled mass data with high efficiency. In addition, a comprehensive comparison with other advanced DNNs is conducted in real cases, including LSTM, GRU and ResNet50. The experimental results show that the proposed network has higher accuracy, lower loss, and lower time consumption compared with other DNNs. In conclusion, the proposed method is an effective approach for evaluating DC power quality, especially for the current stage in which the standard of DC power quality is not yet issued, but renewable energy is in significant growth.

REFERENCES

[1] National Energy Administration of China. (Nov. 2016). *Wind Energy Development Plan for the Thirteen Five-Year Period*. [Online]. Available: <http://news.bjx.com.cn/html/20161129/792710.shtml>

- [2] V. Prabhala, B. Baddipadiga, P. Fajri, and M. Ferdowsi, "An overview of direct current distribution system architectures & benefits," *Energies*, vol. 11, no. 9, pp. 2463–2483, Nov. 2018.
- [3] D. Jovicic, G. Tang, and H. Pang, "Adopting circuit breakers for high-voltage DC networks: Appropriating the vast advantages of DC transmission grids," *IEEE Power Energy Mag.*, vol. 17, no. 3, pp. 82–93, May 2019.
- [4] G. D. D. Freitas, B. Ismail, A. Bertinato, B. Raison, E. Niel, S. Poullain, and B. Luscan, "Assessment methodology and performance indicators for HVDC grid protection strategies," *J. Eng.*, vol. 2018, no. 15, pp. 1002–1006, Oct. 2018.
- [5] C. K. Das, O. Bass, T. S. Mahmoud, G. Kothapalli, N. Mousavi, D. Habibi, and M. A. S. Masoum, "Optimal allocation of distributed energy storage systems to improve performance and power quality of distribution networks," *Appl. Energy*, vol. 252, Oct. 2019, Art. no. 113468.
- [6] Y. Naderi, S. H. Hosseini, S. G. Zadeh, B. Mohammadi-Ivatloo, J. C. Vasquez, and J. M. Guerrero, "An overview of power quality enhancement techniques applied to distributed generation in electrical distribution networks," *Renew. Sustain. Energy Rev.*, vol. 93, pp. 201–214, Oct. 2018.
- [7] T. Adrikowski, D. Bu, and M. Pasko, "Reduction of conducted emission in a three-phase active power filter in accordance with the IEC 61000-6-4 standard," in *Proc. App. Electr. Eng.*, Kościelisko, Poland, Jun. 2019, pp. 1–5.
- [8] *IEEE Recommended Practices and Requirements for Harmonic Control in Electrical Power Systems*, IEEE Standard 519, 2014.
- [9] *IEEE Recommended Practice for Power Quality Data Interchange Format*, IEEE Standard 1159.3, 2019.
- [10] G. S. Elbasuony, S. H. E. A. Aleem, A. M. Ibrahim, and A. M. Sharaf, "A unified index for power quality evaluation in distributed generation systems," *Energy*, vol. 149, pp. 607–622, Apr. 2018.
- [11] S. J. Panneerselvam and S. Dhandapani, "Analysis of sensor trapped power quality indices using empirical wavelet transform and rational dilation wavelet transform to achieve high accuracy and frequency resolution," *Sensor Lett.*, vol. 17, no. 4, pp. 323–336, Apr. 2019.
- [12] T. Zhong, S. Zhang, G. Cai, Y. Li, B. Yang, and Y. Chen, "Power quality disturbance recognition based on multiresolution s-transform and decision tree," *IEEE Access*, vol. 7, pp. 88380–88392, 2019.
- [13] S. Majumdar and A. K. Mishra, "Empirical mode decomposition with wavelet transform based analytic signal for power quality assessment," *Int. J. Electron. Commun. Eng.*, vol. 12, no. 4, pp. 329–334, Mar. 2018.
- [14] B. Kiruthiga, R. N. Banu, and D. Devaraj, "Detection and classification of power quality disturbances or events by adaptive NFS classifier," *Soft Comput.*, vol. 7, pp. 1–12, Nov. 2019.
- [15] A. Shaik and A. Reddy, "Flexible entropy based feature selection and multi class SVM for detection and classification of power quality disturbances," *Int. J. Intell. Eng. Syst.*, vol. 11, no. 5, pp. 140–151, Aug. 2018.
- [16] W. Qiu, Q. Tang, J. Liu, and W. Yao, "An automatic identification framework for complex power quality disturbances based on multifusion convolutional neural network," *IEEE Trans. Ind. Informat.*, vol. 16, no. 5, pp. 3233–3241, May 2020.
- [17] K. Cai, W. Cao, L. Aarniovuori, H. Pang, Y. Lin, and G. Li, "Classification of power quality disturbances using Wigner-Ville distribution and deep convolutional neural networks," *IEEE Access*, vol. 7, pp. 119099–119109, 2019.
- [18] N. Fuyin, L. Zhengming, and P. Tianhong, "Power quality evaluation of distribution network containing microgrid based on PCNN," *Open Electr. Eng. J.*, vol. 9, no. 1, pp. 160–165, May 2015.
- [19] M. Sahani and P. K. Dash, "Automatic power quality events recognition based on Hilbert Huang transform and weighted bidirectional extreme learning machine," *IEEE Trans. Ind. Informat.*, vol. 14, no. 9, pp. 3849–3858, Sep. 2018.
- [20] C. Naik, F. Hafiz, A. Swain, and A. Kar, "Classification of power quality events using wavelet packet transform and extreme learning machine," in *Proc. IEEE 2nd SPEC*, Auckland, New Zealand, Dec. 2016, pp. 1–6.
- [21] A. D. Femine, D. Gallo, C. Landi, and M. Luiso, "Discussion on DC and AC power quality assessment in railway traction supply systems," in *Proc. IEEE Int. Instrum. Meas. Technol. Conf. (IMTC)*, Auckland, New Zealand, May 2019, pp. 1–6.
- [22] J. Barros, M. de Apráz, and R. Diego, "Power quality in DC distribution networks," *Energies*, vol. 12, no. 5, p. 848, Mar. 2019.
- [23] Y. Xu, Z. Zhai, X. Kang, M. Guo, and X. Ma, "Coordination control of medium-voltage hybrid AC/DC distribution," *J. Eng.*, vol. 2019, no. 16, pp. 910–916, Mar. 2019.
- [24] G. Van den Broeck, J. Stuyts, and J. Driesen, "A critical review of power quality standards and definitions applied to DC microgrids," *Appl. Energy*, vol. 229, pp. 281–288, Nov. 2018.
- [25] E. Hossain, M. R. Tur, S. Padmanaban, S. Ay, and I. Khan, "Analysis and mitigation of power quality issues in distributed generation systems using custom power devices," *IEEE Access*, vol. 6, pp. 16816–16833, 2018.
- [26] A. Kharrazi, V. Sreeram, and Y. Mishra, "Assessment techniques of the impact of grid-tied rooftop photovoltaic generation on the power quality of low voltage distribution network—A review," *Renew. Sustain. Energy Rev.*, vol. 120, Mar. 2020, Art. no. 109643.
- [27] Shivam and R. Dahiya, "Distributed control for DC microgrid based on optimized droop parameters," *IETE J. Res.*, vol. 45, no. 19, pp. 1–12, Jun. 2018.
- [28] S. Chreang and P. Kumhom, "A study of nonlinear DC and AC loads connected to PV microgrid," in *Proc. 5th Int. Conf. Bus. Ind. Res. (ICBIR)*, Bangkok, Thailand, May 2018, pp. 309–313.
- [29] J. Sun, M. Li, Z. Zhang, T. Xu, J. He, H. Wang, and G. Li, "Renewable energy transmission by HVDC across the continent: System challenges and opportunities," *CSEE J. Power Energy*, vol. 3, no. 4, pp. 353–364, Dec. 2017.
- [30] D. Kai, L. Wei, H. Yuchuan, H. Yuchuan, H. Pan, and Q. Yimin, "Power quality comprehensive evaluation for low-voltage DC power distribution system," in *Proc. IEEE 3rd Inf. Technol., Netw., Electron. Automat. Control Conf. (ITNEC)*, Chengdu, China, Mar. 2019, pp. 1027–1077.
- [31] I. Ciomei, M. Albu, M. Sanduleac, L. Hadjdemetriou, and E. Kyriakides, "Analytical derivation of PQ indicators compatible with control strategies for DC microgrids," in *Proc. IEEE Manchester PowerTech*, Manchester, U.K., Jun. 2017, pp. 1–6.
- [32] H. Lv, L. Tian, and Z. Wang, "Power quality comprehensive evaluation of DC distribution network based on maximizing deviation and fuzzy matter-element model," in *Proc. Int. Conf. Electron. Electr. Eng. Technol. (EET)*, Tianjin, China, Sep. 2018, pp. 22–26.
- [33] S. Lan, M.-J. Chen, and D.-Y. Chen, "A novel HVDC double-terminal non-synchronous fault location method based on convolutional neural network," *IEEE Trans. Power Del.*, vol. 34, no. 3, pp. 848–857, Jun. 2019.
- [34] J. Wang, W. Pang, L. Wang, X. Pang, and R. Yokoyama, "Synthetic evaluation of steady-state power quality based on combination weighting and principal component projection method," *CSEE J. Power Energy*, vol. 3, no. 2, pp. 160–166, Jul. 2017.
- [35] S. Wang and H. Chen, "A novel deep learning method for the classification of power quality disturbances using deep convolutional neural network," *Appl. Energy*, vol. 235, pp. 1126–1140, Feb. 2019.
- [36] N. E. Huang, Z. Shen, S. R. Long, M. C. Wu, H. H. Shih, Q. Zheng, N.-C. Yen, C. C. Tung, and H. H. Liu, "The empirical mode decomposition and the Hilbert spectrum for nonlinear and non-stationary time series analysis," *Proc. Roy. Soc. London A, Math., Phys. Eng. Sci.*, vol. 454, no. 1971, pp. 903–995, Mar. 1998.
- [37] I. Goodfellow, Y. Bengio, and A. Courville, *Deep Learning*. Cambridge, MA, USA: MIT Press, 2016, pp. 163–217.
- [38] *Electromagnetic Compatibility (EMC)—Part 4-29: Testing and Measurement Techniques—Voltage Dips, Short Interruptions and Voltage Variations on D.C. Input Power Port Immunity Tests*, Standard IEC61000-4-29, 2000.
- [39] *Assessment of Power Quality—Characteristics of Electricity Supplied By Public Networks*, Standard IEC TS 62749, 2015.
- [40] *IEEE Recommended Practice for Electronic Power Subsystems: Parameter Definitions, Test Conditions, and Test Methods*, IEEE Standard 1515, 2000.
- [41] Y. Dong, Y. Liu, and Z. Yin, "A comprehensive combinatorial weighting method for power quality evaluation based on maximization deviation," in *Proc. 2nd IEEE Conf. Energy Internet Energy Syst. Integr. (EI)*, Beijing, China, Oct. 2018, pp. 1–6.
- [42] Z. Ling and R. C. Qiu, "Spectrum concentration in deep residual learning: A free probability approach," *IEEE Access*, vol. 7, pp. 105212–105223, 2019.
- [43] K. Rahul and M. Tripathi, "Long short-term memory-convolution neural network based hybrid deep learning approach for power quality," in *Proc. ICIECE*, Hyderabad, India, Jul. 2018, pp. 501–510.
- [44] K. Wang, X. Qi, and H. Liu, "Photovoltaic power forecasting based LSTM-Convolutional Network," *Energy*, vol. 189, Dec. 2019, Art. no. 116225.
- [45] S. Hochreiter and J. Schmidhuber, "Long short-term memory," *Neural Comput.*, vol. 9, no. 8, pp. 1735–1780, Mar. 1997.
- [46] Y. Deng, L. Wang, H. Jia, X. Tong, and F. Li, "A sequence-to-sequence deep learning architecture based on bidirectional GRU for type recognition and time location of combined power quality disturbance," *IEEE Trans. Ind. Informat.*, vol. 15, no. 8, pp. 4481–4493, Aug. 2019.

- [47] X. Gao, X. Li, B. Zhao, W. Ji, X. Jing, and Y. He, "Short-term electricity load forecasting model based on EMD-GRU with feature selection," *Energies*, vol. 12, no. 6, pp. 1140–1158, Mar. 2019.
- [48] A. Mahajan and S. Chaudhary, "Categorical image classification based on representational deep network (RESNET)," in *Proc. 3rd ICECA*, Tamil Nadu, India, Jun. 2019, pp. 327–330.
- [49] D. P. Kingma and J. Ba, "Adam: A method for stochastic optimization," 2014, *arXiv:1412.6980*. [Online]. Available: <http://arxiv.org/abs/1412.6980>
- [50] K. Dragomiretskiy and D. Zosso, "Variational mode decomposition," *IEEE Trans. Signal Process.*, vol. 62, no. 3, pp. 531–544, Feb. 2014.
- [51] L. Fu, T. Zhu, G. Pan, S. Chen, Q. Zhong, and Y. Wei, "Power quality disturbance recognition using VMD-based feature extraction and heuristic feature selection," *Appl. Sci.*, vol. 9, no. 22, pp. 4901–4923, Nov. 2019.
- [52] Y. Xu, Y. Gao, Z. Li, and M. Lu, "Detection and classification of power quality disturbances in distribution network based on VMD and DFA," *CSEE J. Power Energy Syst.*, vol. 6, no. 2, pp. 1–9, Aug. 2019.
- [53] C. Dou and J. Lin, "Extraction of fault features of machinery based on Fourier decomposition method," *IEEE Access*, vol. 7, pp. 183468–183478, 2019.



QINGXIAN LI was born in 1964. He received the bachelor's degree from the Huazhong University of Science and Technology, in 1986. He is currently working with the Hunan Institute of Metrology and Test, China. His current field of expertise is measurement technology research and management.



JUN MING was born in 1996. She received the bachelor's degree from Central China Normal University, in 2018. She is currently pursuing the M.S. degree with the School of Electronic Information, Wuhan University, China. Her current research interest is power quality evaluation.



HUIXIN LI was born in 1998. She received the bachelor's degree from the Wuhan University of Technology, in 2019. She is currently pursuing the M.S. degree with the School of Electronic Information, Wuhan University, China. Her current research interest is power quality evaluation.



BENSHUN YI was born in 1965. He received the Ph.D. degree in electrical engineering from the Huazhong University of Science and Technology. He is currently a Professor with the School of Electronic Information, Wuhan University, China. His research interests include power quality, wireless networks, and channel coding. He has published extensively in these areas.



ZHIGANG ZHAO was born in 1981. He received the bachelor's degree from Chongqing University, in 2003. He is currently working with Gree Electric Appliances, Inc., China. He is currently specialized in the energy Internet and clean energy.

• • •