

Received November 23, 2019, accepted January 15, 2020, date of publication February 4, 2020, date of current version March 6, 2020.

Digital Object Identifier 10.1109/ACCESS.2020.2971632

Can Wearable Devices Facilitate a Driver's Brake Response Time in a Classic Car-Following Task?

AO ZHU¹, SHI CAO², HAN YAO¹, MURTUZA JADLIWALA³, (Member, IEEE),
AND JIBO HE¹

¹Department of Psychology, Tsinghua University, Beijing 100871, China

²Department of Systems Design Engineering, University of Waterloo, Waterloo, ON N2L 3G1, Canada

³Department of Computer Science, The University of Texas at San Antonio, San Antonio, TX 78249, USA

Corresponding author: Jibo He (hejibo666@tsinghua.edu.cn)

This work was supported by the National Science Foundation (NSF) under Award CNS-1829066.

ABSTRACT Effective warnings of potential collision risks are important countermeasures for drowsy and distracted driving. This study explores the possibility of using smart wearable devices to provide vibrotactile warnings. We assessed the effectiveness of a vibrating wearable device as a warning system. Participants performed a classic car-following task in a driving simulator under four conditions: no warning, warnings at the finger, wrist, temple area. When the lead vehicle braked intermittently, warnings would be delivered to the same vibrating device, which was placed at the finger, wrist, or temple area. Results showed that warnings at the finger and the wrist produced shorter brake response time than the no warning condition. Warnings at the temple area did not produce significant benefits in brake response time over the no warning condition. Participants preferred warnings at the finger and the wrist than the temple area. Quicker brake response time for warnings at the finger and wrist area may be explained by the relative sizes of cortex area in the brain which corresponds to the sensory organs, as visualized by the classic Penfield Homunculus. The current study of wearable tactile warnings can inform future designs of warning systems for drivers.

INDEX TERMS Wearable devices, collision warning system, tactile warnings, car following task, driving simulator.

I. INTRODUCTION

One of the most important parts of vehicle information interfaces is to warn drivers of potential collisions. Designing warning systems for drowsy and distracted driving plays a significant role in reducing traffic accidents such as serial crashes and highway pileups [1]. Warning design is also important for partially autonomous vehicles. In a take-over control scenario, take-over warnings must be designed properly to minimize brake response time. A well-designed warning system can not only facilitate a faster response time but also elicit appropriate behavioral responses [2]. The focus of the current study is to compare different body location placement of wearable vibrotactile devices for facilitating drivers' emergency responses, specifically braking responses in a simulated classic car-following task.

As drivers have limited attention resources, the primary driving and other secondary tasks (such as talking and texting while driving) may interfere with each other [3]. Since driving

is primarily a visual-manual-cognitive task, warning signals presented to drivers via the auditory and tactile modalities are expected to be more effective than that presented via the visual modality [4]. According to Wickens' Multiple Resource Theory, different perceptual modalities such as visual, auditory, and tactile have separate resources [5]–[8]. Two tasks using different resources are expected to have less interference than tasks utilizing the same resources. It is also important to point out that tasks utilizing different perceptual modalities still interfere with each other. As the bottleneck of the central executive resources persists [9] and attentional resources for different perceptual modalities may be linked according to the research about cross-modality attention, the interference may be less. A series of research by Dr. Spence's group suggests that information from multiple sensory channels is integrated to produce a coherent multi-sensory perception of the outside world, such as tactile cues that help visual selective attention [10].

Visual warnings are one of the traditional warning modalities, as driving is primarily a visual task. Excessive visual demand leads to impaired driving performance, such as

The associate editor coordinating the review of this manuscript and approving it for publication was Lei Wei¹.

reduced driving speed and increased lane-keeping variation [11]. It has long been acknowledged that drivers often suffer from visual overload [12]. Thus, warning systems should not overload drivers' visual resources [6]. Past studies have also pointed out that an increasing amount of complex in-vehicle technologies may distract drivers' attention [13], [14]. In fact, high-load tasks can reduce the perceptual processing of task-related information. This phenomenon is often referred to as *inattentive blindness* [15], [16], including incorrect identification of meaningful stimuli or *looked-but-failed-to-see* errors [17]–[19].

Auditory warnings overcome the limitations of visual warnings and can attract drivers' attention regardless of where they are looking at [20]. Auditory warnings, combined with semantic contents of risk levels or perceived urgency, may be an effective modality for delivering warnings [21], [22]. A previous study by Ho and Spence showed that peripersonal auditory warnings, i.e., the warnings from the space nearby the driver, were possibly an effective way to reorient the driver's gaze [23]. However, some studies have found that high attentional demand can also impair the perception of auditory warnings [24], [25] causing *inattentive deafness* [26], [27]. In addition, background sounds such as music or engine noises may further reduce the effectiveness of auditory warnings [28], [29].

With the limitation of visual and auditory warning devices, increasing attention has been paid to tactile warnings [30]. Tactile warnings have been used in various fields, such as aviation [31] and learning [32]. Evidence from previous analyses showed that tactile warnings can improve drivers' response to potential car-following collisions [33]–[36]. Existing studies have examined different types of tactile warning devices, for example, vibration vest [37], vibration seat [38], and vibration seat belt [29], [33], [39]. Despite the novelty and importance of these studies, tactile vibration warning systems have not been commonly adopted in vehicles. While their cost may be a factor, it has been pointed out that vibration signals from the seat, steering wheel, pedal, or seat belt could be reduced by thick clothing and gloves [4]. With the development of wearable devices, this problem may be solved by tactile warnings delivered directly onto the skin via smart glasses, smart watches or smart rings. A practical research question in the current study is how effective and how acceptable wearable devices are as an approach for delivering tactile warnings to drivers.

The current study investigates two critical theoretical questions: The first question is to find out the underlining mechanism in determining tactile response time, and the second question is to examine whether the tactile response time is determined by the size of the cortex areas corresponding to the stimulation skin site (cortex sensory mapping hypothesis), or by the distance to the central nervous system (sensory distance hypothesis).

The *cortex sensory mapping hypothesis* is inspired by the Penfield Homunculus [40], which suggests a topographic correspondence between body sensory areas and the brain cortex

for sensory and motor processing [41]. This is also supported by Weinstein's study on skin sensitivity which shows that the two-point threshold of the hand is the shortest, followed by the head region [42]. According to this hypothesis, it is better to place tactile warnings on skin sensory areas with a larger percentage of cortex correspondence, such as the wrist and finger area.

The *sensory distance hypothesis* proposes that the response time to tactile sensation is proportional to the distance from the sensory area to the central nervous system. One former study found that the reaction time to touches on different sites along the body was proportional to the distance from the brain [43]. For instance, Lele [44] found that the response time of the proximal area of the finger was shorter than that from the distal area, such as the foot. According to this hypothesis, it is better to place vibration warnings on skin sensory areas closer to the central nervous system, such as the temple area.

To answer the theoretical and practical questions, we used a simulated classic car-following task with tactile warnings for forward collisions to evaluate the driver's brake response time to warnings delivered at different skin areas. The same tactile vibrator was placed on the finger, the wrist, or the temple area to deliver warnings. A no-warning condition was used as the baseline.

II. METHODS

A. PARTICIPANTS

Twenty-eight participants were recruited from the community of Tsinghua University. We used G-power (version 3.1.9.4) to estimate the sample size. The effect size parameter were set as the medium effect size ($\eta_p^2 = 0.06$), and the others were set by default. The results showed that 23 subjects were needed under 80% power and 30 subjects were needed under 90% power. Considering previous study and Latin square design, we used 28 subjects [45]. The results from 24 participants were included in the data analysis. Three participants did not follow the experiment instructions and resulted in over 10 collisions, and one participant chose to withdraw from the study. The mean age of the 24 valid participants was 23.88 years old ($SD = 6.62$ years), and there were 17 males and 7 females. All participants reported having a normal or corrected-to-normal vision, a healthy body, a valid driving license, and a driving experience for over a year.

B. APPARATUS

The driving simulator (as shown in Figure 1) consisted of a Logitech G29 steering wheel and gearbox. The screen used was a Philips 58-inch LCD with a screen ratio of 16:9, a screen resolution of 4096×2160 pixels, and a screen refresh frequency of 60 Hz. The custom modified TORCS ("http://torcs.sourceforge.net") software was used for the driving simulation, which has been used in previous research of driver braking behaviors [45], [46].



FIGURE 1. The driving simulator and the tactile vibrator (on his right hand as highlighted in the red circle).

The vibrator's main control chip was Atmel 328P. The main components were a charging chip TP4056, LDO 662K, and an HC-05 Bluetooth module. The power of the vibration motor was 0.375 W. The size of the vibrator was 10×2.7 mm. A trained technician with a master's degree in Automation Control Engineering major from Haoxing Technologies measured the frequency and amplitude of the vibrator on the skin using a hand-held AR63A/AS63A vibrometer. The results showed that the vibration frequency was 200 Hz, and the acceleration was 0.9 m/s^2 when it was attached to human skin. The vibrator was designed, coded and manufactured according to the International Organization for Standardization (ISO) [47], [48].

C. EXPERIMENTAL TASK

A car-following task was used to measure the brake response time and response rate under different conditions. Participants were instructed to follow the car in front of them and maintain a two-second headway behind it. The lead car drove at a mean velocity of 40 mph (64.4 km/h) and braked at a random time interval from 30 to 60 seconds. Vehicle dynamic measurements, including the brake response time, brake response rate, headway distance, lane position, speed, and steering wheel position, were recorded during the execution of the simulated driving tasks.

The vibrator (if worn) would warn the participants to brake when the lead car was braking. The taillights of the lead vehicle were illuminated every time the lead vehicle braked. Participants were instructed to brake as soon as possible when the lead vehicle started braking, even when a braking manipulation was not required by the driving scenarios.

1) EXPERIMENTAL DESIGN

The experimental session consisted of one block of 13 practice trials followed by four blocks of experimental trials, with 13 trials in each block and a total of 52 experimental trials. The experiment adopted a single-factor within-subject

design to explore which body part could allow the quickest brake responses. The independent variable was the body part wearing the vibrator, including the index finger of their right hand, the wrist, the head temple area, and no warning. These four conditions were counter-balanced using the Latin square design.

2) PROCEDURE

After arriving at the laboratory, participants read the instructions and signed the consent form. Next, they completed a questionnaire regarding their driving and video game playing experience. Once they finished the practice trials and reported no doubt about the experiment, they began to perform the car-following task under four conditions in counterbalanced orders according to Latin Square design. Each condition included 13 trials, lasting approximately 12 minutes. Participants rested two minutes between conditions. Finally, they were asked to fill in another questionnaire about their subjective opinions and preference for the body parts wearing the vibrator.

3) DATA ANALYSIS

Driving performance was measured using the brake response rate and brake response time. A brake response was operationally defined as a minimal depression of 1% of brake pedal [45], [49], [50]. A "no-braking" response was operationally defined as a failure to brake within 5 seconds after the lead vehicle braked. The brake response rate was calculated by dividing the number of successful brakes by the total number of brakes executed by the lead vehicle. Brake response time was measured by recording the time between the onset of the lead vehicle braking and the initiation of a brake response by the participant's vehicle.

The preferred and perceived intensities of vibration, asked after the participant finished all the tasks, were measured by a seven-point Likert scale, with 1 stands for "dislike the most" and "weak feeling", while 7 stands for "like the most" and "strong feeling".

All these measurements were submitted to repeated-measure ANOVA with the task condition as the only within-subject factor. IBM SPSS v25.0 was used in the statistical analysis. Bonferroni correction was used for all post hoc comparisons.

III. RESULTS

A repeated-measure ANOVA on brake response rate revealed a significant main effect of wearing position, $F(3, 69) = 3.67$, $p = .04$, $\eta_p^2 = 0.14$. Yet, post hoc pairwise comparisons, as shown in Figure 3, produced no significant results.

Brake response time differed significantly across all task conditions, $F(3, 69) = 4.76$, $p < .01$, $\eta_p^2 = 0.17$. As shown in Figure 4, post hoc comparisons showed that the brake response time under the finger condition ($M = 1.04 \text{ s}$, $SD = 0.35 \text{ s}$) and the wrist condition ($M = 1.00 \text{ s}$, $SD = 0.33 \text{ s}$) were significantly shorter than under driving-only condition ($M = 1.29 \text{ s}$, $SD = 0.36 \text{ s}$) with $p = .004$ and $p = .008$



FIGURE 2. Car following task in TORCS.

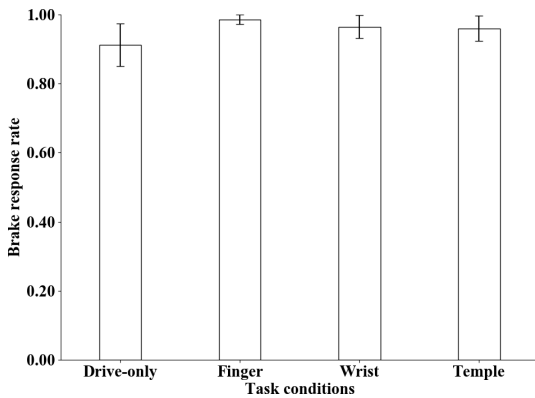

FIGURE 3. Brake response rate. Error bars in all figures indicate within-subject standard errors based on the main effect of the task.

respectively, whereas wearing vibrator on the temple ($M = 1.08$ s, $SD = 0.50$ s) had no significant difference with the driving-only condition ($p = .22$).

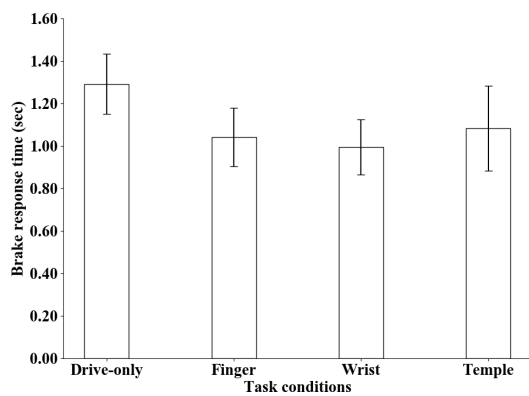

FIGURE 4. Brake response time.

Participants' preference differed significantly across three wearing positions, $F(2, 46) = 7.05$, $p < .01$, $\eta_p^2 = 0.23$. As shown in Figure 5, the preference for finger ($M = 4.88$, $SD = 1.75$) and wrist ($M = 4.83$, $SD = 1.31$) was higher than the temple ($M = 3.13$, $SD = 2.05$) with $p = .03$ and $p = .02$ respectively, while no difference between finger and wrist was found ($p > .10$).

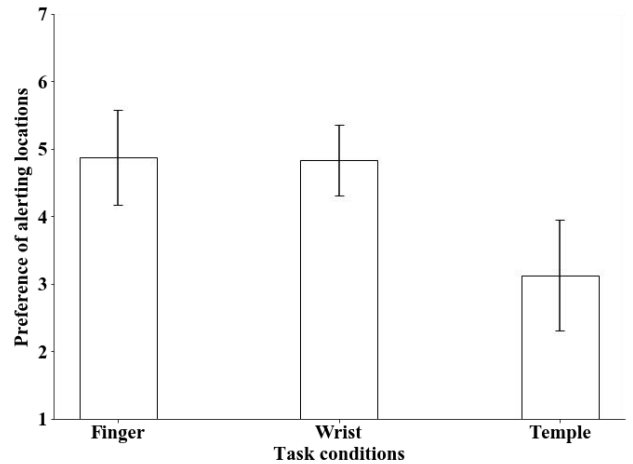

FIGURE 5. Preference of warning locations (1 represents dislike the most, 7 represents like the most).

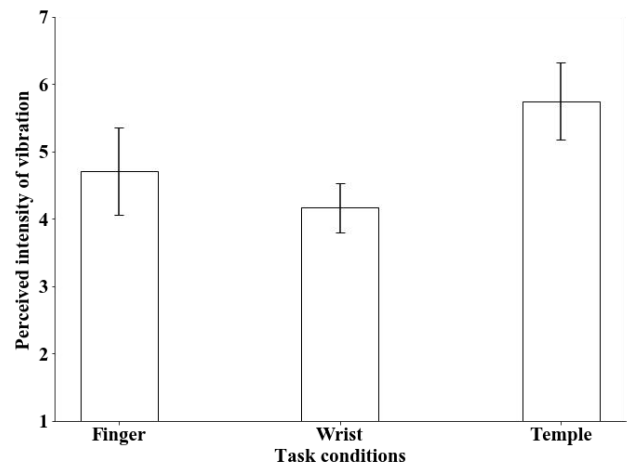

FIGURE 6. Perceived intensity of vibration (1 represents a weak feeling, 7 represents a strong feeling).

Participants' perceived intensity of vibration also produced a significant main effect of task conditions, $F(2, 46) = 7.37$, $p < .01$, $\eta_p^2 = 0.24$. As shown in Figure 6, the perceived intensity when wearing on the wrist ($M = 4.17$, $SD = 0.92$) was lower than the temple ($M = 5.75$, $SD = 1.42$), $p < .01$, whereas wearing on the finger ($M = 4.71$, $SD = 1.63$) showed neither significant difference with the temple ($p = .09$) nor with the wrist ($p = .56$).

IV. DISCUSSIONS

The current study found that the vibration warning effect on the finger and wrist was better than the driving-only condition without warnings. Yet, the effect of the warning executed on the temple area was no better than the driving-only condition. The results are consistent with the *cortex sensory mapping hypothesis*. It is concluded that the brake response time of warning is faster by using body parts that have a larger correspondence area in the brain cortex. However, the warning effect of the temple area, which is closer to the central nervous system, is no better than the driving-only, the finger warning, and wrist warning conditions, thus rejecting the

sensory distance hypothesis. In Mancini and colleagues' study on the whole-body mapping of spatial acuity for pain and touch, they also found opposite evidence of touch sensitivity to the prediction of *sensory distance hypothesis* [51]. The sensory distance hypothesis may seem to be an intuitively viable explanation. However, the conduction speed of nerve impulses is at the rate of 100 m/s [52]. Thus, the difference in conduction time or distance may be negligible compared to the number of neurons devoted to processing the information in the somatosensory cortex. According to the estimate by Bergenheim and colleagues, the conduction time difference between the foot and arm stimulus ranged from 17.1 ms to 35.21 ms [53]. The maximum magnitude of conduction time difference of 35.21 ms between the foot and the arm is smaller than the tactile brake response time difference between the wrist and the temple area ($297 - 210 = 87$ ms), and the finger and the temple area ($251 - 210 = 41$ ms), which is contrary to the expectation of the sensory distance hypothesis. The sensory distance hypothesis would expect a longer tactile response time in the wrist and finger area than the temple area.

From a theoretical perspective, the current results provided support for the *cortex sensory mapping hypothesis*. Response time to tactile warnings depends more on the amount of cortex sensory mapping to the skin sensory area, rather than the distance of the skin area to the central nervous system. Prior research and the current study gave us the inspiration to place the vibrotactile device on sensitive body parts, such as the finger or the wrist.

More factors, not only cortex sensory mapping, but also practices [42], skin type (glabrous versus hairy) [51], age, and gender [54], may also impact tactile response time. This simulated driving study provides empirical evidence supporting the cortex sensory mapping hypothesis and rejects the sensory distance hypothesis. Our conclusion, which is based on inductive reasoning instead of deductive reasoning, only suggests that the amount of cortex sensory mapping plays a more important role than the sensory distance in determining tactile reasoning. Still, this does not imply that the cortex sensory mapping hypothesis is the only viable explanation or the only factors or the most influential factors in influencing tactile response time. For example, long-term meditations or practices can improve tactile sensitivity [42]; the hair type also influences touch sensitivity, as glabrous skin is observed to be more sensitive to touch than hairy skin [51]. Older people have poorer tactile discriminability than younger people as a result of the changes in the nervous systems as people age [54]. Future fundamental neurological studies should be conducted to investigate the most decisive influencing factors in determining tactile response time. Nonetheless, our empirical applied study has provided evidence suggesting that the cortex sensory mapping is at least more influential than sensory distance.

From a practical perspective, it would be less expensive and more feasible to use a smart ring, smartwatch or smart glasses for vibration warning than to use the vibration seat or vibration vest for vibration warning. In addition, considering

people's wearing preference in daily life, decoration devices such as rings, watches, and fashion glasses are preferred wearable equipment. In comparison, it is less practical for people to wear vibration warning vests while driving, as drivers are more reluctant to put on a vest each time prior to driving [55].

The current study confirmed the efficacy of tactile cues in producing quick brake responses. Compared with the driving-only condition without tactile warning, the average brake response time was reduced by 297 ms when the participants wore the device on the wrist, 251 ms for the finger, and 210 ms for the temple. At a cruising speed of 40 mph (64.4 km/h), a reduced brake response time of 297 ms can reduce the stopping distance of 5.31 m. At a cruising speed of 70 mph (112.7 km/h), the stopping distance reduced can be as far as 9.29 m. Moreover, the wrist warning condition decreased the brake response time by 23% compared to the drive-only condition. In comparison, making phone calls while driving can only increase the brake response time by 9% [49].

The present simulated driving study has its limitations, as a driving simulator cannot fully simulate the real-world driving situation which has additional motion feedback. Perception of danger and intensity of tactile stimulation may differ between the real-world and simulated world, which may lead to potential differences in tactile brake response time [56]. For instance, a vehicle running on real roads vibrates because of the unevenness of roads, but no vehicle vibration was provided in this simulated study. The frequency of warnings in the experiment may also be higher than in real-world driving. These factors are common limitations regarding the external validity of simulated laboratory studies; however, it has been pointed out that laboratory studies have its advantages, such as allowing the control of perceptual load to reveal the effect of multisensory cue benefits [57]. Simulated laboratory experiments and real-world driving studies are complementary research approaches. Additionally, although tactile warnings at the temple area did not provide significant benefits compared to no warning condition. The lack of benefits at the temple area may be specific to the current car-following task. As peripersonal warning signals were reported to be effective at orienting a driver's gaze [23], tactile warnings at the temple area may be effective in a lane change task, which needs left/right directional information. Future studies should consider using various driving tasks, such as a lane change task, in addition to the current car following task to compare the effectiveness of tactile warnings at different locations.

Future studies can improve the current study in many aspects. We only investigated the effect of three different body parts with vibration warning. Future studies can expand the scope, such as arranging the vibration equipment on the chest (where a necklace is located), or behind the ear (where earrings are located), which will provide more alternative locations for wearable devices. Meanwhile, Sutherland *et al.* [58] found cortical representation was larger for the index finger than the little finger, and that for the middle finger is larger than the ring finger. This study only

tested on participants' index fingers. It will be interesting to compare the differences between different fingers and hand areas. Besides, a study conducted by Ho and Spence explored the relationship between the tactile target location and the effector, which shows that participants are able to detect vibrations and react more quickly on the wrist than on the shin. Similarly, the study of the target position and the effector (shin) in the driving task is also an important research topic [59].

In addition, the experiment did not cross-compare with the equipment in the previous studies, such as vibration seat [38], belts [29], [33], [39] and vest [37]. Nevertheless, the current study provided design guidelines and support for the design of wearable tactile warning systems.

APPENDIX ELECTRONICS DESIGN FOR THE VIBRATOR

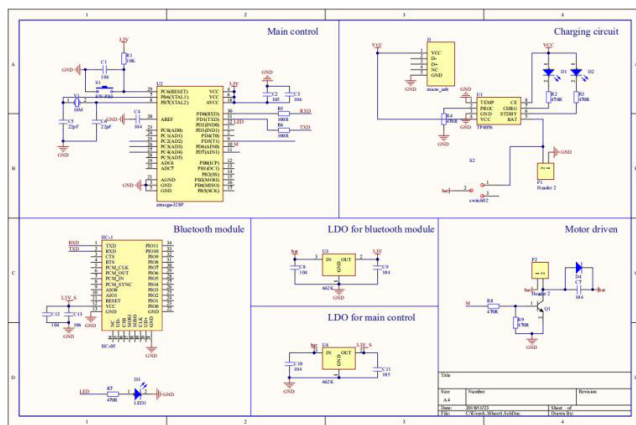

ACKNOWLEDGMENT

The authors would like to appreciate the technical support from Yunnan Hafnium Star Innovation Technology Company, Ltd., and the space support and inspiration from Prof. K. Peng at Tsinghua University. They are grateful for the graduate and undergraduate students for helping us collect data; their names are H. Xu, Y. Song, D. Hu, Y. Lin, J. Zhao, S. Liu, and A. T. H. Choi.

REFERENCES

- J. He, W. Choi, Y. Yang, J. Lu, X. Wu, and K. Peng, "Detection of driver drowsiness using wearable devices: A feasibility study of the proximity sensor," *Appl. Ergonom.*, vol. 65, pp. 473–480, Nov. 2017.
- R. Gray, C. Ho, and C. Spence, "A comparison of different informative vibrotactile forward collision warnings: Does the warning need to be linked to the collision event?" *PLoS ONE*, vol. 9, no. 1, Jan. 2014, Art. no. e87070.
- T. A. Ranney, J. L. Harbluk, and Y. I. Noy, "Effects of voice technology on test track driving performance: Implications for driver distraction," *Hum. Factors*, vol. 47, no. 2, pp. 439–454, Jun. 2005.
- F. Meng and C. Spence, "Tactile warning signals for in-vehicle systems," *Accident Anal. Prevention*, vol. 75, pp. 333–346, Feb. 2015.
- R. Parasuraman and D. R. Davies, *Varieties of Attention*. New York, NY, USA: Academic, 1984.
- C. D. Wickens, "Multiple resources and performance prediction," *Theor. Issues Ergonom. Sci.*, vol. 3, no. 2, pp. 159–177, Jan. 2002.
- C. D. Wickens, "Multiple resources and mental workload," *Hum. Factors*, vol. 50, no. 3, pp. 449–455, Jun. 2008.
- C. D. Wickens and J. G. Hollands, "Signal detection, information theory, and absolute judgment," in *Engineering Psychology and Human Performance*. New York, NY, USA: Psychology Press, vol. 2, 2000, pp. 24–73.
- J. Levy, H. Pashler, and E. Boer, "Central interference in driving: Is there any stopping the psychological refractory period?" *Psychol. Sci.*, vol. 17, no. 3, pp. 228–235, Mar. 2006.
- C. Ho and C. Spence, *The Multisensory Driver: Implications for Ergonomic Car Interface Design*. London, U.K.: CRC Press, 2008.
- J. Engström, E. Johansson, and J. Östlund, "Effects of visual and cognitive load in real and simulated motorway driving," *Transp. Res. F, Traffic Psychol. Behav.*, vol. 8, no. 2, pp. 97–120, Mar. 2005.
- C. Spence and C. Ho, "Tactile and multisensory spatial warning signals for drivers," *IEEE Trans. Haptics*, vol. 1, no. 2, pp. 121–129, Jul. 2008.
- S. Ashley, "Driving the info highway," *Sci. Amer.*, vol. 285, no. 4, pp. 52–58, Oct. 2001.
- J. D. Lee, B. Caven, S. Haake, and T. L. Brown, "Speech-based interaction with in-vehicle computers: The effect of speech-based e-mail on drivers' attention to the roadway," *Hum. Factors*, vol. 43, no. 4, pp. 631–640, Dec. 2001.
- D. J. Simons and D. T. Levin, "Change blindness," *Trends Cognit. Sci.*, vol. 1, no. 7, pp. 261–267, 1997.
- A. Mack and I. Rock, *Inattentional Blindness*. Cambridge, MA, USA: MIT Press, 1998.
- R. Jenkins, N. Lavie, and J. Driver, "Recognition memory for distractor faces depends on attentional load at exposure," *Psychonomic Bull. Rev.*, vol. 12, no. 2, pp. 314–320, Apr. 2005.
- N. Lavie, Z. Lin, N. Zokaei, and V. Thoma, "The role of perceptual load in object recognition," *J. Exp. Psychol., Hum. Perception Perform.*, vol. 35, no. 5, pp. 1346–1358, Oct. 2009.
- D. Carmel, P. Saker, G. Rees, and N. Lavie, "Perceptual load modulates conscious flicker perception," *J. Vis.*, vol. 7, no. 14, p. 14, Dec. 2007.
- C. L. Baldwin, "Verbal collision avoidance messages during simulated driving: Perceived urgency, alerting effectiveness and annoyance," *Ergonomics*, vol. 54, no. 4, pp. 328–337, Apr. 2011.
- J. Edworthy and N. Stanton, "A user-centred approach to the design and evaluation of auditory warning signals: 1. Methodology," *Ergonomics*, vol. 38, no. 11, pp. 2262–2280, Nov. 1995.
- J. Edworthy and E. Hellier, "Complex nonverbal auditory signals and speech warnings," in *Handbook of Warnings*, M. S. Wolgater, Ed. Boca Raton, FL, USA: CRC Press, 2006, pp. 199–220.
- C. Ho and C. Spence, "Using peripersonal warning signals to orient a driver's gaze," *Hum. Factors*, vol. 51, no. 4, pp. 539–556, Aug. 2009.
- C. Alain and A. Izenberg, "Effects of attentional load on auditory scene analysis," *J. Cognit. Neurosci.*, vol. 15, no. 7, pp. 1063–1073, Oct. 2003.
- S. Murphy, N. Fraenkel, and P. Dalton, "Perceptual load does not modulate auditory distractor processing," *Cognition*, vol. 129, no. 2, pp. 345–355, Nov. 2013.
- N. A. Parks, M. R. Hilimire, and P. M. Corballis, "Visual perceptual load modulates an auditory microreflex," *Psychophysiology*, vol. 46, no. 3, pp. 498–501, May 2009.
- J. S. P. Macdonald and N. Lavie, "Visual perceptual load induces inattention deafness," *Attention, Perception, Psychophys.*, vol. 73, no. 6, pp. 1780–1789, Aug. 2011.
- P. Wilkins and W. Acton, "Noise and accidents—A review," *Ann. Occupational Hygiene*, vol. 25, no. 3, pp. 249–260, 1982.
- R. Mohebbi, R. Gray, and H. Z. Tan, "Driver reaction time to tactile and auditory rear-end collision warnings while talking on a cell phone," *Hum. Factors*, vol. 51, no. 1, pp. 102–110, Feb. 2009.
- C. Ho, H. Z. Tan, and C. Spence, "Using spatial vibrotactile cues to direct visual attention in driving scenes," *Transp. Res. F, Traffic Psychol. Behav.*, vol. 8, no. 6, pp. 397–412, Nov. 2005.
- A. E. Sklar and N. B. Sarter, "Good vibrations: Tactile feedback in support of attention allocation and human-automation coordination in event-driven domains," *Hum. Factors*, vol. 41, no. 4, pp. 543–552, Dec. 1999.
- A. Chan, K. Maclean, and J. Mcgreneire, "Designing haptic icons to support collaborative turn-taking," *Int. J. Hum.-Comput. Stud.*, vol. 66, no. 5, pp. 333–355, May 2008.
- C. Ho, N. Reed, and C. Spence, "Assessing the effectiveness of 'intuitive' vibrotactile warning signals in preventing front-to-rear-end collisions in a driving simulator," *Accident Anal. Prevention*, vol. 38, no. 5, pp. 988–996, Sep. 2006.
- C. Ho, H. Z. Tan, and C. Spence, "The differential effect of vibrotactile and auditory cues on visual spatial attention," *Ergonomics*, vol. 49, no. 7, pp. 724–738, Jun. 2006.
- C. Ho and C. Spence, "Assessing the effectiveness of various auditory cues in capturing a driver's visual attention," *J. Exp. Psychol., Appl.*, vol. 11, no. 3, pp. 157–174, Oct. 2005.

- [36] J. D. Lee, J. D. Hoffman, and E. Hayes, "Collision warning design to mitigate driver distraction," in *Proc. Conf. Hum. Factors Comput. Syst.*, Vienna, Austria, Apr. 2004, pp. 65–72.
- [37] J. B. F. Van Erp and H. Van Veen, "A multi-purpose tactile vest for astronauts in the international space station," in *Proc. Eurohaptics*, Dublin, Ireland, Jul. 2003, pp. 405–408.
- [38] J. B. Van Erp and H. A. Van Veen, "Vibrotactile in-vehicle navigation system," *Transp. Res. F, Traffic Psychol. Behav.*, vol. 7, nos. 4–5, pp. 247–256, Jul. 2004.
- [39] J. B. F. V. Erp, H. A. H. C. V. Veen, C. Jansen, and T. Dobbins, "Waypoint navigation with a vibrotactile waist belt," *ACM Trans. Appl. Perception*, vol. 2, no. 2, pp. 106–117, Apr. 2005.
- [40] G. D. Schott, "Penfield's homunculus: A note on cerebral cartography," *J. Neurol. Neurosurg. Psychiatry*, vol. 56, no. 4, pp. 329–333, Apr. 1993.
- [41] W. Penfield and E. Boldrey, "Somatic motor and sensory representation in the cerebral cortex of man as studied by electrical stimulation," *Brain*, vol. 60, no. 4, pp. 389–443, 1937.
- [42] S. Weinstein, "Intensive and extensive aspects of tactile sensitivity as a function of body part, sex and laterality," in *The Skin Senses*, D. R. Kenshalo, Ed. Springfield, IL, USA: Charles C Thomas, 1968, pp. 195–218.
- [43] V. Harrar and L. R. Harris, "Simultaneity constancy: Detecting events with touch and vision," *Exp. Brain Res.*, vol. 166, nos. 3–4, pp. 465–473, Oct. 2005.
- [44] P. P. Lele, D. C. Sinclair, and G. Weddell, "The reaction time to touch," *J. Physiol.*, vol. 123, no. 1, pp. 187–203, Jan. 1954.
- [45] J. He, A. Chaparro, B. Nguyen, R. Burge, J. Crandall, B. Chaparro, R. Ni, and S. Cao, "Texting while driving: Is speech-based text entry less risky than handheld text entry?" *Accident Anal. Prevention*, vol. 72, pp. 287–295, Nov. 2014.
- [46] S. Cao, Y. Qin, X. Jin, L. Zhao, and M. Shen, "Effect of driving experience on collision avoidance braking: An experimental investigation and computational modelling," *Behav. Inf. Technol.*, vol. 33, no. 9, pp. 929–940, Sep. 2014.
- [47] *Road Vehicles—Transport Information and Control Systems—Detection-Response Task (DRT) for Assessing Attentional Effects of Cognitive Load in Driving*, Standard ISO 17488:2016, International Organization for Standardization, Geneva, Switzerland, 2016.
- [48] S. Castro, J. Cooper, and D. Strayer, "Validating two assessment strategies for visual and cognitive load in a simulated driving task," in *Proc. Hum. Factors Ergonom. Soc. Annu. Meeting*, vol. 60, no. 1. Los Angeles, CA, USA: Sage, 2016, pp. 1899–1903.
- [49] D. L. Strayer, F. A. Drews, and D. J. Crouch, "A comparison of the cell phone driver and the drunk driver," *Hum. Factors*, vol. 48, no. 2, pp. 381–391, Jun. 2006.
- [50] J. He, J. S. Mccarley, and A. F. Kramer, "Lane keeping under cognitive load: Performance changes and mechanisms," *Hum. Factors*, vol. 56, no. 2, pp. 414–426, Mar. 2014.
- [51] F. Mancini, A. Bauleo, J. Cole, F. Lui, C. A. Porro, P. Haggard, and G. D. Iannetti, "Whole-body mapping of spatial acuity for pain and touch," *Ann. Neurol.*, vol. 75, no. 6, pp. 917–924, Jun. 2014.
- [52] D. Kraus, *Concepts in Modern Biology*. New York, NY, USA: Globe Book Company, 1969.
- [53] M. Bergenheim, H. Johansson, B. Granlund, and J. Pederson, "Experimental evidence for a synchronization of sensory information to conscious experience," in *Proc. Toward Sci. Basis Consciousness*, Tucson, AZ, USA, Apr. 1996, pp. 303–310.
- [54] G. A. Gescheider, S. J. Bolanowski, K. L. Hall, K. E. Hoffman, and R. T. Verrillo, "The effects of aging on information-processing channels in the sense of touch: I. Absolute sensitivity," *Somatosensory Motor Res.*, vol. 11, no. 4, pp. 345–357, Jan. 1994.
- [55] C. Spence and C. Ho, "Multisensory warning signals for event perception and safe driving," *Theor. Issues Ergonom. Sci.*, vol. 9, no. 6, pp. 523–554, Nov. 2008.
- [56] H. Alm and L. Nilsson, "The effects of a mobile telephone task on driver behaviour in a car following situation," *Accident Anal. Prevention*, vol. 27, no. 5, pp. 707–715, Oct. 1995.
- [57] C. Spence and C. Ho, "Crossmodal attention: From the laboratory to the real world (and back again)," in *The Handbook of Attention*, J. M. Fawcett, E. F. Risko, and A. Kingstone, Eds. Cambridge, MA, USA: MIT Press, 2015, pp. 119–138.
- [58] W. W. Sutherland, M. F. Levesque, and C. Baumgartner, "Cortical sensory representation of the human hand: Size of finger regions and nonoverlapping digit somatotopy," *Neurology*, vol. 42, no. 5, p. 1020, May 1992.

- [59] C. Ho and C. Spence, "Effectively responding to tactile stimulation: Do homologous cue and effector locations really matter?" *Acta Psychol.*, vol. 151, pp. 32–39, Sep. 2014.



AO ZHU received the bachelor's degree in software technology from the University of Electronic Science and Technology of China. He is currently pursuing the master's degree with Tsinghua University, Beijing, China. His current research interests are primarily focused on driving safety, aviation, and the Internet of Things (IoT) devices. He is developing and promoting detection response task under the guidance of Dr. J. He.



SHI CAO received the Ph.D. degree in industrial and operations engineering from the University of Michigan, Ann Arbor, MI, USA, in 2013. He is currently an Assistant Professor with the Department of Systems Design Engineering, University of Waterloo, Waterloo, ON, Canada. His research interests include human performance and workload modeling, transportation human factors, and human-computer interaction.



HAN YAO is currently a Research Assistant with the Tactile Research Group, Tsinghua University. His research interests include usability, social cognition, and visual cognition.



MURTUZA JADLIWALA (Member, IEEE) received the bachelor's degree in computer engineering from Mumbai University, India, and the Ph.D. degree in computer science from the State University of New York at Buffalo, USA. He is currently an Assistant Professor with the Department of Computer Science, The University of Texas at San Antonio, USA. Prior to that, he was an Assistant Professor with the Department of Electrical Engineering and Computer Science, Wichita State University, USA, from 2012 to 2017, and a Postdoctoral Research Fellow with the Department of Computer and Communication Sciences, Swiss Federal Institute of Technology Lausanne (EPFL), from 2008 to 2011. He also served as a Summer Faculty Fellow for the U.S. Air Force Research Lab - Information Institute in Rome, NY, USA, from June 2015 to August 2015. His current research is focused toward overcoming security and privacy threats in networked computer and cyber-physical systems.



JIBO HE received the bachelor's degree from Peking University, China, and the Ph.D. degree from the University of Illinois at Urbana-Champaign, USA. He is currently an Associate Professor with Tsinghua University, in charge of the international Master of Applied Psychology - User Experience Program. His research interests include human factors, driver distraction, driver fatigue, eye movement, human-machine interaction, visual cognition, attention, computer vision, usability, mobile devices, flight safety, and augmented reality. He develops advanced driving simulator and eye tracking systems.

...