

Received January 13, 2020, accepted January 23, 2020, date of publication January 28, 2020, date of current version February 7, 2020.

Digital Object Identifier 10.1109/ACCESS.2020.2970012

# Enhanced Detection of Epileptic Seizure Using EEG Signals in Combination With Machine Learning Classifiers

WAIL MARDINI<sup>1</sup>, MUNEEB MASADEH BANI YASSEIN<sup>1</sup>, (Member, IEEE),  
RANA AL-RAWASHDEH<sup>1</sup>, SHADI ALJAWARNEH<sup>2</sup>, YASER KHAMAYSEH<sup>1</sup>, AND  
OMAR MEQDADI<sup>2</sup>

<sup>1</sup>Computer Science Department, Jordan University of Science and Technology, Irbid 22110, Jordan

<sup>2</sup>Software Engineering Department, Jordan University of Science and Technology, Irbid 22110, Jordan

Corresponding author: Wail Mardini (mardini@just.edu.jo)

**ABSTRACT** Electroencephalogram (EEG) is one of the most powerful tools that offer valuable information related to different abnormalities in the human brain. One of these abnormalities is the epileptic seizure. A framework is proposed for detecting epileptic seizures from EEG signals recorded from normal and epileptic patients. The suggested approach is designed to classify the abnormal signal from the normal one automatically. This work aims to improve the accuracy of epileptic seizure detection and reduce computational costs. To address this, the proposed framework uses the 54-DWT mother wavelets analysis of EEG signals using the Genetic algorithm (GA) in combination with other four machine learning (ML) classifiers: Support Vector Machine (SVM), K-Nearest Neighbors (KNN), Artificial Neural Network (ANN), and Naive Bayes (NB). The performance of 14 different combinations of two-class epilepsy detection is investigated using these four ML classifiers. The experimental results show that the four classifiers produce comparable results for the derived statistical features from the 54-DWT mother wavelets; however, the ANN classifier achieved the best accuracy in most datasets combinations, and it outperformed the other examined classifiers.

**INDEX TERMS** Electroencephalogram (EEG), discrete wavelet transform (DWT), epilepsy, artificial neural network, k-nearest neighbor (k-NN), support vector machine (SVM), naïve bayes (NB).

## I. INTRODUCTION

Epilepsy is considered as one of the most severe neurological disorders that affect humans' life. Epilepsy can be identified by analyzing the patterns of Electroencephalogram (EEG) signals, which is a popular technique that is used to determine the abnormality of the brain. Hence, EEG signals are widely used by medical doctors and researchers to study epilepsy [1].

Epileptic seizures cause abnormal changes in the brain; therefore, the detection of unpredictable epileptic seizures is implemented traditionally by expert clinicians. The experts usually rely on visual observation of the EEG signals for detecting abnormalities. This process is typically time-consuming and prone to human errors. Therefore, automatic diagnosis of epileptic seizures is essential in the clinical environment, and there is a need for improving the automated

classification techniques that evaluate and assess the EEG signals. In this paper, the proposed approach automatically performs an initial assessment of the patients' signs as to whether their corresponding EEG signals indicate the presence of seizure or not without human intervention.

One of the most techniques that are used for detecting the epileptic seizure is pattern recognition, where the hidden patterns are extracted from EEG. Researchers have attempted different features extraction methods to extract the hidden patterns from EEG signals such as DWT, CWT, FT, DFT, IDFT, STFT, and FFT [2]–[6]. Moreover, different techniques such as Particle Swarm Optimization (PSO), Simulated Annealing (SA), Ant Colony Optimization (ACO) [7], and many other schemes to select the best features were investigated. In term of the classification methods, various classifiers were examined by the researchers namely support vector machines, decision tree, artificial neural network, k-nearest neighbors (k-NN), naïve Bayes (NB), Gaussian mixture

The associate editor coordinating the review of this manuscript and approving it for publication was Juan A. Lara.

model, adaptive neuro-fuzzy inference systems, and learning vector quantization to identify epileptic seizures from the EEG signals. All the patterns mentioned above recognition approaches focus on increasing the accuracy of detecting epileptic seizures with different combinations of features extraction, selection, and classification techniques [8]–[11].

In this paper, we aim to improve the detection accuracy for fourteen different combinations of datasets using 54 DWT mother wavelets to extract a set of features. These features include Mean Absolute Value (MAV), Average Power (AVP), Standard Deviation (SD), Variance, Mean, Skewness, Shannon Entropy, Max, Min, Normalized SD, Kurtosis, and Energy [12]–[16]. The number of the derived features are then minimized using the genetic algorithm (GA) to select the most relevant features. Finally, the selected characteristics are studied using four classifiers to identify the output as an epileptic seizure or not.

The rest of this paper is organized as follows: Section II presents the related work, Section III introduces the proposed feature selection methodology. The classification setup and experiments are discussed in Section IV. Section V and VI discuss the evaluation methodology and the numerical results, respectively. Finally, Section VII contains conclusions and future work.

## II. RELATED WORK

Many researchers have paid attention to EEG signals classification for epilepsy detection. In this section, we review a set of recent related works to epileptic seizure detection from EEG signals.

The authors in [17] proposed a new approach based on the 54- DWT mother wavelets divided into seven families to divide the EEG data into different sub-bands to extract the statistical features. Then, an SVM classifier is used to categorize the EEG signals based on the extracted features. The experimental results display that the accuracy is mainly sensitive to the level of decomposition, and 40% of the redundancies were removed from the resulting features.

The authors in [18] primarily rely on an analysis of EEG signals by making use of discrete wavelet transforms (DWT) to decompose the EEG data into different sub-bands, and then extract the statistical features. The derived statistical features from DWT are used to train the classifier. After that, two classifiers are used to determine the signals if they have epileptic or not. The two classifiers are KNN and Naive Bayes classifiers [18]. This research measures the performance of the 14 numerous combinations of two-class epilepsy detection. The experimental consequences defined that, for the detection of epileptic seizure abnormality, the NB classifier achieves higher accuracy for most combinations of the dataset with less computation time, and the other classifier attains better accuracy for just 4 data sets combination.

The authors in [19] presented in their research an outline of the definition of epileptic seizure prognosis with the aid of way of making use of Hurst Exponent (HE) that

primarily based on discrete wavelet for features functions extraction from EEG records. These features are gained through the ictal and pre-ictal stages of affected patients. The categorizing process of EEG indicators was applied using SVM and KNN Classifiers. In their research, the HE is defined to differentiate the EEG signals in terms of the more potent relative consistency, and less dependence on data length. The main consequences that appeared from this research are; the DWT-primarily based non-linear features coupled with SVM have given vital effects. The HE values, which are calculated to measure the regularity or predictability of EEG signal drops during seizure interval, and the SVM classifier give the highest accuracy, reach up to 99%.

In [20], the authors used a wavelet transform and Support Vector Machine (SVM) classifier to identify seizure to identify the rate of seizure in a patient from the EEG signals. They also aim to avoid aggressive situations during a patient seizure. They use seven levels of decomposition to obtain subbands. Narrow subbands used to detect the seizure and the other two subbands used for extracting the statistical features and then for the classification of EEG signal using an SVM classifier. A normal EEG dataset and a seizure dataset during a seizure period have been used. The classification accuracy is 95.6%.

The authors in [21] used recorded EEG signals for a healthy and epileptic patient to develop a new framework used for the detection of an epileptic seizure. The simulation tool used Simulink. The statistical feature extracted for epilepsy detection with k-Nearest Neighbor (k-NN) classifier is: Mean Absolute Value (MA), Standard Deviation (SD), and Average Power (AP). The result shows that the best results were achieved using k-NN classifier with SD and SD with MA for eyes open and epileptic seizure dataset with less number of extracted features.

A novel automated detection system was developed in [22] to distinguish between intracranial EEG time courses with seizures and the seizure-free ones based on complexity measures. An estimate of multiscaling properties with a large spectrum measured by using the generalized Hurst exponent to characterize the EEG signals. These estimates were able to correctly (100%) classify the seizure intervals tested on a given data set and using the k-nearest neighbor classifier and with tenfold cross-validation.

The authors on [23] aim to improve the treatment and diagnosis of medically refractory epilepsy patients. Using directed transfer function (DTF), they developed a new algorithm for epileptic seizure detection. The authors used the sliding window technique for EEG recording segmentation. The DTF algorithm used to calculate cerebral functional connectivity. Then, the total information outflow based on the DTF-derived connectivity was calculated by adding up the information flow from a single EEG channel to other channels. Finally, the information outflow was assigned as the features of the support vector machine (SVM) classifier to discriminate interictal and ictal EEG segments. The mean

accuracy rate achieved was 98.45%, with an excellent percentage for the other related metrics.

For features extraction and classification of EEG signals, a reference model is introduced in [33] that identifies a region of interests from the set of time series. These regions (also known as events) encodes the most relevant information for the classification task, hence, no need to process the whole time series. Then, the time-frequency analysis is conducted using a Discrete Wavelet Transform (DWT). Finally, the Adaptive Fuzzy Inference Neural Network System is used for the classification.

A two-phase system was proposed in [34]. In the first phase (pre-processing phase), a wavelet transformation is used to extract essential features from the EEG signals. A learning-based technique is then applied in phase 2 to classify the extracted features into the correct classes. Due to the large complexity of the extracted features, multiple sub-classifiers were combined together to perform the classification task. Each sub-classifier is an “expert” subdomain. The authors in [34] used 2 alternatives for the classification phase: Multi-layer Perceptron Network (MLP), and Radial Basis Function Network (RBF).

In the following, we discuss the four classifiers that are used in this study

#### A. SUPPORT VECTOR MACHINE (SVM)

SVM algorithm is a binary classification technique. It has many characteristics, such as a robust to a very massive variety of variables and small samples, and can deal with massive predictors [29], [30]. SVM generally look for finding the best hyper-plan that separates all data points of one class from those of the other classes. The best hyper-plane means the one with the most significant margin between the two classes. Margin means the maximal width of the slab parallel to the hyperplane that has no interior data points. In SVM, the linear decision surface is founded to be able to isolate the patient’s classes, and it owns the most noticeable gap among borderline patients.

#### B. NAIVE BAYES (NB) CLASSIFIER

The NB algorithm deals with features and classes. It is considering a fast algorithm that examines all its training datasets, and it requires less data for classification. NB is a probabilistic classifier, which is based totally on the learning by taking into consideration that the features are independent given the class (Bayesian theory), where each feature of a particular class is independent of other features. Independence usually is a terrible assumption. This algorithm based on the Bayesian theorem. For each instance, the relationship among each attribute and the class are analyzed in this classifier, to derive a conditional probability for these relationships.

#### C. K- NEAREST NEIGHBORS (KNN)

K-NN is considered a nonparametric, nonlinear, and simple technique that is used to classify the samples [31], [32]. It works well for the larger training dataset. In this algorithm,

the classification of the data object is performed by calculating the majority vote of neighbors, and the object will obtain the class that most common among its k-nearest neighbors. It is based mainly on similarity measures such as Euclidean distance, Manhattan distance, and other between the training and test data sets. The new samples are assigned to the class based on nearby k datasets for training based on similarity measures, so the majority vote of the case neighbors is calculated to categorize the case. The best value for K is between 3 and 10. That produces awful lot higher results than 1.

#### D. ARTIFICIAL NEURAL NETWORK (ANN)

ANN is a function comprised of neurons and weights. The neurons pass the input values through functions and output the results, while the weights carry the values between neurons. The neurons can be classified into three main layers; input layers, hidden layers, and output layers. The input layer contains various input units; the main purpose of the input layer is to represent the information to be fed into the network. The hidden layers contain the hidden units that are based on two factors: the first one is the input units’ activities, and the second one is the weights that are founded on the connections among the input and the hidden units.

### III. THE PROPOSED APPROACH AND METHODOLOGY

The proposed method uses 54-DWT mother wavelets, Genetic algorithm, and four classifiers to classify the EEG signals for epilepsy seizure detection. Figure 1 shows the flow of the proposed methodology.

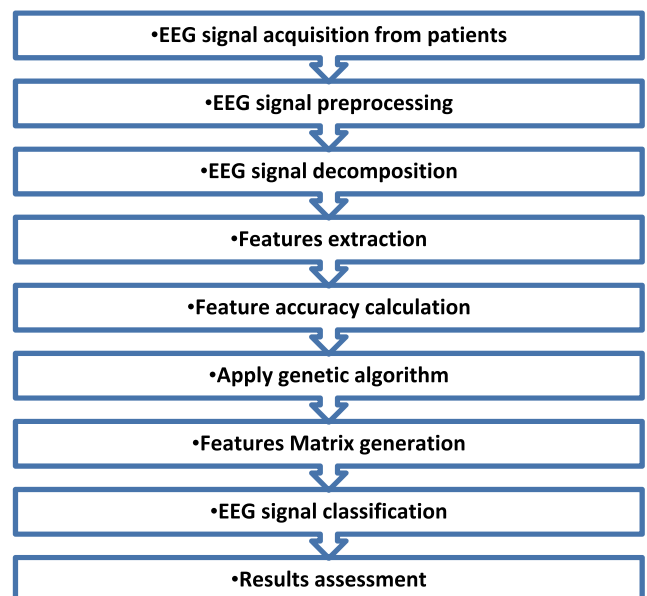

FIGURE 1. Block diagram of proposed methodology.

We acquire publicly accessible EEG data from Bonn University, wherein the data include five sets (A, B, C, D, and E). Each set consists of 100 single EEG segments with a sampling rate of 173.6 HZ. The EEG signals were filtered using a Bandpass filter and smoothing method. The first two sets (A, B) represent healthy people, whose signals were taken

TABLE 1. DWT wavelets families.

Wavelet family	Mother wavelet	No. of features
<b>Biorthogonal</b> (Family 1)	bior1.1, bior1.3, bior1.5, bior2.2, bior2.2, bior2.4, bior2.6, bior2.8, bior3.1, bior3.3, bior3.7, bior3.9, bior4.4, bior5.5, bior6.8	1692
<b>Coiflets</b> (Family 2)	coif1, coif2, coif3, coif4, coif5	516
<b>Daubechies</b> (Family 3)	db1,db2,db3,db4,db5,db6,db7,db8,db9,db10	1152
<b>Reverse biorthogonal</b> (Family 4)	rbior1.1, rbior1.3, rbior1.5, rbior2.2, rbior2.2, rbior2.4, rbior2.6, rbior2.8, rbior3.1, rbior3.3, rbior3.7, rbior3.9, rbior4.4, rbior5.5, rbior6.8	1692
<b>Symlets</b> (Family 5)	sym2,sym3,sym4,sym5,sym6,sym7,sym8	804
<b>Discrete Meyer</b> (Family 6)	demy	72
<b>Haar</b> (Family 7)	haar	156

with open and closed eyes. The other three sets represent epileptic persons. Sets (C, D) were treated as non-seizure because the signals are captured in duration without seizures. For seizure detection, set (E) was only treated as an epileptic seizure.

The primary purpose of the preprocessing stage is to increase and improve the system performance by isolating the noises from the EEG signals [24]. So, we use the Bandpass filter and smoothing method to remove the noises [25].

The feature extraction stage aims to extract the statistical features from the EEG signals [17]. Our method focuses mainly on using 54-DWT mother wavelets. These 54-DWT mother wavelets are divided into seven families. Table 1 shows the 54 DWT mother wavelets and their families.

DWT follows the following methodology for extracting the statistical features:

- The signal is passed through the high and low pass filters to generate the approximation and detailed coefficients.
- The Nyquist rule is applied, so the frequency of the resulted signals from the previous step has half of the original signal' frequency bandwidth.
- The outputs of the low pass filter are passed to the filters in the next level, and the same process is repeated to get the detailed and approximation coefficients.
- For each step, the frequency resolution is increased, and the time resolution is decreased.

- In this study, each 54-DWT mother wavelets decompose the signal  $x[n]$  into different sub-bands (levels). For each level, the signal passes through the high pass filter  $h[n]$  and low pass filters  $g[n]$  to create the approximation (A) and detailed (D) coefficients.

After that, the statistical features are applied for the detailed coefficients. In the next step, the outputs (coefficients) of the low pass filter  $g[n]$  are passed to the high and low pass filters in the next level; for each step, the frequency resolution is increased, and the time resolution is decreased. The same process is repeated until we reach a high level of decomposition for each DWT wavelet.

The feature matrix is a way to represent the signal, and it is represented when the wavelet coefficients have been produced. The approximation coefficients and detailed coefficients were utilized to form the shape of the feature's matrix. These coefficients constitute the range between 0.05 -86 Hz of frequency bands.

In this study, we use the following features that are derived from the detailed coefficients of the DWT using the following mathematical equations.

1. Mean Absolute Value (MAV) =  $\frac{1}{s} \sum_{i=1}^s |x_i|$
2. Average Power (AVP) =  $\frac{1}{s} \sum_{i=1}^s |x_i|^2$
3. Standard Deviation (SD) =  $\sqrt{\frac{1}{s-1} \sum_{i=1}^s (x_i - u)^2}$
4. Variance =  $\frac{1}{s-1} \sum_{i=1}^s (x_i - u)^2$
5. Mean =  $\frac{1}{s} \sum_{i=1}^s x_i$
6. Skewness =  $\frac{1}{s \cdot SD^3} \sum_{i=1}^s (y_i - y)^3$
7. Shannon Entropy (ShEnt) =  $-c \sum_{i=1}^s P(x_i) \log_2 P_i$
8. Max: measure the maximum wavelet coefficients in each sub-band.
9. Min: measure the minimum wavelet coefficients in each sub-band
10. Normalized SD =  $\frac{std\_coeff}{\max\_coeff - \min\_coeff}$
11. Energy:  $Energy(E_i) = \sum_{j=1}^N D_{ij}^2$

The first five features and feature eight and nine are standard statistical features in statistics. Skewness is a measure for the asymmetry in a statistical distribution, in which the curve appears distorted or skewed either to the left or to the right. Shannon entropy measures the level of the chaos of the system. Normalized SD aims to represent the standard deviation with 0-1 range. Each chromosome has a value or cost that represents the energy of this chromosome which is computed in feature eleven.

The features selection and reduction stage aim to reduce the dimensions of the features and choose the most suitable features. In this study, we applied the genetic algorithm (GA). GA is a method of problem-solving, mainly optimization problems [26]. It based on natural evolution by natural selection and inheritance. It benefits from the evolutionary principle of survival, the best-adapted individuals. In a genetic algorithm, we adopted the following steps to select the best features from DWT wavelets mothers:

### Genetic Algorithm Parameters

Number of individuals in the population: 7  
 Type of gene representation: floating point vectors  
 Chromosomes construction of individuals: floating point vectors of the form [g1, g2, g3, g4, ..... f72]  
 Initial population: uniform  
 Target value of fitness function: 00  
 Maximum Number of generation: 100  
 Fitness Function is calculated according to Euclidean distance.

## IV. EEG SIGNALS CLASSIFICATION

The final step of our proposed approach is to classify the EEG signals. So, the statistical features that are reduced using Genetic Algorithm (GA) are applied to the classifiers [27], [28].

The classifiers are applied to learn the class category of the unknown samples from the known samples. We adopted four classifiers; these classifiers include SVM, ANN, KNN, and Naive Bayes. The performances of the classifiers are assessed with accuracy, specificity, and sensitivity.

## V. EVALUATION

Different evaluation metrics were measured in this thesis to evaluate the performance of our proposed model. The evaluation metrics are Accuracy, Sensitivity, and Specificity. The evaluation metrics are measured using the k-fold cross-validation and holdout test model [16]; after that, the results will be compared. First, we define the following elements:

- True positive (TP): is an outcome where the model correctly predicts the positive class.
- True negative (TN): is an outcome where the model correctly predicts the negative class.
- False-positive (FP): is an outcome where the model incorrectly predicts the positive class.
- False Negative (FN): is an outcome where the model incorrectly predicts the negative class.

Then we measure accuracy, sensitivity, and specificity as follow:

- Accuracy
  - It measures the number of correctly classified samples / total number of samples. Furthermore, it can be represented according to the following formula.
  - $Accuracy = \frac{TP+TN}{TP+TN+FP+FN}$
- Sensitivity (TPR)
  - It measures the number of truly discovered positive samples / all number of actual positive samples, and it can be represented according to the following formula.
  - $Sensitivity = \frac{TP}{TP+FN}$
- Specificity (TNR)
  - It measures the number of correctly detected negative samples/ total number of actual negative

samples. It can be represented according to the following formula.

$$\circ Specificity = \frac{TN}{TN+FP}$$

## VI. RESULTS AND DISCUSSION

The results presented here represent the accuracy, specificity, and sensitivity of 14 dataset 'combinations, these results represent the evaluation metrics, that are generated after applying the genetic algorithm. The samples in the native data are randomly divided into testing and training datasets: 70% for training, and 30% for testing.

In this paper, 14 classification combinations (training- testing): (A-E), (B-E), (C-E), (D-E), (AB-E), (AC-E), (AD-E), (BC-E), (CD-E), (ABC-E), (ACD-E), (BCD-E), and (ABCD-E). In all combinations, we used the dataset E as it is the only one treated as an epileptic seizure. These combinations are used to identify the epileptic signal from a normal signal. In this study, we conducted a comparison between classifiers for the identification of the epileptic signal. The purpose of this study is to enhance the detection of abnormality accuracy from EEG data. The performance of the four classifiers is studied with equal training and testing data sets.

Table 2 shows the performance of four classifiers for the selected features from the genetic algorithm according to the accuracy obtained from the SVM classifier. The accuracy was as high as possible in case1, case2, and case5, where it reached 100%. The worst accuracy was gained by cases 6, case 8, and case10, where their accuracy ranges between 93.3% and 94.4%. The table shows that the accuracy of the remaining cases ranges between 95% and 98.8%. In NB classifier, the accuracy for the 14 combinations of shows that the Naive Bayes algorithm obtained the best results in first two cases, where the accuracy reaches up to 100%, but in the following cases 3, 6, 8, the accuracy was low as possible where they did not exceed 95%. However, in these cases, the accuracy was minimal, because the features vector resulting from these cases in the features extraction stage are less accurate than the rest of the cases according to the Euclidean distance. The accuracy in the remaining cases ranges between 97.7% and 99.3% in terms of accuracy using the ANN classifier. The accuracy was the best in case1, case2, and case5, due to the high accuracy of the features matrix that appeared to form these combinations, where the accuracy reaches up to 100%, as shown in the table. The results show that the following cases: case3 and case10 showed less accuracy than the rest of the cases. Like the other cases, the accuracy ranges from 96.6% to 98.8%. In KNN classifier, the accuracy reaches to 100% in four cases, which are case1, case2, case4, case5, the main reason behind this results is the combination of features that resulted from genetic algorithm have the highest accuracy, while the accuracy in both case6 and case 8 did not exceed 95%, due to the low accuracy of the set of features that train this classifier. The Sensitivity for the same 14 combinations of the dataset by using the NB classifier. The table shows that the Naive Bayes algorithm obtained 100% in case2 and case5, but in the case 6, the sensitivity was minimal, because

**TABLE 2. Results of accuracy, sensitivity, and specificity for the different cases (all values percentages).**

Datasets		SVM	NB	ANN	KNN
A-E Case 1	Accuracy	100	100	100	100
	Sensitivity	100	100	100	100
	Specificity	100	100	100	100
B-E Case 2	Accuracy	100	100	100	100
	Sensitivity	100	100	100	100
	Specificity	100	100	100	100
CE Case 3	Accuracy	95	95	95	96.6
	Sensitivity	100	96.5	100	100
	Specificity	90.9	93.5	90.9	93.7
DE Case 4	Accuracy	98.3	98.3	98.3	100
	Sensitivity	100	96.7	100	100
	Specificity	96.6	100	96.7	100
AB-E Case 5	Accuracy	100	98.9	100	100
	Sensitivity	100	100	100	100
	Specificity	100	97.1	100	100
AC-E Case 6	Accuracy	93.3	93.3	96.6	94.4
	Sensitivity	96.2	94.6	100	96.3
	Specificity	88.8	91.1	91.8	91.4
AD-E Case 7	Accuracy	98.8	98.8	98.8	98.8
	Sensitivity	100	98.2	100	100
	Specificity	97.1	100	97.1	97.1
BC-E Case 8	Accuracy	94.4	93.3	96.6	94.4
	Sensitivity	98.1	96.2	100	96.3
	Specificity	89.1	88	91.8	91.4
BD-E Case 9	Accuracy	98.8	98.8	98.8	98.8
	Sensitivity	100	98.1	100	100
	Specificity	97.1	91.4	97.1	97.1
CD-E Case 10	Accuracy	94.4	94.4	94.4	95.5
	Sensitivity	98.1	98.1	98.1	98.1
	Specificity	89.1	89.1	89.1	91.6
ABC-E Case 11	Accuracy	95.8	97.5	97.5	95.8
	Sensitivity	95.7	97.8	96.8	96.7
	Specificity	96.1	96.4	100	92.8
ACD-E Case 12	Accuracy	95	97.5	97.5	95.8
	Sensitivity	94.7	97.8	96.7	96.7
	Specificity	96	96.4	96.2	92.8
BCD-E Case 13	Accuracy	98.3	97.5	98.3	97.5
	Sensitivity	98.8	98.8	97.8	97.8
	Specificity	96.5	93.3	100	96.4
ABCD-E Case 14	Accuracy	98	99.3	98.6	98.6
	Sensitivity	97.5	99.1	98.3	98.3
	Specificity	100	100	100	100

the features resulting from this combination are less strong than the rest of cases according to the Euclidean distance metric, and the sensitivity in remaining cases ranges between 96.2% and 99.1%. According to the NB specificity metric, we obtain 100% in four cases, and we obtain specificity equal to 88% and 89% in case 8 and case 10, which form the worst cases.

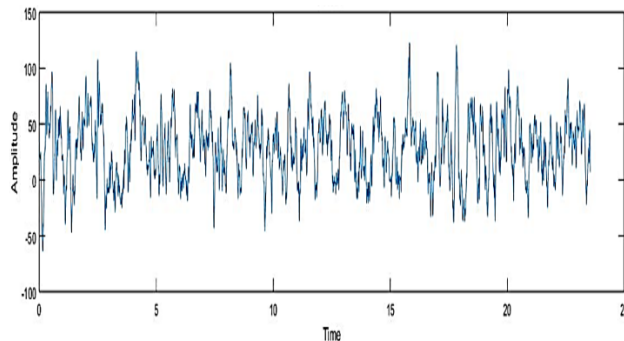

**FIGURE 2. Normal EEG signal before preprocessing.**

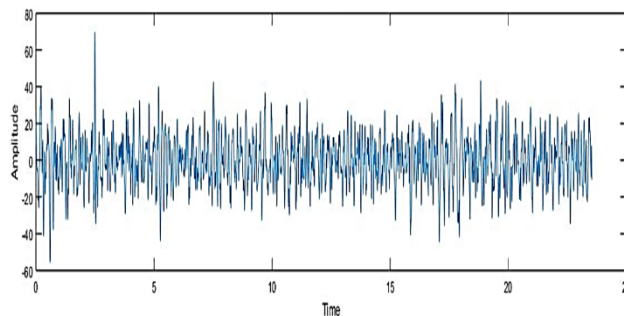

**FIGURE 3. Normal signal after preprocessing.**

According to the SVM sensitivity metric, the results show that the classifier has 100% in 7 cases, and the worst cases appear in case 11 and case 12 that ranges between (95.7% and 94.7%). The results of the specificity metric, according to SVM, show that the classifier has 4 cases with 100%, and 3 cases with specificity range between 88.8% and 89.1% that form the worst cases. The sensitivity of the ANN 14 combination of the dataset, the sensitivity reaches 100% for the first 9 cases, and the remaining cases presented results range between 96.7 and 98.3. According to the ANN specificity metric, the classifier obtains 6 cases with 100%, and the worst case was case 10 with accuracy equal to 89.1%. The KNN sensitivity of the same combination of datasets shows that the first 5 cases, case 7, and case 9 obtained a sensitivity reach to 100 %, while case 6 and 8 the accuracy was as low as possible and reached to 96.3%. According to the KNN specificity metric, the classifier obtains 100% in 5 cases, but the accuracy of case 6, case 8, case 10 did not exceed 92.8%.

Figure 8, 9 and 10 below show the evaluation metrics that were used to compare the classifier’s behaviors. These metrics are average accuracy, average sensitivity, and average specificity. These metrics are obtained from computing the average accuracy, sensitivity, and specificity for all 14 cases of the datasets. The artificial neural network (ANN) classifier has obtained the best average accuracy, average sensitivity, and average specificity compared to other classifiers. The Artificial Neural Network classifier will form our approach, and it will be compared to other classifiers according to the average accuracy, average sensitivity, and average specificity. The average accuracy in Figure 8 which shows that the ANN classifier outperformed other classifiers, and its accuracy reaches 97.82%, while Figure 9 displays the average

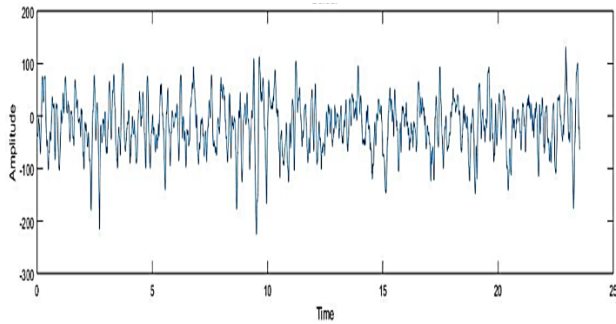

FIGURE 4. Abnormal signal before preprocessing.

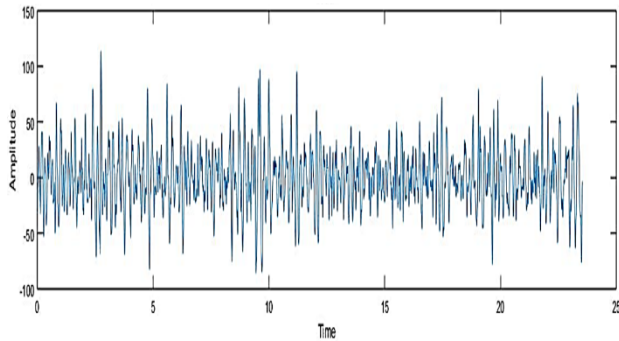

FIGURE 5. Abnormal signal after preprocessing.

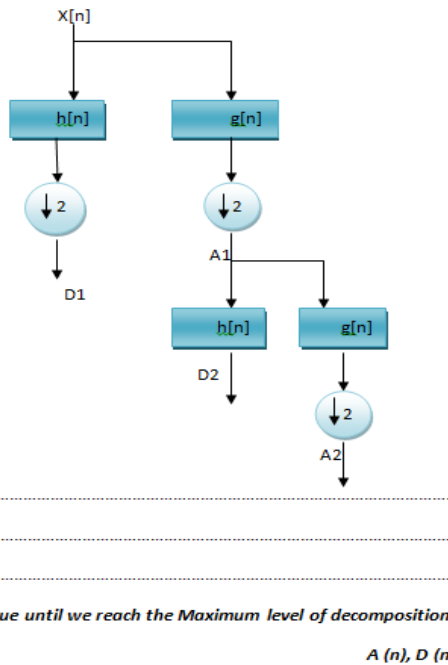

FIGURE 6. Maximum level wavelet decomposition of EEG signals.

Sensitivity of the proposed classifiers, and it shows that the ANN classifiers obtained the highest value compared to other classifiers. Figure 10 displays the average Sensitivity of the ANN classifier and explains that the ANN was the best classifier, and it reaches 99.12%.

In Figures 11, 12, and 13 we compare our work with three previous studies, which have the same combinations. We present the previous methods that use the same datasets and similar cases, and we compare our methods and the

Genetic Algorithm
<b>Input:</b> Training Data
<b>Output:</b> Extracted features
<b>Step 0:</b> Set GA parameters
<b>Step 1:</b> Generate population By grouping the features into 7 families
<b>Step 2:</b> Calculate the fitness function
<b>Step 3:</b> While (termination condition) [4-8]
3.1 Selection
3.2 Crossover
3.3 Mutation
3.4 Fitness function evaluation

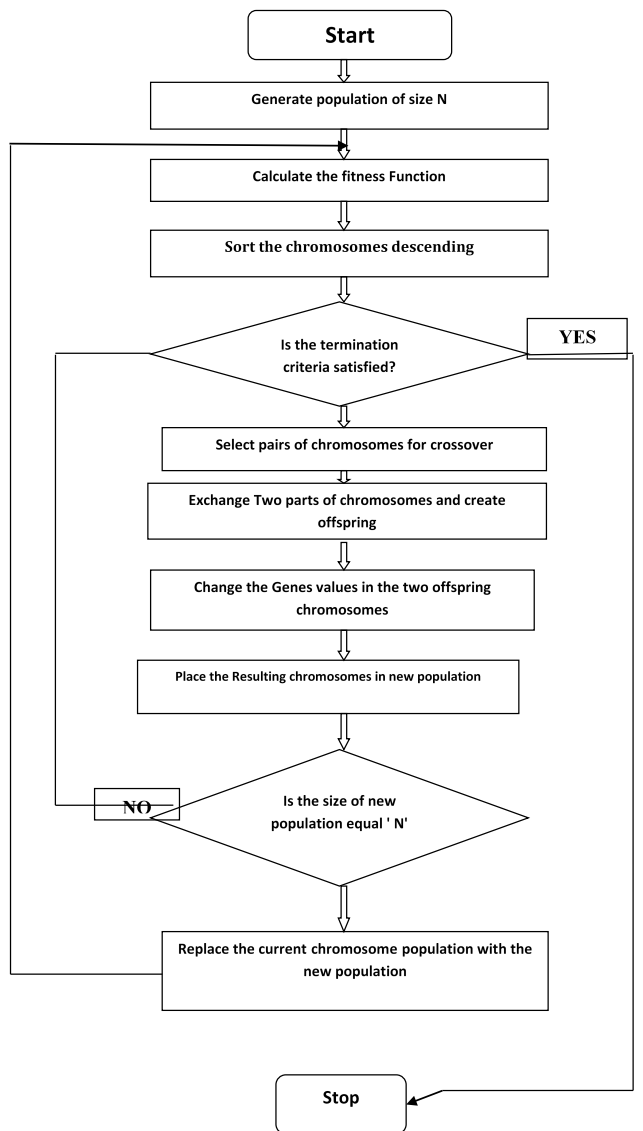

FIGURE 7. Genetic Algorithm pseudo-code and flow chart.

previous methods to make the results more realistic. According to the results below, our methods outperform the previous methods in most cases for all evaluation metrics.

Figure 11 shows that our approach by using Artificial Neural Network outperforms the previous approaches according to the average accuracy, where the average accuracy reaches

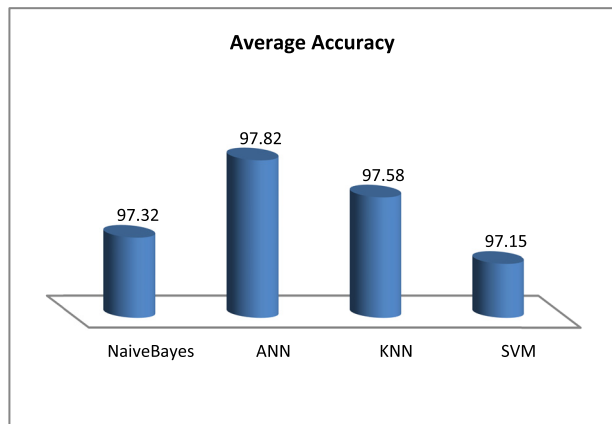

FIGURE 8. The average accuracy of classifiers.

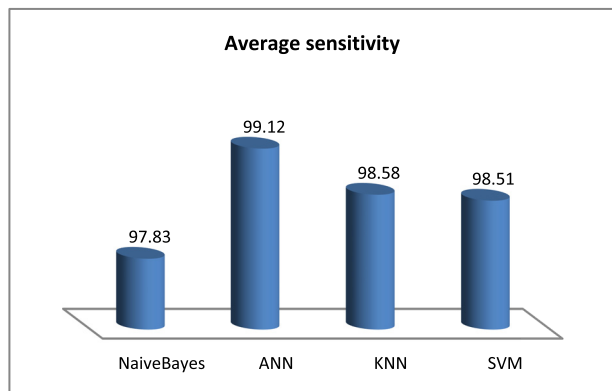

FIGURE 9. The average sensitivity of classifiers.

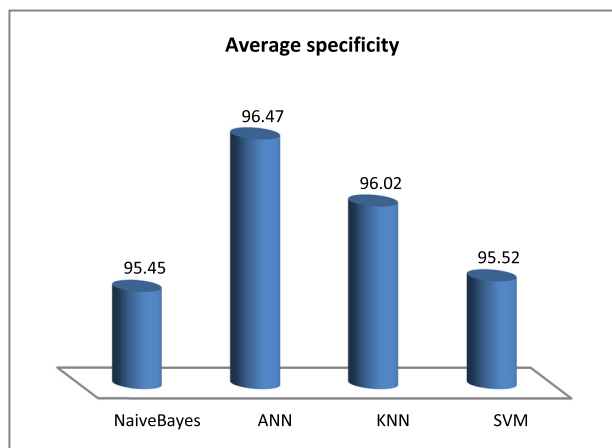

FIGURE 10. The average specificity of classifiers.

97.9%, and it achieved comparable results. In terms of the NB classifier, the previous study outperforms our work, where it achieves average accuracy reach to 97.8%, but in our work, we achieve comparable results reach 97.3%. According to KNN and SVM classifiers, we achieve the highest average accuracy with improvement equal to 2.3% by using KNN classifier, while we obtain 2.6% by using SVM classifier, where we obtain average accuracy equal to 97.1% and 97.9% respectively in our work.

Figure 12 shows the average sensitivity between our methods compared with the previous studies, in term of

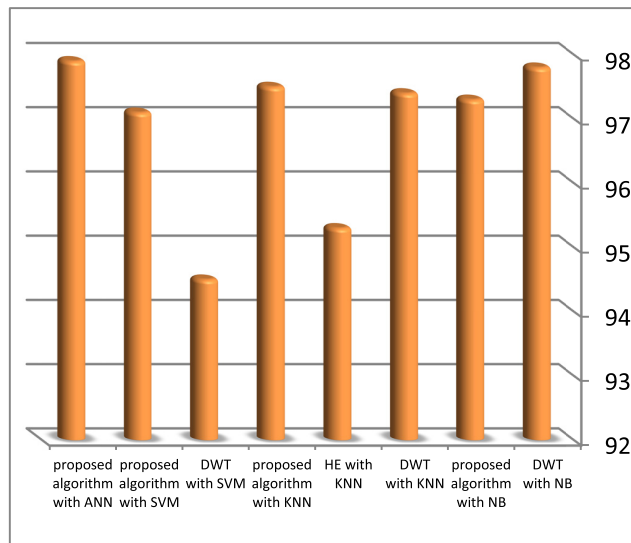

FIGURE 11. Average Accuracy compared to previous studies.

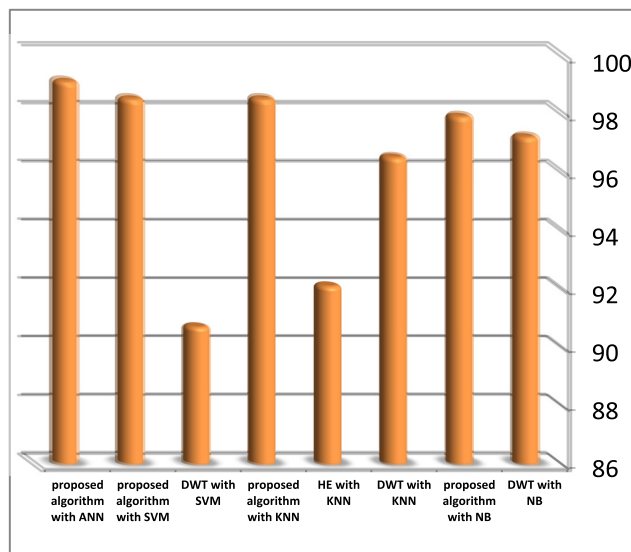

FIGURE 12. Average sensitivity compared to previous studies.

NB classifier, our work outperforms the previous study with improvement equal to 0.7%. According to KNN, our work outperforms the previous works with improvements equal to 2% and 6.4%, respectively. In the SVM classifier, we achieve the most significant improvement, equal to 7.8%. By using ANN classifier, the highest average sensitivity was achieved, where the average sensitivity reaches to 99.1%

Figure 13 shows the average specificity of our work compared to the previous study. The Figure shows the previous studies outperform our work. In terms of the NB classifier, the previous work obtains 98.4%, while our work obtains 95.4%. In the KNN classifier, our work achieved 96%, while the previous study obtains 98%. In terms of SVM and ANN, we obtain an average specificity equal to 95.5% and 96.5%, respectively.



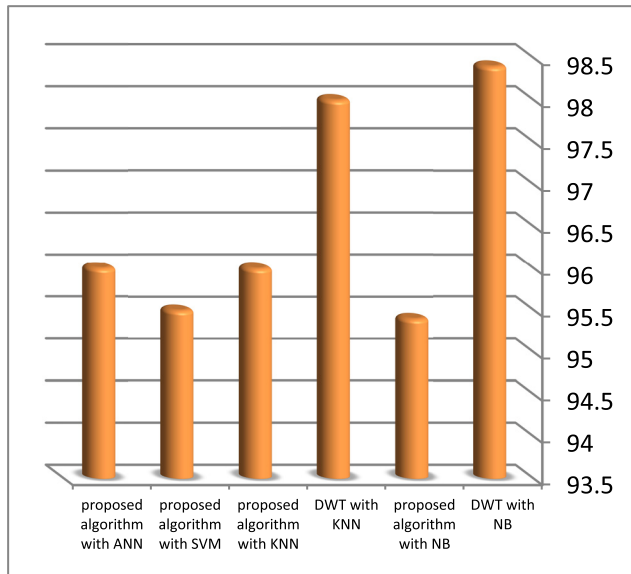

FIGURE 13. Average Specificity compared to previous studies.

## VII. CONCLUSIONS AND FUTURE WORK

Epilepsy is one of the most diseases that affect human lives, so they need to diagnose; it is one of the lives needed. The diagnosis process is not a simple task. In this work, we propose a novel approach to diagnosis the EEG signals using Multi-DWT, and Genetic algorithm coupled with four classifiers such as SVM, ANN, KNN, and Naive Bayes. The experimental results showed that the DWT features coupled with some machine learning algorithms had provided noticeable results, and the ANN classifier outperforms all tested classifiers. The new automated system can detect epilepsy with high accuracy. The detection process of epilepsy seizure passes through different stages. The first step is the pre-processing of the EEG signals that are considered the primary step, which will increase the system performance. This step aims to remove the noises. The second step features extraction. This step is previously implemented with different methods; in this work, we apply multiple DWT. The main aim of this step is to decompose the signals into sub-bands, then compute different features functions on each sub-band. In our work, we use multiple DWT to extract various features, and then these features are reduced by the genetic algorithm to select the best features from a vast number of features. The output of this stage is a features matrix that will be used later in EEG signals classification. In EEG signals classification, the decision is made, and the system performance will be evaluated. The success of the suggested approach is verified by implementing the same procedure for 14 combinations of datasets. The proposed system was tested under different measurement metrics such as Accuracy, Sensitivity, and Specificity.

The results showed that our approach achieved good results in terms of these metrics, and it can be concluded that DWT analysis give satisfactory results compared with the previous studies, and the best performance was gained by artificial neural network classifier. The ANN was compared with the

different classifiers, and it performs better in terms of the evaluation metrics in most cases of 14 dataset combinations.

For future work, we propose to investigate the usage of state-of-the-art deep learning networks to overcome the limitations of classical learning models. Classical learning models are sensitive to the feature selection and extraction phases. Moreover, we propose to investigate the effect of the given dataset on the classification results. For this, we propose to examine different datasets from different regions of the world.

## REFERENCES

- [1] L. Hussain, W. Aziz, A. S. Khan, A. Q. Abbasi, and S. Z. Hassan, "Classification of electroencephalography (EEG) alcoholic and control subjects using machine learning ensemble methods," *J. Multidiscip. Eng. Sci. Technol.*, vol. 2, no. 1, pp. 126–131, Jan. 2015.
- [2] A. Hamad, E. H. Houssein, A. E. Hassanien, and A. A. Fahmy, "Feature extraction of epilepsy EEG using discrete wavelet transform," in *Proc. 12th Int. Comput. Eng. Conf. (ICENCO)*, Dec. 2016, pp. 190–195.
- [3] U. R. Acharya, S. Vinitha Sree, G. Swapna, R. J. Martis, and J. S. Suri, "Automated EEG analysis of epilepsy: A review," *Knowl.-Based Syst.*, vol. 45, pp. 147–165, Jun. 2013.
- [4] P. Sarma, P. Tripathi, M. P. Sarma, and K. K. Sarma, "Pre-processing and feature extraction techniques for EEGBCI applications—a review of recent research," *ADBU J. Eng. Technol.*, vol. 5, no. 1, pp. 1–8, 2016.
- [5] C. Umale, A. Vaidya, S. Shirude, and A. Raut, "Feature extraction techniques and classification algorithms for EEG signals to detect human stress—a review," *Int. J. Comput. Appl. Technol. Res.*, vol. 5, no. 1, pp. 8–14, Jan. 2016.
- [6] K. Polat and S. Güneş, "Artificial immune recognition system with fuzzy resource allocation mechanism classifier, principal component analysis and FFT method based new hybrid automated identification system for classification of EEG signals," *Expert Syst. Appl.*, vol. 34, no. 3, pp. 2039–2048, Apr. 2008.
- [7] O. Salem, A. Naseem, and A. Mehaoua, "Epileptic seizure detection from eeg signal using discrete wavelet transform and ant colony classifier," in *Proc. IEEE Int. Conf. Commun. (ICC)*, Jun. 2014, pp. 3529–3534.
- [8] S. A. Aljawarneh, V. Radhakrishna, and A. Cheruvu, "VRKSHA: A novel tree structure for time-profiled temporal association mining," in *Neural Computing and Applications*. Cham, Switzerland: Springer, 2017, pp. 1–29. [Online]. Available: <https://link.springer.com/article/10.1007%2Fs00521-018-3776-7>
- [9] S. A. Aljawarneh, R. Vangipuram, V. K. Puligadda, and J. Vinjamuri, "G-SPAMINE: An approach to discover temporal association patterns and trends in Internet of Things," *Future Gener. Comput. Syst.*, vol. 74, pp. 430–443, Sep. 2017.
- [10] V. Radhakrishna, S. A. Aljawarneh, P. Veereswara Kumar, and V. Janaki, "ASTRA—A novel interest measure for unearthing latent temporal associations and trends through extending basic Gaussian membership function," *Multimedia Tools Appl.*, vol. 78, no. 4, pp. 4217–4265, Feb. 2019.
- [11] V. Radhakrishna, S. A. Aljawarneh, V. Janaki, and P. Kumar, "Looking into the possibility for designing normal distribution based dissimilarity measure to discover time profiled association patterns," in *Proc. Int. Conf. Eng. MIS (ICEMIS)*, May 2017, pp. 1–5.
- [12] S. M. Akareddy and P. K. Kulkarni, "EEG signal classification for epilepsy seizure detection using improved approximate entropy," *Int. J. Public Health Sci.*, vol. 2, no. 1, pp. 23–32, Feb. 2013.
- [13] A. Baldominos and C. Ramon-Lozano, "Optimizing EEG energy-based seizure detection using genetic algorithms," in *Proc. IEEE Congr. Evol. Comput. (CEC)*, Jun. 2017, pp. 2338–2345.
- [14] N. Williams, S. Zander, and G. Armitage, "A preliminary performance comparison of five machine learning algorithms for practical IP traffic flow classification," *ACM SIGCOMM Comput. Commun. Rev.*, vol. 36, no. 5, pp. 5–16, 2006.
- [15] L. Guo, D. Rivero, and A. Pazos, "Epileptic seizure detection using multiwavelet transform based approximate entropy and artificial neural networks," *J. Neurosci. Methods*, vol. 193, no. 1, pp. 156–163, 2010.
- [16] R. Moshrefi, M. G. Mahjani, and M. Jafarian, "Application of wavelet entropy in analysis of electrochemical noise for corrosion type identification," *Electrochem. Commun.*, vol. 48, pp. 49–51, Nov. 2014.

- [17] D. Chen, S. Wan, J. Xiang, and F. S. Bao, "A high-performance seizure detection algorithm based on Discrete Wavelet Transform (DWT) and EEG," *PLoS ONE*, vol. 12, no. 3, Mar. 2017, Art. no. e0173138.
- [18] A. Sharmila and P. Geethanjali, "DWT based detection of epileptic seizure from eeg signals using naive Bayes and k-NN classifiers," *IEEE Access*, vol. 4, pp. 7716–7727, 2016.
- [19] S. Madan, K. Srivastava, A. Sharmila, and P. Mahalakshmi, "A case study on discrete wavelet transform based hurst exponent for epilepsy detection," *J. Med. Eng. Technol.*, vol. 42, no. 1, pp. 9–17, Jan. 2018.
- [20] D. Selvathi and V. K. Meera, "Realization of epileptic seizure detection in EEG signal using wavelet transform and SVM classifier," in *Proc. Int. Conf. Signal Process. Commun. (ICSPC)*, Coimbatore, India, Jul. 2017, pp. 18–22, doi: [10.1109/icspc.2017.8305848](https://doi.org/10.1109/icspc.2017.8305848).
- [21] B. Harender and R. K. Sharma, "DWT based epileptic seizure detection from EEG signal using k-NN classifier," in *Proc. Int. Conf. Trends Electron. Informat. (ICEI)*, Tirunelveli, India, May 2017, pp. 762–765, doi: [10.1109/icoei.2017.8300806](https://doi.org/10.1109/icoei.2017.8300806).
- [22] J. Lahmiri and A. Shmuel, "Accurate classification of seizure and seizure-free intervals of intracranial EEG signals from epileptic patients," *IEEE Trans. Instrum. Meas.*, vol. 68, no. 3, pp. 791–796, Mar. 2019, doi: [10.1109/tim.2018.2855518](https://doi.org/10.1109/tim.2018.2855518).
- [23] G. Wang, D. Ren, K. Li, D. Wang, M. Wang, and X. Yan, "EEG-based detection of epileptic seizures through the use of a directed transfer function method," *IEEE Access*, vol. 6, pp. 47189–47198, 2018, doi: [10.1109/access.2018.2867008](https://doi.org/10.1109/access.2018.2867008).
- [24] Z. Zakeri, S. Assecondi, A. P. Bagshaw, and T. N. Arvanitis, "Influence of signal preprocessing on ICA-based EEG decomposition," in *Proc. 13th Medit. Conf. Med. Biol. Eng. Comput.* Cham, Switzerland: Springer, 2013, pp. 734–737.
- [25] A. Hamad, E. H. Houssein, A. E. Hassaniien, and A. A. Fahmy, "A hybrid EEG signals classification approach based on grey wolf optimizer enhanced SVMs for epileptic detection," in *Proc. Int. Conf. Adv. Intell. Syst. Inform.* Cham, Switzerland: Springer, Sep. 2017, pp. 108–117.
- [26] A. Hamad, E. H. Houssein, A. E. Hassaniien, and A. A. Fahmy, "Hybrid grasshopper optimization algorithm and support vector machines for automatic seizure detection in EEG signals," in *Proc. Int. Conf. Adv. Mach. Learn. Technol. Appl.* Cham, Switzerland: Springer, Feb. 2018, pp. 82–91.
- [27] M. Kołodziej, A. Majkowski, and R. J. Rak, "A new method of EEG classification for BCI with feature extraction based on higher order statistics of wavelet components and selection with genetic algorithms," in *Proc. Int. Conf. Adapt. Natural Comput. Algorithms*. Berlin, Germany: Springer, Apr. 2011, pp. 280–289.
- [28] J. A. Nasiri, M. Sabzevar, H. S. Yazdi, M. Naghibzadeh, and B. Naghibzadeh, "Intelligent arrhythmia detection using genetic algorithm and emphatic SVM (ESVM)," in *Proc. 3rd UKSim Eur. Symp. Comput. Modeling Simulation*, Nov. 2009, pp. 112–117.
- [29] Y. Kaya, M. Uyar, R. Tekin, and S. Yildirim, "1D-local binary pattern based feature extraction for classification of epileptic EEG signals," *Appl. Math. Comput.*, vol. 243, pp. 209–219, Sep. 2014.
- [30] D. Torse, V. Desai, and R. Khanai, "A review on seizure detection systems with emphasis on multi-domain feature extraction and classification using machine learning," *BRAIN. Broad Res. Artif. Intell. Neurosci.*, vol. 8, no. 4, pp. 109–129, 2017.
- [31] A. S. Al-Fahoum and A. A. Al-Fraihat, "Methods of EEG signal features extraction using linear analysis in frequency and time-frequency domains," *ISRN Neurosci.*, vol. 2014, pp. 1–7, Feb. 2014.
- [32] U. R. Acharya, C. K. Chua, T.-C. Lim, Dorothy, and J. S. Suri, "Automatic identification of epileptic EEG signals using nonlinear parameters," *J. Mech. Med. Biol.*, vol. 9, no. 4, pp. 539–553, Dec. 2009, doi: [10.1142/S0219519409003152](https://doi.org/10.1142/S0219519409003152).
- [33] P. Jahankhani, J. A. Lara, A. Pérez, and J. P. Valente, "Two different approaches of feature extraction for classifying the EEG signals," in *Engineering Applications of Neural Networks*, vol. 363. L. Iliadis and C. Jayne. Berlin, Germany: Springer, 2011.
- [34] P. Jahankhani, V. Kodogiannis, and K. Revett, "EEG signal classification using wavelet feature extraction and neural networks," in *Proc. IEEE John Vincent Atanasoff Int. Symp. Mod. Comput. (JVA)*, Sofia, Bulgaria, Oct. 2006, pp. 120–124, doi: [10.1109/jva.2006.17](https://doi.org/10.1109/jva.2006.17).

**WAIL MARDINI** received the master's degree from the University of New Brunswick, Canada, in 2001, and the Ph.D. degree in computer science from the University of Ottawa, Canada, in 2006. He was the CS Department Chair, from 2010 to 2011 and 2011 to 2012, and the Faculty Vice-Dean,

from 2012 to 2013. He is currently a Professor of computer science and the Chairman of the Computer Science Department, Jordan University of Science and Technology (JUST), Jordan. He has been working at JUST, since 2006. He is currently working on wireless mesh networks, wireless sensor networks, optical network survivability, WiMax technology, scheduling in parallel computing, and intrusion detection in database techniques. He has many publications in the area of network survivability, wireless and wireless sensor networks, and optical wireless networks.

**MUNEER MASADEH BANI YASSEIN** (Member, IEEE) received the Ph.D. degree in computer science from the University of Glasgow, U.K., in 2007. He served as the Chairman of the Department of Computer Science, from 2008 to 2010, and the Vice Dean of the Faculty of Computer and Information Technology, from 2010 to 2012, 2013 to 2014, and 2018 to present. He is currently a Professor with the Department of Computer science, Jordan University of Science and Technology (JUST). He is conducting research in mobile ad hoc networks, wireless sensors networks, cloud computing, simulation and modeling, and the Internet of Things. During his career, he has supervised more than 70 graduate and undergraduate students. He has published over 170 technical articles in well reputed international journals and conferences. He is a member of the technical programs of several journals and conferences.

**RANA AL-RAWASHDEH** received the bachelor's degree in computer systems from Albalqa University, Jordan, in 2009, and the master's degree in computer science from the Jordan University of Science and Technology, Jordan, in 2019. Her research interests are in machine learning and data mining.

**SHADI ALJAWARNEH** received the B.Sc. degree in computer science from Jordan Yarmouk University, the M.Sc. degree in information technology from Western Sydney University, and the Ph.D. degree in software engineering from Northumbria University, England. He is currently a Full Professor of software engineering with the Jordan University of Science and Technology. He is a Professor of computer science. He is an ACM Senior Member. He has presented at and been on the organizing committees for a high number of international conferences and is a board member of the International Community for ACM, IEEE, Jordan ACM Chapter, ACS, and others. A good number of his articles have been selected as Best Papers at conferences and journals. Also, he has served as Conference Chair and TPC Chair for a good number of international conferences. Furthermore, he is an Associate Editor at *Electrical and Computer Engineering* journal, Elsevier and a Guest Editor for many journals special issues.

**YASER KHAMAYSEH** received the B.Sc. degree in computer science from Yarmouk University, Jordan, in 1998, the M.Sc. degree from the University of New Brunswick, Canada, in 2001, and the Ph.D. degree in computer science from the University of Alberta, Edmonton, Canada, in 2007. In 2007, he joined the Faculty of Computer and Information Technology, Jordan University of Science and Technology, Jordan, as an Assistant Professor of computer science. He is a Fulbright Scholar at Yale University, from 2019 to 2020. He is currently an Associate Professor with the Jordan University of Science and Technology. His research interests include wireless network optimization, resource management in wireless networks, and protocol design and analysis for future generation wireless communication networks and systems. He has served as a technical program committee member of various conferences.

**OMAR MEQDADI** received the Ph.D. degree in computer science from Kent State University, Ohio, USA. He was an Assistance Professor with the Department of Computer Science and Software Engineering, University of Wisconsin-Platteville, Wisconsin, USA. He is currently an Assistance Professor with the Department of Software Engineering, Jordan University of Science and Technology, Jordan. His research interest is in software engineering with a focus on software evolution.

• • •