

Received December 6, 2019, accepted December 18, 2019, date of publication January 6, 2020, date of current version January 15, 2020.

Digital Object Identifier 10.1109/ACCESS.2020.2964052

Energy Management System for Small Scale Hybrid Wind Solar Battery Based Microgrid

P. SATISH KUMAR¹, (Senior Member, IEEE), R. P. S. CHANDRASENA², V. RAMU³, G. N. SRINIVAS³, AND K. VICTOR SAM MOSES BABU¹, (Member, IEEE)

¹Department of Electrical Engineering, University College of Engineering, Osmania University, Hyderabad 500007, India

²Department of Electrical and Information Engineering, Faculty of Engineering, University of Ruhuna, Galle 80000, Sri Lanka

³Department of Electrical and Electronics Engineering, College of Engineering, Jawaharlal Nehru Technological University Hyderabad, Hyderabad 500085, India

Corresponding author: P. Satish Kumar (satish_8020@yahoo.co.in)

This work was supported by the Department of Science and Technology (DST), Government of India, and the Ministry of Science, Technology and Research (MSTR), Government of the Democratic Socialist Republic of Sri Lanka under Indo-Sri Lanka Joint Research Project at the Department of Electrical Engineering, University College of Engineering, Osmania University, India, and the Department of Electrical and Information Engineering, Faculty of Engineering, University of Ruhuna, Galle, Sri Lanka under Grant DST/INT/SL/P-18/2016, and the financial support for publication is provided by the Third Phase of Technical Education Quality Improvement Programme (TEQIP-III), Government of India.

ABSTRACT An efficient energy management system for a small-scale hybrid wind-solar-battery based microgrid is proposed in this paper. The wind and solar energy conversion systems and battery storage system have been developed along with power electronic converters, control algorithms and controllers to test the operation of hybrid microgrid. The power balance is maintained by an energy management system for the variations of renewable energy power generation and also for the load demand variations. This microgrid operates in standalone mode and provides a testing platform for different control algorithms, energy management systems and test conditions. A real-time control is performed by rapid control prototyping to test and validate the control algorithms of microgrid system experimentally. The proposed small-scale renewable energy based microgrid can be used as a test bench for research and testing of algorithms in smart grid applications.

INDEX TERMS Energy management system, hybrid system, microgrid, solar energy, standalone system, wind energy.

I. INTRODUCTION

There have been global initiatives for the promotion of self-sufficient renewable energy systems. This initiative has led to the development of renewable power generating systems which are capable of providing self-sufficient power generation with the use of more than one renewable source of energy [1], [2]. The most commonly used hybrid renewable energy sources are solar and wind energy [3], [4]. Both these sources of energy are intermittent in nature; therefore, the use of an energy storage system (ESS) is standard in stand-alone applications [5], [6]. In hybrid renewable energy systems; there are multiple control techniques to provide an efficient power transfer. The system design depends on the type of energy conversion system and the type of converters used at different locations in the system, this needs a lot of technical attention and has attracted research in this area [7]–[9].

The associate editor coordinating the review of this manuscript and approving it for publication was Bin Zhou¹.

A hybrid energy system was simulated and the performance for different practical load demand profile and weather data was studied [10]. The simulation system of a coordinated control for microgrid energy management in standalone and grid connected modes is discussed [11]. A hybrid wind-solar-battery ESS system is simulated to test the state of charge (SOC) control [12]. A scaled hardware prototype with battery SOC control scheme to improve the DC grid voltage control for stand-alone DC microgrid was developed [13]. A hardware prototype of a low-cost hybrid stand-alone power generation system was developed [14]. The objective of this research work is to design and develop a small-scale wind-solar-battery renewable energy based microgrid. An energy management system is proposed to maintain the power balance in the microgrid and provides a configurable and flexible control for different scenarios of load demand variations and variations in the renewable energy sources. The proposed system can be tested in real time environment with the use of rapid control prototyping. This test bench allows the

validation of control algorithms in real time and therefore develop efficient renewable energy management systems.

The rest of the paper is organized as follows; Section II illustrates the complete system design, converter topologies and control techniques in detail. Section III describes the hardware setup and the rapid control prototyping. Following that, the experiments on the microgrid and various results are discussed in Section IV. Lastly, this paper ends with conclusions and discussions in Section V.

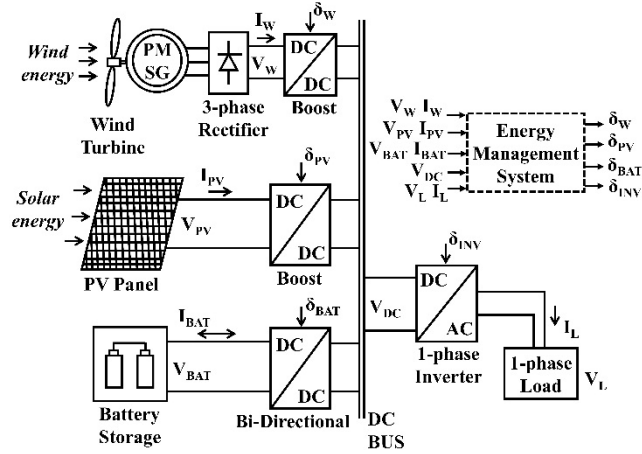

FIGURE 1. Components of small-scale wind-solar-battery microgrid with EMS.

II. SYSTEM DESCRIPTION

The proposed system is shown in Fig. 1. It can be divided into three parts; i) solar and wind based renewable energy sources supported by a battery storage system along with their converters connected to the DC bus, ii) the load side inverter and single-phase load, iii) real time controller implementing the energy management system. The wind energy conversion system consists of a permanent magnet synchronous generator (PMSG) based wind turbine. The solar photovoltaic (PV) panel is operated with maximum power point tracking (MPPT) when the power generated by both PV and wind are less than the load demand. When the power generated is more than the demand, the excess power is supplied to the battery and when it is no longer safe for the battery to be charged, the MPPT is turned off. The battery storage system is used to maintain the energy balance in the system. An energy management system is used to control the power flow under different conditions in order to supply to the load through a single-phase inverter.

A. SOLAR ENERGY CONVERSION SYSTEM (SECS)

The SECS consists of a solar PV panel, a DC-DC boost converter and an MPPT controller as shown in Fig. 2. Depending on state of charge of the battery storage system, the MPPT is operated under MPPT mode or under off-MPPT mode of operation.

The P-V characteristics of the solar panel with effect of irradiance is shown in Fig. 3. The characteristics are shown for different values of irradiance ranging from

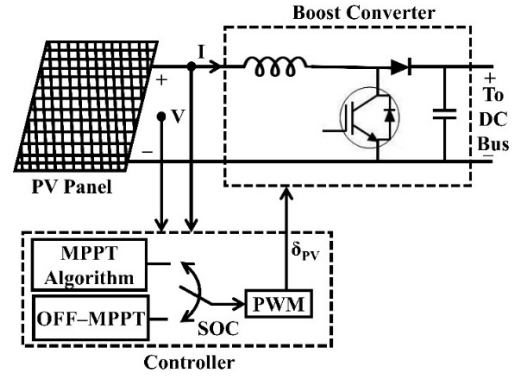

FIGURE 2. Solar energy conversion system with controller.

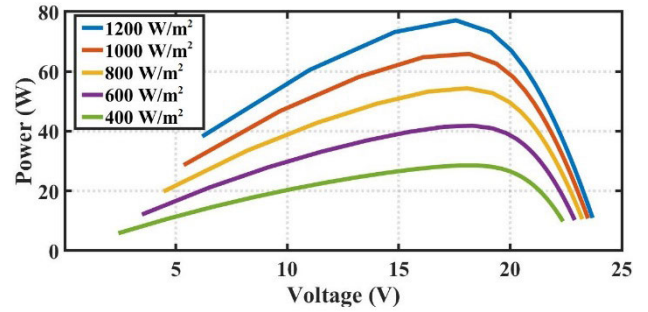

FIGURE 3. Effect of irradiance on PV array performance at T = 25°C.

400 W/m² to 1200 W/m² at a constant temperature of 25°C. For 1000 W/m², the power reaches a maximum of 66Wp at 17.6 V.

The power at the PV panel is

$$P_{pv} = VI \tag{1}$$

where, V is the voltage across the terminals of the PV panel and I is the current through it. The flow chart of the MPPT algorithm is shown in Fig. 4.

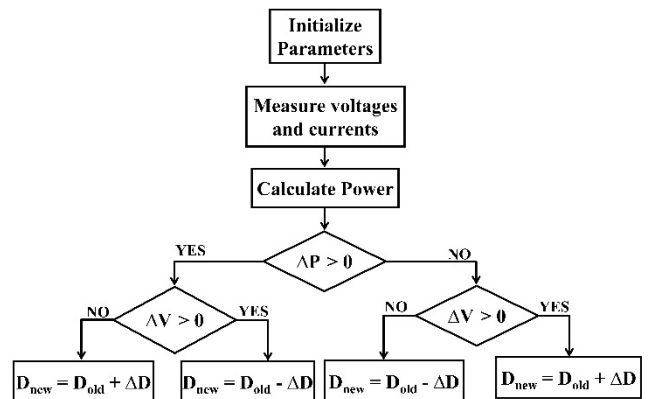

FIGURE 4. MPPT algorithm flow chart.

The MPPT algorithm in PV system keeps the PV panel voltage near to MPP voltage. The P&O method is used; the required change in the duty cycle (ΔD) is calculated based on the change in power (ΔP) and the change in voltage (ΔV).

First the voltage is perturbed and output power is calculated, if the power increases then voltage is increased further, if the power decreases then the voltage is reduced.

B. WIND ENERGY CONVERSION SYSTEM (WECS)

The WECS consists of a wind turbine, a PMSG, a DC-DC boost converter and controller. The power extracted from the wind is [15]

$$P_w = \frac{1}{2} \rho A v^3 C_p(\lambda, \theta) \tag{2}$$

where ρ is the air density in kg/m^3 , A is the area swept by the rotor blades in m^2 , and v is the wind velocity in m/s . C_p is the power coefficient and is a function of tip speed ratio (TSR, λ) and pitch angle (θ).

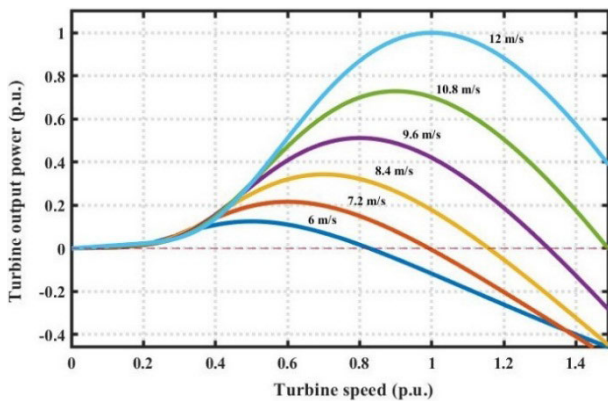

FIGURE 5. Mechanical characteristics of wind turbine for different wind speeds.

A variable speed wind turbine is used in this system. The characteristics of the wind turbine is shown in Fig. 5; the C_p for various wind speeds at different pitch angles. A permanent magnet synchronous generator is selected for its low maintenance and low operational cost. The generator output is dependent on the wind speed. The three-phase output of the generator is rectified using a diode rectifier and then the voltage level is increased with the help of a DC-DC boost converter as shown in Fig. 6.

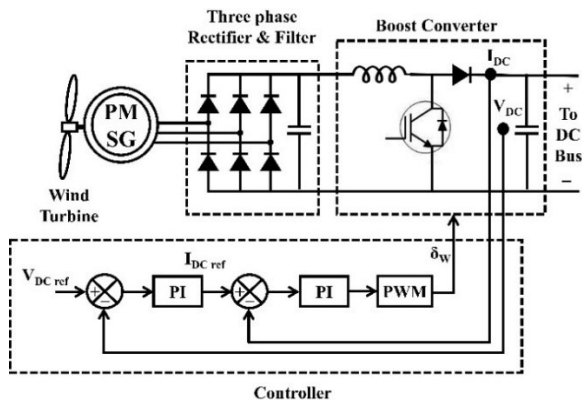

FIGURE 6. Wind energy conversion system with controller.

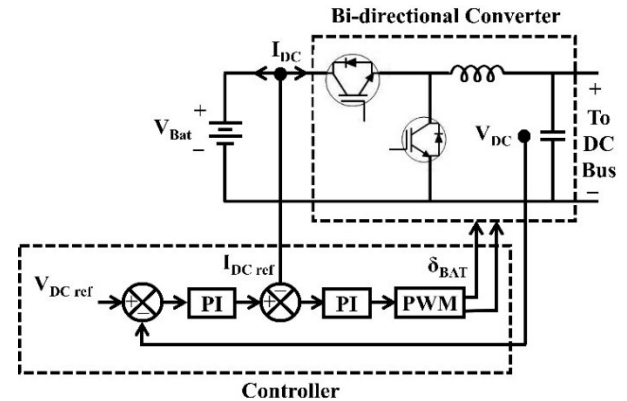

FIGURE 7. Battery energy storage system with controller.

C. BATTERY STORAGE SYSTEM (BSS)

The BSS consist of a lead acid battery and a bidirectional DC-DC buck-boost converter. This converter is responsible in maintaining the DC bus voltage through a PI controller as shown in Fig. 7. The state of charge (SOC) [16] is given as

$$SOC = 100 \left(1 + \frac{\int I_{bat} dt}{Q} \right) \tag{3}$$

where Q , is the battery capacity and I_{bat} is the battery current. The battery operates in two modes; charging and discharging, this depends on the power generated by both solar and wind. The battery also operates in these two modes based on the energy constraints which are determined by [16] the SOC limits

$$SOC_{min} \leq SOC \leq SOC_{max} \tag{4}$$

D. LOAD SIDE CONTROL

The DC microgrid is connected to a single-phase resistive load through a single-phase inverter with a controller shown in Fig. 8. A R-L filter is used at the inverter output to filter

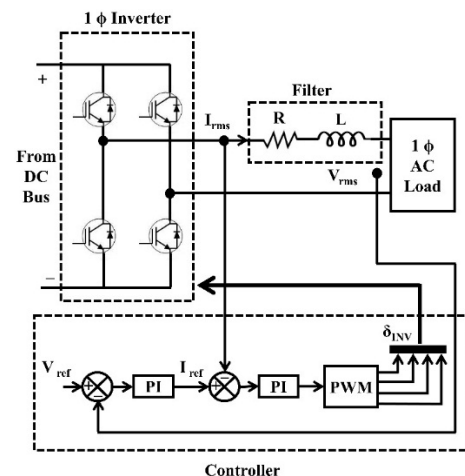

FIGURE 8. Single phase inverter with filter for AC load control.

the undesired harmonic content. The outer loop PI controller is used to regulate the voltage and the inner loop PI controller regulates the current.

E. ENERGY MANAGEMENT SYSTEM (EMS)

The EMS is the primary controller which coordinates and controls all control action in the microgrid system. All the controllers of the converters in the previous sections operate based on the EMS control mode. The boost converter of the solar energy conversion system operates in two modes depending on the power generation; MPPT mode/ off-MPPT mode. The Battery bidirectional converter operates in charging or discharging mode and maintains the DC bus voltage constant, the DC-DC boost converter of the wind energy conversion system operates in boost mode.

The power in the microgrid must be balanced under different generation of power from renewable energy sources and load demand conditions. The power balance equation is given as follows

$$P_w + P_{pv} = P_L + P_{bat} \tag{5}$$

The various modes of operation of the energy management system are presented in the flowchart in Fig. 9.

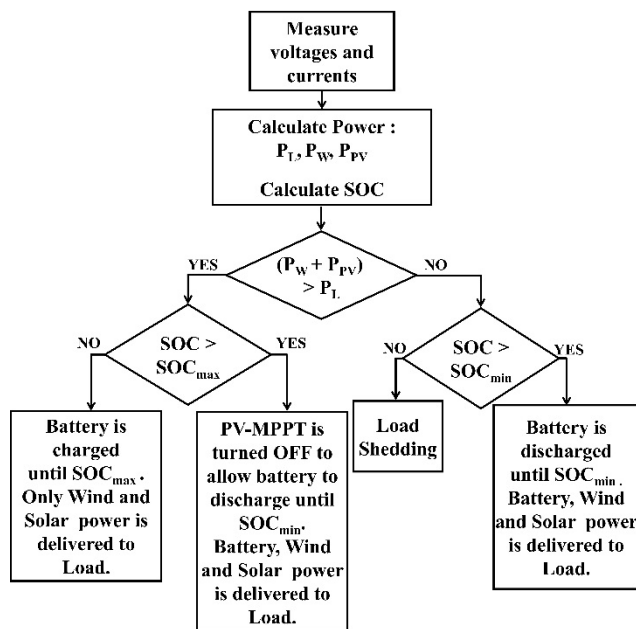

FIGURE 9. Energy management system.

There are four modes of operation of the energy management system. Each mode of operation depends on two conditions; one is the power generation and second is the state of charge of battery. The desired mode of operation is when the power generated from the SECS and WECS are more than the load demand. During this operation, the battery is charged until SOC_{max}, if the SOC of the battery reaches SOC_{max}, then the MPPT controller is switched to off-mode and this reduces the solar power generation as the total power generation is

more than the demand and the excess generated power can no longer be utilized to charge the battery and any further power requirement at the load is now supplied by the battery. When the power generated by the solar and wind energy sources do not meet the load demand, the power deficit is supplied by the battery until the SOC reaches SOC_{min}, once this is reached then load shedding needs to be done in order to maintain power balance as the power supply is less than demand.

III. EXPERIMENTAL SETUP AND RAPID CONTROL PROTOTYPING

The rapid control prototyping of the renewable energy based microgrid is implemented experimentally using a DSPACE DS1104 controller board as shown in Fig. 10. The DSPACE controller is a real-time hardware powered by a PowerPC microprocessor and supported by Texas Instruments TMS320F240 digital signal processor (DSP). The common control functions for are pre-defined in the DSP processor therefore there is no requirement of compiling a new user defined code. Also, by using Simulink Real-Time Workshop library the programs are compiled directly from the C-code for the PowerPC processor.

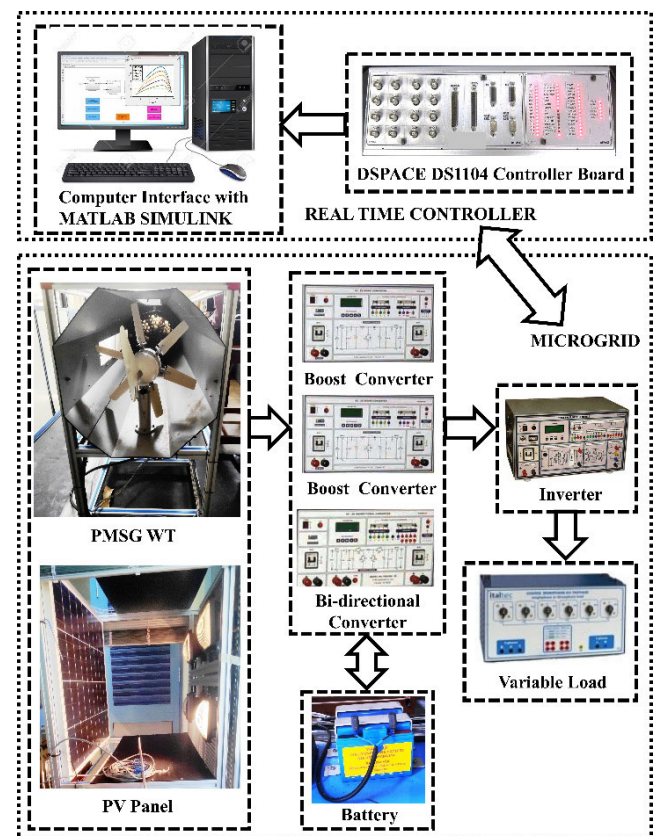

FIGURE 10. Rapid control prototyping of the renewable energy based microgrid.

The pulse with modulation (PWM) and serial peripheral interface are provided by DSP processor and the encoder interface and A/D modules are controlled by PowerPC

TABLE 1. Parameters of hardware equipment.

Equipment	Parameter	Value
PMSG	Nominal Power	60 W
	Nominal Voltage	24 V
	Nominal Current	4.2 A
	Rated Speed	6000 rpm
	Stator Resistance R_s	0.64 Ω
	Stator d axis inductance, L_d	0.16 mH
	Stator q axis inductance, L_q	0.16 mH
	Pole pairs, p	3
	Flux Linkage, ψ	0.024 Wb
	Coefficient of friction, K_g	0.37×10^{-6} N.m.s/rad
	Moment of Inertia, J_g	2×10^{-6} kg.m ²
PV Module	Nominal Power	70 W
	Open Circuit Voltage	24 V
	Maximum Power Point Voltage	17.6 V
	Short-Circuit Current	6 A
	Current at MPP	3.98 A
Battery	Voltage	12 V
	Capacity	24 Ah
DC Bus and RL Filter	DC-bus voltage reference, V_{DC}	50 V
	Filter resistance, R	0.7 Ω
	Filter inductance, L	32 mH

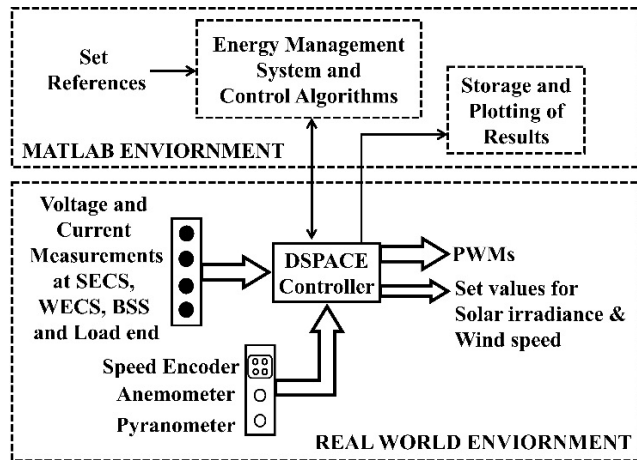

FIGURE 11. Schematic diagram of controller functions.

processor. Thus, this DS1104 board is an efficient real time controller which can be used for closed loop control applications.

The small scale microgrid consists of a controllable fan blower with which variation in wind speed can be achieved, this provides the necessary input to the 60W PMSG based wind turbine. Industrial lamps are used to vary the irradiation levels for a commercial 70W solar PV panel. A standard 12V, 24Ah lead acid battery is used. Appropriate power electric converters for PV panel, generator, battery and load are selected. Necessary encoders, line filter inductors, low power variable load module, interface and voltage and

current measuring equipment are utilized. A list of parameters of the hardware equipment is provided in Table 1.

In Fig. 11, the functions of the controller are clearly represented in the schematic diagram. The RCP accommodates the variations in the user inputs, variations in the control functions and variations in the hardware operations in real time. The DSPACE controller receives the voltage and current measurements from solar and wind energy conversion systems, battery storage system and load end along with the speed of the PMSG, wind speed measurement and solar irradiance measurement provided by the encoder, anemometer and pyranometer respectively, these measurements are given to the energy management system and control algorithms for the calculation of power at different locations of the microgrid and to assess the control action to be taken to maintain the energy balance in the system and also generate the necessary PWMs to the power electronic converters. Set references such as irradiance values to maintain the intensity of the solar lamps and also the wind speed values to maintain the speed of the blower in order to test performance of the microgrid for the variations in the renewable energy sources, these set references are sent through the controller. In the matlab environment, both the controller design and implementation is executed and also the storage and plotting of results is done. The stored results can also be analysed at a later time.

IV. EXPERIMENTAL RESULTS

There were two case scenarios that were carried out on the hybrid renewable energy microgrid. The first case was performed at a constant load condition and the solar and wind energy was varied. The second case was carried out for variations in load demand with constant renewable energy sources. The runtime for the experiment results for both cases is 70s.

A. VARIATIONS IN RENEWABLE ENERGY SOURCES WITH A CONSTANT LOAD

The objective of the first case is to deliver a constant power to the load for different generating conditions. The solar irradiance is varied by switching the lamps on/off and thus providing different irradiance levels. The wind speed is varied by varying the speed of the fan blower. The irradiance is varied by 1000W/m², 800W/m², 400W/m² and 600W/m² at the start, 20s, 30s and 50s respectively, the wind speed was varied by 12m/s, 8 m/s, 11m/s, 7 m/s and 11 m/s at the start, 10s, 20s, 40s and 60s respectively as shown in Fig. 12.

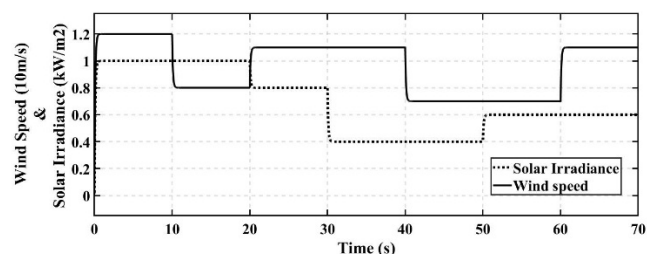

FIGURE 12. Wind speed and solar irradiance levels.

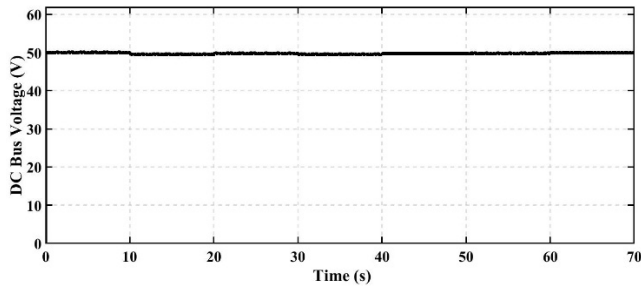

FIGURE 13. DC bus voltage for constant load with variable renewable energy sources.

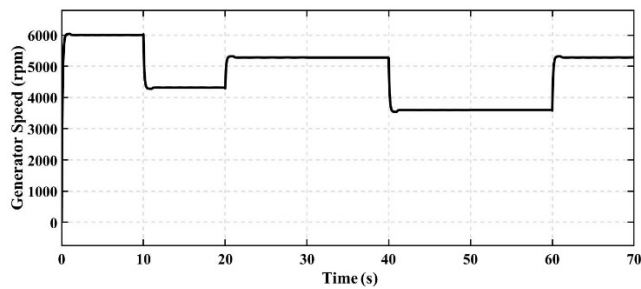

FIGURE 14. PMSG speed for constant load with variable renewable energy sources.

Though the variations in the wind speed and solar irradiance are only step variations which can never happen in the real world as the meteorological conditions are always changing. These values are selected in such a manner that they vary between the possible maximum and minimum range of operation of the PV panel and WT in order to check the system operation for these variations. Also, in this case, the load is kept fixed which would not occur in a practical situation. But the load is kept fixed in order to observe the performance operation of the renewable energy conversion systems and the battery storage system for the variations in the power generated from the renewable energy sources, this will be difficult to observe if the load is constantly changing.

The power balance is achieved by the energy storage device by maintaining a constant DC bus voltage of 50V as shown in Fig. 13. The generator speed for different variations of wind speed is shown in Fig. 14.

The power at different locations of the microgrid is shown in Fig. 15, till 10s, the battery is charged as the power generated by both the solar and wind energy conversion systems exceeds the load demand, after 10s the discharging starts and the level of discharge varies at different instants depending on the difference in the power deficit from the renewable energy sources.

The power deficit is met by the battery, and the state of charge of the battery clearly shows the charging and discharging rate in Fig. 16. The voltage is kept at constant at the load terminal as shown in Fig. 17; for few instances the load voltage drops marginally as the battery discharge rate is higher between 40s to 60s.

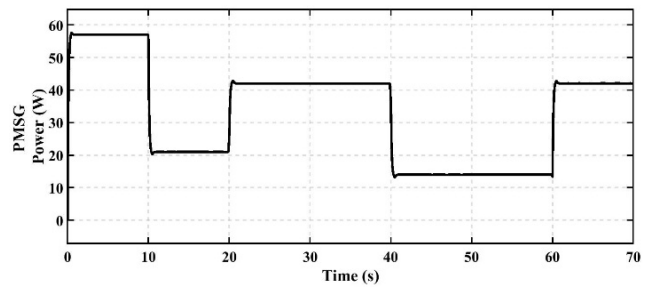

(a) PMSG Power

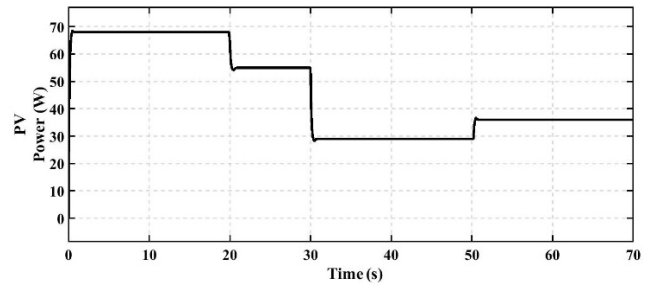

(b) PV Power

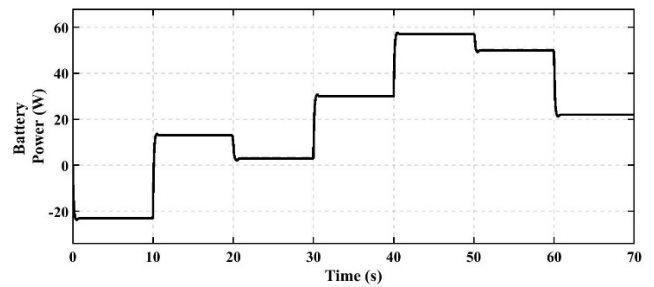

(c) Battery Power

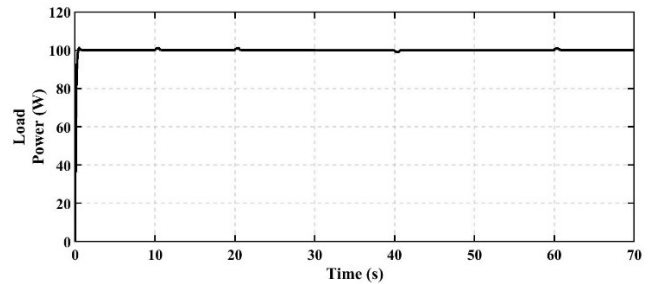

(d) Load Power

FIGURE 15. Power at different locations of the microgrid for constant load with variable renewable energy sources.

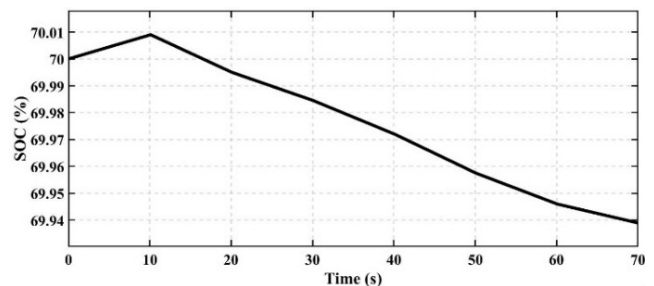

FIGURE 16. State of charge of battery for constant load with variable renewable energy sources.

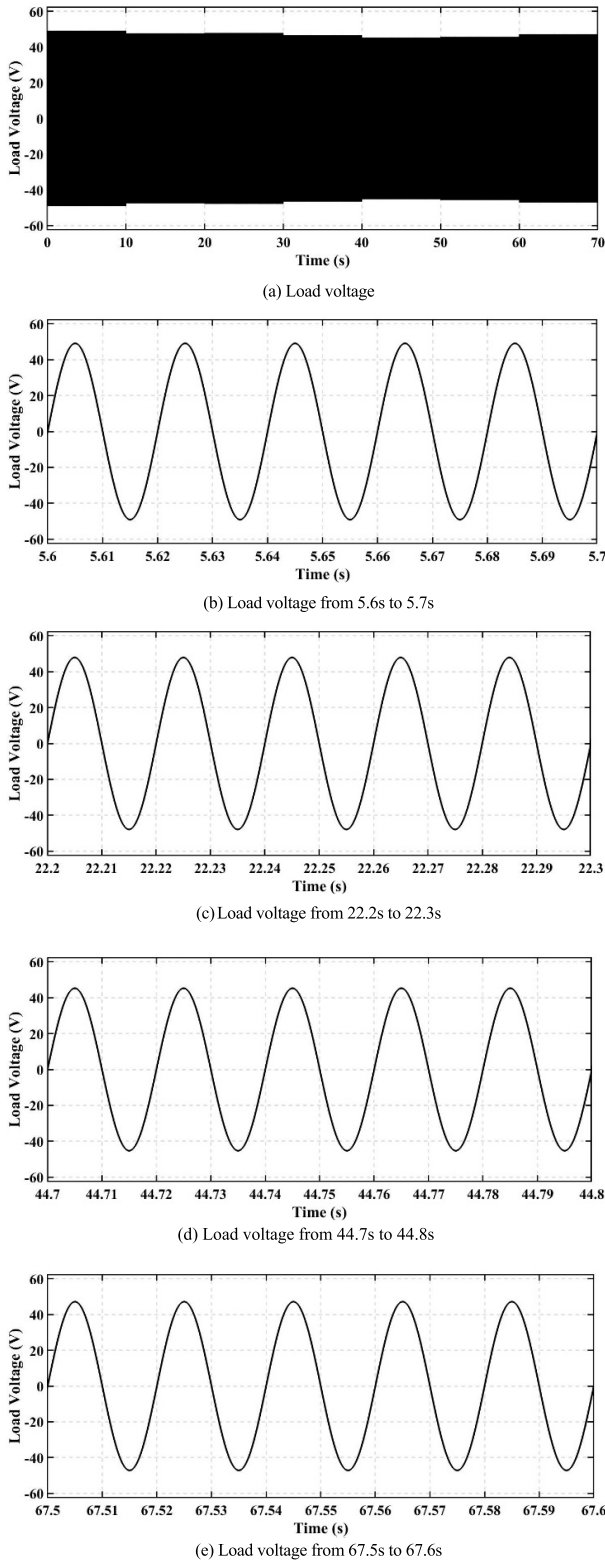

FIGURE 17. Load voltage for constant load with variable renewable energy sources.

B. VARIATIONS IN LOAD WITH CONSTANT RENEWABLE ENERGY SOURCES

In the second case scenario, the solar and wind power generation is kept constant with the solar irradiance kept constant

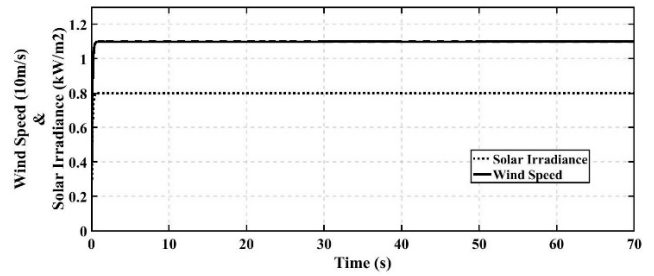

FIGURE 18. Wind speed and solar irradiance levels.

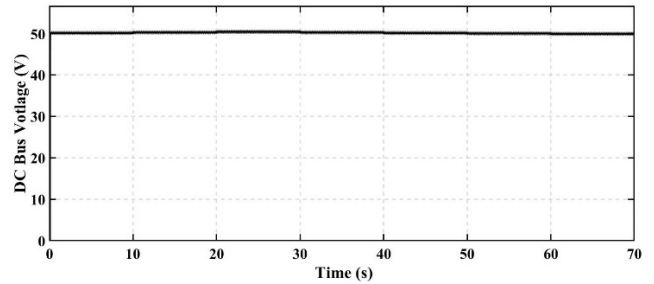

FIGURE 19. DC bus voltage for constant renewable energy sources with variable load.

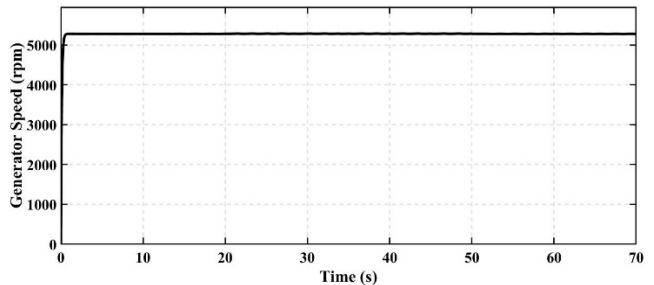

FIGURE 20. PMSG speed for constant renewable energy sources with variable load.

at $800W/m^2$ and the wind speed kept constant at 11m/s as shown in Fig. 18. The power balance is achieved by the energy storage device which maintains a constant DC bus voltage at 50V as shown in Fig. 19. The generator speed is constant at a speed of 5280 rpm as the wind speed is maintained constant shown in Fig. 20.

The load is varied at every 10s and the performance of the microgrid is tested for a variable load demand. The power at different location of the microgrid is shown in Fig. 21. Initially the load demand is 100W and the power generated from the renewable sources is slightly less than the demand and this is met by the battery. After 10s until 40s, the demand is lower and during this time the battery is charged from the excess power generation. After 40s, the demand is more than the supply and the battery supplies the additional power required.

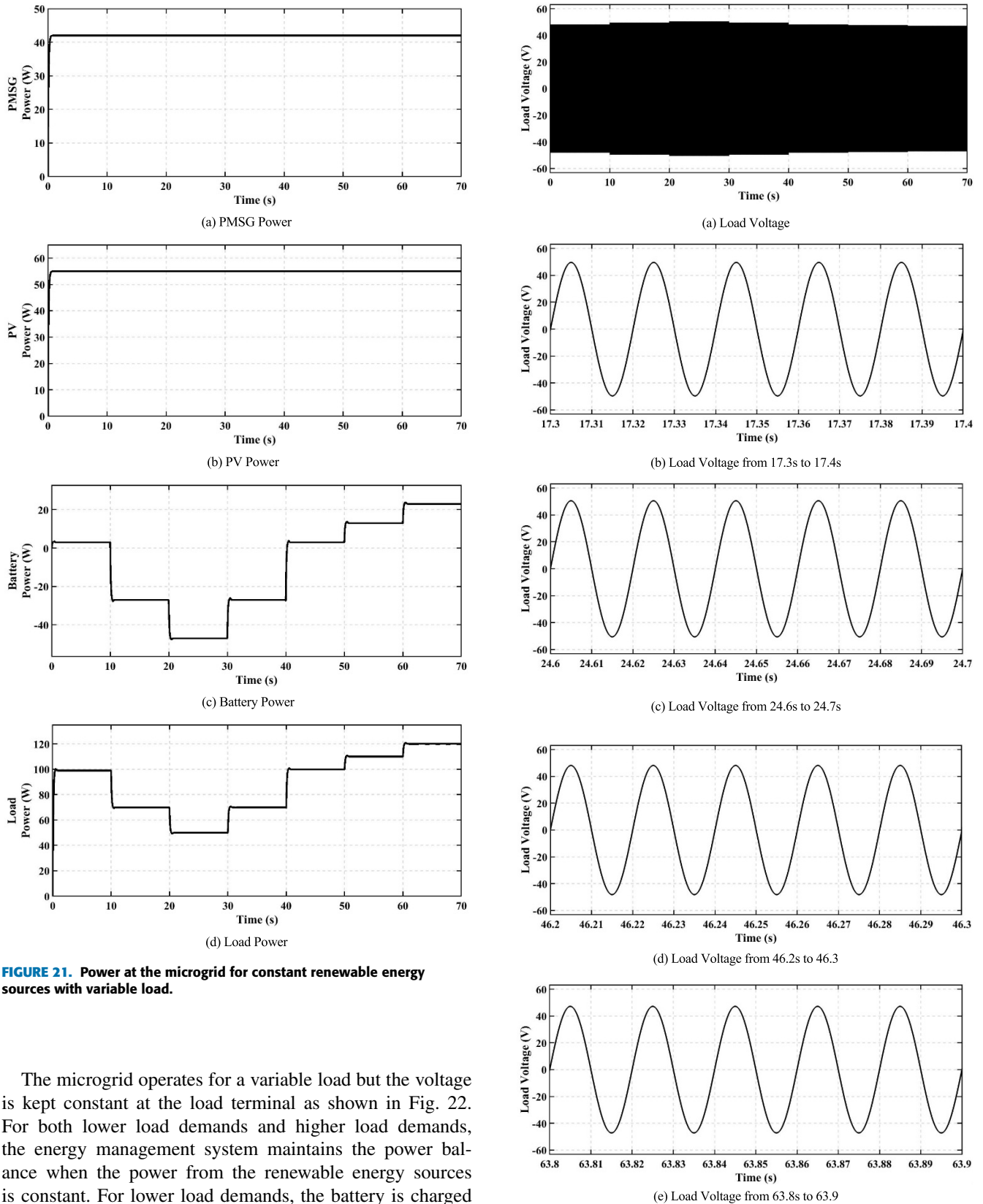

FIGURE 21. Power at the microgrid for constant renewable energy sources with variable load.

The microgrid operates for a variable load but the voltage is kept constant at the load terminal as shown in Fig. 22. For both lower load demands and higher load demands, the energy management system maintains the power balance when the power from the renewable energy sources is constant. For lower load demands, the battery is charged and for higher load demands, the battery discharges and the variations in the SOC of the battery is shown in Fig. 23.

FIGURE 22. Load voltage for constant renewable energy sources with variable load.

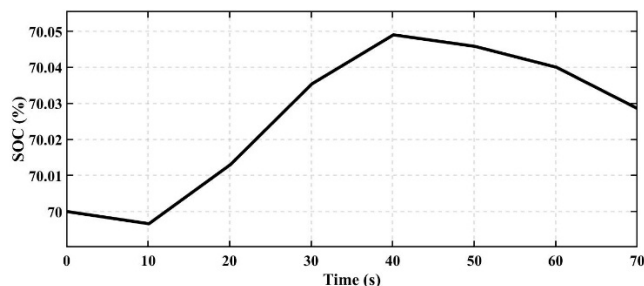

FIGURE 23. State of charge of battery for constant renewable energy sources with variable load.

V. CONCLUSION

A small-scale experimental hybrid solar-wind-battery renewable energy based microgrid with energy management system is developed and implemented. Experiments were conducted to test the effectiveness of the proposed energy management system for different variations in the renewable energy sources and different variations in the load demand. The energy management system and control algorithms were implemented using rapid control prototyping in DSPACE controller. The experimental results show that the system is flexible and accommodates the different variations in the renewable energy sources and in the load. The controller allows the effective implementation of the energy management system. This test bench provides a platform in which future tests can be performed for different case scenarios and control algorithms for research in the field of hybrid renewable energy microgrid systems.

REFERENCES

- [1] A. Qazi, F. Hussain, N. A. Rahim, G. Hardaker, D. Alghazzawi, K. Shaban, and K. Haruna, "Towards sustainable energy: A systematic review of renewable energy sources, technologies, and public opinions," *IEEE Access*, vol. 7, pp. 63837–63851, 2019.
- [2] T. Mai, "Renewable electricity futures for the United States," *IEEE Trans. Sustain. Energy*, vol. 5, no. 2, pp. 372–378, Apr. 2014.
- [3] M. H. Nehrir, C. Wang, K. Strunz, H. Aki, R. Ramakumar, J. Bing, Z. Miao, and Z. Salameh, "A review of hybrid renewable/alternative energy systems for electric power generation: Configurations, control, and applications," *IEEE Trans. Sustain. Energy*, vol. 2, no. 4, pp. 392–403, Oct. 2011.
- [4] M. S. Pranav, "Hybrid renewable energy sources (HRES)—A review," in *Proc. Int. Conf. Intell. Comput., Instrum. Control Technol. (ICICICT)*, 2017, pp. 162–165.
- [5] X. Song, Y. Zhao, J. Zhou, and Z. Weng, "Reliability varying characteristics of PV-ESS-based standalone microgrid," *IEEE Access*, vol. 7, pp. 120872–120883, 2019.
- [6] A. Jamali, N. M. Nor, and T. Ibrahim, "Energy storage systems and their sizing techniques in power system—A review," in *Proc. IEEE Conf. Energy Convers. (CENCON)*, Oct. 2015, pp. 215–220.
- [7] C. Wang, H. Nehrir, F. Lin, and J. Zhao, "From hybrid energy systems to microgrids: Hybridization techniques, configuration, and control," in *Proc. IEEE PES Gen. Meeting*, Jul. 2010, pp. 1–4.
- [8] S. K. Sahoo, "Control techniques in AC, DC, and hybrid AC-DC microgrid: A review," *IEEE J. Emerg. Sel. Topics Power Electron.*, vol. 6, no. 2, pp. 738–759, Jun. 2018.
- [9] J. Esch, "High-power wind energy conversion systems: State-of-the-art and emerging technologies," *Proc. IEEE*, vol. 103, no. 5, pp. 736–739, May 2015.
- [10] C. Wang and M. Nehrir, "Power management of a stand-alone wind/photovoltaic/fuel cell energy system," *IEEE Trans. Energy Convers.*, vol. 23, no. 3, pp. 957–967, Sep. 2008.
- [11] Q. Jiang, M. Xue, and G. Geng, "Energy management of microgrid in grid-connected and stand-alone modes," *IEEE Trans. Power Syst.*, vol. 28, no. 3, pp. 3380–3389, Aug. 2013.
- [12] X. Li, D. Hui, and X. Lai, "Battery energy storage station (BESS)-based smoothing control of photovoltaic (PV) and wind power generation fluctuations," *IEEE Trans. Sustain. Energy*, vol. 4, no. 2, pp. 464–473, Apr. 2013.
- [13] B.-M. Han, "Battery SoC-based DC output voltage control of BESS in stand-alone DC microgrid," in *Proc. IEEE Region 10 Conf. (TENCON)*, Nov. 2016, pp. 1445–1449.
- [14] C. Kalaivani, D. Divyalakshmi, and N. P. Subramaniam, "A standalone hybrid power generation system," in *Proc. Int. Conf. Comput. Power, Energy Inf. Commun. (ICCPEIC)*, Mar. 2017, pp. 800–806.
- [15] F. Blaabjerg, Z. Chen, and S. Kjaer, "Power electronics as efficient interface in dispersed power generation systems," *IEEE Trans. Power Electron.*, vol. 19, no. 5, pp. 1184–1194, Sep. 2004.
- [16] S. X. Chen, "Sizing of energy storage for microgrids," *IEEE Trans. Smart Grid*, vol. 3, no. 1, pp. 142–151, Mar. 2012.



P. SATISH KUMAR (Senior Member, IEEE) received the B.Tech. degree in EEE and the M.Tech. degree in power electronics from JNTUH, and the Ph.D. degree in the area of multilevel inverters from JNTUH, in 2011. He is currently an Associate Professor with the Department of Electrical Engineering, University College of Engineering, Osmania University, Hyderabad, India. He has more than 23 years of teaching and research experience, with four Ph.D.'s awarded under his supervision and is currently guiding eight Ph.D. scholars in the area of power electronics. He visited USA, France, Switzerland, Japan, Singapore, Hong Kong, Bangkok, and Sri Lanka to present his research articles in various international conferences. He has published 93 research articles in international journals and has presented 32 papers in international conferences and filed three patents in the area of multilevel inverters. He authored one text book entitled *Pulse Width Modulation: Analysis and Performance in Multilevel Inverters*. His areas of interests include power electronics, drives, power converters, multilevel inverters, special machines, and renewable energy sources.

Dr. Kumar is a member of ISTE, Fellow of IET, and an editorial member of various international journals. As a Principal Investigator, he completed two Major Research Projects funded by UGC and SERB, Government of India. He is currently implementing Indo-Sri Lanka joint research project sponsored by the DST, Government of India. He received the Best Teacher Award from the State Government of Telangana, in September 2014, the Fast Track Scheme for Young Scientist Award from SERB, in 2013, the Award for Research Excellence, in 2014, and the Global Teacher Role Model Award, in 2015.



R. P. S. CHANDRASENA received the B.Sc. degree (Eng.) from the Faculty of Engineering, University of Peradeniya, Sri Lanka, in 1998, and the M.Eng. degree from the Faculty of Engineering, University of Moratuwa, Sri Lanka, in 2004, the M.Phil. degree in electrical engineering from the Faculty of Engineering, University of Peradeniya, in 2011, and the Ph.D. degree in the area of converter control in microgrid from the Faculty of Engineering, Curtin University, Australia, in 2015.

He is currently a Senior Lecturer with the Department of Electrical and Information Engineering, Faculty of Engineering, University of Ruhuna, Sri Lanka. He has more than 15 years' experience as an Academic. He published more than 15 publications in international journals and conferences. He is currently supervising one M.Phil. student and he has taught undergraduate courses, such as electrical machines, power systems, and power electronics. He has coauthored a book chapter in the book *Renewable Energy Integration: Challenges and Solutions* (Springer Press, Singapore, 2014). His areas of interests include power electronic converter control, microgrids, and renewable energy generation. He received the IET Premium Award 2015 and also received the Research Grant worth around five million rupees for a joint project proposal submitted to the Ministry of Science, Technology and Research, Sri Lanka, under the Indo-Sri Lanka Joint Research Program.



V. RAMU received the M.Tech. degree in power systems with emphasis on high voltage engineering from JNTU, Kakinada, in 2008. He is currently pursuing the Ph.D. with JNTUH, India. He is also an Assistant Professor with the Department of Electrical Engineering, University College of Engineering, Kakatiya University, Kothagudem. He has 17 years of teaching experience and has seven years of research experience. He has published four international journals and one international conference. His research areas include renewable energy sources, power electronics, electric drives, and multilevel inverters.



G. N. SRINIVAS received the B.Tech. degree in EEE from the JNTU College of Engineering, Hyderabad, India, the M.E. degree in power systems from the College of Engineering, Osmania University, Hyderabad, and the Ph.D. degree from JNTUH, India. He has 23 years of teaching and research experience. He is currently a Professor and the Vice-Principal of the College of Engineering, JNTUH. He has presented over 26 research articles in national and international conferences in

India and abroad and has published 22 research articles in national and international journals and guided 20 B.Tech. projects and 68 M.Tech. projects. He has authored a text book “*Electrical and Electronics Measurements and Instrumentation*” (BS Publishers, Hyderabad). He is a Life Member of the System Society of India. His research interests include hybrid renewable energy stand-alone and grid-tied systems, energy management systems, multilevel inverters, power converters, and electric drives. His two research scholars were awarded the Ph.D. degree and one has submitted Ph.D. thesis and currently eight research scholars are pursuing their Ph.D. degree under his supervision. He received the Telugu Vignana Parithoshikam for obtaining District First Rank in Intermediate.



K. VICTOR SAM MOSES BABU received the B.E. degree from Karunya University, Coimbatore, India, in 2011, and the M.E. degree in power electronics and drives from the Sona College of Technology, Salem, in 2014. He is currently a Junior Research Fellow with the Department of Electrical Engineering, University College of Engineering, Osmania University, Hyderabad, India, under the Indo-Sri Lanka Joint Project, sponsored by DST, Government of India. He has five years of teaching and research experience. His research interests include hybrid renewable energy-based standalone and grid-tied systems, energy management systems, artificial intelligence-based controllers, multilevel inverters, special electrical machines, power electronic converters, and electric drives.

...