

Received October 23, 2019, accepted November 3, 2019, date of publication November 7, 2019, date of current version November 19, 2019.

Digital Object Identifier 10.1109/ACCESS.2019.2952071

Resource Allocation-Based PAPR Analysis in Uplink SCMA-OFDM Systems

ADITYA S. RAJASEKARAN^{1,2,3}, (Member, IEEE),
MONIROSHARIEH VAMEGHESTAHBANATI^{1,3}, MOHAMMAD FARSI^{1,3},
HALIM YANIKOMEROGLU^{1,3}, (Fellow, IEEE), AND HAMID SAEEDI^{1,3}, (Member, IEEE)

¹Department of Systems and Computer Engineering, Carleton University, Ottawa, ON K1S 5B6, Canada

²Ericsson Canada Inc., Ottawa, ON K2K 2V6, Canada

³Department of Electrical and Computer Engineering, Tarbiat Modares University, Tehran 14115-111, Iran

Corresponding author: Aditya S. Rajasekaran (aditya.rajasekaran@carleton.ca)

This work was supported by the Discovery Grant of the Natural Sciences and Engineering Research Council of Canada. The work of R. Aditya was supported by the Ericsson Canada Inc., in the form of Tuition Assistance.

ABSTRACT Sparse code multiple access (SCMA) is a non-orthogonal multiple access (NOMA) uplink solution that overloads resource elements (RE's) with more than one user. Given the success of orthogonal frequency division multiplexing (OFDM) systems, SCMA will likely be deployed as a multiple access scheme over OFDM, called an SCMA-OFDM system. One of the major challenges with OFDM systems is the high peak-to-average power ratio (PAPR) problem, which is typically studied through the PAPR statistics for a system with a large number of independently modulated sub-carriers (SCs). In the context of SCMA systems, the PAPR problem has been studied before through the SCMA codebook design for certain narrowband scenarios, applicable more for low-rate users. However, we show that for high-rate users in wideband systems, it is more meaningful to study the PAPR statistics. In this paper, we highlight some novel aspects to the PAPR statistics for SCMA-OFDM systems that is different from the vast body of existing PAPR literature in the context of traditional OFDM systems. The main difference lies in the fact that the SCs are not independently modulated in SCMA-OFDM systems. Instead, the SCMA codebook uses multi-dimensional constellations, leading to a statistical dependency between the data carrying SCs. Further, the SCMA codebook dictates that an UL user can only transmit on a subset of the available SCs. We highlight the joint effect of the two major factors that influence the PAPR statistics - the phase bias in the multi-dimensional constellation design along with the resource allocation strategy. The choice of modulation scheme and SC allocation strategy are static configuration options, thus allowing for PAPR reduction opportunities in SCMA-OFDM systems through the setting of static configuration parameters. Compared to the class of PAPR reduction techniques in the OFDM literature that rely on multiple signalling and probabilistic techniques, these gains come with no computational overhead. In this paper, we also examine these PAPR reduction techniques and their applicability to SCMA-OFDM systems.

INDEX TERMS Sparse code multiple access (SCMA), peak-to-average power ratio (PAPR), orthogonal frequency division multiplexing (OFDM), sub-carrier (SC), uplink (UL), selective mapping (SLM), inter-leaving (IL).

I. INTRODUCTION

Non-orthogonal multiple access (NOMA) solutions are being actively studied to address the massive connectivity requirements for 5G and beyond 5G (B5G) communication systems [1]. The sparse code multiple access (SCMA), proposed

The associate editor coordinating the review of this manuscript and approving it for publication was Zhen Ren¹.

in [2], is one such NOMA scheme that has received a lot of attention particularly for the uplink (UL) direction [3]. SCMA will likely be used as a multiple access scheme over orthogonal frequency division multiplexing (OFDM), which is referred to as an SCMA-OFDM system [4], [5]. In SCMA-OFDM systems, the orthogonal OFDM sub-carriers (SCs) are the resource elements (RE's) over which the SCMA codewords are spread. Traditional OFDM systems that

independently modulate the individual SCs are known to create large power peaks compared to the average power, resulting in the well known peak-to-average power ratio (PAPR) problem [6]. A high PAPR means that the power amplifier needs to operate in an inefficient region to avoid power leakage, which in turn affects the battery-life of the transmitting UL end-user device. The article in [7] highlights the high PAPR problem in OFDM systems while also describing why operators are unlikely to opt for a NOMA scheme that does away with OFDM entirely. Hence, studying the PAPR problem in an OFDM system that uses a NOMA scheme like SCMA is an important problem for 5G and beyond communication systems as highlighted by [7].

In the context of traditional OFDM systems that independently modulate a large number of SCs, the PAPR attained is a random quantity, since it depends on the sequence of complex-valued constellation points transmitted in the OFDM SCs along with the symbol rate. The PAPR can then be analysed in terms of its maximum theoretically attainable value based on the constellation scheme used to modulate the individual SCs. Alternatively, the PAPR can be studied in terms of its statistics using the complementary cumulative distribution function (CCDF), often referred to as the PAPR statistics [8]. It has been shown that when the number of SCs is sufficiently large, the maximum theoretically attainable PAPR value occurs with negligible probability and the PAPR statistics offer more meaningful insights [8]–[11]. Since traditional OFDM systems typically involve independently modulated SCs, the PAPR statistics have been characterized with this assumption in several studies [9], [11], [12]. However, using SCMA as a multiple access scheme over OFDM means that the individual SCs are not independently modulated; thus motivating the need to characterize the PAPR analysis specifically for SCMA-OFDM systems.

In the SCMA construct, each user maps its incoming bits to a multi-dimensional modulation symbol coded over multiple RE's, which is termed as a codeword. Each modulation symbol has its own codeword and together they form a codebook that is ideally unique to a user. In this way, the users are separated by their unique codebooks. The SCMA codebook design problem involves the multi-dimensional constellation design [3] and several such constellations have been proposed in the literature [13]–[17]. This SCMA codebook design provides an additional degree of freedom to the PAPR problem in SCMA based systems [18] and corresponding multi-dimensional constellation schemes that minimize the PAPR that can theoretically be attained have been proposed in [19]–[22]. However, we show in this paper that like with traditional OFDM systems, this maximum theoretically attainable PAPR based on the codebook design is a meaningful metric only for low-rate users or in narrow-band systems. For high rate users, i.e., when a larger number of modulation symbols are transmitted in the same OFDM symbol duration, it is more meaningful to study the PAPR statistics. While the SCMA paradigm is often discussed for massive connectivity deployment involving low-rate IoT devices [18], SCMA can

just as easily be used for traditional wireless devices and other high-rate users in 5G and B5G networks [4], [5], [23]. The characteristics of the SCMA codebook that affect the PAPR statistics are different from those studied to date in the SCMA literature to the best of our knowledge, and is the focus of this paper.

Since SCMA employs multi-dimensional constellations, each modulation symbol is transmitted over multiple individual SCs. Thus, the transmitted OFDM SCs are not independently modulated like they are in traditional OFDM systems. The multi-dimensional constellation design dictates what is transmitted in the individual SCs. The PAPR statistics in SCMA-OFDM systems will thus reflect this dependency between the modulated SCs. For instance, if the SCMA codeword consists of constellation points all of the same phase and the SCs over which they are transmitted are contiguous, it will have a detrimental effect on the PAPR statistics. Alternatively, an SCMA scheme where the codewords contain constellation points of opposite phases and transmitted over contiguous SCs is likely to have a positive effect on the PAPR statistics. However, the SCs carrying SCMA codewords do not necessarily have to be contiguous SCs. In other words, the SCs that carry the codewords can be located anywhere in the frequency spectrum. Hence, the joint impact of the SCMA modulation scheme along with the OFDM SC placement must be considered when studying the PAPR statistics for high-rate SCMA-OFDM users.

In this paper, we highlight these novel aspects to the PAPR analysis for SCMA-OFDM systems that is different from the vast body of existing PAPR literature in the context of traditional OFDM systems. We highlight two major factors that influence the PAPR statistics - the phase bias in the multi-dimensional constellation design along with the resource allocation strategy.¹ By considering such a cross-layer systematization perspective, we motivate the fact that significant PAPR reduction can be achieved through the setting of static configuration parameters. Such gains could come without any additional overhead to the system that is typically introduced by most multiple signalling based PAPR reduction techniques that work with the assumption of independently modulated SCs, i.e., no a-priori knowledge of any statistical dependencies in the transmitted signal [6].

Further, in the context of traditional OFDM systems, numerous techniques that improve the PAPR statistics have been proposed, as captured by the surveys in [6], [24], [25]. Broadly, there are two categories of such PAPR reduction techniques: signal distortion based techniques and multiple signalling and probabilistic based techniques. Signal distortion techniques like clipping distort the transmitted signal by not transmitting any power peaks above a certain threshold [26]. Alternatively, PAPR reduction techniques based on multiple signalling generate a set of candidate signals

¹The placement of the SCs that carry an SCMA codeword is basically a resource allocation problem. In this paper, we use the terms resource allocation and SC placement interchangeably.

every OFDM symbol and transmit the signal with the least PAPR. The set of candidate signals are generated through operations like phase changes [27] or interleaving [28] on the original data set. There is a significant complexity overhead in generating these extra candidate signals as well as some throughput loss since sidelink information about the operations performed on the data set needs to be transmitted to the receiver [6].

In [4] and [5], the class of signal distortion techniques is studied in the context of high-rate SCMA-OFDM systems. Specifically, these two papers investigate the challenge of allowing the SCMA receiver to cope with the distortions introduced by signal clipping at the transmitter. However, the class of multiple signalling and probabilistic techniques has not been thoroughly examined in the context of SCMA-OFDM systems to the best of the authors knowledge. As we discuss in this paper, some of the techniques that involve constellation shaping [29], [30] cannot easily lend itself to SCMA systems because it affects the SCMA constellation design. However, other multiple signalling techniques such as selective mapping (SLM) [27], partial transmit sequences (PTS) [31] and interleaving (IL) [28] can be tailored to meet the constraints of an SCMA-OFDM system. In this paper, we discuss what adaptations are needed to these well known PAPR reduction techniques to make them work in SCMA-OFDM systems. Moreover, in traditional OFDM systems where each SC is independently modulated, until the SCs to be transmitted in an OFDM symbol are known, there is no way to know which SC allocation strategy results in the least PAPR. Hence, a certain number of permutations are tried dynamically every OFDM symbol and the one with the least PAPR is transmitted. However, with SCMA-OFDM systems, we can exploit the statistics known in advance through the novel aspects we present in this paper to reduce or even eliminate the complexity and sidelink information overhead typically incurred by these PAPR reduction techniques. Further, it is worth mentioning that these PAPR reduction techniques have also been recently investigated in other non-SCMA based NOMA systems [32]–[35], but these are beyond the scope of this paper.

The contributions of this paper can then be summarized as:

- We highlight the two main factors that impact the PAPR statistics in SCMA-OFDM systems as a result of the dependency between data carrying SCs - the phase bias in the SCMA constellation design and the accompanying resource allocation strategy.
- We show that such a resource allocation based PAPR analysis allows for PAPR gains through the setting of static configuration parameters that does not incur any computational overhead. Such gains are not possible in traditional OFDM systems that individually modulate the SCs.
- Finally, we analyse the class of PAPR reduction techniques based on multiple signalling and probabilistic techniques in the context of SCMA-OFDM systems. We then compare the static PAPR gains from the

resource allocation based strategies with the gains from these well known PAPR reduction techniques and offer some insights into how they can be used together to improve the PAPR while minimizing complexity and throughput loss.

The rest of this paper is organized as follows. Section II describes the uplink SCMA-OFDM system model. Section III provides a detailed comparison between the PAPR analysis in traditional OFDM systems and SCMA-OFDM systems, highlighting the key differences between the two. In particular, Section III-B describes the novel aspects that make the PAPR statistics different in SCMA-OFDM systems. Section IV then describes resource allocation strategies that impact the PAPR statistics and in Section V, we provide simulation results. Section VI examines the PAPR reduction techniques based on multiple signalling in the context of SCMA-OFDM systems. Finally, the conclusion with future research directions is presented in Section VII.

II. SYSTEM MODEL: UPLINK SCMA-OFDM TRANSMISSION

Consider an SCMA-OFDM system where the total bandwidth is comprised of Z OFDM SCs. The Z SCs are uniformly divided into SCMA blocks of size N . Therefore, a total of $N_B = Z/N$ SCMA blocks can be configured in the system. Within one SCMA block, K users share the N SCs such that $N < K$. Due to the sparse overloading of SCMA, each user is assigned to only $d_v \ll N$ SCs. If the SCMA block is fully loaded, each user is assigned a unique combination of d_v SCs and

$$K = \binom{N}{d_v}. \quad (1)$$

In an M -point signal constellation, each $N_M = \log_2 M$ bits for each user is sent over the d_v SCs. A user-to-SC binary allocation matrix \mathbf{S} of dimensions $N \times K$ dictates which d_v SCs are assigned to which users. Every row in \mathbf{S} represents a SC, while every column represents a user. For example, for $N = 4$, $d_v = 2$ and $K = 6$, a sample user-to-SC allocation matrix is

$$\mathbf{S} = \begin{bmatrix} 1 & 0 & 1 & 0 & 1 & 0 \\ 0 & 1 & 1 & 0 & 0 & 1 \\ 1 & 0 & 0 & 1 & 0 & 1 \\ 0 & 1 & 0 & 1 & 1 & 0 \end{bmatrix}. \quad (2)$$

As the first and third positions in the first column of \mathbf{S} in (2) are non-zero, we can say the first user has allocation “1010” in one SCMA block. In other words, user 1 is assigned to the first and the third SCs. Similarly, the second user is assigned the second and fourth SC in the SCMA block, i.e., it has allocation “0101” and so on. Since this is a fully loaded system, all unique combinations of $d_v = 2$ SCs are covered in the K columns of \mathbf{S} .

We consider a modulation symbol to be the representation of $\log_2 M$ bits, e.g., when $M = 4$, the modulation symbols are ‘00’, ‘01’, ‘10’ and ‘11’. Each user can send L ($L \leq N_B$)

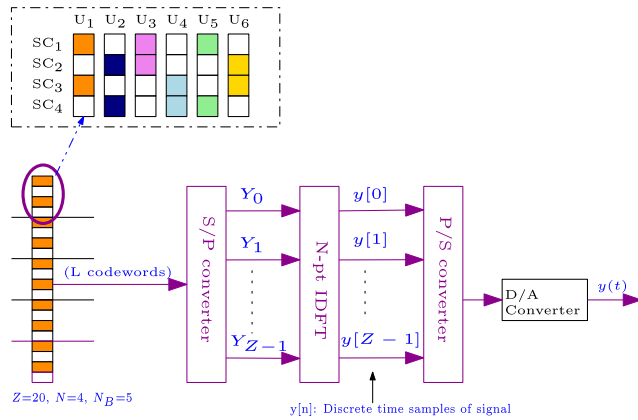

FIGURE 1. The transmitter for User-1 in an SCMA-OFDM system where 6 users share 4 SCs, with 2 non-zero SCs allocated to each user.

modulation symbols over L different SCMA blocks in the same OFDM symbol duration. For simplicity, we assume each user has the same user allocation in each of these L blocks. For instance, for the user-to-SC allocation matrix in (2), user 1 is assigned to the allocation “1010” over all the L blocks.

In an SCMA-OFDM system with K users, each symbol of the k^{th} user is mapped to a d_v -dimensional complex constellation $\mathbf{Q}_k = (\tilde{x}_{1,k}, \dots, \tilde{x}_{d_v,k})^T$, that is selected from the columns of a $d_v \times M$ matrix called \mathbf{X}_k . As in [3], for uplink transmission, we assume that the constellation scheme used is the same for all K users. Hence, when describing the transmitter for one user in an SCMA-OFDM system, the index k can be dropped and the d_v -dimensional SCMA constellation scheme for the user can be represented by \mathbf{X} . Each column represents what the user transmits for the $m = \{1, \dots, M\}$ symbol, i.e., $\mathbf{X} = (\mathbf{x}_1, \dots, \mathbf{x}_M)$ and $\mathbf{x}_m = (x_{1,m}, \dots, x_{d_v,m})^T$.

In an SCMA-OFDM system, the transmitter maps L sets of N_M bits to L modulation symbols, based on \mathbf{X} . These L modulation symbols will be carried over the $L \times d_v$ SCs assigned to it and the user is required to leave the other SCs in the system as null SCs, i.e., the user does not transmit anything on these null SCs. Let Y_i denote the complex constellation point transmitted in SC_i in the system. Y_i will either be null if SC_i is not assigned to the user, or else Y_i will contain $x_j \in \tilde{x}_m, j \in \{1, \dots, d_v\}$, for the symbol m transmitted in SC_i . An inverse fast Fourier transform (IFFT) based implementation of an OFDM transmitter uses the input on these SCs to generate the discrete time domain samples of the signal, $y[n]$, as follows:

$$y[n] = \frac{1}{\sqrt{Z}} \sum_{i=0}^{Z-1} Y_i e^{j2\pi \frac{in}{Z}}. \quad (3)$$

Fig. 1 illustrates an example of the transmitter of an SCMA-OFDM system. In the top-left part of the figure, one SCMA block with $K = 6, N = 4, d_v = 2$ with the user-to-SC allocation matrix \mathbf{S} from (2) is depicted. The users are labelled from U_1 through to U_6 and the SCs from SC_1 through to SC_4 .

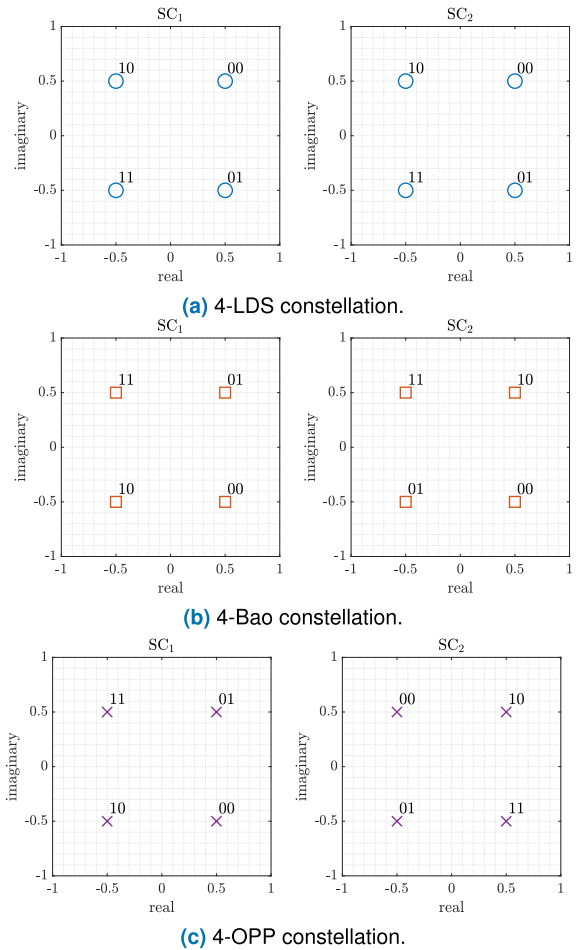

FIGURE 2. The 4-point SCMA constellations used in this study.

The coloured boxes indicate that the corresponding SC is assigned to the user from \mathbf{S} . The IFFT based implementation of the transmitter for U_1 is then illustrated. Since, from (2), U_1 has allocation “1010”, it uses the first and third SC in every SCMA block it transmits on. In this example, U_1 transmits one modulation symbol in each of the available SCMA blocks, i.e., $L = 5$. This corresponds to the user using 5 blocks with 2 SCs in each block, which constitutes a total of 10 SCs.

The M -point SCMA modulation scheme² determines how N_M bits of user data are mapped to the d_v SCs allocated to a user. The known multi-dimensional constellation schemes in the literature are outlined in detail in the survey in [3]. In Fig. 2, we show multi-dimensional SCMA constellation schemes when $M = 4$ and $d_v = 2$. The first two constellations are named 4-LDS and 4-Bao respectively, which follows the same naming convention as the authors in [3] for consistency. The third, named 4-OPP, is a new constellation we will introduce in Section III-B.

²In this paper, we use the terms SCMA modulation scheme and SCMA multi-dimensional constellation interchangeably.

III. PAPR IN TRADITIONAL OFDM SYSTEMS VS. PAPR IN SCMA-OFDM SYSTEMS

In this section, we present the key differences between studying the PAPR in traditional OFDM systems that independently modulate the SCs vs. in an SCMA-OFDM system. As we discussed in the introduction in Section I, the PAPR attained during an OFDM signal transmission is a random quantity that can be analysed in terms of the maximum theoretically attainable PAPR in a given OFDM symbol duration or through a statistical characterization of the PAPR, called the PAPR statistics. In traditional OFDM systems, the maximum theoretically attainable PAPR can be determined through the knowledge of the constellation scheme used to independently modulate each SC, e.g., M -QAM. In SCMA-OFDM systems, the theoretically attainable PAPR can be determined in a similar way but must account for the multi-dimensional constellation scheme in use. However, in the vast body of PAPR literature for OFDM systems, it has been shown that when the number of SCs is sufficiently large, i.e., high-rate users, the maximum theoretically attainable PAPR value occurs with next to negligible probability and the PAPR statistics offer more meaningful insights [8]–[11]. The same is true for an SCMA-OFDM transmitter that transmits over a large number of SCs in the same OFDM symbol duration, i.e., high-rate users. However, the discussion on PAPR statistics for SCMA-OFDM systems is different because of the statistical dependency between SCs. In what follows, we discuss how the combination of the multi-dimensional modulation scheme along with the accompanying resource allocation strategy impacts the PAPR statistics in such high-rate SCMA-OFDM systems.

A. PAPR IN OFDM SYSTEMS

An OFDM signal, $y(t)$, that is generated from individually modulated subcarriers transmitted in the same OFDM symbol duration can be represented as

$$\begin{aligned} y(t) &= \sum_{k=0}^{Z-1} a_k \exp(j2\pi(f_c + k\Delta f)t) \\ &= \exp(j2\pi f_c t) \sum_{k=0}^{Z-1} a_k \exp(j2\pi kt/T_s), \end{aligned} \quad (4)$$

where a_k is the complex-valued constellation point transmitted in SC k , f_c is the centre frequency of SC k and Z is the total number of SCs in the system. If $y(t)$ is sampled at a rate of Z/T_s , i.e., every sample is taken at multiples of T_s/Z , the discrete time version for the baseband part of $y(t)$ from (4) can be expressed as

$$y[n] = \sum_{k=0}^{Z-1} a_k \exp(j2\pi kn/Z). \quad (5)$$

When the transmitted OFDM signal is generated from independently modulated SCs, the non-constant envelope creates large instantaneous peaks in the signal. These power peaks occur when the individual signals align in phase, which

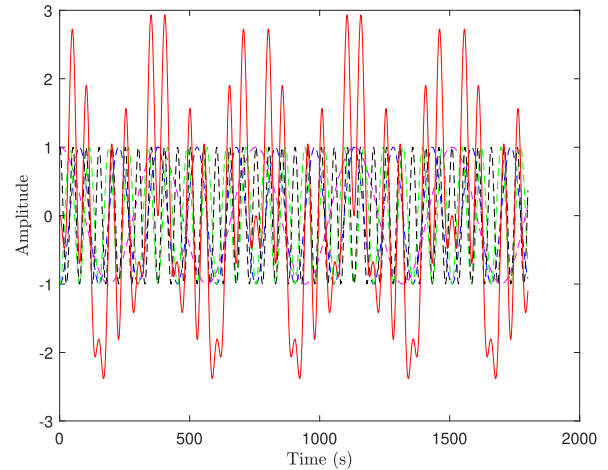

FIGURE 3. Illustration of the power peaks produced when summing sinusoids of evenly spaced frequencies as is the case in an OFDM signal.

can be much larger than the average power of the transmitted signal and results in a high PAPR. This is illustrated in Fig. 3, where four sinusoids with equal subcarrier spacing are added together and the resultant signal has large power peaks. While PAPR applies to the continuous time transmitted signal, studies have shown that if over-sampled with a sufficiently high ratio [36], PAPR can be accurately calculated from the discrete time samples $y[n]$ from (5) as follows:

$$\text{PAPR (dB)} = 10 \log_{10} \left(\frac{\max(|y[n]|^2)}{\mathbb{E}(|y[n]|^2)} \right). \quad (6)$$

The PAPR attained is a random quantity, since it depends on the sequence of complex-valued constellation points transmitted in the Z SCs along with the symbol rate. If a_k is selected from a QAM constellation of M points of equal magnitude, e.g., 4-QAM, then the maximum theoretically attainable PAPR is Z [10]. This is because when all the SCs add coherently, the instantaneous power is Z^2 , while the average power to transmit Z SCs of unit energy signals each is Z . However, it has been shown that when Z is sufficiently large, this theoretically attainable PAPR value occurs with negligible probability and the PAPR statistics offer more meaningful insights [8]–[11]. For example, with $Z = 32$, 4-ary modulation and an OFDM symbol duration of $100 \mu\text{s}$, the authors in [9] showed that the theoretically attainable PAPR occurs every 3.7 million years. For an OFDM system with Z SCs, M^Z unique symbol sequences and thus M^Z unique OFDM waveforms per block can be generated [8]. Some of these waveforms will have low PAPR and some will have a higher PAPR value. Since traditional OFDM systems typically involve independently modulated SCs, the PAPR statistics have been characterized with this assumption in several studies [9], [11], [12]. Since the Z SCs are individually modulated, and if Z is large, the central limit theorem dictates that the real and imaginary parts of the transmitted OFDM signal can be modelled by Gaussian random processes. As a

result, the overall envelope of the transmitted signal follows a Rayleigh distribution [11].

B. PAPR IN SCMA-OFDM SYSTEMS

When L modulation symbols, carried over L SCMA blocks, are transmitted in the same OFDM symbol duration, the maximum theoretically attainable PAPR of the transmitted signal can be computed from (6). Let $X_{m,\max}$ denote the maximum possible instantaneous peak to transmit symbol m . Thus, $X_{m,\max}$ is the sum of the amplitudes of all d_v dimensions of \mathbf{x}_m . Let X_{\max} denote the maximum possible instantaneous peak from the constellation scheme, i.e., the peak which occurs when the modulation symbol that contains the maximum peak is transmitted. The maximum attainable peak from transmitting L symbols is achieved when the symbol corresponding to X_{\max} is transmitted on all SCMA blocks and each of the SCs line up in phase. Also, let $P_{X,m}$ represent the power required to transmit \mathbf{x}_m and $P_{X,\text{avg}}$ represent the average power of transmitting a symbol from the constellation. The maximum possible PAPR value, calculated per OFDM symbol duration, is computed as follows:

$$\text{PAPR (dB)} = 10 \log_{10} \left(\frac{|L \times X_{\max}|^2}{L \times P_{X,\text{avg}}} \right), \quad (7)$$

where

$$\begin{aligned} X_{m,\max} &= \sum_{i=1}^{d_v} x_{i,m}, \quad \forall m \in \{1..M\} \\ X_{\max} &= \max(X_{m,\max}) \\ P_{X,\text{avg}} &= \frac{\sum_{m=1}^M \sum_{i=1}^{d_v} x_{i,m}^2}{M}. \end{aligned}$$

If $L = 1$, we can consider that as the constellation PAPR. It is clear that this constellation PAPR value is determined entirely from the design of the SCMA multi-dimensional constellation. For example, for the constellation schemes shown in Fig. 2, $X_{\max} = 1.4$, $P_{X,\text{avg}} = 1$ and so the constellation PAPR is 3.04 dB. In this context, codebook designs that minimize this theoretically attainable PAPR have been proposed [19]–[22]. For example, in [19], a low-PAPR codebook that minimizes the number of projections, i.e., non-zero dimensions in the constellation scheme, is proposed. If a zero dB PAPR constellation design is required, i.e., 0 dB constellation PAPR when $L = 1$, then each modulation symbol should be coded with the same amplitude on only one of the d_v SCs. The constellation design approach for this is outlined in Appendix A.

We described in Section III-A that for traditional OFDM systems, when the number of modulated SCs is large, the theoretically attainable PAPR occurs with negligible probability and the PAPR statistics are more meaningful to study. An SCMA-OFDM user transmits L modulation symbols per OFDM symbol duration over $L \times d_v$ SCs. Hence, when L is large, the PAPR statistics become more meaningful to study in an SCMA-OFDM system. Since L corresponds to the number of modulation symbols transmitted per OFDM

symbol duration, we can equate a large value of L with high-rate users. Hence, the PAPR statistics should be investigated for such high-rate users. The SCMA codebook influences the PAPR statistics in ways that are different from the PAPR perspective studied in SCMA systems for low-rate users in [19]–[22]. Further, the characterization of the PAPR statistics is different from traditional OFDM systems for the reasons we discuss next.

The PAPR statistics in SCMA-OFDM systems are different from traditional OFDM systems because of two main factors. Firstly, the presence of null SCs in the codebooks means that each user transmits on only a small fraction of the total available SCs. Secondly, the data carrying SCs are not independently modulated. One modulation symbol dictates what is transmitted in d_v SCs. Hence, these d_v SCs are dependent in the statistical sense. As we discussed in the system model in Section II, it is the multi-dimensional constellation used in the SCMA codebook that determines what the user transmits on each of the d_v SCs. This creates a statistical dependency between these d_v SCs, since they are collectively determined by the choice of one modulation symbol. This dependency affects the PAPR statistics through the level of *phase bias* in the constellation design. To illustrate this concept of *phase bias* in an SCMA multi-dimensional constellation, we use two of the known multi-dimensional constellations from the SCMA literature when $M = 4$ and $d_v = 2$, named 4-LDS and 4-Bao respectively [3]. To these, we introduce another SCMA constellation, namely 4-OPP. These three constellations are depicted in Fig. 2 and all have the same constellation points in each dimension, but are combined differently to form the codewords for the respective modulation symbols. The 4-LDS scheme repeats the same constellation point over all the dimensions in which they are coded. This means that all the SCs carrying an LDS modulation symbol are guaranteed to have the same phase. In 4-Bao, two symbols, “00” and “11”, are coded with the same point in both SCs (i.e., same phase), while the other two symbols, “01” and “10”, are coded with constellation points of exactly opposite phase. This means if the symbols “00” and “11” are transmitted, a phase bias of having two SCs with the same phase guaranteed will occur. On the other hand, when “01” and “10” are transmitted, the opposite bias is introduced. Given each of the four symbols are equally likely to be transmitted, we can expect these two opposing bias effects to statistically cancel each other out. 4-OPP on the other hand has the opposite effect of LDS and introduces a guaranteed 180° phase difference between the two constellation points for each and every symbol.

The impact that such a phase bias in the constellation scheme has on the PAPR statistics comes from the a-priori statistical dependency it introduces between transmitted SCs in the same OFDM symbol. This is a feature that is very different from traditional OFDM systems where the SCs are independently modulated. However, whether the phase bias has a positive or negative effect on the PAPR statistics compared to independently modulating the SCs is influenced by

whether these dependent SCs are of similar or very different centre frequencies in the spectrum. For example, when 4-LDS with the phase bias of having constellation points all of the same phase is transmitted over d_v , statistically dependent SCs that are near contiguous in the spectrum, it will have a detrimental effect on the PAPR statistics. Alternatively, when 4-OPP that contains a phase bias of having constellation points of exactly opposite phases is transmitted over contiguous SCs, it is likely to have a positive effect on the PAPR statistics. These are just a simple consequence of the way the signals in OFDM SCs add up to form the equivalent OFDM signal, as illustrated earlier in Fig. 3. However, the SCs carrying SCMA codewords do not necessarily have to be contiguous SCs. It depends on which SCs are allocated to the SCMA blocks assigned to the user. Hence, we refer to this as the SC allocation or resource allocation strategy. In what follows, we first describe different resource allocation strategies that could impact the PAPR statistics in Section IV and then analyze the joint impact of the phase bias in the constellation design and the accompanying SC allocation strategy on the PAPR statistics in Section V.

IV. RESOURCE ALLOCATION SCHEMES

As we discussed in Section III-B, the placement of the dependent SCs in an SCMA-OFDM system influences the PAPR statistics. The placement of the dependent SCs is determined by how the SCs in the spectrum are assigned to carry the SCMA blocks, i.e., the resource allocation strategy. While any number of such resource allocation strategies can be considered, we focus on two resource allocations which represent the two extremes in terms of frequency separation, i.e., the spacing between the dependent SCs. In the illustration shown in the system model in Fig. 1, every N contiguous SCs is grouped into an SCMA block. We term this as the *regular allocation*. However, if the grouping of every N consecutive SCs to form an SCMA block is considered as a virtual view of the system SCs, it can be mapped in any way to the physical OFDM SCs. In the second resource allocation strategy, we separate the individual SCs that make up an SCMA block by as much as possible. Since separating the SCs that carry the SCMA codeword equates to providing frequency diversity between the d_v SCs, we call this the *diversity allocation*. An illustration of this mapping for a system with 16 SCs is shown in Fig. 4. The virtual allocation, depicted as va in the figure, is the same as the regular allocation. The physical allocation, represented as pa in the figure, represents the diversity allocation. The algorithm for constructing this diversity allocation is discussed next.

A. CONSTRUCTING THE DIVERSITY ALLOCATION SCHEME

Attaining frequency diversity translates to providing as much separation as possible between the non-zero dimensions over which an SCMA modulation symbol is transmitted. Since every pair of SCs in an SCMA block belong to some user's allocation in user-to-SC allocation matrix \mathbf{S} as shown in (2),

SC's in the system:

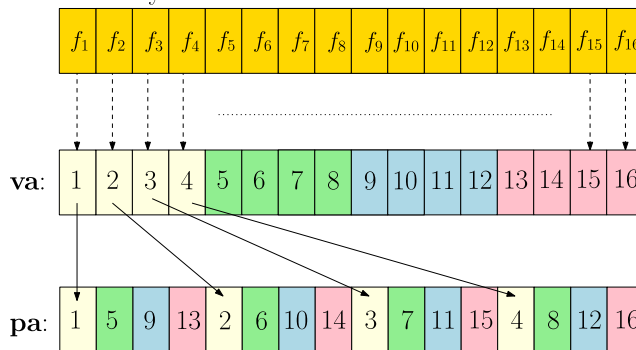

FIGURE 4. Illustration of the diversity allocation mapping from the virtual view of SCMA blocks (also the regular allocation) to the physical OFDM SCs.

we seek some guaranteed minimum level of separation between every pair of SCs that belong to an SCMA block.

Let the OFDM SCs in the system be indexed as $\{f_1, f_2, \dots, f_Z\}$, with the SC spacing between any two SCs denoted by Δf . If $\{f_1, \dots, f_N\}$ constitutes the first SCMA block, $\{f_{N+1}, \dots, f_{2N+1}\}$ constitutes the second SCMA block and so on, it is termed as the “regular allocation”. On the other hand, in the diversity SC allocation scheme, we distribute N SCs to each SCMA block such that there is a minimum number of SCs that separate any pair of SCs in an SCMA block. In order to define this diversity allocation scheme, we will treat the regular allocation as the virtual allocation of SCs to SCMA blocks and define a mapping from the virtual allocation to the physical allocation of SCs in the system. We thus define two Z -dimensional vectors, \mathbf{va} and \mathbf{pa} , to represent the virtual and physical allocation of SCs in the system, respectively. The goal of this diversity scheme is to provide a mapping from $\mathbf{va} \rightarrow \mathbf{pa}$ such that in the \mathbf{pa} vector, every pair of SCs in an SCMA block is separated by at least a certain number of SCs. An example of this mapping was illustrated in Fig. 4 for a system with $Z = 16$ and $N = 4$.

We first seek to concretely determine this minimum level of SC separation that can be attained. Let μ represent the minimum number of SCs that separate any pair of SCs in an SCMA block. The number of SCMA blocks is $N_B = Z/N$. If the first SC in every block from \mathbf{va} is mapped contiguously to the first available index in \mathbf{pa} , the last block starts at index N_B . For the example in Fig. 4, indexes $\{1, 5, 9, 13\}$ represent the first index of each block in the virtual allocation, which are placed contiguously at the start of the physical allocation. Clearly, the first index of the last block, i.e., index 13 from \mathbf{va} , gets placed at index $N_B = 4$ in \mathbf{pa} . The last available SC index in the system is Z , so μ_{max} for the remaining $(N - 1)$ SCs in each SCMA block will be such that they are equally spread apart and can be determined as

$$\frac{Z}{N} + (N - 1)\mu_{max} = Z. \tag{8}$$

Solving (8), we get $\mu_{max} = Z/N = N_B$, which is the maximum amount of SC spacing we can guarantee to any

pair of SCs in every SCMA block in the system. Algorithm 1 then describes the mapping from $\mathbf{va} \rightarrow \mathbf{pa}$ such that in the \mathbf{pa} vector, every pair of SCs in an SCMA block is separated by at least μ_{max} SCs.

Algorithm 1: Proposed Diversity-Based SC Mapping

Input : $\mathbf{va} \rightarrow$ a size Z vector representing the virtual allocation where every N consecutive entities represent an SCMA block

Output: $\mathbf{pa} \rightarrow$ a size Z vector representing the physical allocation of SCs, where at least Z/N SCs separate the entities of an SCMA block.

initialize $\mathbf{pa} \leftarrow \infty$ (all elements);

for $i \leftarrow 1$ to Z do

 if $i \bmod N = 1$ then

 for $j \leftarrow 1$ to (Z/N) do

 if $\mathbf{pa}(j) \neq \infty$ then

$\mathbf{pa}(j) \leftarrow \mathbf{va}(i)$;

 break;

 else

$n \leftarrow i \bmod N$

 if $n = 0$ then

$n \leftarrow N$

$\mathbf{pa}(j + n * (Z/N)) \leftarrow \mathbf{va}(i)$

The algorithm iterates through each of the SCs in \mathbf{va} but operates on an SCMA block by SCMA block basis. When it detects the start of a new SCMA block in \mathbf{va} , it takes the first SC in the block and assigns it to the smallest available index in \mathbf{pa} . Every subsequent SC in the block from \mathbf{va} is then placed μ_{max} SCs apart. This is done for all the N_B blocks in the system. For example, if $Z = 128$ and $K = 4$, then $\mu_{max} = 32$. The algorithm starts from \mathbf{va}_1 which is assigned to \mathbf{pa}_1 . The SC in \mathbf{va}_2 will then be placed 32 SCs apart at \mathbf{pa}_{33} . Similarly, allocations $\mathbf{va}_3 \rightarrow \mathbf{pa}_{65}$ and $\mathbf{va}_4 \rightarrow \mathbf{pa}_{97}$ are made. Now, \mathbf{va}_5 represents the start of a new SCMA block and is hence assigned to \mathbf{pa}_2 , the smallest available index since \mathbf{pa}_1 is used. Again, the remaining SCs in this block are placed 32 SCs apart starting from index 2 and the process repeats for the remaining blocks. The final SCMA block will have its first SC placed at \mathbf{pa}_{32} and final SC at the last available index at \mathbf{pa}_{128} .

Returning to the example in Fig. 4, it also depicts how different users get a different level of SC separation depending on their user allocation, from the user-to-SC matrix in (2). A user with allocation “1100” has a spacing of four SCs between the coded dimensions while the user with allocation “1001” gets a much larger separation of twelve SCs. However, all users are assured a separation of at least μ_{max} between their coded dimensions.

V. SIMULATION RESULTS

We describe the joint impact of the SCMA constellation design and SC allocation on the PAPR statistics of high-rate

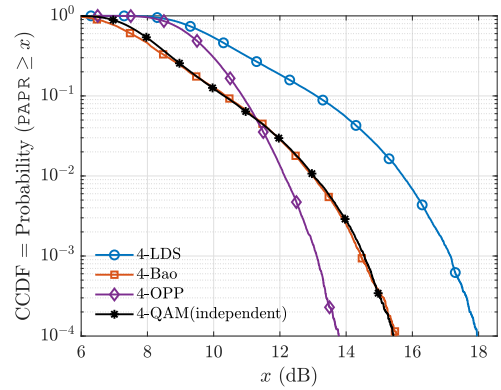

(a) Regular SC allocation scheme, user allocation = “0011”.

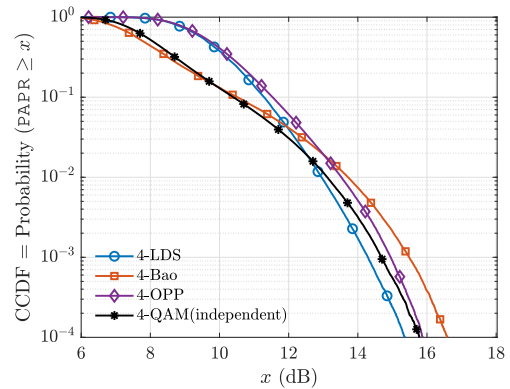

(b) Diversity SC allocation scheme, user allocation = “0011”.

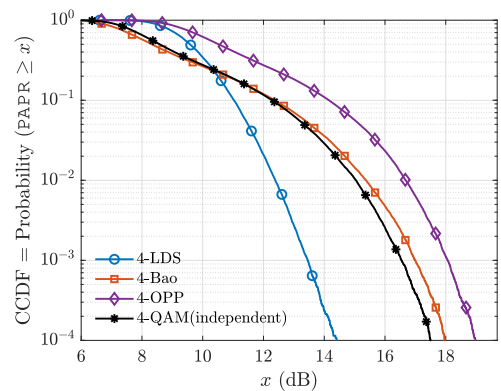

(c) Diversity SC allocation scheme, user allocation = “1001”.

FIGURE 5. Comparing 4-LDS, 4-Bao and 4-OPP with different SC allocation schemes. For illustration, the curve when independent 4-QAM symbols (non-SCMA symbols) are transmitted in the same data carrying SCs is included.

users with the help of the MATLAB simulations presented in Fig. 5. All experiments were run for a large number of OFDM symbols, in the order of 10^4 . The total number of SCs in the system, $Z = 128$, are divided into $N_B = 32$ SCMA blocks of $N = 4$ SCs each with $L = 32$. Also included in the results in Fig. 5 is a simulation run for randomly generated independent 4-QAM constellation points transmitted only on the data carrying SCs assigned to the user under test from

the user-to-SC allocation matrix \mathbf{S} in (2). Note that this is different from 4-LDS, because the SCs are being individually modulated. We illustrate the regular scheme for the user with allocation “0011” from matrix \mathbf{S} , while the diversity scheme for the users with allocations “1001” and “0011” for the reasons we outline next.

Since each user is allocated a different set of d_v SCs per SCMA block to transmit on (defined from matrix \mathbf{S}), the PAPR statistics of each user will not necessarily be the same. With the regular scheme, in our illustration, an SCMA block is comprised of $N = 4$ contiguous SCs. Hence, any combination of $d_v = 2$ SCs comprises SCs of similar centre frequencies. Thus, any one of the possible user allocations, e.g., “0011”, is representative of the PAPR performance for all users. On the other hand, with the diversity scheme, different user allocations experience different levels of frequency separation. For instance, referring to the example in Fig. 4, the user with allocation “1001” has the first and fourth SC in the virtual allocation which are separated the furthest, while the user with “0011” has the third and fourth SC in the virtual allocation which is separated the least. Thus, the user with allocation “1001” represents the maximum SC separation scenario while “0011” corresponds to the user having the minimum SC separation.

We see from the results in Fig. 5 that with the regular allocation scheme, 4-OPP outperforms 4-LDS. With 4-OPP, we are placing $d_v = 2$ constellation points of equal magnitude but opposite phase in two near-contiguous SCs. While with LDS, we have the guaranteed placement of two points with the same amplitude and same phase in near contiguous SCs, i.e., SCs of similar centre frequencies. The sum of two sinusoids of similar frequencies will line up for higher peaks if they start at the same phase. However, with the diversity scheme, we see the trend shifts. With the “0011” allocation that provides the minimum frequency separation, we start to see 4-LDS and 4-OPP behave similarly, while with the maximum separation “1001” user allocation, the results are the exact opposite of the regular scheme. Increasing the SC separation between the d_v SCs, means that we are adding sinusoids of increasingly different frequencies to generate the OFDM signal. As the frequency separation becomes large enough, the simulations show the modulation scheme biased to have both dimensions start at the same phase, i.e., 4-LDS, generates better PAPR statistics.

The complete change in the order from Fig. 5a to Fig. 5c highlights why it is important to study the PAPR statistics as the joint effect of the SCMA modulation scheme and the corresponding SC allocation strategy. Hence, when comparing the PAPR performance of different SCMA modulation schemes from the literature [3], it is not sufficient to conclude that one scheme outperforms the other. The modulation schemes have to be analyzed in conjunction with the associated SC allocation strategy to fully understand their impact on the PAPR statistics. Since the modulation scheme is a physical layer design parameter while the SC allocation comes from the layer-2 resource allocation strategy, the PAPR

problem for high-rate users in SCMA-OFDM systems should be studied as a cross-layer systematization problem. As we showed in Section III-B, this is in contrast to the low-rate users with a small value of L where it is sufficient to analyse the PAPR purely from the layer-1 perspective of the SCMA multi-dimensional constellation design.

Further, as seen in Fig. 5, with each SC allocation, 4-Bao performs similar to just placing random 4-QAM points in the data carrying SCs. This is because it contains an equal mix of same and opposite phase bias among its constellation points, so the PAPR statistics reflect that it is no different from independently modulating the data carrying SCs. However, the SCMA codebook still plays an important role in the PAPR statistics for this 4-Bao scheme, even though there is no phase bias in the constellation. That is because only a subset of the SCs are being modulated with data carrying complex constellation points and the SC allocation strategy determines which are the data carrying SCs and which are the null SCs. As we can see, there is a nearly 3 dB performance difference between 4-Bao with regular scheme and the diversity scheme for “1001” allocation in Fig. 5a and Fig. 5c, respectively. From the existing PAPR literature on OFDM systems, it is known that swapping the location of data carrying and reserved null SCs can lead to significant PAPR reduction [37], [38]. It is the same observation we make here, except that the null SCs are determined by the SCMA codebook and the associated SC placement strategy. This highlights the fact that we can attain a better PAPR performance for any SCMA constellation through the SC placement strategy.

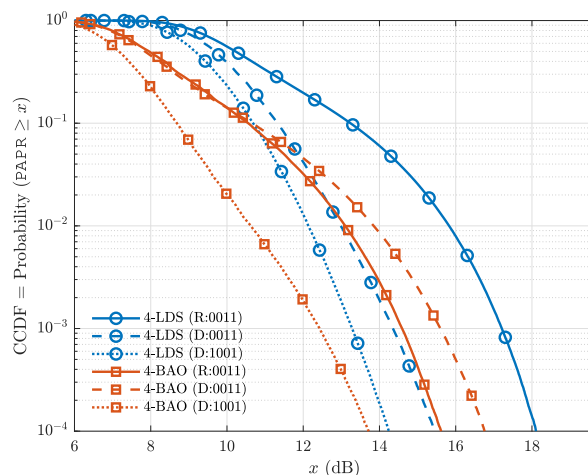

FIGURE 6. Comparing the PAPR statistics with different choices of SCMA modulation schemes and SC allocation strategies. These options are static configuration parameters that impact the PAPR statistics in SCMA-OFDM systems.

It is clear from the results in Fig. 5 that we should adopt a SC allocation strategy that shuffles around the SCs if we have a modulation scheme with the phase bias of having constellation points of the same phase, while we should use a contiguous SC allocation strategy for a scheme that has a

phase bias of having constellation points of opposite phase. For the 4-LDS and 4-Bao schemes, which are schemes from the existing SCMA literature, we summarize the observations for these constellations in Fig. 6. We see that for a desired SCMA scheme, an appropriate SC allocation strategy based on the phase bias in the chosen SCMA scheme can be selected to reduce the PAPR or even vice-versa, i.e., for a desired SC allocation strategy, an SCMA scheme with favourable phase bias characteristics to reduce the PAPR can be selected. These results are important because the PAPR gains achieved between different configurations are a result of static configuration parameters, i.e., they are configured one-time on setup and come with no additional computational overhead. This is made possible by the SCMA codebook that introduces dependency between the transmitted SCs in the system. These statistical dependencies can be exploited to achieve PAPR reduction in a static manner, not possible in traditional OFDM systems that individually modulate the SCs. We discuss these opportunities for PAPR reduction in detail next in Section VI.

VI. EXPLOITING STATISTICAL DEPENDENCY IN PAPR REDUCTION SCHEMES BASED ON MULTIPLE SIGNALLING

In this section, we investigate how the novel aspects to the analysis of PAPR statistics in SCMA-OFDM systems, discussed in Section III-B, impact the class of PAPR reduction techniques based on multiple signalling and probabilistic techniques [6]. The general idea with these PAPR reduction techniques is to generate a set of candidate signals every OFDM symbol and transmit the signal with the least PAPR. These techniques are information lossless, since they do not distort the transmitted signal. However, they come with the complexity overhead of generating the set of candidate signals every OFDM symbol as opposed to just one signal. They also incur a throughput loss due to the need to transmit sidelink information, not ideal for overloaded NOMA systems. When these PAPR reduction techniques are used in traditional OFDM systems, since each SC is independently modulated, there is no advance knowledge of any statistical dependencies between the SCs to exploit. Hence, the set of candidate signals can only be generated after the information sequence in that OFDM symbol is known. However, with SCMA-OFDM systems, the statistical dependency between the transmitted SCs can be exploited for PAPR reduction in conjunction with these well established techniques. We show that for a given level of PAPR reduction, the overhead incurred by these multiple signalling techniques can be reduced or even eliminated in some scenarios.

The PAPR reduction techniques described in [6] under the class of multiple signalling and probabilistic techniques all assume that the SCs in the system are independently modulated with QAM symbols. With SCMA-OFDM systems, some of these techniques can be applied with some modifications to satisfy the SCMA constraints while some techniques cannot be easily extended to the SCMA-OFDM paradigm. For example, techniques that involve constellation shaping [29], [30] or tone injection cannot easily lend itself to SCMA

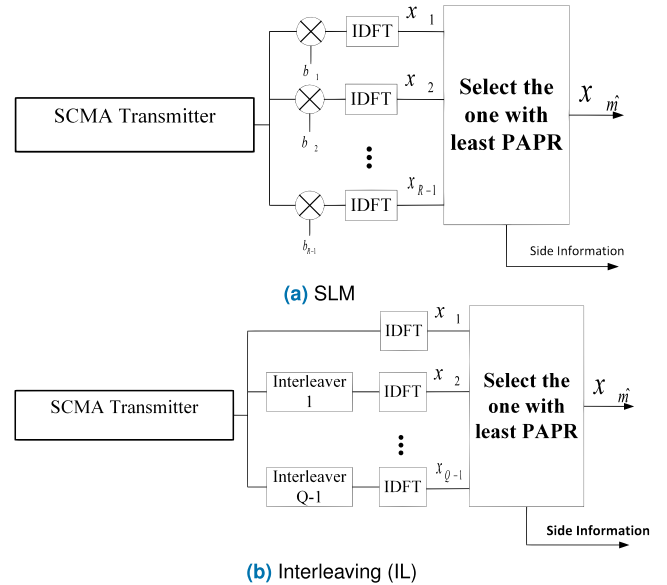

FIGURE 7. Block diagrams highlighting the PAPR reduction techniques of SLM and IL that are described in the context of SCMA-OFDM systems.

systems because it affects the SCMA constellation design. SCMA constellations are designed with a number of criteria [3] that will be affected by the constellation shaping and is beyond the scope of the discussion here. Similarly, techniques that involve using null SCs such as tone reservation [39] or the dynamic swapping of data and null SCs [37], [38] is difficult to extend to the SCMA-OFDM paradigm. This is because the null SCs are an integral part of every SCMA block and cannot be rearranged randomly for PAPR reduction purposes. However, other multiple signalling techniques such as selective mapping (SLM) [27], partial transmit sequences (PTS) [31] and interleaving (IL) [28] can be tailored to meet the constraints of an SCMA-OFDM system. The block diagrams for these three techniques are depicted in Fig.7 and in the discussion that follows, we focus on how they can be adapted to SCMA-based systems.

In the SLM technique used in traditional OFDM systems, a set of candidate OFDM symbols are generated that represent exactly the same information. The signal with the least PAPR is then transmitted. The set of candidate signals is generated by multiplying the original data carried in the SCs for that symbol with R different sets of phase factors

$$b_m = [b_m^0 b_m^1 \dots b_m^{Z-1}], \quad 0 \leq m \leq R - 1, \quad (9)$$

$$b_m^n = e^{j\theta_m^n}, \quad 0 \leq n \leq Z - 1. \quad (10)$$

After the inverse discrete Fourier transform (IDFT) block, this multiplication generates R sequences in time domain and the one with the least PAPR is transmitted. Sidelink information about the phase factor is sent to the receiver to indicate which set of phase sequences were used, so that the receiver can undo the multiplication and regenerate the original data. The side link information is $\log_2 R$ bits long, since we only have to identify which sequence was used. The set of possible sequences are known to both the transmitter

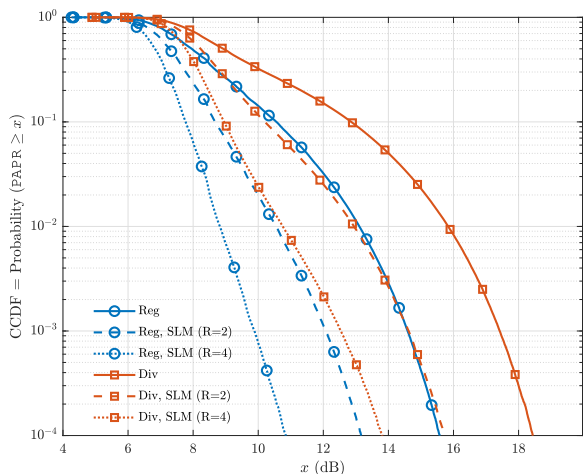

FIGURE 8. Comparing the PAPR reduction achieved with SLM in an SCMA-OFDM system with 4-Bao constellation and different SC allocation strategies and different values of R for the SLM reduction.

and receiver. Additionally, there is significant complexity introduced by the extra IDFT operations every symbol that scales linearly with R [6].

SLM can be applied to SCMA-OFDM systems because the typical SCMA constellation design process used in the literature allows for random user-specific rotations to be performed without affecting the error rate performance in the uplink [3]. While it is a sub-optimal approach to SCMA constellation design to find the mother constellation and user-specific rotations separately, it is by far the most widely used approach in the literature [3]. Further, as shown in [3], in the uplink, the user-specific rotations designed as part of the constellation design process lose meaning due to the fact that different users experience different fading channels. As a result, the user-specific rotations in the UL SCMA systems can be designed for PAPR reduction purposes instead. These random user specific rotations translate to a random phase being multiplied to the d_v dimensions of the SCMA codeword. However, the d_v dimensions of the SCMA codeword cannot each be multiplied by their own phase factor, as doing so would destruct the SCMA. Hence, this additional constraint needs to be placed when generating the set of phase factors that make up the phase sequences. In other words, the set of candidate phase sequences should be generated such that each set of d_v SCs is assigned a phase factor, rather than each SC being assigned its own phase factor. The set of phase sequences generated for a Z -SC OFDM system in (10) needs to then be modified to only generate a list of L phase factors. These phase factors are multiplied by the original data sequence to generate a set of R different OFDM symbols, $y_m, \forall m = 0, \dots, R - 1$, and the signal with the least PAPR is transmitted as follows:

$$y_{\hat{m}} = \underset{m}{\operatorname{arg\,min}} \operatorname{PAPR}(y_m), \quad 0 \leq m \leq R - 1. \quad (11)$$

In Fig. 8, we run MATLAB simulations for the 4-Bao scheme with both the regular and diversity-based SC allocation schemes. We run with $R = 2$ and $R = 4$, which

corresponds to one and two bits of additional sidelink information respectively. With $M = 4$, that corresponds to one SCMA block of transmission reserved for sidelink information. This means there is a throughput loss from L to $L - 1$ modulation symbols per OFDM symbol duration. Additionally, there is a computational complexity overhead that is higher when $R = 4$ compared to when $R = 2$. We can see that for this 4-Bao SCMA constellation, the PAPR reduction achieved with $R = 2$ for the diversity scheme is the same as that achieved with no PAPR reduction using the regular allocation. Similarly, the PAPR reduction achieved with $R = 4$ in the diversity scheme is achieved with $R = 2$ using the regular scheme. The key takeaway message here is that the statistical dependency introduced by the SCMA codebook between certain SCs transmitted in an OFDM symbol can be exploited to achieve PAPR reduction gains through the setting of static configuration parameters such as the SCMA constellation scheme, SC allocation strategy, SCMA block dimensions like N and d_v etc. Such gains are not possible in traditional OFDM systems where the SCs are independently modulated and so there is no advance knowledge of the statistics to exploit.

Another multiple signalling technique called partial transmit sequences (PTS) follows a similar idea to SLM. In PTS, the Z SCs are divided into disjoint sub-blocks and the IDFT of each block is taken. Different phase factors are multiplied to these IDFT outputs, i.e., to the time-domain data, and once again the OFDM signal with the least PAPR is transmitted. When applied to SCMA-OFDM systems, as long as every d_v SCs that make up an SCMA block are contained in the same sub-block, none of the SCMA related constraints are violated. Hence, a logical split for these disjoint sub-blocks would be along the SCMA blocks. The computational overhead involved to generate the candidate signals scales with the number of sub-blocks and is larger than that incurred with SLM [6]. Like with SLM, there is also the sidelink information required which results in a throughput penalty.

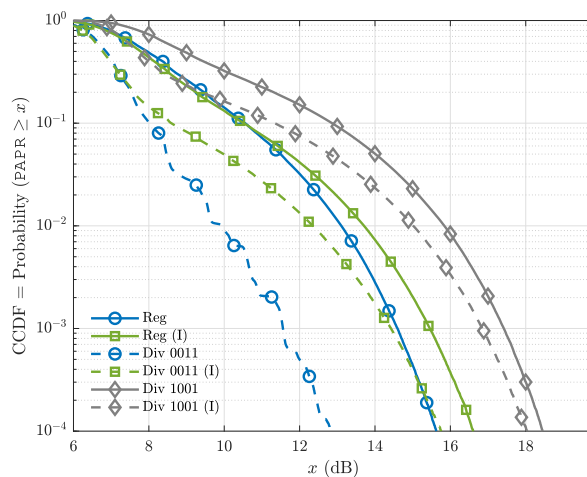

FIGURE 9. Comparing the PAPR reduction achieved with interleaving in an SCMA-OFDM system with 4-Bao constellation and different SC allocation strategies.

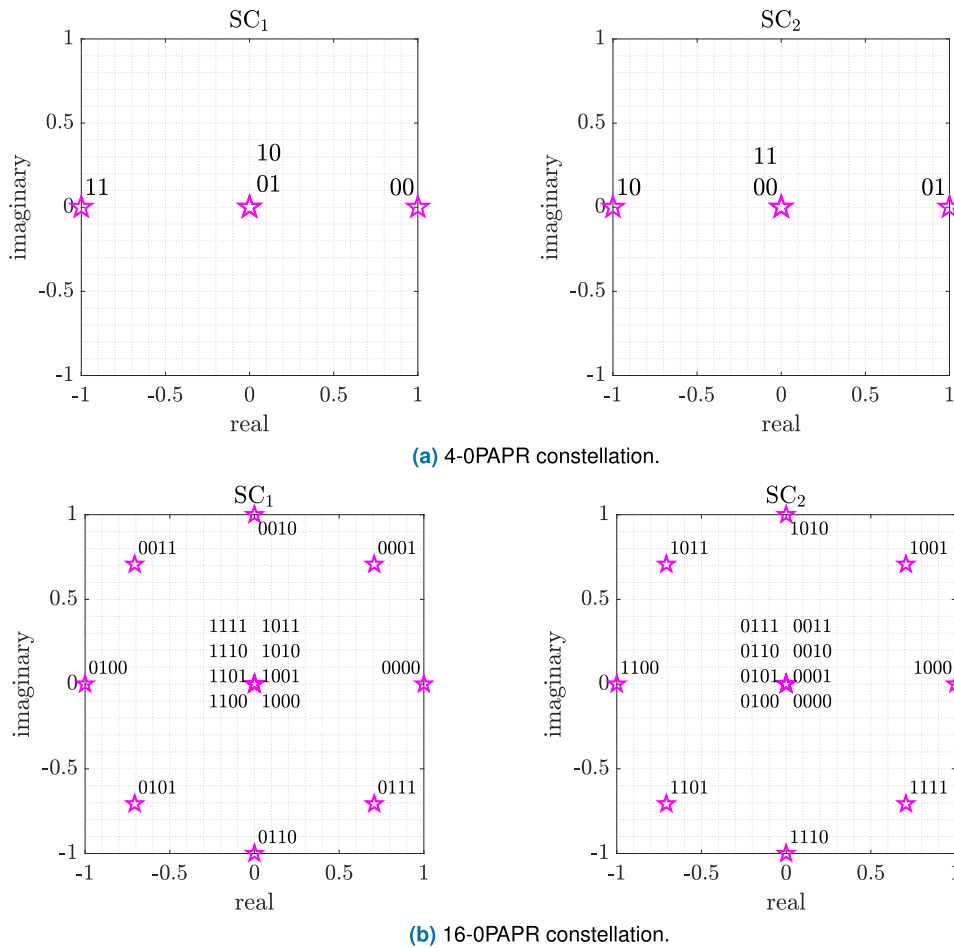

FIGURE 10. Proposed M-OPAPR scheme that has zero dB constellation PAPR.

Simulation results for PTS are not shown here as they are very similar to the observations from SLM, where the static configuration gains from the choice of SC allocation strategy compares with the PAPR reduction gains from PTS when R is small.

Interleaving is another probabilistic technique for PAPR reduction commonly used in OFDM systems. In interleaving, the idea is once again to create a set of data block candidates and select the block with the least PAPR to transmit. Compared to SLM, in this method, an interleaver block is used instead of phase sequences. Interleaver is a device which reorders the entries of a block of length Z in a specific order. Similar to SLM and PTS, there is overhead in computing the IFFT of the different interleaved sequences and also the receiver needs sidelink information to de-interleave the received data block. When applied to SCMA-OFDM systems, we can only interleave the L modulation symbols with each other. In other words, there are L modulation symbols to be transmitted in an OFDM symbol, and they can be transmitted on any of the L SCMA blocks. However, the d_v SCs within a block that contains the codeword for a modulation symbol must remain within the same SCMA block and the interleaver

cannot reorder these SCs. With these constraints, even after applying an interleaver block, the PAPR statistics are still subject to the joint effect of the modulation scheme phase bias and SC placement that was described in Section III-B. This is illustrated by the simulation results in Fig. 9 where the gains attained by interleaving in some configurations are small and do not compare with the PAPR reduction gains from interleaving in traditional OFDM literature [28].

VII. CONCLUSION AND FUTURE WORK

In this paper, we showed that optimizing the SCMA codebook design to just have a low constellation PAPR, for example through low-projection codebooks, is only applicable for low-rate users. For high-rate UL SCMA-OFDM users, the PAPR statistics should be considered. Unlike traditional OFDM systems that independently modulate the SCs, the SCMA construct adds a level of statistical dependency between the transmitted OFDM SC's, which impacts the PAPR statistics. We showed that the PAPR statistics of SCMA-OFDM systems are influenced by the joint impact of the phase bias in the multi-dimensional modulation scheme and the placement of the SCs that carry the SCMA codewords. These two factors

were controlled through the choice of static configuration parameters, namely the SCMA modulation scheme and the SC allocation strategy. This allows for PAPR reduction opportunities without incurring computational overhead. PAPR reduction techniques based on multiple signalling were investigated in the context of SCMA-OFDM systems. We showed that techniques such as SLM, PTS and IL can be adapted to SCMA-OFDM systems with certain modifications. However, the complexity and sidelink information overhead can be reduced by first tuning the static configuration parameters to be favourable to a low PAPR.

In future work, the statistical dependencies between the transmitted SCs in an SCMA-OFDM system can be further characterized. For example, a metric to capture the level of phase bias in an SCMA-OFDM constellation can be derived. In this way, the SCMA constellation design process can aim to maximize this metric, in order to be exploited later with the appropriate SC allocation scheme for PAPR reduction. Further, the impact of the SCMA configuration parameters like d_v and N can be studied. We would expect the level of statistical dependency to grow as d_v increases. PAPR reduction techniques like SLM and PTS can also be enhanced to exploit these statistical dependencies. For small values of L , there are a limited number of possible sequences and so all possible combinations can be tried beforehand to find the favourable sequences. An interleaver algorithm can then be developed to quickly match a favourable sequence from a PAPR perspective with minimum computational overhead.

The findings in this paper can be used in many interesting cross-layer systematization problems to include PAPR considerations. For example, in [3], [40], [41], frequency diversity gains in terms of error rate performance were demonstrated. This could be coupled with selecting a scheme like LDS that has the phase bias for accompanying PAPR gains for high-rate users. Further, 5G and beyond communication systems are intended to support a wide variety of use-cases with users of very different requirements. This includes the level of PAPR tolerance among the users in the system. For instance, we saw that with the diversity scheme, some users are offered more SC separation than others, which impacts the PAPR statistics. Users with the least PAPR tolerance can be assigned the most favourable SC separation.

APPENDICES A

ZERO DB PAPR CONSTELLATION DESIGN

A zero dB constellation PAPR means zero dB PAPR for the transmission of one modulation symbol, i.e., $L = 1$. Such a constellation scheme requires each modulation symbol to be coded on only one of the d_v SCs. The N dimensional codewords already allocate $N - d_v$ null dimensions, but the zero dB PAPR constraint means that out of the remaining d_v dimensions, only one can be non-zero. Further, the magnitude of each of these symbol points should also be constant. For an M -point constellation, this translates to having $N_d = M/d_v$ points per dimension evenly spaced around a circle. To normalize the energy of the constellation, this needs to be

the unit circle. Therefore, we have an N_d -PSK constellation shape in the d_v dimensions. The M symbols are then assigned such that each symbol gets exactly one non-zero constellation point in any one dimension. However, which symbol is assigned to which constellation point is not important from a PAPR perspective. Algorithm 2 illustrates the construction of this constellation, that we call M -0PAPR because of the zero dB constellation PAPR property. The 4-point and 16-point version, namely 4-0PAPR and 16-0PAPR, are shown in Fig. 10a and 10b, respectively.

Algorithm 2: M -0PAPR SCMA Scheme

M : Number of points in constellation

d_v : Number of non-zero dimensions from \mathcal{S}

Step-1 Each RE is allocated M/d_v points evenly spaced around the unit circle;

Step-2 Each of the M points is labelled uniformly so that it is non-zero in only one of the dimensions;

Output: A d_v -dimensional, M -point constellation having 0 dB constellation PAPR since each symbol is non-zero in only one dimension

REFERENCES

- [1] Y. Chen, A. Bayesteh, Y. Wu, B. Ren, S. Kang, S. Sun, Q. Xiong, C. Qian, B. Yu, Z. Ding, S. Wang, S. Han, X. Hou, H. Lin, R. Visoz, and R. Razavi, "Toward the standardization of non-orthogonal multiple access for next generation wireless networks," *IEEE Commun. Mag.*, vol. 56, no. 3, pp. 19–27, Mar. 2018.
- [2] H. Nikopour and H. Baligh, "Sparse code multiple access," in *Proc. IEEE Annu. Int. Symp. Pers., Indoor, Mobile Radio Commun. (PIMRC)*, Sep. 2013, pp. 332–336.
- [3] M. Vameghestahbanati, I. Marsland, R. H. Gohary, and H. Yanikomeroglu, "Multidimensional constellations for uplink SCMA systems—A comparative study," *IEEE Commun. Surveys Tuts.*, vol. 21, no. 3, pp. 2169–2194, 3rd Quart., 2019.
- [4] L. Yang, X. Lin, X. Ma, and K. Song, "Clipping noise-aided message passing algorithm for SCMA-OFDM system," *IEEE Commun. Lett.*, vol. 22, no. 10, pp. 2156–2159, Oct. 2018.
- [5] L. Yang, X. Lin, X. Ma, and S. Li, "Iterative clipping noise elimination of clipped and filtered SCMA-OFDM system," *IEEE Access*, vol. 6, pp. 54427–54434, 2018.
- [6] Y. Rahmatallah and S. Mohan, "Peak-to-average power ratio reduction in OFDM systems: A survey and taxonomy," *IEEE Commun. Surveys Tuts.*, vol. 15, no. 4, pp. 1567–1592, 4th Quart., 2013.
- [7] M. Koziol. (Jul. 2019). *5G's Waveform Is a Battery Vampire*. [Online]. Available: <https://spectrum.ieee.org/telecom/wireless/5gs-waveform-is-a-battery-vampire>
- [8] S. C. Thompson, "Constant envelope OFDM phase modulation," Ph.D. dissertation, Dept. Elect. Eng., Univ. California, San Diego, San Diego, CA, USA, 2005.
- [9] H. Ochiai and H. Imai, "On the distribution of the peak-to-average power ratio in OFDM signals," *IEEE Trans. Commun.*, vol. 49, no. 2, pp. 282–289, Feb. 2001.
- [10] S. Hussain, "Peak to average power ratio analysis and reduction of cognitive radio signals," Ph.D. dissertation, Univ. Rennes, Rennes, France, 2009.
- [11] M. C. P. Paredes, D. M. Navarrete, and D. F. P. Placencia, "Analysis of quantization metrics for PAPR evaluation in OFDM systems," in *Proc. IEEE Latin-Amer. Conf. Commun. (LATINCOM)*, Nov. 2016, pp. 1–6.
- [12] J. Tellado-Mourelo, *Multicarrier Modulation With Low PAR: Applications to DSL and Wireless*. Norwell, MA, USA: Kluwer, 2002.
- [13] M. Taherzadeh, H. Nikopour, A. Bayesteh, and H. Baligh, "SCMA codebook design," in *Proc. IEEE Veh. Technol. Conf. (VTC)*, Sep. 2014, pp. 1–5.

- [14] J. Bao, Z. Ma, Z. Ding, G. K. Karagiannidis, and Z. Zhu, "On the design of multiuser codebooks for uplink SCMA systems," *IEEE Commun. Lett.*, vol. 20, no. 10, pp. 1920–1923, Oct. 2016.
- [15] M. Beke and R. Dinis, "Designing good multi-dimensional constellations," *IEEE Wireless Commun. Lett.*, vol. 1, no. 3, pp. 221–224, Jun. 2012.
- [16] T. Metkarunchit, "SCMA codebook design based on circular-QAM," in *Proc. Integr. Commun., Navigat. Surveill. Conf. (ICNS)*, Apr. 2017, pp. 3E1-1–3E1-8.
- [17] J. Bao, Z. Ma, M. Xiao, T. A. Tsiftsis, and Z. Zhu, "Bit-interleaved coded SCMA with iterative multiuser detection: Multidimensional constellations design," *IEEE Trans. Commun.*, vol. 66, no. 11, pp. 5292–5304, Nov. 2018.
- [18] K. Au, L. Zhang, H. Nikopour, E. Yi, A. Bayesteh, U. Vilaipornsawai, J. Ma, and P. Zhu, "Uplink contention based SCMA for 5G radio access," in *Proc. IEEE Globecom Workshops (GC Wkshps)*, Dec. 2014, pp. 900–905.
- [19] A. Bayesteh, H. Nikopour, M. Taherzadeh, H. Baligh, and J. Ma, "Low complexity techniques for SCMA detection," in *Proc. IEEE Globecom Workshops (GC Wkshps)*, Dec. 2015, pp. 1–6.
- [20] J. Bao, Z. Ma, M. A. Mahamadu, Z. Zhu, and D. Chen, "Spherical codes for SCMA codebook," in *Proc. IEEE Veh. Technol. Conf. (VTC Spring)*, May 2016, pp. 1–5.
- [21] H. Yan, H. Zhao, Z. Lv, and H. Yang, "A top-down SCMA codebook design scheme based on lattice theory," in *Proc. IEEE 27th Annu. Int. Symp. Pers., Indoor, Mobile Radio Commun. (PIMRC)*, Sep. 2016, pp. 1–5.
- [22] Z. Mheich, L. Wen, P. Xiao, and A. Maaref, "Design of SCMA codebooks based on golden angle modulation," *IEEE Trans. Veh. Technol.*, vol. 68, no. 2, pp. 1501–1509, Feb. 2019.
- [23] H. Nikopour, E. Yi, A. Bayesteh, K. Au, M. Hawryluck, H. Baligh, and J. Ma, "SCMA for downlink multiple access of 5G wireless networks," in *Proc. IEEE Global Commun. Conf. (GLOBECOM)*, Austin, TX, USA, Dec. 2014, pp. 3940–3945.
- [24] T. Jiang and Y. Wu, "An overview: Peak-to-average power ratio reduction techniques for OFDM signals," *IEEE Trans. Broadcast.*, vol. 54, no. 2, pp. 257–268, Jun. 2008.
- [25] D. W. Lim, S. J. Heo, and J. S. No, "An overview of peak-to-average power ratio reduction schemes for OFDM signals," *J. Commun. Netw.*, vol. 11, no. 3, pp. 229–239, Jun. 2009.
- [26] M. Ali, R. K. Rao, and V. Parsa, "PAPR reduction in OFDM systems using clipping based on symbol statistics," in *Proc. IEEE Can. Conf. Elect. Comput. Eng. (CCECE)*, Apr. 2017, pp. 1–5.
- [27] R. W. Bäuml, R. F. H. Fischer, and J. B. Huber, "Reducing the peak-to-average power ratio of multicarrier modulation by selected mapping," *Electron. Lett.*, vol. 32, no. 22, pp. 2056–2057, Oct. 1996.
- [28] A. D. S. Jayalath and C. Tellambura, "The use of interleaving to reduce the peak-to-average power ratio of an OFDM signal," in *Proc. IEEE Global Telecommun. Conf. (GLOBECOM)*, vol. 1, Nov. 2000, pp. 82–86.
- [29] B. S. Krongold and D. L. Jones, "PAR reduction in OFDM via active constellation extension," *IEEE Trans. Broadcast.*, vol. 49, no. 3, pp. 258–268, Sep. 2003.
- [30] A. Aggarwal and T. H. Meng, "Minimizing the peak-to-average power ratio of OFDM signals using convex optimization," *IEEE Trans. Signal Process.*, vol. 54, no. 8, pp. 3099–3110, Aug. 2006.
- [31] L. J. Cimini and N. R. Sollenberger, "Peak-to-average power ratio reduction of an OFDM signal using partial transmit sequences," *IEEE Commun. Lett.*, vol. 4, no. 3, pp. 86–88, Mar. 2000.
- [32] I. Baig, N. U. Hasan, M. Zghaibeh, I. U. Khan, and A. S. Saand, "A DST precoding based uplink NOMA scheme for PAPR reduction in 5G wireless network," in *Proc. Int. Conf. Modeling, Simulation, Appl. Optim. (ICMSAO)*, Apr. 2017, pp. 1–4.
- [33] C. Qian, Q. Xiong, B. Yu, and C. Sun, "Low complexity detection algorithm for low PAPR interleaving based NOMA schemes," in *Proc. IEEE Veh. Technol. Conf. (VTC-Fall)*, Sep. 2017, pp. 1–5.
- [34] I. Baig, "A precoding-based multicarrier non-orthogonal multiple access scheme for 5G cellular networks," *IEEE Access*, vol. 5, pp. 19233–19238, 2017.
- [35] I. Baig, U. Farooq, N. U. Hasan, M. Zghaibeh, U. M. Rana, M. Imran, and M. Ayaz, "On the PAPR reduction: A novel filtering based Hadamard transform precoded uplink MC-NOMA scheme for 5G cellular networks," in *Proc. Int. Conf. Comput. Appl. Inf. Secur. (ICCAIS)*, Apr. 2018, pp. 1–4.
- [36] M. Sharif, M. Gharavi-Alkhanisari, and B. H. Khalaj, "On the peak-to-average power of OFDM signals based on oversampling," *IEEE Trans. Commun.*, vol. 51, no. 1, pp. 72–78, Jan. 2003.
- [37] B. Wang, P. H. Ho, and C. H. Lin, "OFDM PAPR reduction by shifting null subcarriers among data subcarriers," *IEEE Commun. Lett.*, vol. 16, no. 9, pp. 1377–1379, Sep. 2012.
- [38] M. S. Hossain and T. Shimamura, "Low-complexity null subcarrier-assisted OFDM PAPR reduction with improved BER," *IEEE Commun. Lett.*, vol. 20, no. 11, pp. 2249–2252, Nov. 2016.
- [39] T. Wattanasuwakull and W. Benjapolakul, "PAPR reduction for OFDM transmission by using a method of tone reservation and tone injection," in *Proc. 5th Int. Conf. Inf. Commun. Signal Process.*, Dec. 2005, pp. 273–277.
- [40] R. Hoshyar, R. Razavi, and M. Al-Imari, "LDS-OFDM an efficient multiple access technique," in *Proc. IEEE Veh. Technol. Conf. (VTC-Spring)*, May 2010, pp. 1–5.
- [41] A. B. Sergienko and V. P. Klimentyev, "SCMA detection with channel estimation error and resource block diversity," in *Proc. Int. Siberian Conf. Control Commun. (SIBCON)*, May 2016, pp. 1–5.



ADITYA S. RAJASEKARAN received the B.Eng. (Hons.) and M.Eng. degrees in systems and computer engineering from Carleton University, Ottawa, ON, Canada, in 2014 and 2017, respectively, where he is currently pursuing the Ph.D. degree in systems and computer engineering. His research interests include wireless technology solutions aimed towards 5G and beyond cellular networks, including non-orthogonal multiple access solutions.

He is also with Ericsson Canada, where he has been a Software Developer, since 2014. He is currently involved in the physical layer development work for Ericsson's 5G New Radio (NR) solutions.



MONIROSHARIEH VAMEGHESTAHBANATI was born in Iran. She received the B.Sc. degree (Hons.) in electrical engineering from the Ajman University of Science and Technology, United Arab Emirates, in 2010, and the M.Sc. degree in electrical engineering from the American University of Sharjah, United Arab Emirates, in 2012. She is currently pursuing the Ph.D. degree with the Department of Systems and Computer Engineering, Carleton University, Ottawa, ON, Canada. Her

research interests include error control codes and non-orthogonal multiple access.

She has been a member of Huawei-Carleton Collaborative Research Project, since 2017. She was a recipient of numerous awards, including the Ontario Trillium Scholarship, from 2013 to 2017, and the Outstanding Teaching Assistant Award at Carleton University, in 2017 and 2018.



MOHAMMAD FARSI was born in Iran. He received the B.Sc. degree in electrical engineering from the University of Tehran, in 2016. He is currently pursuing the M.Sc. degree in electrical engineering with Tarbiat Modares University. His research interests include wireless communications, fiber optics, neural networks, and machine learning.



HALIM YANIKOMEROGLU (F'17) received the B.Sc. degree in electrical and electronics engineering from Middle East Technical University, Ankara, Turkey, in 1990, and the M.A.Sc. degree in electrical engineering (now ECE) and the Ph.D. degree in electrical and computer engineering from the University of Toronto, Canada, in 1992 and 1998, respectively.

From 1993 to 1994, he was with the Research and Development Group of Marconi Kominikasyon A.S., Ankara, Turkey. Since 1998, he has been with the Department of Systems and Computer Engineering, Carleton University, Ottawa, Canada, where he is currently a Full Professor. He has supervised 22 Ph.D. and 28 M.A.Sc. students (all completed with theses) several of his Ph.D. students received various medals. He has been one of the most frequent tutorial presenters in the leading international IEEE conferences (33 times). He has had extensive collaboration with the Canadian and international industry. From 2012 to 2016, he led one of the largest academic-industrial collaborative research projects on prestandards 5G wireless networks. His collaborations with industry have resulted in 34 granted patents. His research interests cover many aspects of wireless technologies. He is also a Fellow of the Engineering Institute of Canada (EIC) and the Canadian Academy of Engineering (CAE). He is also a Distinguished Speaker of the IEEE Communications Society and the IEEE Vehicular Technology Society on 5G/6G wireless technologies. He was a recipient of the IEEE Communications Society Wireless Communications Technical Committee Recognition Award, in 2018, the IEEE Ottawa Section Outstanding Service Award, in 2018, the IEEE Ottawa Section Outstanding Educator Award, in 2014, the Carleton University Faculty Graduate Mentoring Award, in 2010, the Carleton University Graduate Students Association Excellence Award in Graduate Teaching, in 2010, and

the Carleton University Research Achievement Award, in 2009 and 2018. He is also the Steering Committee Chair of IEEE's flagship Wireless Communications and Networking Conference (WCNC). He served as the General Chair VTC2017-Fall Toronto and VTC2010-Fall Ottawa, and a Technical Program Chair WCNC 2014 Istanbul, WCNC 2008 Las Vegas, and WCNC 2004 Atlanta of several major international IEEE conferences. He was the Chair of the IEEE Technical Committee on Personal Communications. He has served on the Editorial Boards of the IEEE TRANSACTIONS ON COMMUNICATIONS, IEEE TRANSACTIONS ON WIRELESS COMMUNICATIONS, and IEEE COMMUNICATIONS SURVEYS AND TUTORIALS. He has served as a Guest Editor in various IEEE journals special issues. He is also a registered Professional Engineer ON, Canada.



HAMID SAEEDI received the B.Sc. and M.Sc. degrees from the Sharif University of Technology, Tehran, Iran, in 1999 and 2001, respectively, and the Ph.D. degree from Carleton University, Ottawa, ON, Canada, in 2007, all in electrical engineering. From 2008 to 2009, he was a Postdoctoral Fellow with the Department of Electrical and Computer Engineering, University of Massachusetts, Amherst, MA, USA. In 2010, he joined the Department of Electrical and Computer Engineering, Tarbiat Modares University (TMU), Tehran, where he is currently an Associate Professor. His research interests include coding and information theory, and wireless communications. From 2014 to 2018, he was a member of the Editorial Board of the IEEE COMMUNICATIONS LETTERS. He is currently an Associate Editor of the IEEE TRANSACTIONS ON COMMUNICATIONS.

• • •