

Received August 14, 2019, accepted August 31, 2019, date of publication September 16, 2019, date of current version October 1, 2019.

Digital Object Identifier 10.1109/ACCESS.2019.2941749

Design and Test of 500-kV Lightning Protection Insulator

ZHENGLONG JIANG¹, WEI WU¹, BOWEN WANG¹, PENGKANG XIE¹, HUA LI²,
AND FUCHANG LIN²

¹State Key Laboratory of Disaster Prevention and Reduction for Power Grid Transmission and Distribution Equipment State Grid, Disaster Prevention and Reduction Center, State Grid Hunan Electric Power Company Ltd., Changsha 401205, China

²State Key Laboratory of Advanced Electromagnetic Engineering and Technology, School of Electrical and Electronic Engineering, Huazhong University of Science and Technology, Wuhan 430074, China

Corresponding author: Bowen Wang (bowen_wm@163.com)

This work was supported by the State Grid Corporation of China Science and Technology Program under Grant 5216A015001N and Grant 5216A01700UD.

ABSTRACT In this paper, based on insulation coordination and simulation, a lightning protection composite insulator is proposed, made up of an insulation part and an arrester part connected in series, whose length is close to that of the standard composite insulator, which met the window size requirements of the tower. The arrester part contains zinc oxide resistors and an internal core rod, which has good explosion-proof performance and tensile strength, in the meantime overcomes the problem that arresters cannot bear the tensile load of transmission lines. Electrical simulations and experiments have shown that the shielding failure current can be released through the proposed lightning protection insulator to the ground and the counterattack current can be prevented from entering the line. The dry-arc distances of the arrester part and the insulation part are 2.4 and 2.2 m respectively, and the grading ring distance is 1.8 m. The maximum AC withstanding voltage reaches 700 kV, and the switching overvoltage impulse withstanding voltage reaches 1200 kV. The proposed insulator can prevent lightning accidents from happening. Moreover, its length, tensile load, and installation mode are the same as existing line insulators, which has the advantages of low cost and ease of installation and maintenance.

INDEX TERMS Transmission line, insulator, arrester, lightning protection, design, test.

I. INTRODUCTION

With the fast development of power systems, more and more extra high voltage (EHV) transmission lines have been built across complex terrain where lightning is frequent. According to operating experience in China, lightning is the main reason for flashover of EHV transmission lines [1]. Electrical accidents caused by lightning impose a heavy burden of economic losses and maintenance work every year [2]–[5].

To reduce electrical accidents caused by lightning, transmission-line arresters and overhead grounding lines are being used. Air-gapped arresters can protect insulators from lightning flashover [6]–[10], at the same time, overhead grounding lines can protect conductors from shielding failure to a certain extent. In some countries like China [11], [12] and Japan, arcing horns are installed between the two ends of insulators, this method can prevent surface ablation of the

insulators caused by lightning flash. Installing an arcing horn arc-gap device will to a certain degree reduce the line insulation level, and increase the rate of lightning flash trips [13]. From the aspect of 500kV system insulation coordination, it is difficult to achieve an effective match of the distances between the arc horns and the insulators [14].

Two kinds of arresters are generally adopted: air-gapped arresters and gapless arresters. Gapless arresters are usually installed on the first fundamental tower near the substation or directly installed inside a substation. Gapless arresters are used to protect substation electrical equipment from damages due to incoming lightning waves. The gapless arresters must withstand the operating voltage. Once they are damaged, the transmission line must be shut down. Therefore, it needs to be tested before the thunderstorm season every year and the maintenance work will be heavy. During operation of air-gapped arresters, no voltage is applied on the arrester parts, making the arrester easier to maintain. However, the electrical properties of the air gap are easily affected by the climatic

The associate editor coordinating the review of this manuscript and approving it for publication was Andrei Muller.

environment. Moreover, existing arresters cannot suspend the wire. The arresters are usually 25% longer than the insulators; when they are installed in parallel with the insulators, the structure of the tower cross arm must be changed, leading to more installation difficulties and higher installation cost.

In view of the above discussion, based on insulation coordination analysis and simulation calculation, this paper proposes a new type of composite insulator with lightning protection functions. This lightning protection insulator can replace an insulator and an arrester without changing the installation type and tower structure, and it is also easy to install and maintain in practice.

II. STRUCTURE OF A NEW TYPE OF COMPOSITE INSULATOR

The function of the insulator is to suspend the wire and withstand power frequency and voltage, thus ensuring normal transmission-line operation. The proposed lightning protection insulator is made up of an insulation part and an arrester section, connected in series. As shown in Fig. 1, the metal connection fitting includes a ball socket and a bulb; grading rings are installed on both ends of the insulation part.

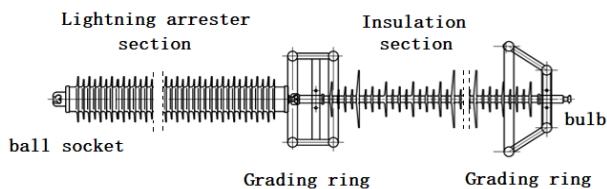

FIGURE 1. Structural diagram of lightning protection composite insulator.

When the device is struck by lightning, the air gap between the grading rings of the insulation part breaks down, and the lightning current flows into the ground through the arrester part. This prevents a short circuit from occurring between conductor and ground and thus avoids a lightning trip on the line [15]. The ring zinc oxide (ZnO) resistors of high gradient are used in the arrester part and suited into a glass-fiber core rod, and are put into an insulating cylinder with explosion-proof structure for mechanical performance improvement. The explosion-proof tanks are evenly distributed on the wall of insulating cylinder. Ring zinc oxide (ZnO) resistors are pressed by springs and are linked to ball fittings, forming the arrester part of the proposed insulator, as shown in Fig. 2.

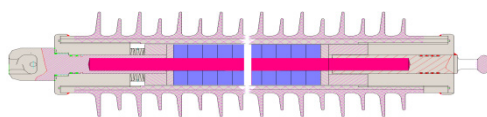

FIGURE 2. Structural diagram of lightning arrester.

Large, medium, and small sheds are used, and a reasonable design of the grading rings and the umbrella skirt structure can significantly improve insulator electric field distribution. Under rain and icing conditions, it can effectively delay or

even eliminate the ice bridge phenomenon, improving the ability to resist icing flashover [16]–[20].

III. PARAMETER DESIGN OF THE INSULATOR SECTION

A. POWER FREQUENCY OVER-VOLTAGE

During operations, the line voltage is mainly applied to the insulation section [21]. When the maximum internal over-voltage occurs, the insulation part should not break down. Under the action of working voltage and power frequency over-voltage, the outside insulation should not break down. The power frequency over-voltage level of the 500-kV system should not exceed 1.4 power units [22]. The maximum operating line voltage of the 500-kV system is 550 kV, and therefore the insulation segment should be able to withstand the maximum power frequency over-voltage of 445 kV.

Aleksandrov et al. [23], [24] obtained the critical power frequency flashover voltages of insulators and long air gaps. IEC60071-2 published the calculation formula for air intermittent distance or insulator dry-arc distance L (m) and the Alternating current (AC) critical discharge voltage in 1996 [25]. The results are consistent. The simplified calculation formula is shown as Eq. (1):

$$U_c = 750 \times \ln(1 + 0.55L^{1.2}), \quad (1)$$

where U_c is the RMS value of the critical AC flashover voltage and L is the length of the air gap. When L is 1.38 m, U_c equals 445 kV, which agrees with Knudsen’s research [26].

The insulation dry-arc distance of lightning protection composite insulator is 2.2 m, a grading ring diameter of 450 mm, a tube diameter of 40 mm, and a grading-ring spacing distance of 1.8 m, the power frequency insulation breakdown flashover voltage is about 680 kV, which is 1.53 times the peak working frequency over-voltage applied to the lightning protection insulator. Even under wet conditions, external insulation flashover accidents will not occur under power frequency working conditions, which is about 0.87 times the flashover voltage under dry conditions [27].

B. SWITCHING OVER-VOLTAGE

For a 500-kV power system, the switching overvoltage is not greater than 2.0 power units [22]. Hence, the maximum switching overvoltage that the composite insulator can withstand is 898 kV, according to the switching impulse over-voltage test of a composite insulator performed by КОРЯБИИ in Russia [28]. The positive-polarity switching overvoltage flashover voltage is lower than its negative-polarity counterpart, and the formulas for dry and wet positive-polarity switching overvoltage impulse flashover voltage is proposed, as below:

$$U_{sd50\%+} = 179L_d + 1024, \quad (2)$$

$$U_{sw50\%+} = 644L_d^{0.657}. \quad (3)$$

where $U_{sd50\%+}$ and $U_{sw50\%+}$ are the dry and wet 50% positive-operating switching impulse flashover voltage respectively. L_d is the dry-arc distance of insulator, m.

According to Eq. (2) and (3), for a composite insulator with a dry-arc distance of 1.8 m, the positive-operating pulse dry and wet 50% flashover voltages are 1346.2 kV and 947.5 kV, respectively. Hence, the lightning protection insulator can withstand the maximum operating pulse over-voltage of the power system.

IV. PARAMETER DESIGN OF THE ARRESTER PART AND LIGHTNING PROTECTION SIMULATION

A. EXTERNAL INSULATION DESIGN OF THE ARRESTER PART

When the insulation part is broken down by lightning, the operating voltage and the potential power frequency over-voltage are applied to the arrester section. Therefore, the arrester should be able to withstand both working voltage and power frequency over-voltage.

Using the working and power frequency over-voltages of the insulator part as a reference, the dry-arc distance of the arrester part was chosen as 2.2 m.

The external insulation of the arrester part must also withstand lightning over-voltage. After the air gap between the grading rings has been broken down by lightning, the lightning over-voltage is applied to the arrester part, but because of the nonlinear V-I characteristics, the over-voltage applied to the arrester part is restricted. For external insulation of the arrester part, according to the test curve of 50% lightning flashover voltage of the rod-plane air gap given by Pigini in 1989 [29], its 50% positive/negative lightning flashover voltages were 1200 kV and 1600 kV respectively. In this study, the inner diameter/ outer diameter/ thickness of the annular ZnO resistor were 26 mm/ 85 mm/ 22 mm respectively. Under 40 kA lightning current (8/20 μs), the residual voltage of the annular ZnO resistor was only 11.1 kV. The number of the annular ZnO resistors in the arrester section was selected appropriately, and the residual voltage of the arrester was no more than 1200kV. Therefore, the external insulation flashover of arrester shouldn't occur.

When the arrester is designed, the outer insulating dry arc distance is longer than 2.4m in order to improve the safety factor.

B. ZnO RESISTORS

A ring zinc oxide resistor was developed, its gradient was 272V/mm. The outer diameter / inner diameter /thickness of the ring zinc oxide resistor were 85mm/26mm/22mm respectively; its test value of 2ms square wave current was 1650A; and its residual voltage was between 11.0kV ~11.1 kV under 40 kA lightning current (8/20 μs).

The V-I characteristics of a single ZnO resistor can be obtained by a high-current test, as shown in table 1.

The reference voltage of the arrester should not be lower than the maximum power frequency over-voltage of 445 kV; the reference voltage of a ring zinc oxide resistor is 5.99kV; and the number of resistors should not less than 75 tablets. If the outer insulation flashover of the arrester should not occur

TABLE 1. The V-I characteristics of a single ZnO resistor.

Current (A)	Voltage (kV)	Current (A)	Voltage (kV)
0.001	5.99	2280	10.10
0.06	7.05	10000	10.50
165	9.31	20000	10.73
707	9.73	40000	11.07

under 40kA lightning current, its residual voltage should be less than 1200kV, then the number of resistors must be less than 108 tablets. The number of resistors inside the arrester is between 75 and 108 tablets. The simulation mode is built to analyze the lightning protection characteristic of the lightning protection composite insulator.

The type of glass linear tower shown in Fig. 3 is commonly seen on 500kV transmission lines. In the lightning simulation, the tower was built according to the Hara multiple-wave impedance model. The simulation model under lightning conditions is shown in Fig. 4. The average span is 400 m. The ground line type is GJ-80. The conductor type is 4×LGJ-400/35. The split conductor spacing is 450 mm. The grounding resistance is 7Ω.

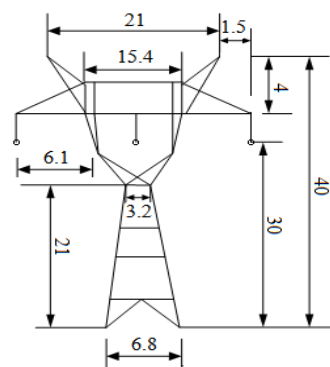

FIGURE 3. The tower model.

In the lightning protection simulation, the formula in the electrical geometric model and the IEEE standard were used, as shown in Eq. (4):

$$r_s = 10I^{0.65} \tag{4}$$

where r_s is the striking distance. I is the current, kA. The 1.2/50 μs dual exponential equation recommended by the International Electrotechnical Commission (IEC) was adopted as the lightning impact standard waveform.

In Fig.4, the wave impedance of each part of the tower is calculated, and the results are shown in table 2. The influence of the tower auxiliary materials are expressed in Z5 and Z7. And the switch k was used to represent a lightning strike on conductors or grounding lines. The lightning protection insulator was modeled as a controlled switch and an arrester connected in series, as shown in Fig. 5, which is tested

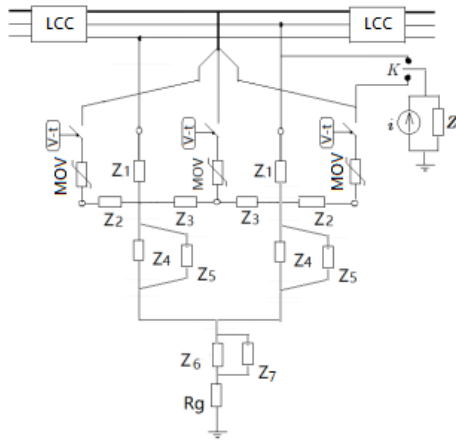

FIGURE 4. Simulation model of lightning striking a 500-kV transmission line.

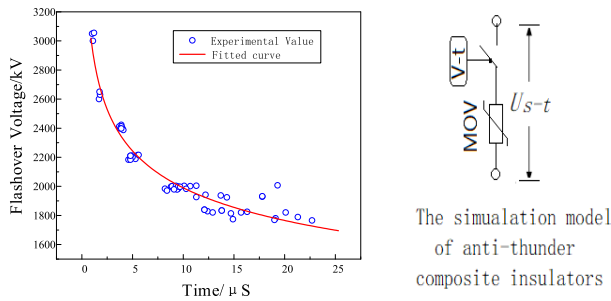

FIGURE 5. Simulation model of anti-thunder composite insulators and their volt-second characteristics.

TABLE 2. Wave impedance of the tower.

Parameters	Wave impedance/ Ω	Length/m
Z1	305	4.0
Z2	298	6.1
Z3	298	5.9
Z4	141	15
Z5	1267	15
Z6	72	21
Z7	646	21

under negative lightning impulse. The switch action was controlled by the volt-second of the lightning protection insulator obtained by negative lightning characteristic impulse tests.

Through curve fitting, the breakdown characteristics of the grading-ring gap of the lightning protection insulator under the action of lightning strike were determined by the following equation:

$$U_{s-t} = 1766 - 1183t^{0.835} \quad (5)$$

where U_{s-t} (kV) is the voltage of the lightning protection insulator when the air gap is broken down by lightning and t (us) is the time from the beginning of lightning to flashover.

The 500-kV transmission line crosses many kinds of topography, such as plains and mountainous areas. It was considered that the tower was located on a sloping hillside

not greater than 30° . According to the electrical geometry method, the simulation results are shown in table 3.

TABLE 3. Simulation results when the transmission line is struck by lightning.

Lightning type	Shielding failure	Counterattack
Lightning current amplitude I/kA	-34.7	-300
Lightning current probability P/%	40.33%	0.04%
Current flowing through arresters/ kA	-24.1	14.0
Maximum residual voltage of the arrester /kV	1032	1013

The probabilities of lightning current amplitude were calculated according to Chinese standard [22] in table 3. The maximum lightning current of back striking was considered to be 300kA. And the number of resistors in the arrester section was 95 tablets. When the maximum shielding failure current was -34.7kA, the amplitude of lightning current released through the arrester was 24.1kA. But the lightning current flowing into the wire through the arrester was no more than 5% of the counterattack current; And the maximum residual voltage of the arrester was Only 1032 kV, no more than the insulation flashover voltage of arrester under lightning shock. Lightning on the conductors and towers (or ground) cannot cause arrester insulated flashover.

V. MAIN DESIGN PARAMETERS AND TESTING OF 500KV LIGHTNING PROTECTION INSULATORS

In this paper, main design parameters and critical testing of 500kV lightning protection insulator are introduced. Critical test items include explosion-proof test, frequency voltage tolerance, operation impact tolerance test, lightning impact flashover, and etc. These test data are very important for the normal operation of 500kV Lightning Protection Insulator.

A. MAIN DESIGN PARAMETERS

Main design parameters that have a signification effect on the normal operation of 500kV Lightning Protection Insulator include the dry-arc distances of the lightning arrester unit, the insulator unit, grading ring size, spacing distance, and etc. The two ends of the core rod and the metal tool were made by means of compression, and the compression length is 55 mm. Table 4 shows the main structural parameters.

B. TESTING OF KEY PARAMETERS

1) TENSILE AND SHORT CIRCUIT CURRENT TEST

The test device for short circuit current test consists of a short-circuit generator and booster short-circuit transformer. Test current was 63kA. Test current maintenance was 2s. Some of umbrella skirts were burned down during short circuit current test, and the internal air pressure was released through the damaged place. There was no internal debris splashing out. Tensile load test after short circuit current test were carried

TABLE 4. Structural parameters of lightning protection composite insulator.

Item	Parameters
Overall length	≤4950mm
Length/dry-arc distance of lightning arrester unit	2630mm/2400mm
Length/dry-arc distance of insulator unit	2320mm/2200mm
Umbrella skirt diameter	350mm/250mm/200mm
Umbrella spacing	45mm
Grading ring diameter/ tube diameter / spacing distance	450mm/40mm/1.8m
Mandrel diameter	24mm
Inner diameter/ outer diameter/ thickness of the annular ZnO	85mm/26mm/22mm
Number of resistors	95 tablets
Crimping length	55mm

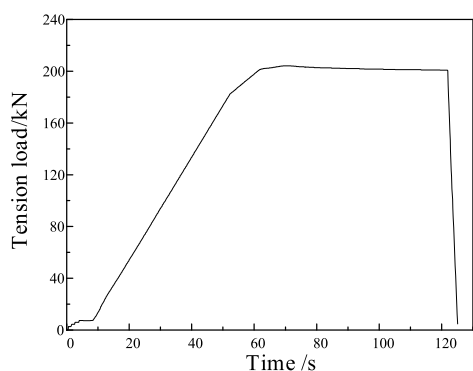

FIGURE 6. Tensile load test curve.

out. The lightning protection insulators could withstand the 21000kg/60s tensile load test, same as before short circuit current test, as shown in Fig. 6, while the failure load value reached 25000 kg.

2) WITHSTANDING TESTS OF POWER FREQUENCY AND OPERATING IMPACT

The withstanding voltages for power frequency and operating impulse voltage were tested to verify whether the lightning protection insulator could meet the requirements of transmission-line operation.

During wet and dry withstanding tests of the insulator unit, the withstanding voltage was 510 kV with 5 min withstanding time. During the withstanding tests, no discharge or visible corona was observed. The test voltage continued being raised above 20kV, and a visible corona discharge appeared. The conductivity of rain was 97 Ω·m.

When the arrester part and the insulation unit were connected with a 1.8-m equalizing ring spacing, the wet and

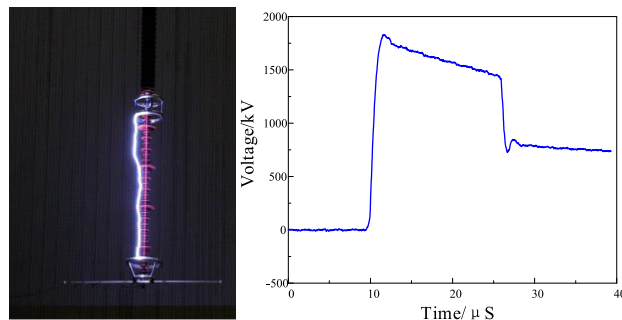

FIGURE 7. Discharge phenomenon of lightning protection insulator under positive lightning shock.

dry withstanding voltages were as high as 700 kV, no abnormal discharge or visible corona was observed. It is apparent that compared with the insulation section alone, the whole lightning protection insulator’s power frequency withstanding voltage and breakdown voltage have been significantly increased owing to the arrester part for withstanding partial voltage.

The up-and-down method was used in the flashover experiment, with a standard switching impulse waveform (250/2500 μs). The 50% positive/negative flashover voltages of the insulation part were 970 kV and 1150 kV, and the operating impact withstanding voltages of the whole insulator were higher than 1200 kV.

3) LIGHTNING FLASHOVER TESTS

Lightning flashover tests were also carried out. With a standard lightning waveform (1.2/50 μs), the 50% positive/negative lightning flashover voltages of the insulation part were 1120 kV and 1190 kV respectively, and the 50% positive/negative lightning flashover voltages of the whole insulator were 1720 kV and 2000 kV respectively. Figure 7 shows the flashover phenomenon, revealing that flashover always occurred between the air gaps of the grading rings and that the insulator sheds were not damaged by the lightning current.

4) THE PERFORMANCE UNDER POLLUTION CONDITIONS

The suspension of sodium chloride and kieselguhr which respectively simulate the electric and inert materials is used to pollute the surface of the specimens. The SDD value is 0.25 mg/cm². The ratio of SDD to NSDD is 1:6 for the tests. The test sample is suspended vertically at the top of the artificial climate chamber. The sample is wetted for 15 to 20 minutes and the test is started immediately when the surface of the insulator is sufficiently wet. The experimental results indicate that the insulator withstand 510kV, 5min, which is meet the normal operation requirements.

VI. CONCLUSION

This paper proposes a new type of lightning protection insulator. Dozens of this lightning protection insulator have been installed on the 500kV chang-min line to verify the operating

effect. From simulation analysis and experimental results, the following conclusions can be drawn:

(1) The lightning protection insulator is formed by an insulator and an arrester connected in series, where the dry-arc distances of the arrester part and the insulation part are 2.4 and 2.2 m respectively, and the grading ring distance is 1.8 m. The maximum AC withstanding voltage reaches 700 kV, and the switching overvoltage impulse withstanding voltage reaches 1200 kV. It can withstand the maximum internal over-voltage of the power system, and meets power-grid operating requirements

(2) When a transmission line is struck by lightning, the lightning protection insulator can release shielding failure current to the earth, and prevent counterattack current from entering the line. It can effectively prevent lightning accidents from happening.

(3) The length of the proposed insulator is close to that of the standard composite insulator, which met the window size requirements of the tower. It has excellent explosion-proof performance and tensile strength, which can replace the normal insulator to hang transmission wires.

REFERENCES

- [1] Z. Zhi-Jin, S. Wen-Xia, J. Xing-Liang, S. Cai-Xin, and S. Li-Chun, "Study on the lightning protection performance of shielding failure for UHV&EHV transmission lines," *Proc. CSEE*, vol. 25, no. 10, pp. 1–6, 2005.
- [2] J. Takami and S. Okabe, "Observational results of lightning current on transmission towers," *IEEE Trans. Power Del.*, vol. 22, no. 1, pp. 547–556, Jan. 2007.
- [3] S. Okabe, T. Tsuboi, and J. Takami, "Analysis of aspects of lightning strokes to large-sized transmission lines," *IEEE Trans. Dielectr. Electr. Insul.*, vol. 18, no. 1, pp. 182–191, Feb. 2011.
- [4] J.-C. Hao, J.-Y. Zhang, and Y. Tian, "Faults analysis of circuit-breaker caused by continuous lightning strike on lines," (in Chinese), *High Voltage App.*, vol. 46, no. 10, pp. 105–108, Oct. 2010.
- [5] Z. Fang, B. Wang, J. Lu, and Z. Jiang, "Study on impulse breakdown characteristics of internal-gap lightning protection device applied to 35 kV distribution line," *Energies*, vol. 11, no. 7, p. 1758, Jul. 2018.
- [6] M.-H. Wang, S. Yan, S.-C. Tan, and S. Y. Hui, "Hybrid-DC electric springs for DC voltage regulation and harmonic cancellation in DC microgrids," *IEEE Trans. Power Electron.*, vol. 33, no. 2, pp. 1167–1177, Feb. 2018.
- [7] K. Munukutla, V. Vittal, G. T. Heydt, D. Chipman, and B. Keel, "A practical evaluation of surge arrester placement for transmission line lightning protection," *IEEE Trans. Power Del.*, vol. 25, no. 3, pp. 1742–1748, Jul. 2010.
- [8] J. Lu, B. Wang, Z. Fang, Z. Jiang, J. Hu, and W. Wu, "Study on the flashover performance of an anti-thunder composite insulator under ice accretion conditions for a 10 kV distribution line," *IEEE Trans. Electr. Electron. Eng.*, vol. 13, no. 12, pp. 1738–1746, Dec. 2018.
- [9] S. Gu, S. Wan, J. Wang, J. Chen, and T. Li, "Development and application of ± 500 kV DC transmission line arrester in china power grid," *IEEE Trans. Power Del.*, vol. 33, no. 1, pp. 209–217, Feb. 2018.
- [10] M.-H. Wang, K.-T. Mok, S.-C. Tan, and S. Y. R. Hui, "Multifunctional DC electric springs for improving voltage quality of DC grids," *IEEE Trans. Smart Grid*, vol. 9, no. 3, pp. 2248–2258, May 2018.
- [11] X.-Y. Chen, C.-G. Yin, D. Ge, C.-X. Zhang, X.-L. Wang, Z.-M. He, T. Yang, and W.-R. Wang, "Application investigation on parallel gap lightning protection device of composite insulators for 110kV transmission Line," (in Chinese), *High Voltage App.*, vol. 48, no. 2, pp. 60–65, 2012.
- [12] S. Y. Liang, Z. G. Li, and Z. Q. Li, "Calculation of electric field for 220 kV insulator with parallel gap," (in Chinese), *North China Electric Power*, vol. 10, no. 14, pp. 48–51, 2013.
- [13] S. Gu, W. Chen, J. He, R. Zeng, and G. Xu, "Movement simulation of three-phase short circuit arcs on distribution lines based on the coupling of magnetic field and motion," *IEEE Trans. Plasma Sci.*, vol. 36, no. 2, pp. 524–529, Apr. 2008.
- [14] M. Pu, "Development of a new type line MOA based on reviewing prevalent ones," (in Chinese), *Insulators Surge Arresters*, Vol. 4, pp. 21–24, Apr. 2004.
- [15] K. Ishida, K. Dokai, T. Isozaki, T. Irie, T. Nakayama, H. Fujita, K. Arakawa, and Y. Aihara, "Development of a 500 kV transmission line arrester and its characteristics," *IEEE Trans. Power Del.*, vol. 7, no. 3, pp. 1265–1274, Jul. 1992.
- [16] T. Xu, J. Nan, and X. Wan, "Research on icing flashover characteristic of different shed type composite insulators," in *Proc. Int. Conf. Inf. Sci., Electron. Elect. Eng.*, Sapporo, Japan, Apr. 2014, pp. 191–194.
- [17] S. Wang, L. Shu, X. Jiang, Q. Hu, and W. Yuan, "Influence of grading ring installation position on ice accretion and flashover characteristics of 220 kV composite insulators," (in Chinese), *Power Syst. Technol.*, vol. 37, no. 6, pp. 1619–1624, 2013.
- [18] Q. Hu, S. Wang, L. Shu, X. Jiang, G. Qiu, and H. Li, "Influence of shed configuration on icing characteristics and flashover performance of 220 kV composite insulators," *IEEE Trans. Dielectr. Electr. Insul.*, vol. 23, no. 1, pp. 319–330, Feb. 2016.
- [19] F. Yin, X. Jiang, M. Farzaneh, and J. Hu, "Electrical performance of 330-kV composite insulators with different shed configurations under icing conditions," *IEEE Trans. Dielectr. Electr. Insul.*, vol. 22, no. 6, pp. 3395–3404, Dec. 2015.
- [20] L. Shu, S. Wang, X. Jiang, Q. Hu, X. Yang, S. Yan, and J. Chen, "Effect of grading ring on ice characteristics and flashover performance of 220 kV composite insulators with different shed configurations," *IEEE Trans. Dielectr. Electr. Insul.*, vol. 22, no. 2, pp. 951–960, Apr. 2015.
- [21] Z. Jiang, W. Wu, X. Yin, B. Wang, Y. Yao, and P. Xie, "Optimization design and lightning & icing protection test of 500 kV anti-icing flash insulator with lightning protection function," (in Chinese), *High Voltage Eng.*, vol. 43, no. 12, pp. 3843–3849, Dec. 2017.
- [22] *Overvoltage Protection and Insulation Coordination for AC Electrical Installations*, Chinese Standard DL/T 620-1997.
- [23] G. N. V. Aleksandrov, V. Y. Kizveter, V. M. Rudakova, and A. N. Tushnov, "The AC flashover voltages of long air gaps and strings of insulators," *Elektrichest*, vol. 5, pp. 27–32, 1962.
- [24] G. N. V. Aleksandrov, I. Ivanov, and V. P. Radkov, "Electrical strength of air gaps between EHV line conductors and earth during surges," *Elektrichest*, vol. 4, pp. 20–24, 1965.
- [25] *Insulation Co-ordination Part 2: Application Guide*, document IEC60071-2:1996.
- [26] N. Knudsen and F. Iliceto, "Flashover tests on large air gaps with DC voltage and with switching surges superimposed on DC voltage," *IEEE Trans. Power App. Syst.*, vol. PAS-89, no. 5, pp. 781–788, May 1970.
- [27] *Guidelines for the Evaluation of the Dielectric Strength of External Insulation*, document CIGRE Working Group 33.07.1992, Tech. Brochure, CIGRE, Paris, France, vol. 72.
- [28] A. R. Koryavin and O. V. Volkova, "Impulse electric strength of polymer line insulators in dry and rain conditions," *Elect. Eng.*, vol. 3, pp. 13–19, 2001.
- [29] A. Pignini, G. Rizzi, E. Garbagnati, A. Porrino, G. Baldo, and G. Pesavento, "Performance of large air gaps under lightning overvoltages: Experimental study and analysis of accuracy predetermination methods," *IEEE Trans. Power Del.*, vol. 4, no. 2, pp. 1379–1392, Apr. 1989.



ZHENGLONG JIANG was born in Hunan, China, in 1968. He received the bachelor's and master's degrees in high-voltage engineering from the Huazhong University of Science and Technology (HUST). He is currently with the Disaster Prevention and Reduction Center, State Grid Hunan Electric Power Company Ltd.



WEI WU was born in Hunan, China, in 1987. He received the bachelor's and master's degrees in high-voltage engineering from Xi'an Jiaotong University. He is currently with the State Key Laboratory of Disaster Prevention and Reduction for Power Grid Transmission and Distribution Equipment.



BOWEN WANG was born in Hunan, China, in 1989. He received the bachelor's and master's degrees in high-voltage engineering from the Huazhong University of Science and Technology (HUST). He is currently with the State Key Laboratory of Disaster Prevention and Reduction for Power Grid Transmission and Distribution Equipment.

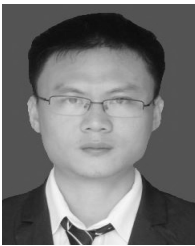

PENGGANG XIE was born in Hunan, China, in 1988. He received the bachelor's and master's degrees from the Huazhong University of Science and Technology (HUST), and the Ph.D. degree from Zhejiang University. He is currently with the State Key Laboratory of Disaster Prevention and Reduction for Power Grid Transmission and Distribution Equipment.



HUA LI received the B.E. and Ph.D. degrees from the Huazhong University of Science and Technology (HUST), Wuhan, China, in 2004 and 2007, respectively, where she is currently a Professor with the State Key Laboratory of Advanced Electromagnetic Engineering and Technology, College of Electrical and Electronic Engineering.



FUCHANG LIN was born in Zhejiang, China, in February 14, 1969. He received the Ph.D. degree in electrical and electronic engineering from the Huazhong University of Science and Technology (HUST), in 1996, where he is currently a Professor with the College of Electrical and Electronic Engineering. His research interests include pulsed power technology and high-voltage engineering.

...