

Received June 21, 2019, accepted July 19, 2019, date of publication July 29, 2019, date of current version August 13, 2019.

Digital Object Identifier 10.1109/ACCESS.2019.2931547

A Hybrid ANFIS-ABC Based MPPT Controller for PV System With Anti-Islanding Grid Protection: Experimental Realization

SANJEEVIKUMAR PADMANABAN¹, (Senior Member, IEEE),
NEERAJ PRIYADARSHI², (Member, IEEE),
MAHAJAN SAGAR BHASKAR³, (Member, IEEE),
JENS BO HOLM-NIELSEN¹,
VIGNA K. RAMACHANDARAMURTHY⁴, (Senior Member, IEEE),
AND EKLAS HOSSAIN⁵, (Senior Member, IEEE)

¹Center for Bioenergy & Green Engineering, Department of Energy Technology, Aalborg University, 6700 Esbjerg, Denmark

²Department of Electrical Engineering, Birsa Institute of Technology (Trust), Ranchi 835217, India

³Center for Bioenergy and Green Engineering, Department of Energy Technology, Aalborg University, 6700 Esbjerg, Denmark

⁴Institute of Power Engineering, Department of Electrical Power Engineering, Universiti Tenaga Nasional, Kajang 43000, Malaysia

⁵Department of Electrical Engineering and Renewable Energy, Oregon Institute of Technology, Klamath Falls, OR 97601, USA

Corresponding author: Sanjeevikumar Padmanaban (san@et.aau.dk)

This work was supported by the Oregon Renewable Energy Center (OREC), Department of Electrical Engineering and Renewable Energy, Oregon Tech, Klamath Falls, OR, USA.

ABSTRACT This paper introduces a novel control system with maximum power point tracker (MPPT) for the photovoltaic system with grid integration. Hybrid adaptive neuro-fuzzy inference system (ANFIS) and artificial bee colony (ABC) algorithm employed to optimize the membership function. Hence, for minimizing the root mean square error (RMSE), this controls the SEPIC-based MPPT algorithm to achieve rapid PV power tracking. The system performance is improved by fuzzy logic control (FLC), which generates the switching signal to the power switches of the inverter. A dSPACE (DS1104) control board employed for experimental validation of MPPT and inverter control strategies. The novelty of the proposed hybrid MPPT controller is the optimal tuning of ANFIS membership function with the ABC algorithm and been neither discussed before for PV power applications. The experimental responses completely validate the reliability of the PV grid integration with anti-islanding protection. The recentness of this research work is PV MPPT functioning using the hybrid ANFIS-ABC-based algorithm, been not described practically by any researchers in the past works.

INDEX TERMS ANFIS-ABC, dSPACE, fuzzy logic controller, MPPT, photovoltaic, SEPIC.

NOMENCLATURE

I_{ph} Photon current
 I_0 Current at reverse saturation
 q Charge on electron
 V_0 Output cell voltage
 K Boltzmann's constant
 T_c Cell operating temperature
 A Diode ideality factor
 R_s Series resistor of cell
 R_{SH} Shunt resistor of cell

I_{o1} Reverse saturation current at temperature t_r
 i_L, i_{L1} Inductor currents
 I_{D1}, I_{D2} Diode currents
 V_S Supply voltage
 R_L Load
 V_C Capacitor Voltage
 $\mu(W_i)$ Combined value of membership
 $F(R_i)$ Fitness function
 $f(R_i)$ Objective function
 V_{Qj} New food source position
 X_{ij} Food source current position
 J Random integer lies between 1 and p
 Q Random selection parameter 1,2,3...p

The associate editor coordinating the review of this manuscript and approving it for publication was Bora Onat.

- R_{ij} Random value between -1 and 1
 I Total input
 S Set of ANFIS-ABC rules

I. INTRODUCTION

DUE to atmospheric issues, inaccessibility of fossil fuels and energy crisis, renewable energy technology has received great attention of the investors and researchers [1]–[3]. Nowadays, among renewable energy sources, PV system gaining popularity, because it is environment-friendly, clean, produces no noise and requires less maintenance [4], [5]. However, the major obstacles of PV panels are low energy conversion efficiency due to non-linear PV array's I-V behavior, which is dependent on variable weather conditions [6]–[8]. In order to optimize the tracked PV efficiency, a Maximum Power Point Tracking (MPPT) system is required [9]–[13].

In recent years, numerous MPPT methods are discussed. For highly changing weather conditions, the Perturb and Observe (P&O) and incremental conductance methods of MPPT are not suitable [14], [15]. The artificial intelligence-based Fuzzy Logic Controller (FLC) and Artificial Neural Network (ANN) MPPT methods are suitable for uncertain weather conditions [16]. Because of the requirement of large training data, the ANN method fails to track accurate optimal power under adverse operating conditions. On the other hand, the FLC based MPPT transforms linguistic and heuristic variables to numerical parameters by application of proper membership functions as well as fuzzy rules. Nevertheless, membership functions and fuzzy inference rules depend on prior system knowledge. The FLC based MPPT controllers based on inference rule base, which can evaluate by trial and error process. Therefore, the design of FLC controllers has limitations of time-consuming adjustments of membership parameters. Moreover, the ANN consists of limitations such as lack of layers and cells defined rules with large training data requirement. ANFIS comprises the advantages of complementary algorithms of ANN and FLC; so that the fuzzy controller accuracy improved with minimized development period. It tracks maximum power from the PV panel and gives high accuracy and low oscillation around maximum power point (MPP) compared to all intelligent methods of MPPT discussed in the literature.

Several DC-DC converters for MPPT discussed to optimize the effectiveness of PV panel [17], [18]. In this work, the SEPIC buck-boost converter, employed as it has high power tracking capability and low input current ripple compared to other DC-DC converters. Two modes in which PV system is operated viz. grid connected and standalone. In grid-connected mode, the maximum extracted power from the PV system supplied to the electric grid. The PV grid integration is a difficult challenge to the engineers. Several conventional controllers e.g. Proportional Integral (PI), Proportional Integral Derivative (PID), Quasi Proportional Resonance (QPR), Proportional Resonant Integral (PRI) etc. have been discussed by designers to control the PV inverter [19].

Nevertheless, because of complex filter design, discrete frequency of utility grid and lack of adaptive intelligence, the classical controllers are unable to reduce total Harmonic Distortion (THD) and frequency stability respectively.

There are many inverter current control strategies have been discussed such as Predictive controller, Hysteresis current controller, Sine Pulse Width Modulation (SPWM), Space Vector Pulse Width Modulation (SVPWM) [20]–[23] etc. The major disadvantage of the predictive current controller has complex control strategy due to slow dynamic response as the response of the system affected by a variation of load. Due to the fixed hysteresis band, the switching frequency of the hysteresis controller becomes variable. As SPWM provides 0.785 modulation index and more than this, it generates high voltage ripple. However, the SVPWM provides 0.907 modulation index with improved Total Harmonic Distortion (THD). Nevertheless, Phase Locked Loop (PLL) makes a slow transient response of the system performance as far as SVPWM technique is concerned. In this research work, FLC based inverter control is implemented to overcome the disadvantages of uncertainty under adverse environmental conditions. This control strategy provides better dynamic response compared to other inverter control strategies discussed in the literature. However, updation and training of ANFIS membership function is the major concern with swarm intelligence techniques. Several swarm optimization and evolutionary algorithms used to optimize the ANFIS membership function. In [24], Genetic Algorithm-ANFIS algorithm has discussed for wind forecasting and weather prediction. This method provides optimal tuning to the membership function's parameters. It has merits viz. simple implementation, independent ANFIS structure, and fast computational speed. Nevertheless, the major disadvantage of GA-ANFIS hybrid algorithm has slow convergence and gradient learning rate, which causes local minima. In [25], Particle Swarm Optimization (PSO)-ANFIS method has implemented for forecasting short-term power from wind. The low error achieved by optimizing the ANFIS membership functions through particle swarm optimized technique which is able to find global optima and has minimum cost function. In [26], BAT algorithm based MPPT technique has discussed for SRM drive applications. The performance of BAT search algorithm tested under Chan solar irradiance, temperature, and step load variations. However, the performance testing has not been implemented using hardware interface. In [27], ABC based MPPT implemented for PV DC Drive application provides excellent performance under varying irradiance level, temperature, and load torque. Nevertheless, the practical realization of this algorithm not addressed. In [28], hybrid ANN associated time variable based delay has been discussed which explains greater leveled non-deterministic as well as decreased stochastic shifting. Moreover, these two signals have been employed with hierarchal ANN method which depends on time dependent delay. In [29], state estimation for discrete period based ANN using MPDT shifting as well as combined delay has been discussed which provides

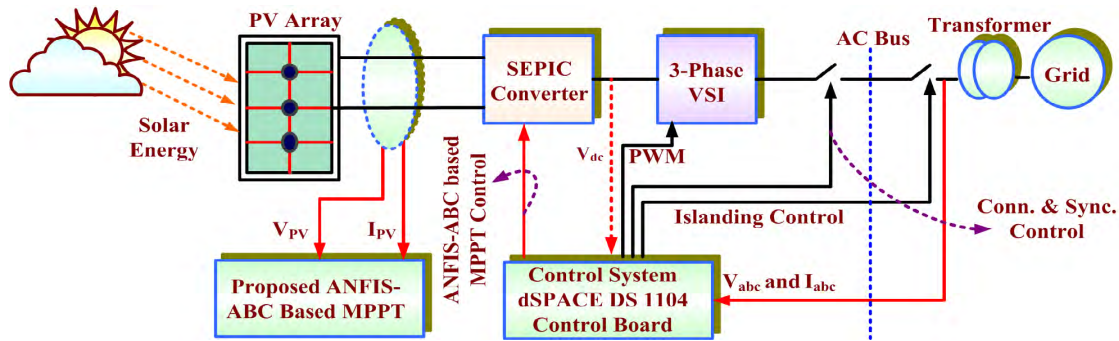

FIGURE 1. Proposed grid connected PV system structure and control.

high filtered behavior by increasing channels number. The ANFIS algorithm, combines the ANN based learning and FLC based decision making algorithms. The various optimization methods like GA, PSO have been used for ANFIS training, which are based on least square and back propagation techniques. Compared to GA and PSO based optimized algorithm, ABC is a recent swarm intelligence method which requires less controlling parameters with a simple implementation. The parameters of ANFIS membership function is optimally tuned using ABC successfully with superior state of art. Furthermore, the ABC method has the remarkable potential to solve complex optimization complications and provides proper training of ANFIS structure by identification of the non-linear static and dynamic model. The employed ABC method is a recent swarm technique which contains minimum deciding variables compared to GA and PSO based optimization methods with a simpler implementation. That is why; authors have selected ABC method as an optimization tool employed with ANFIS for searching and adjustment of ANFIS architecture's optimal parameters as well as membership functions of ANFIS controller, respectively. This paper deals the practical realization of hybrid ANFIS ABC based grid integration of MPPT algorithm and the hybrid ANFIS-ABC will provide better PV tracking efficiency, rapid dynamic responses, high convergence speed, and robust flexible design under varying weather conditions.

The technical contribution of this research work is an extensive mathematical analysis of ANFIS-ABC based MPPT has been discussed which provides optimal tuning of ANFIS membership functions with reduced root mean square error (RMSE). The proposed ANFIS-ABC based MPPT method has been compared with employed PV based grid-tied system and equated with ANFIS-GA and ANFIS-PSO methods.

This paper deals the practical realization of hybrid ANFIS ABC based grid integration of MPPT algorithm and the hybrid ANFIS-ABC will provide better PV tracking efficiency, rapid dynamic responses, high convergence speed, and robust flexible design under varying weather conditions.

In this research paper, the extensive experimental analysis of Hybrid ANFIS-ABC based MPPT for PV grid integration

with anti-islanding protection scheme been discussed. This novel research work mainly focuses on high tracking efficiency of the proposed grid integration with anti-islanding. MATLAB/Simulink model of MPPT and inverter control has practically linked with dSPACE platform. The novelty of this paper is ANFIS-ABC based PV MPPT with anti-islanding protection to the grid integration have neither been developed nor discussed using dSPACE software before by author's best knowledge.

II. PROPOSED GRID CONNECTED PV SYSTEM DESCRIPTION

The complete PV-utility grid control structure is described in Fig. 1. The ANFIS-ABC MPPT and FLC inverter control been employed for PWM pulse generation. The MATLAB/Simulink model of proposed controllers practically interfaced with dSPACE control board. ANFIS membership functions are optimized using an artificial swarm ABC technique. Fuzzy logic based inverter control strategy has been implemented, which injects pure sinusoidal current to the utility grid. The proposed PV grid connected system protected from islanding effect.

A. PV CELL MODELING

In order to model PV cell, the double exponential PV cell equivalent circuit is needed [8]. It consists of a dc source in parallel with two diodes and two resistances (R_S and R_{SH}), which is shown in Fig. 2. The estimated current is as follows:

$$I = I_{PV} - I_{D1} - I_{D2} - \frac{V_o + IR_S}{R_{SH}} \quad (1)$$

$$I_{D1} = I_{01} \left[\exp \left(\frac{q(V_o + IR_S)}{AkT_C} \right) - 1 \right] \quad (2)$$

$$I_{D2} = I_{02} \left[\exp \left(\frac{q(V_o + IR_S)}{AkT_C} \right) - 1 \right] \quad (3)$$

B. SINGLE ENDED PRIMARY ENDED CONVERTER

Fig. 3 depicts the circuit configuration of the SEPIC converter. The step-up/step-down operation of the source to load voltage is performed by selecting the appropriate duty cycle (D) of the converter. The duty cycle should match with

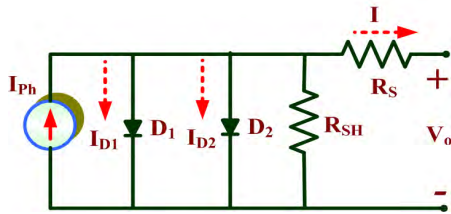

FIGURE 2. Equivalent double exponential PV cell.

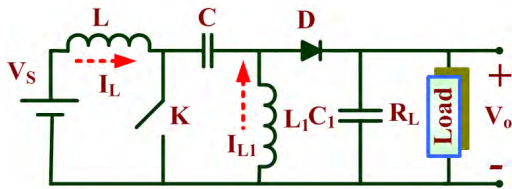

FIGURE 3. Circuit diagram of SEPIC converter.

PV panel variable source impedance to get peak PV power requirement. The SEPIC converter has high power tracking ability and low input current ripple. It converts the positive input voltage to constant positive output, which utilized as open loop controller. Moreover, it step-up and step-down the PV voltage and makes it close to the upper DC voltage level. The SEPIC converter has buck-boost ability due to which it regulates the PV voltage and performs MPPT operation with high tracked efficiency.

C. MODE-1: WHEN SWITCH K IS ON AND DIODE D IS REVERSED BIASED

For this mode, the relationship between the current and voltage obtained as follows:

$$\begin{cases} V_s = L \frac{di_L}{dt}, & L_1 \frac{di_{L1}}{dt} = V_C \\ C \frac{dV_C}{dt} = -i_{L1}, & C_1 \frac{dV_{C1}}{dt} = -\frac{V_o}{R_L} \end{cases} \quad (4)$$

D. MODE-2: WHEN SWITCH K IS OFF AND DIODE D IS FORWARD BIASED

For this mode, the relationship between the current and voltage obtained as follows:

$$\begin{cases} V_s - L \frac{di_L}{dt} - V_C - V_{C1} = 0, & L_1 \frac{di_{L1}}{dt} = -V_{C1} \\ C \frac{dV_C}{dt} = i_L, & C_1 \frac{dV_{C1}}{dt} = i_L + i_{L1} - \frac{V_o}{R_L} \end{cases} \quad (5)$$

III. PROPOSED HYBRID ANFIS-ABC BASED MPPT CONTROLLER

An ANFIS controller comprises the advantages of both neural network and fuzzy logic controllers. Compared to other intelligent techniques of MPPT, the ANFIS based MPPT controller provides high tracking accuracy with fast convergence speed. It has optimized fuzzy membership functions with

similar neural trained data. MATLAB/Simulink implemented ANFIS controller interfaced with a real-time dSPACE control board that generates optimal duty ratio for SEPIC converter. The fuzzy membership functions trained by the back propagation algorithm which produces tuned membership parameters. Linguistic variables transformed into numerical by the application of a fuzzy logic controller. Compared to classical MPPT algorithms, ANFIS based MPPT tracks optimal power with zero oscillation around maximum power point (MPP). The optimal fuzzy rules are obtained by embedding complete system behavior.

The ANFIS based intelligent MPPT controller comprises the advantages of ANN and FLC algorithms and able to handle the non-linear behavior of the PV panel. It provides the rapid dynamic response, high convergence speed and robust flexible design under varying weather conditions. The high tracking efficiency, impedance matching functions between the PV panel and load efficiently achieved by this proposed MPPT controller. By considering the sufficient epochs the input and output map trained data has been set. The inference rule base system decides the appropriate output for varying inputs. After proper adjustment of membership parameters, the learning based ANFIS controller employed as an MPPT algorithm. In this research work, Sugeno 1st order inference system considered that parameters optimized by back propagation and least square method. Fig. 4 depicts the structure of ANFIS based MPPT controller. The ANFIS produces a set of inference fuzzy rules to adjust the assigned membership function until the error reduced and the desired output obtained. The value of the membership function adjusted until the error minimized. It becomes a learning model and works as an MPPT controller when the membership functions adjusted. Moreover, the checking data is compared with trained data, if an error is generated the value of membership function is adjusted until error becomes minimum. In this research work, 200-trained data with 100 epoches been employed, for the purpose of ANFIS training, so that about 5 % training error is reduced.

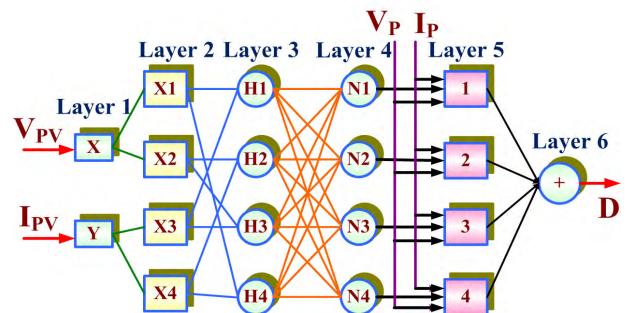

FIGURE 4. Structure of ANFIS MPPT controller.

In this process, the membership functions considered as in Fig. 5 Negative Big (NB), Negative Small (NS), Zero (ZE), Positive Small (PS), and Positive Big (PB). Fuzzy inference rules on which fuzzy decisions made described

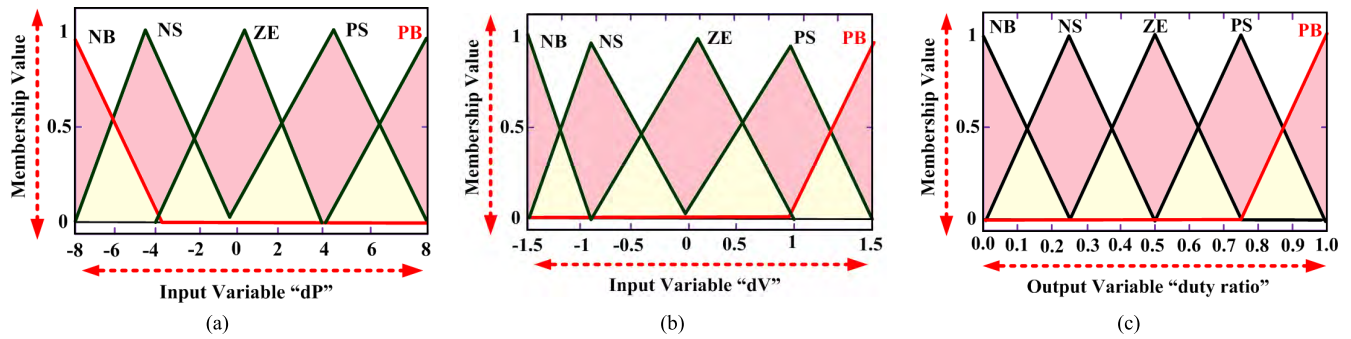

FIGURE 5. Membership function (a) change in power, (b) change in voltage, and (c) duty ratio.

TABLE 1. Inference rule base for fuzzy controller.

dV	dP				
	NB	NS	ZE	PS	PB
NB	PS	PB	ZE	NB	NS
NS	PB	NS	PB	PS	ZE
ZE	NS	ZE	PS	ZE	PB
PS	PS	PB	NS	PS	PS
PB	ZE	NS	NB	PB	ZE

in Table 1. The fuzzy logic controller comprises fuzzifier, rule base and defuzzifier as major control blocks. The inputs error and change in error processed through fuzzification block. The membership functions assigned so that the inputs are fuzzified. Fuzzy inference rules, based on IF/THEN statement is processed and fuzzy decisions carried out. The centroid method employed for defuzzification that gives the desired duty ratio. The mean value of weight calculated mathematically as:

$$W = \frac{\sum_{i=1}^N W_i \times \mu(W_i)}{\sum_{i=1}^N W_i \times \mu(W_i)} \tag{6}$$

The membership functions optimized and tuned by application of back-propagation and least square algorithm. Here, a Hybrid ANFIS-ABC based algorithm proposed for optimal tuning of ANFIS membership function. Employed, Onlookers and Scouts bees are the major components of ABC. Employed and Onlookers bees are the first and second half of the colony, respectively. The food sources searched by employed bees and then the source of information provided to Onlookers bees with quality probability proportion. New food sources are searched randomly by scouts' bees to provide the optimal solution by adjusting fitness function. The optimal solution obtained by finding every food source position. The employed bees should be equal to total food sources. Considering, N_S be the total food source and $R_{1i}, R_{2i}, R_{3i}, \dots, R_{Pi}$ locates the position of i^{th} food source, P is total optimizing parameters. Fitness function mathematically

written as:

$$F(R_i) = \begin{cases} \frac{1}{1 + f(R_i)}, & f(R_i) \geq 0 \\ 1 + f(R_i), & f(R_i) \leq 0 \end{cases} \tag{7}$$

$$Pr(R_i) = \frac{F(R_i)}{\sum_{n=1}^{NS} F(R_n)} \tag{8}$$

Initially, the NS solution of the population crossed using employed, and onlooker and scout bees step under repeated cycles, follow the relation:

$$V_{Qj} = X_{ij} + R_{ij} (X_{ij} - X_{Qj}) \tag{9}$$

In terms of the lower and higher limit, the random position solution expressed as:

$$X_{ij} = X_{M \text{ in } j} + \text{Random} [01] (X_{Max \text{ j}} - X_{M \text{ in } j}) \tag{10}$$

The ANFIS parameters assumed as a single food source, which provides the optimal solution with affecting ANFIS parameters as each food source dimensions. In this research work, the linguistic hedges (L) of membership function as an antecedent and rule output c as a consequent parameter selected for optimization. Antecedent parameters expressed mathematically as:

$$R = \left(\mu_{is}^{Gaussian}, \quad s \in S, i \in I \right) \tag{11}$$

Each rule outcome of the consequent parameter represented by a linear membership function, which expressed mathematically as:

$$R = \mu_S^{Linear} \mid s \in S \tag{12}$$

Finally, one food source dimension using ANFIS-ABC method expressed as:

$$R = \left(\mu_{is}^{Gaussian}, \quad \mu_s^{Linear} \mid s \in S, i \in I \right) \tag{13}$$

The complete structure of Hybrid ANFIS-ABC control is depicted in Fig. 6. The required objective function is found



FIGURE 6. Complete structure of Hybrid ANFIS-ABC control.

to reduce the ANFIS root mean square error (RMSE) mathematically represented as:

$$RMSE = \sqrt{\sum_{i=1}^N \frac{(\bar{Y}_i - Y_i)^2}{N}} \quad (14)$$

IV. THREE PHASE VSI CONTROL

The fuzzy logic based three-phase inverter control strategy [30], [31] is discussed using Fig. 7 for PV grid integration. It comprises of voltage control, current control, system protection, detection of grid changes, and generation of PWM gating signal. In voltage control operation, V_{dc} and V_{dcref} have compared, and obtained output regulated by the fuzzy logic controller. Moreover, I_{dref} tracked in operation of current control mode. The proposed control system performs the functions of efficient control of SEPIC to obtain MPP with zero power oscillation. To obtain synchronized inverter as well as utility grid voltage. Efficient controlling of utility grid integration with PV has been provided for anti-islanding protection purpose.

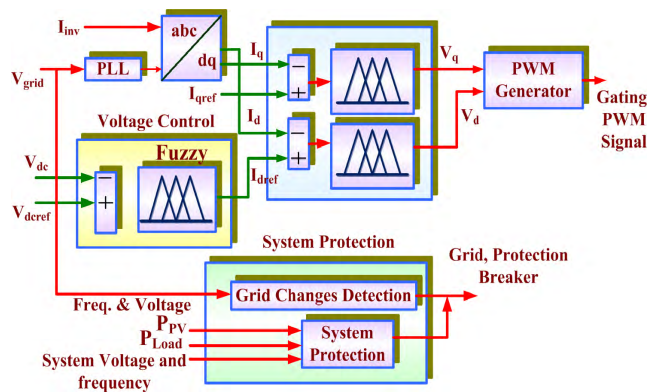

FIGURE 7. Inverter control strategy.

In this research work, 10 kHz switching frequency considered for the triangular signal. The proposed control design provides over and under voltage protection with varying frequency. Under abnormal operating conditions, the circuit breaker gets cut-off and it provides isolation to the inverter

circuit with the utility grid. The Phase Locked Loop (PLL) employed to measure the voltage and frequency of synchronized inverter as well as the grid. Compared to bell-shaped membership functions, the triangular membership function is simpler, flexible and easy for arithmetic operation. Therefore, triangular membership function is used in this paper. The V_d and V_q components act as inputs to the PWM generator so that required PWM pulses have been obtained. PWM signal can be generated by comparing measured signal (V_q and V_d) and a reference signal, which results in PWM signal generation.

The dSPACE DS1104 real-time board employed for the purpose of inverter control. The proposed controller makes the system protected from over/under voltage as well as frequency variation. During system protection, the inverter disconnected from utility grid under transient operating conditions. Inverter frequency synchronized with grid frequency in case of mode of grid connection, which is done using PLL. Once grid synchronization achieved, breaker plays an important role to control grid connection.

In case of standalone mode of operation, the inverter works in voltage control mode and fed power to AC load. The park’s transformation employed to convert the sensed inverter output voltage to dq components. Therefore, under steady and dynamic operating conditions, the inverter tracks voltage reference and maintain inverter’s output (voltage) and frequency. After inverter grid synchronization, the circuit breaker makes the grid connection. Under the current control mode (Grid-connected scheme), the proposed FLC controller tracks the current reference. I_d and I_q currents combined with I_{dref} and I_{qref} current obtained in the voltage control mode of operation to produce an error. Moreover, the error generated by comparing V_{dc} to V_{dcref} has fed to FLC controller, which produces I_{dref} component associated with previously obtained I_d current. Under abnormal operating conditions, the circuit breaker open contact and inverter switched off and disconnected from the utility grid. The safety priorities maintained under grid disturbance. The grid voltage increased/decreased by more than 110% and less than 88%, the frequency increment/decrement will be more than 51 Hz and less than 49 Hz, respectively. The I_d and I_q currents employed to control active and reactive power according to the theory of instantaneous power and expressed by relations:

$$\begin{cases} P_{active} - \frac{3}{2} [v_d \times i_d + [v_q \times i_q]] = 0 \\ Q_{reactive} - \frac{3}{2} [v_q \times i_d - [v_d \times i_q]] = 0 \end{cases} \quad (15)$$

V. ANTI-ISLANDING PROTECTION CONTROL

The classical anti-islanding methods are unable to identify islanding condition at power balanced situations. However, the proposed anti-islanding method drives the frequency/voltage at point of common coupling far away from preset value naturally. The Phase Locked Loop (PLL) measures the phase angle and operating frequency of grid voltage [17]. Fig. 8 depicts the overall anti-islanding protection scheme of the proposed grid-connected PV system. For the purpose

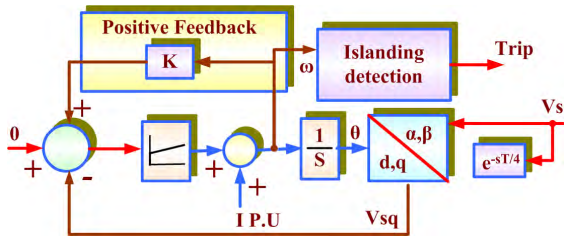

FIGURE 8. Anti-Islanding protection scheme.

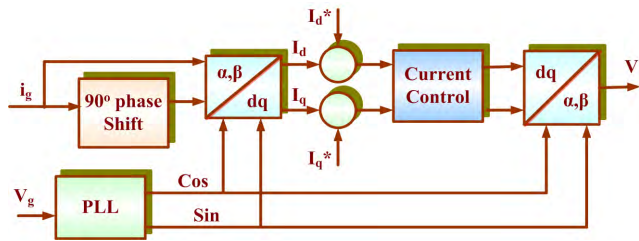

FIGURE 9. Working of Phase Locked Loop (PLL) Operation.

of protection as well as grid connection, these parameters applied to the controller. The positive feedback loop inserted to vary the phase angle under grid off connecting mode. PLL employed to track the grid frequency and able to attenuate and synchronize grid variations as shown in Fig. 9. PLL detects grid voltage/frequency, which provides grid synchronization and delivers $\sin(\omega t)$ and $\cos(\omega t)$ components as the referred frequency for the derivation of abc to dq translation Park's transformation are employed to convert 3-phase inverter current (abc frame) to dq. The fuzzy logic control block is able to provide the pathway for V_{ref} (Reference voltage) in changing operating conditions, which results in stabilization of inverter voltage/frequency. As the result of this, the frequency of converter changes $> 2\%$. The system becomes automatically off that validates the anti-islanding protection of the system. In the case of grid-connected mode, a small variation in phase and frequency operated. Initially, PLL component delivers sine wave as a reference constituent. The contribution of controllers in anti-islanding scheme is to provide automatic control of voltage/frequency at PCC above the preset threshold parameter.

VI. SIMULATION AND EXPERIMENTAL INVESTIGATION

To verify the proposed photovoltaic generation system with a hybrid ANFIS-ABC MPPT for grid integration, the laboratory prototype developed as shown in Fig. 10. Fig. 11 presents the PV tracking of the proposed system using ANFIS, ANFIS-ABC, ANFIS-PSO and ANFIS-GA MPPT controllers which reveals that the employed ANFIS-ABC provides high PV power tracking compared to others MPPT methods verified by simulation methods. Table 2 presents the overall specification employed during the practical realization of grid-integrated hybrid ANFIS-ABC algorithm. The source code of the proposed controller written in C language and using dSPACE tool, embedded to the real-time

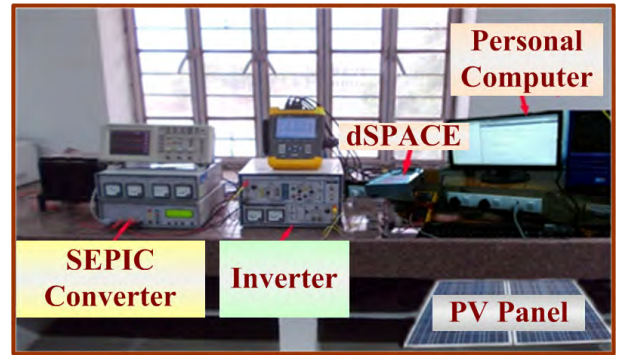

FIGURE 10. Experimental setup of developed PV system.

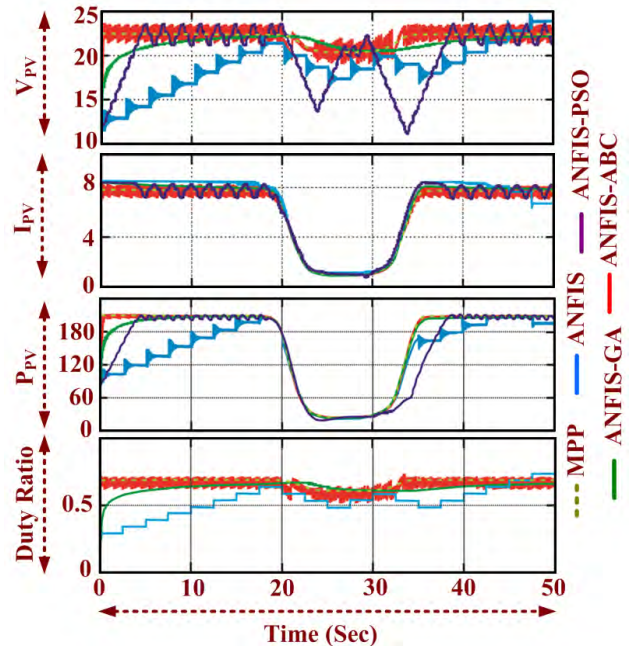

FIGURE 11. Simulation result of proposed PV system using ANFIS, ANFIS-PSO, ANFIS-GA, and ANFIS-ABC.

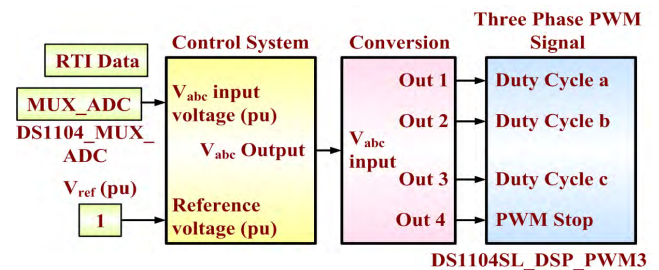

FIGURE 12. MATLAB/Simulink model of the block control system dSPACE DS1104.

DS1104 board. The adaptation of control system is done by the connecting power converter to the dSPACE using interface card. The MATLAB/Simulink model of the block control system dSPACE DS1104 control board as inverter controller is presented in Fig 12.

TABLE 2. Experimentation specifications.

Parameters	Values
Inductor ($L=L_1$)	0.2mH
Capacitors (C,C_1)	1 μ F,670 μ F
Switching Frequency (f_s)	10 kHz
Employed bees number	50
Onlooker bees number	50
Total food source	100

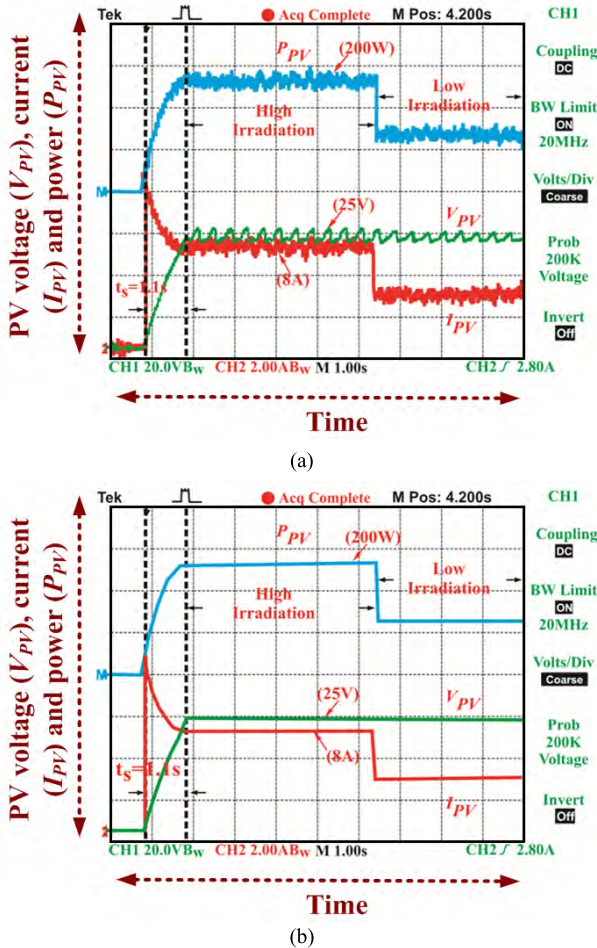

FIGURE 13. Practical PV voltages, current and power during transient environmental conditions (a) Conventional ANFIS control (b) Proposed control.

Fig. 13(a)-13(b) depicts the practical PV voltage, current, and power during transient environmental conditions by using conventional ANFIS and proposed control strategies, respectively. The proposed controller works accurately and provides high tracking efficiency with fast convergence speed. Experimental results of the proposed MPPT and inverter controllers show that the PV power system ensures the active/reactive power compensation, unity pf, less THD with high accuracy. Fig. 14 describes grid voltage and inverter voltage under grid connection operation. Experimental responses justify unity pf operation effectively with synchronized utility grid and inverter voltage. By application of proposed controller, the inverter injects high-quality current to the

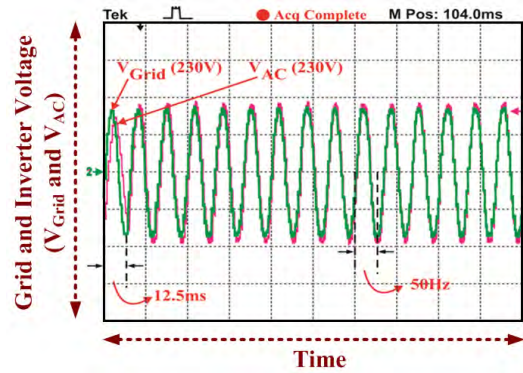

FIGURE 14. Experimental results of grid and inverter under grid connected mode.

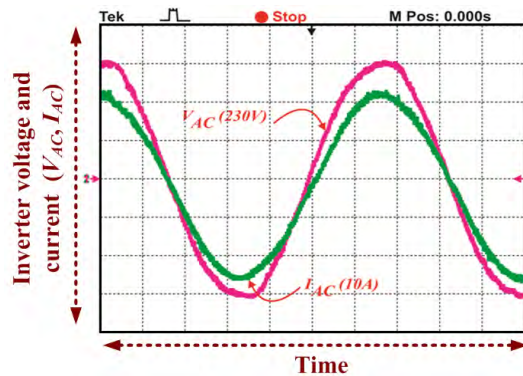

FIGURE 15. Inverter voltage/current practically obtained for a-phase.

utility grid to maintain the active and reactive power with good accuracy. Experimentally obtained sinusoidal inverter voltage/current waveform depicted in Fig. 15. The obtained practical responses completely verified with high accuracy, which provides optimal power with zero oscillation. The controlling capability of the reactive power of the proposed controller explained in Fig. 16, where active power is well maintain with constant reactive power. The experimental responses completely verify the effectiveness of the ability of reactive power control for the grid-connected PV power system.

FFT analysis of 3-ph grid voltage/current done and the THD values of grid voltage and grid current experimentally obtained as 2.3% and 2.5%, respectively. It confirmed and satisfies the IEEE 519 grid code and depicted in Fig. 17. Fig. 18(a) describes the practical responses of the converter output voltage and grid current. From experimental results, it is clear that when grid switched off at time t , the anti-islanding protection of converter starts operating and it stops working under 150% more loading condition. Anti-islanding protection of the converter is operating when 50% power loading condition is applied that is explained in Fig. 18(b). The practical responses are completely complying with IEEE grid code.

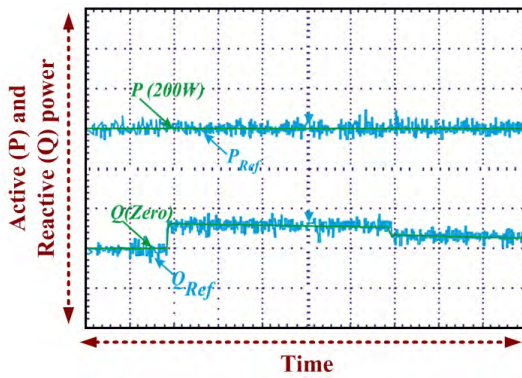
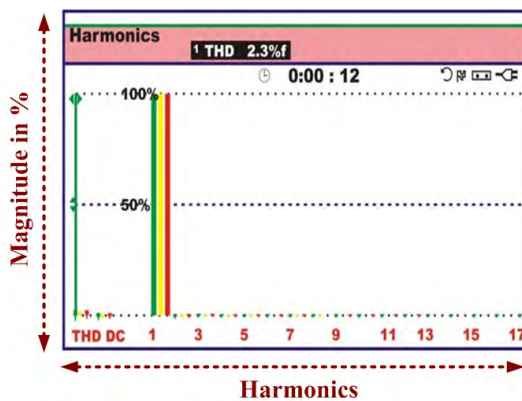
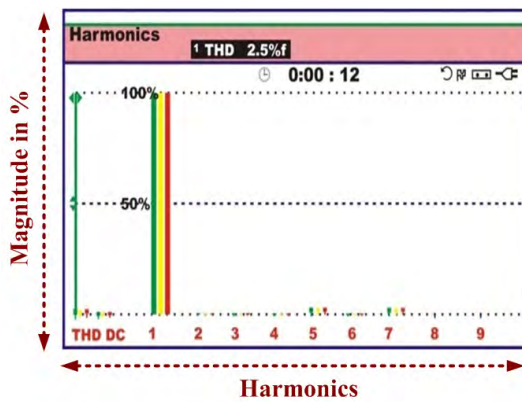

FIGURE 16. Practical results of active and reactive power.



(a)



(b)

FIGURE 17. THD spectrum of (a) Grid voltage, (b) Grid current.

The practical responses described in Fig. 19 reveals that the proposed inverter injects pure sinusoidal current to the electric grid and has less harmonic distortion. A small steady-state error and high PV tracked power obtained under a short convergence period. Moreover, the smooth DC link current obtained using the proposed controller.

Fig. 20 and Fig. 21 present the practically obtained inverter voltage/current under unity/lagging power factor, respectively, which completely justify the effectiveness of the proposed controller design. The experimentally obtained

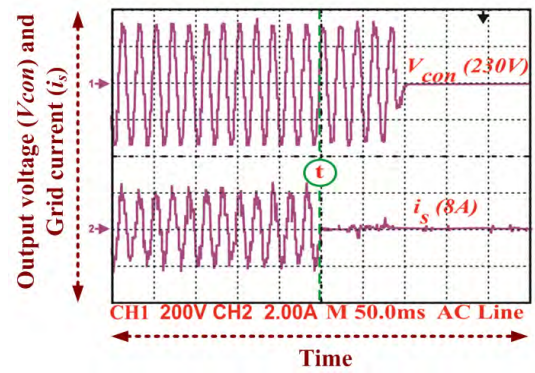

(a)

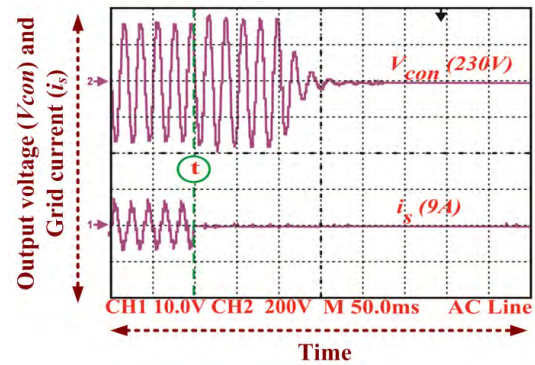

(b)

FIGURE 18. Practical responses of converter output voltage and grid current (a) 150% power loading condition, (b) 50% power loading condition.

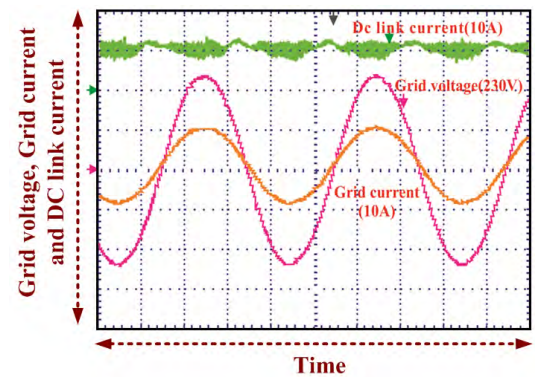

FIGURE 19. Experimental results of grid voltage, grid current and DC link current.

PWM switching pulses for six switches of 3-phase inverter described in Fig.22. From experimental results, it reveals that the proposed controller makes the system a highly tracked and efficient with good performance characteristics.

The experimental results excellently matched with simulated responses with negligible steady state error under steady and dynamic conditions. The performance of ANFIS-GA, ANFIS-PSO and proposed ANFIS-ABC methods have been equated for PV based MPPT for grid integration. Fig. 23 demonstrates that the proposed ANFIS-ABC method

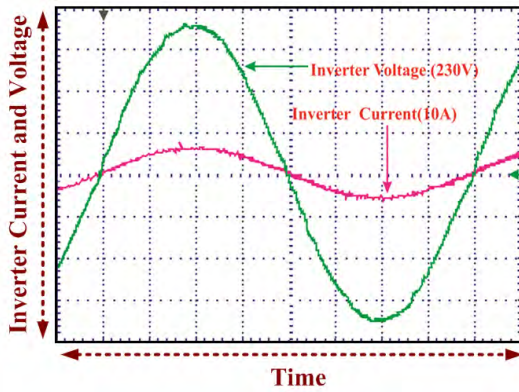

FIGURE 20. Inverter voltage/current under unity power factor operation.

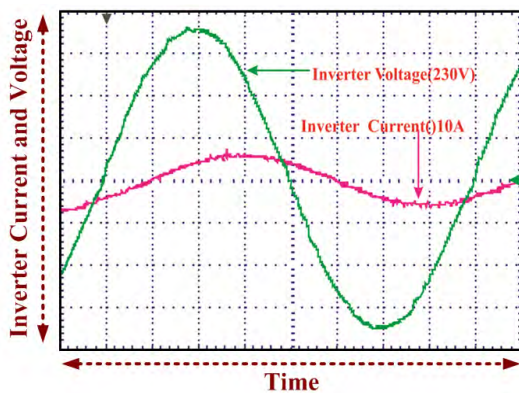

FIGURE 21. Inverter voltage/current under lagging power factor.

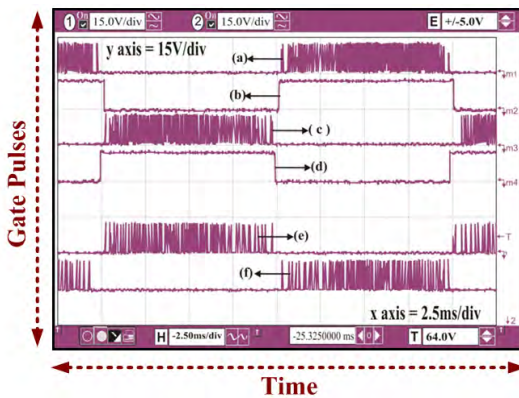

FIGURE 22. dSPACE generated 3-ph PWM inverter pulses.

has high PV tracking ability under partial shading conditions with zero oscillations nearer to MPP region equated with ANFIS-GA and ANFIS-PSO methods based MPPT. Fig 24 depicts the input patterns with varying sun insolation level applied to the proposed PV power system and PV tracking period has been calculated using ANFIS-GA, ANFIS-PSO and ANFIS-ABC methods which presented in Fig 25. Table 3 presents comparison of PV power tracking

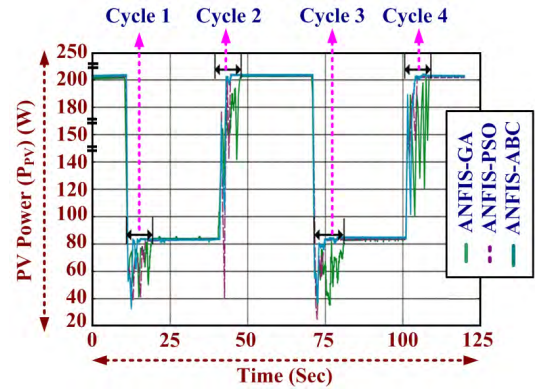

FIGURE 23. PV MPPT tracking comparisons using ANFIS-GA, ANFIS-PSO and proposed ANFIS-ABC.

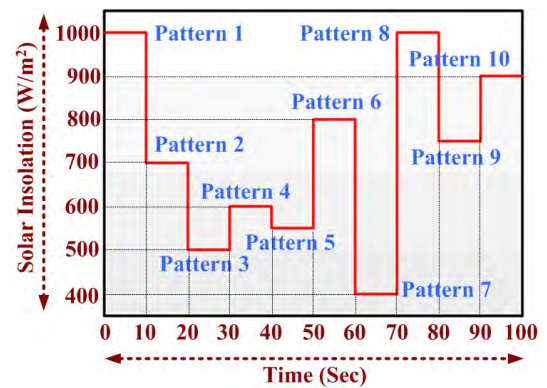

FIGURE 24. Pattern showing variation in sun insolation level.

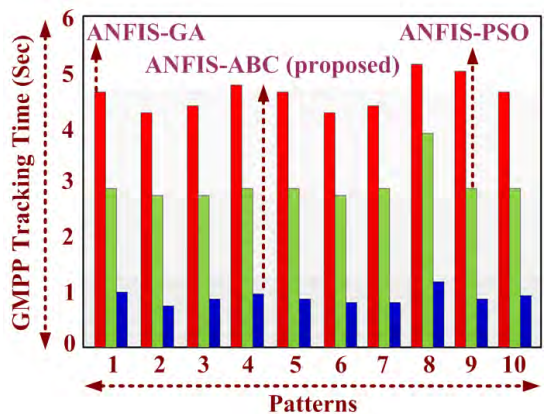

FIGURE 25. Comparison of tracking period of ANFIS-ABC, ANFIS-PSO and ANFIS-GA.

efficiency of the proposed ANFIS-ABC controller versus ANFIS-GA and ANFIS-PSO controller. Table 3 reveals that the proposed ANFIS-ABC MPPT controller has high PV tracking power capability with respect to others presented MPPT methods. The ANFIS-ABC has least convergence period for PV power tracking compared to ANFIS-PSO and ANFIS-GA algorithms. Based on the implementation [32],

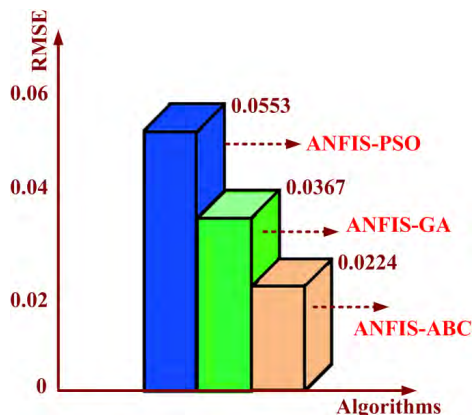

FIGURE 26. Comparison of RMSE of ANFIS-ABC, ANFIS-PSO and ANFIS-GA.

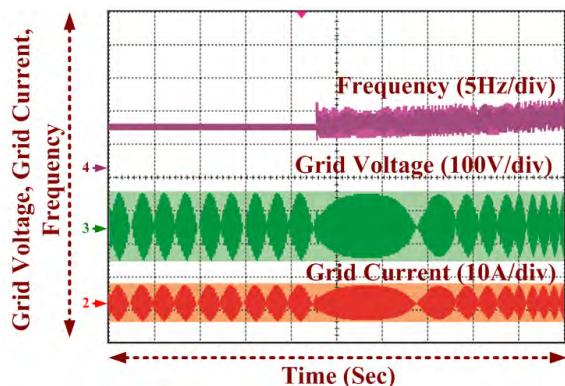

FIGURE 27. Grid voltage and grid current under over and underfrequency.

TABLE 3. PV power tracking efficiency.

Algorithms	Cycle				Average
	I	II	III	IV	
ANFIS-GA	96.33	93.69	96.32	92.61	94.73
ANFIS-PSO	98.72	94.73	98.63	97.93	97.50
ANFIS-ABC (Proposed)	99.68	97.50	98.85	97.55	98.39

in this paper size of population, limitation and peak cycle controlling variables are taken as 20, 250 and 5000 respectively for estimation of RMSE using ANFIS-ABC controller. The obtained RMSE parameters using ANFIS-ABC, ANFIS-PSO and ANFIS-GA are 0.0224, 0.0367 and 0.0553, respectively and presented in Fig. 26 using [32]. PLL provides extra small signal components in which outcomes have drifted and are following exponential characteristics in case of anti-islanding situations. It provides anti islanding protection under over and under frequency and experimental results presented in Fig. 27.

VII. CONCLUSION

The experimental realization of PV grid power system with proposed MPPT and inverter with anti-islanding protection has been accomplished. The SEPIC based MPPT

control system employed with hybrid ANFIS-ABC swarm intelligent control. The optimal power from PV module tracked with an injection of the sinusoidal inverter current to the electric grid under variable environmental conditions. Numerical simulation using MATLAB/Simulink based MPPT and inverter model has been linked with dSPACE platform experimentally. The results obtained from real testing validate the optimal tracking ability. As well as accurate anti-islanding, operation under variable operating conditions with grid voltage and grid current THD 2.3% and 2.5%, respectively. Obtained results always shown clear agreement with the developed theoretical hypotheses. The proposed ANFIS-ABC MPPT method provides high (98.39 %) PV tracking efficiency compared to ANFIS-PSO as well as ANFIS-GA methods. The present work might be extended to multilevel inverter topology with the Internet of Things (IoT) as well as machine learning based advanced MPPT innovations for future investigations.

REFERENCES

- [1] E. Afshari, G. R. Moradi, R. Rahimi, B. Farhangi, Y. Yang., F. Blaabjerg, S. Farhangi, "Control strategy for three-phase grid-connected PV inverters enabling current limitation under unbalanced faults," *IEEE Trans. Ind. Electron.*, vol. 64, no. 11, pp. 8908–8918, Nov. 2017.
- [2] M. J. Z. Zadeh and S. H. Fathi, "A new approach for photovoltaic arrays modeling and maximum power point estimation in real operating conditions," *IEEE Trans. Ind. Electron.*, vol. 64, no. 12, pp. 9334–9343, Dec. 2017.
- [3] K. Chandramohan, S. Padmanaban, R. Kalyanasundaram, M. S. Bhaskar, and L. Mihet-Popa, "Grid synchronization of a seven-phase wind electric generator using $d - q$ PLL," *Energies*, vol. 10, no. 7, p. 926, Jul. 2017.
- [4] N. Kumar, I. Hussain, B. Singh, and B. K. Panigrahi, "Maximum power peak detection of partially shaded PV panel by using intelligent monkey king evolution algorithm," *IEEE Trans. Ind. Appl.*, vol. 53, no. 6, pp. 5734–5743, Nov./Dec. 2017.
- [5] N. Kumar, I. Hussain, B. Singh, and B. K. Panigrahi, "MPPT in dynamic condition of partially shaded PV system by using WODE technique," *IEEE Trans. Sustain. Energy*, vol. 8, no. 3, pp. 1204–1214, Jul. 2017.
- [6] N. Kumar, I. Hussain, B. Singh, and B. K. Panigrahi, "Rapid MPPT for uniformly and partial shaded PV system by using JayaDE algorithm in highly fluctuating atmospheric conditions," *IEEE Trans. Ind. Informat.*, vol. 13, no. 5, pp. 2406–2416, Oct. 2017.
- [7] S. B. Mahajan, S. Padmanaban, and F. Blaabjerg, "A multistage DC-DC step-up self-balanced and magnetic component-free converter for photovoltaic applications: Hardware implementation," *Energies*, vol. 10, no. 5, p. 719, May 2017.
- [8] A. Lashab, D. Sera, J. M. Guerrero, L. Mathe, and A. Bouzid, "Discrete model-predictive-control-based maximum power point tracking for PV systems: Overview and evaluation," *IEEE Trans. Power Electron.*, vol. 33, no. 8, pp. 7273–7287, Aug. 2018.
- [9] A. A. S. Mohamed, A. Berzoy, and O. A. Mohammed, "Design and hardware implementation of FLMPPT control of PV systems based on GA and small-signal analysis," in *Proc. IEEE Power Energy Soc. Gen. Meeting*, Chicago, IL, USA, Jul. 2017, p. 1.
- [10] S. Padmanaban, M. S. Bhaskar, P. K. Maroti, F. Blaabjerg, and V. Fedák, "An original transformer and switched-capacitor (T & SC)-based extension for DC-DC boost converter for high-voltage/low-current renewable energy applications: Hardware implementation of a new T & SC boost converter," *Energies*, vol. 11, no. 4, p. 783, Apr. 2018.
- [11] H. Taheri and S. Taheri, "Two-diode model-based nonlinear MPPT controller for PV systems," *Can. J. Elect. Comput. Eng.*, vol. 40, no. 2, pp. 74–82, 2017.

- [12] S. Padmanaban, N. Priyadarshi, J. B. Holm-Nielsen, M. S. Bhaskar, F. Azam, A. Sharma, and E. Hossain, "A novel modified sine-cosine optimized MPPT algorithm for grid integrated PV system under real operating conditions," *IEEE Access*, vol. 7, pp. 10467–10477, 2019.
- [13] M. T. Azary, M. Sabahi, E. Babaei, and F. A. A. Meinagh, "Modified single-phase single-stage grid-tied flying inductor inverter with MPPT and suppressed leakage current," *IEEE Trans. Ind. Electron.*, vol. 65, no. 1, pp. 221–231, Jan. 2018.
- [14] A. Saidi and C. Benachaiba, "Comparison of IC and P&O algorithms in MPPT for grid connected PV module," in *Proc. 8th Int. Conf. Modeling, Identificat. Control (ICMIC)*, Algiers, Algeria, Nov. 2016, pp. 213–218.
- [15] S. Sangeetha and J. Joseph, "Design and implementation of SEPIC converter based PV system using modified incremental conductance algorithm," in *Proc. Int. Conf. Elect., Electron., Optim. Techn. (ICEEOT)*, Chennai, India, vol. 16, Mar. 2016, pp. 1262–1267.
- [16] A. G. Al-Gizi, A. Craciunescu, and S. J. Al-Chlahawi, "The use of ANN to supervise the PV MPPT based on FLC," in *Proc. 10th Int. Symp. Adv. Topics Elect. Eng. (ATEE)*, Bucharest, Romania, Mar. 2017, pp. 703–708.
- [17] N. Priyadarshi, S. Padmanaban, P. K. Maroti, and A. Sharma, "An extensive practical investigation of FPSO-based MPPT for grid integrated PV system under variable operating conditions with anti-islanding protection," *IEEE Syst. J.*, vol. 13, no. 2, pp. 1861–1871, Jun. 2018.
- [18] U. K. Renduchintala, C. Pang, S. V. Pavan, K. Maddukuri, and K. M. Tatikonda, "Comparison of MPPT techniques for SEPIC converter based photovoltaic system," in *Proc. Online Int. Conf. Green Eng. Technol. (IC-GET)*, Coimbatore, India, vol. 16, Nov. 2016, pp. 1–5.
- [19] X. Duan and H. Zhang, "Quasi-proportional resonant control of the LCL-type grid-connected inverter based on fuzzy control and self-tuning of fuzzy parameters," in *Proc. 29th Chin. Control Decis. Conf. (CCDC)*, Chongqing, China, May 2017, pp. 1793–1797.
- [20] A. F. B. Filho, A. Ortiz, L. P. dos Santos, F. E. Carvalho, J. S. B. Lopes, and W. L. A. da Silva, "Bilinear predictive controllers applied in an induction motor machine," *IEEE Latin Amer. Trans.*, vol. 15, no. 4, pp. 613–618, Apr. 2017.
- [21] A. S. Mir and N. Senroy, "Adaptive model predictive control scheme for application of SMES for load frequency control," *IEEE Trans. Power Syst.*, to be published.
- [22] B. Wang, J. Xu, R.-J. Wai, and B. Cao, "Adaptive sliding-mode with hysteresis control strategy for simple multimode hybrid energy storage system in electric vehicles," *IEEE Trans. Ind. Electron.*, vol. 64, no. 2, pp. 1404–1414, Oct. 2017.
- [23] N. Priyadarshi, S. Padmanaban, M. S. Bhaskar, F. Blaabjerg, and A. Sharma, "Fuzzy SVPWM-based inverter control realisation of grid integrated photovoltaic-wind system with fuzzy particle swarm optimisation maximum power point tracking algorithm for a grid-connected PV/wind power generation system: Hardware implementation," *IET Electr. Power Appl.*, vol. 12, no. 7, pp. 962–971, Apr. 2018.
- [24] A. T. Eseye, J. Zhang, D. Zheng, H. Li, and G. Jingfu, "Short-term wind power forecasting using a double-stage hierarchical hybrid GA-ANFIS approach," in *Proc. IEEE 2nd Int. Conf. Cloud Comput. Big Data Anal. (ICCCBDA)*, Chengdu, China, vol. 17, Apr. 2017, pp. 499–503.
- [25] H. Li, A. T. Eseye, J. Zhang, and D. Zheng, "A double-stage hierarchical hybrid PSO-ANFIS model for short-term wind power forecasting," in *Proc. IEEE GreenTech*, Denver, CO, USA, Mar. 2017, pp. 342–349.
- [26] A. S. Oshaba, E. S. Ali, and S. M. A. Elazim, "MPPT control design of PV system supplied SRM using BAT search algorithm," *Sustain. Energy, Grids Netw.*, vol. 2, pp. 51–60, Jun. 2015.
- [27] A. S. Oshaba, E. S. Ali, and S. M. A. Elazim, "PI controller design using ABC algorithm for MPPT of PV system supplying DC motor pump load," *Neural Comput. Appl.*, vol. 28, no. 2, pp. 353–364, Feb. 2017.
- [28] L. Zhang, Y. Zhu, and W. X. Zheng, "Synchronization and state estimation of a class of hierarchical hybrid neural networks with time-varying delays," *IEEE Trans. Neural Netw. Learn. Syst.*, vol. 27, no. 2, pp. 459–470, Feb. 2016.
- [29] L. Zhang, Y. Zhu, and W. X. Zheng, "State estimation of discrete-time switched neural networks with multiple communication channels," *IEEE Trans. Cybern.*, vol. 47, no. 4, pp. 1028–1040, Apr. 2017.
- [30] Z. A. Ghani, M. A. Hannan, A. Mohamed, and Subiyanto, "Three-phase photovoltaic grid-connected inverter using dSPACE DS1104 platform," in *Proc. IEEE 9th Int. Conf. Power Electron. Drive Syst.*, Singapore, Singapore, Dec. 2011, pp. 447–451.
- [31] M. A. Hannan, Z. A. Ghani, A. Mohamed, and M. N. Uddin, "Real-time testing of a fuzzy logic controller based grid-connected photovoltaic inverter system," in *Proc. IEEE Ind. Appl. Soc. Annu. Meeting*, Vancouver, BC, Canada, Oct. 2014, pp. 1–8.
- [32] D. Karaboga and E. Kaya, "Training ANFIS by using an adaptive and hybrid artificial bee colony algorithm (aABC) for the identification of nonlinear static systems," *Arabian J. Sci. Eng.*, vol. 44, no. 4, pp. 3531–3547, Apr. 2019.



SANJEEVIKUMAR PADMANABAN (M'12–SM'15) received the bachelor's degree in electrical engineering from the University of Madras, India, in 2002, the master's degree (Hons.) in electrical engineering from Pondicherry University, India, in 2006, and the Ph.D. degree in electrical engineering from the University of Bologna, Italy, in 2012. He was an Associate Professor with VIT University, from 2012 to 2013. In 2013, he joined the National Institute of Technology, India, as a Faculty Member. In 2014, he was invited as a Visiting Researcher with the Department of Electrical Engineering, Qatar University, Qatar, funded by the Qatar National Research Foundation, Government of Qatar. He continued his research activities with the Dublin Institute of Technology, Ireland, in 2014. He was an Associate Professor with the Department of Electrical and Electronics Engineering, University of Johannesburg, South Africa, from 2016 to 2018. Since 2018, he has been a Faculty Member with the Department of Energy Technology, Aalborg University, Esbjerg, Denmark. He has authored 300 plus scientific papers and has received the Best Paper cum Most Excellence Research Paper Award from IET-SEISCON'13, IET-CEAT'16 and five best paper award from ETAEERE'16 sponsored Lecture note in Electrical Engineering, Springer book series. He is a fellow Institution of Engineers (FIE'18, India) and a Fellow of the Institution of Telecommunication and Electronics Engineers (FIETE'18, India). He serves as an Editor/Associate Editor/Editorial Board of refereed journal, in particular, the IEEE SYSTEMS Journal, IEEE Access Journal, the *IET Power Electronics*, the *Journal of Power Electronics*, South Korea, and the Subject Editor of the *IET Renewable Power Generation*, of *IET Generation, Transmission and Distribution*, and of *FACTS Journal*, Canada.



NEERAJ PRIYADARSHI received the M.Tech. degree in power electronics & drives from the Vellore Institute of Technology (VIT), Vellore, India, in 2010, and the Ph.D. degree from the Government College of Technology and Engineering, Udaipur, Rajasthan, India. In previous postings, he was with the JK University, Geetanjali Institute, Global Institute, and SS Group, Rajasthan, India. He is currently with the Department of Electrical Engineering, Birla Institute of Technology (Trust), Ranchi, India. He has published more than 40 papers in journals and conferences. His current research interests include power electronics, control systems, power quality, and solar power generation. He is a Reviewer of the *International Journal of Renewable Energy Research*.



MAHAJAN SAGAR BHASKAR (M'15) received the bachelor's degree in electronics and telecommunication engineering from the University of Mumbai, Mumbai, India, in 2011, the master's degree in power electronics and drives from the Vellore Institute of Technology, VIT University, India, in 2014, and the Ph.D. degree in power electronics from the Department of Electrical and Electronic Engineering Science, University of Johannesburg, Johannesburg, South Africa,

in 2019. He was a Visiting Researcher with the Department of Electrical Engineering, Qatar University, Doha, Qatar. He was an Assistant Professor and a Research Coordinator with the Department of Electrical and Electronics Engineering, Marathwada Institute of Technology (MIT), Aurangabad, India. He is currently a Postdoctoral Researcher with his Ph.D. Tutor with the Department of Energy Technology, Aalborg University, Esbjerg, Denmark. He has published scientific papers in power electronics, with particular reference to XY converter family, multilevel DC/DC and DC/AC converter, and high gain converter. He is a Professional Active Member of the IEEE Industrial Electronics, Power Electronics, Industrial Application, and Power and Energy, Robotics and Automation, Vehicular Technology Societies, Young Professionals, various IEEE Councils and IEEE Technical Communities. He is a Reviewer Member of various international journals and conferences, including IEEE and IET. He was a recipient of the Best Paper cum Most Excellence Research Paper Award from IET-CEAT, in 2016, IEEE-ICCPCT, in 2014, and ETAEERE, in 2016 sponsored Lecture note in electrical engineering, Springer book series. He was also a recipient of IEEE ACCESS award Reviewer of Month, in 2019 for his valuable and thorough feedback on manuscripts.



JENS BO HOLM-NIELSEN is currently with the Department of Energy Technology, Aalborg University, and the Head of the Esbjerg Energy Section. On this research, activities established the Center for Bioenergy and Green Engineering, in 2009, where he serves as the Head of the research group. He has vast experience in bio-refinery concepts and biogas production-anaerobic digestion. Implementation projects of Bio-energy systems in Denmark with

provinces and European states. He served as the Technical Advisory for many industries in this field. He has executed many large scale European Union and United Nation projects in research aspects of Bioenergy, bio refinery processes, the full chain of biogas, and Green Engineering. He has authored more than 100 scientific papers. His research interest includes renewable energy - sustainability - green jobs for all. He was a member on invitation with various capacities in the committee for more than 250 various international conferences and Organizer of international conferences, workshops and training programmes in Europe, Central Asia and China.



VIGNA K. RAMACHANDARAMURTHY (SM'12) received the Ph.D. degree in electrical engineering from the University of Manchester Institute of Science and Technology (UMIST), in 2001. He is currently a Professor with the Institute of Power Engineering, Universiti Tenaga Nasional (UNITEN). His research interests include power systems related studies, renewable energy, energy storage, power quality, electric vehicle, and rural electrification. He is the Principal Consultant for

Malaysia's biggest electrical utility, Tenaga Nasional Berhad and has completed more than 200 projects in renewable energy. He has also developed several technical guidelines for distributed generation in Malaysia. He has served as the IET Malaysia Chairman, IET Council Member, Institution of Engineers Malaysia (IEM) Council Member, and IET Younger Members Board representing West Asia, International Professional Registration Advisor, Interviewer and Convenor for Chartered Engineering (UK) in Malaysia. In 2008, he received the IET Mike Sargeant Award for career achievement. In 2009, he received the Institution of Engineers Malaysia (IEM) Young Engineers Award. He is also a Chartered Engineer registered with the Engineering Council of U.K. and a Professional Engineer registered with the Board of Engineers Malaysia.



EKLAS HOSSAIN (M'09-SM'17) received the B.S. degree in electrical & electronic engineering from the Khulna University of Engineering and Technology, Bangladesh, in 2006, the M.S. degree in mechatronics and robotics from the International Islamic University of Malaysia, Malaysia, in 2010, and the Ph.D. degree from the College of Engineering and Applied Science, University of Wisconsin-Milwaukee (UWM). He has been involved with several research projects on renewable energy and grid tied microgrid system at Oregon Institute of Technology,

as an Assistant Professor with the Department of Electrical Engineering and Renewable Energy, since 2015. He has been working in distributed power systems and renewable energy integration for last ten years and he has published a number of research papers and posters in this field. His research interests include modeling, analysis, design, and control of power electronic devices; energy storage systems; renewable energy sources; integration of distributed generation systems; microgrid and smart grid applications; robotics, and advanced control systems. He, with his dedicated research team, is looking forward to explore methods to make the electric power systems more sustainable, cost-effective and secure through extensive research and analysis on energy storage, microgrid systems, and renewable energy sources. He is currently serving as an Associate Editor for IEEE Access. He is also a registered Professional Engineer (PE) in the state of Oregon, USA.

...