

Received June 23, 2019, accepted July 3, 2019, date of publication July 15, 2019, date of current version July 31, 2019.

Digital Object Identifier 10.1109/ACCESS.2019.2928523

# Towards a Green and Self-Powered Internet of Things Using Piezoelectric Energy Harvesting

MAHYAR SHIRVANIMOGHADDAM<sup>1</sup>, (Member, IEEE), KAMYAR SHIRVANIMOGHADDAM<sup>2</sup>,  
MOHAMMAD MAHDI ABOLHASANI<sup>3</sup>, MAJID FARHANGI<sup>4</sup>, VAHID ZAHIRI BARSARI<sup>4</sup>,  
HANGYUE LIU<sup>4</sup>, (Student Member, IEEE), MISCHA DOHLER<sup>5</sup>, (Fellow, IEEE),  
AND MINOO NAEBE<sup>2</sup>

<sup>1</sup>Centre for IoT and Telecommunications, School of Electrical and Information Engineering, The University of Sydney, Sydney, NSW 2006, Australia

<sup>2</sup>The Institute for Frontier Materials, Deakin University, Geelong, VIC 3216, Australia

<sup>3</sup>Chemical Engineering Department, University of Kashan, Kashan, Iran

<sup>4</sup>School of Electrical and Information Engineering, The University of Sydney, Sydney, NSW 2006, Australia

<sup>5</sup>Centre for Telecommunications Research, Department of Informatics, King's College London, London WC2B 4BG, U.K.

Corresponding authors: Mahyar Shirvanimoghaddam (mahyar.shm@sydney.edu.au) and Minoo Naebe (minoo.naebe@deakin.edu.au)

This work was supported in part by the Australian Research Council under the Discovery Project Grant DP180100606, in part by the Australian Research Council World Class Future Fiber Industry Transformation Research Hub under Grant H140100018, and in part by the Australian Research Council Training Centre for Light Weight Automotive Structures (ATLAS).

**ABSTRACT** The Internet of Things (IoT) is a revolutionizing technology which aims to create an ecosystem of connected objects and embedded devices and provide ubiquitous connectivity between trillions of not only smart devices but also simple sensors and actuators. Although recent advancements in miniaturization of devices with higher computational capabilities and ultra-low power communication technologies have enabled the vast deployment of sensors and actuators everywhere, such an evolution calls for fundamental changes in hardware design, software, network architecture, data analytics, data storage, and power sources. A large portion of the IoT devices cannot be powered by batteries only anymore, as they will be installed in hard to reach areas and regular battery replacement and maintenance are infeasible. A viable solution is to scavenge and harvest energy from the environment and then provide enough energy to the devices to perform their operations. This will significantly increase the device life time and eliminate the need for the battery as an energy source. This survey aims at providing a comprehensive study on energy harvesting techniques as alternative and promising solutions to power the IoT devices. We present the main design challenges of the IoT devices in terms of energy and power and provide design considerations for a successful implementation of self-powered the IoT devices. We then specifically focus on piezoelectric energy harvesting as one of the most promising solutions to power the IoT devices and present the main challenges and research directions. We also shed lights on the hybrid energy harvesting for the IoT and security challenges of energy harvesting enabled the IoT systems.

**INDEX TERMS** Energy harvesting, Internet of Things (IoT), RF energy harvesting, piezoelectric.

## I. INTRODUCTION

Recent advancements in miniaturization of devices with higher computational capabilities and ultra-low power communication technologies are driving forces for the ever growing deployment of embedded devices in our surroundings. This will transform every physical object, i.e., *thing*, into an information source with the potential to communicate with every other thing in the network. This ecosystem of connected things are called *Internet of Things (IoT)*.

The associate editor coordinating the review of this manuscript and approving it for publication was Kai Yang.

IoT applications and services cover almost any sector where embedded devices can replace human in performing tasks. Examples are home automation, agriculture, smart cities, industrial automation, healthcare, remote monitoring, and many more. IoT provides a network of connected devices that real time information can be shared and used in order to enhance life quality, improve industry processes, energy efficiency, and level of services. IoT significantly improves supply chain efficiencies and develop new services for retailers [2]. Such a network of inter-connected devices enables the factories to get humans and enterprise systems more involved with the machines in the whole supply chain

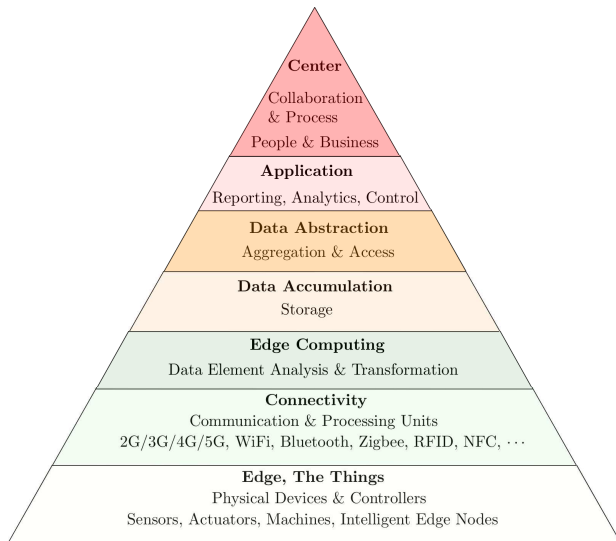

FIGURE 1. IoT world forum reference architecture [1].

system. This will improve the total revenue and improve customer satisfaction, and bring the customer experience into a whole new level. Fig. 1 shows the IoT reference architecture, where the *things* interact with the physical world to capture data which is sent via the communication systems towards the center or clouds for processing and analysis.

Devices in IoT are usually divided into two main categories. *Basic devices* only provide basic services of sensor reading and/or actuation tasks, and some limited support for user interaction. They have basic processing and communication capabilities with limited memory and are usually running with small batteries. Basic devices are usually used in *massive IoT* applications, such as consumer electronics and smart metering. In massive IoT, devices must have very low power consumption and the network should provide long coverage. Also due to the massive scale of the system, the devices should be of low cost and maintenance. On the other hand, *advanced devices* are capable of running complex tasks and usually support cellular and wide area network connections. Examples of advanced devices are smart phones and laptops. These devices are widely used in *critical IoT* applications, with high demands for reliability, availability, and low latency.

Powering the IoT devices is a major challenge, which becomes crucial with the rapid development of relative technologies [3]. In fact in many IoT applications, devices need to be powered in a self-sufficient and sustainable fashion. Most of the devices will be battery operated due to cost, convenience, size, and the fact that they are implemented in hard-to-reach areas. In many IoT applications, long life time of the devices is of prominent need, as the battery maintenance is not feasible due to cost, inconvenience, and the size of the networks. Recent studies showed that more than 3 billion batteries are discarded in the USA every year [4], and the penetration of IoT technologies in every sector will exacerbate this problem.

The trend so far to improve energy efficiency and propose viable solutions for long-life time devices for IoT has been mainly focused on three main directions. First, is to reduce the energy consumption of every component of the device in any operation mode, including embedded sensors, microprocessors, and transceivers. Second, is to increase battery efficiency and have smaller yet more efficient batteries. Third, is to increase the device life time by introducing duty cycling and event-driven communication to reduce the energy usage. While in many cases these trends have achieved significant improvements, there are still major challenges which have not been solved yet. In fact, the IoT applications which only rely on batteries require battery replacement; otherwise node failure will dramatically drop the system performance. Battery replacement is however not a feasible option due to cost and physical operations.

Energy harvesting (EH) provides several solutions for powering IoT. EH techniques harvest energy from different energy sources in the environment, such as thermal, vibrations, solar, and radio frequency (RF) signal energy. This provides a potentially unlimited power supply for IoT devices and significantly increases the device life-time. Energy harvesting market has experienced a huge growth from \$131.4 million in 2012 to \$4.2 billion in 2019.<sup>1</sup> The main reasons behind this growth are 1) the demand for micro-power generation to charge thin film batteries, 2) recent advancements in energy storage devices, i.e., batteries and super-capacitors, 3) the efficiency of EH devices have significantly improved and 4) the fact that the price of super-capacitors and thin-film batteries dramatically decrease. There are also significant cost reductions, which makes them suitable choices for a wide adoption in IoT applications.

Energy harvesting has been widely studied in the context of wireless sensor networks (WSNs) [5] and wireless body area networks (WBANs) [6] in the literature. These studies have mainly focused on 1) energy harvesting technologies [7], [8], 2) power management mechanisms [9]–[11], 3) challenges and practical issues of energy harvesting for WSNs [12], [13], and 4) sensor node design [14]. However, due to unique requirements of emerging IoT applications and the differences between IoT and WSNs in general, there is a major need to study and investigate the EH techniques for the specific uses for IoT. In particular, IoT devices may interact with multiple network tiers to deliver their messages and receive feedbacks and act upon the command received from the network. Also, most studies on EH techniques for WSNs have focused on short-range communication technologies, which might be unsuitable for many IoT applications. In fact, several low-power wide area networks (LPWAN) have been proposed and implemented to provide long coverage and high capacity IoT services. The IoT Global Forecast & Analysis 2015-2025, from Machina Research expects that 11%

<sup>1</sup><https://pitchengine.com/pitches/59354ec3-359e-4476-89ef-2ce639997a21>

**TABLE 1.** Summary of notations commonly used in the paper.

Notation	Definition
CRN	Cognitive Radio Network
D2D	Device-to-Device Communications
EH	Energy Harvesting
ENO	Energy Neutral Operation
IoT	Internet of Things
LPWAN	Low Power Wide Area Network
LTE	Long Term Evolution
MIMO	multiple-input multiple-outpt
mmW	millimetre Wave
MTC	Machine-Type Communications
LTE	Long-Term Evolution
PV	Photovoltaic
PVDF	Polyvinylidene Fluoride
PZT	Lead Zirconate Titanate
RF	Radio Frequency
TEG	Thermal Energy Generator
WBAN	Wireless Body Area Network
WEH	Wireless Energy Harvesting
WSN	Wireless Sensor Network
3GPP	Third Generation Partnership Project

of IoT connections in 2025 to use LPWAN connectivity technologies [15]. This shows the need for the comprehensive study of self-powered solutions for emerging IoT applications which are enabled using LPWAN technologies. This paper reviews several energy harvesting techniques, provides insights on the design of suitable self-powered IoT devices, discusses pros and cons of each EH technique, provides some detailed discussions on the piezoelectric energy harvesting materials and design for self-powered IoT, and finally discusses the future challenges of self-powered IoT. The paper is of survey nature aiming at paving the path to a green and sustainable IoT ecosystem. A summary of notations commonly used in the paper is presented in Table 1.

The remainder of the paper is organized as follows. In Section II, we briefly introduce Internet of Things and different applications and requirements. Section III provides a comprehensive overview of energy in the IoT ecosystem, where we also discuss about IoT devices, energy harvesting techniques, and energy harvesting use cases in IoT. In Section IV, we focus on piezoelectric energy harvesting and provide a comprehensive study on piezoelectric effect, mode of use, piezoelectric materials, and discuss the design consideration of piezoelectric EH for IoT applications. In Section V, we focus on hybrid energy harvesting and some new directions in the design of EH-enabled IoT systems. Security challenges of EH-enabled IoT systems are discussed in Section VI. Energy harvesting market perspective is provided in Section VII followed by some concluding remarks in Section VIII.

## II. AN OVERVIEW ON IOT

Internet of Things has attracted enormous attention from both industry and research sectors. This is mainly because of huge opportunities that IoT will create in the near future. IoT goes beyond personal computers and mobile phones, and converts

every physical object to an information source and connect them to the Internet or local area networks. IoT services are mainly categorized into *massive IoT* and *critical IoT*. In massive IoT, countless devices will send data to the servers via Internet or local networks. The devices therefore should operate with low power, low complexity, and of course must be of low cost. Critical IoT has completely different requirements such as, high reliability, availability and low latency; therefore more complex devices are required. Remote health care and traffic safety and control are examples of critical IoT services.

The third generation partnership project (3GPP) has identified 4 different application family types for IoT. These include [16]:

**Type 1** is tracking, assisted living, remote health monitoring, wearables and bicycle tracking. They require 5 years battery life, which can be also supported by energy harvesting for battery recharging, medium coverage, and latency of about 30 seconds (lower latency of 5 seconds is required for some tracking applications). They also require high mobility support. Wearable devices, such as smart watches and fitness monitors, which have longevity requirement of several days as the number of them per user is small and they can be regularly recharged. Many IoT devices are set-and-forth devices, such as home security, with the longevity requirement of several years and a user may have dozens of them, so regular replacement of batteries is inconvenient [4]. Some devices are battery-less and self powered, such as RFID tags and smart cards.

**Type 2** is industrial asset tracking, microgeneration, agricultural livestock and environmental near real time monitoring. They require 5 to 10 years battery life time, latency of less than 1 seconds, and medium coverage.

**Type 3** mainly requires deep indoor coverage for smart metering, smart parking, smart building, home automation, and industrial machinery control. It also requires extended outdoor/rural coverage, for smart cities, waste management, agricultural stationary asset monitoring, and environmental sensor and data collection. They require very long battery life of 10 to 15 years, extended coverage, latency of 10 to 60 seconds, and low mobility support. Many of these devices are semi-permanent, which are deployed in bridges, buildings, and infrastructures for monitoring purposes, and expected to work for more than a 10 years. Regular replacement of batteries is infeasible.

**Type 4** is usually main powered, such as smart city lighting, home appliances and vending machines which are stationary. Low mobility support, indoor and outdoor coverage, and latency of less than 30 seconds are required. For vending machines latency of about 1 second is required.

Type 1, 2 and 3 are battery powered and require the battery life-time of 5 to 15 years. In Type 1 applications, the battery can be easily recharged, but for other types battery replacement/maintenance is an issue. 3GPP has also identified five challenges for the vast deployment of IoT services: 1) *device cost*, 2) *battery life*, 3) *coverage*,

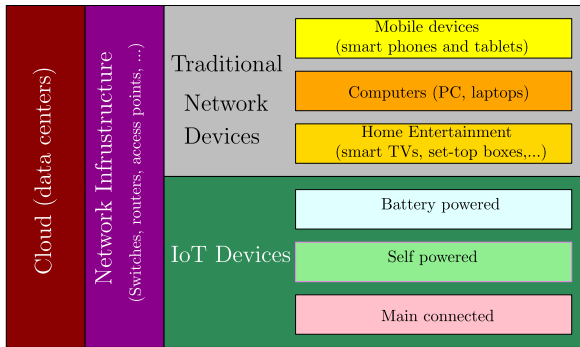

FIGURE 2. Energy consumers in the IoT ecosystem.

4) *scalability*, and 5) *diversity* [17]. Most of IoT devices need small-sized and high-energy density batteries for longer lifetime. This calls for major technological improvements in battery development. Energy harvesting (EH) techniques are interesting alternatives to batteries, which promise to enable autonomous and deployable IoT applications, in energy-rich environments [18]. Extracting energy from the environment, enables the devices to reincarnate once they have accumulated enough energy from the ambience. Energy harvesting is then become an excellent choice for applications, which require increased lifetime, battery-less functionality and ease of maintenance [19].

### III. ENERGY IN THE IOT ECOSYSTEM

IoT consists of several layers of devices, ranging from tiny devices to giant data centres. Fig. 2 shows some of energy consumers in the IoT ecosystem. In the large scale, there are data centres and network infrastructure, which consume huge amount of energy; expecting to dramatically increase in near future. In the small scale, there are traditional network devices, such as mobile phones and tablets, computers and home entertainment, and IoT specific devices, which are somehow new to the market and are expected to grow exponentially in terms of the numbers. Only a small fraction of these devices are powered by connecting to the main power, and most of them would be battery operated or self-powered and use energy harvesting technologies. These were enabled through technological advancements in miniaturization of electronic devices, low power processing, low power wireless communications, and battery and energy storage, and the continuing fall in their prices and sizes. In what follows, we explain the unique characteristics of IoT systems, which distinguish them from WSNs, that have opened new challenges to be solved to enable sustainable IoT systems and applications.

#### A. CHARACTERISTICS OF IOT ENERGY SOURCES

##### 1) SCALABILITY

The energy source for IoT devices must be **scalable**. For the vast deployment of IoT services and applications, the devices need to be placed in all kinds of locations to collect data and communicate with the gateways. The devices may be located

in hard-to-reach areas, so they need to work autonomously without human intervention. They also require minimum maintenance; therefore, batteries are not viable solutions.

##### 2) MAINTENANCE-FREE

The energy source for most IoT applications must be **maintenance-free**. IoT use cases usually involve a large number of devices. Connecting these devices through wiring to the main power is not feasible, as it restrict device movements and also increase the total deployment cost. Batteries are not feasible either as regular battery maintenance is impractical due to the large number of devices, the cost associated with batteries and also the enormous scale of maintenance expenses.

##### 3) MOBILITY SUPPORT

Energy sources for many IoT application must **support mobility**. Many IoT devices are mobile, and the constant movement of the devices must be carefully considered when designing the devices and power management systems.

##### 4) LONG LIFE-TIME

Many IoT applications require energy sources that supports **long life-time** with minimal maintenance. In some IoT applications, for example in structural health monitoring, embedded wireless sensors must be deployed inside the buildings, bridges, etc., and they are supposed to work for several decades. In these applications, both the energy storage and wireless connectivity must be optimized in order to maximize the lifetime of the device.

##### 5) FLEXIBILITY

IoT energy sources must be **flexible in size and capacity** due to wide variety of IoT applications and services. For example in health monitoring applications, a tiny device will be implanted inside the human body to sense vital information and send it to a personal device. This requires long-lifetime tiny batteries or energy-harvesting enabled batteries. Many other applications, such as parking meters, may be connected to main power or can benefit from large photovoltaic cells due to their size and locations.

##### 6) LOW-COST

Many IoT applications will require a large number of devices to be installed. These devices, and accordingly their power sources, should be of low cost; otherwise the application will provide low revenue or is very expensive, which limit its popularity.

##### 7) SUSTAINABILITY

IoT will include trillions of devices, in different scales, and all of them consume power, which will affect our environment. IoT power solutions must be sustainable to avoid the depletion of natural resources in order to maintain an ecological balance. This further emphasizes the importance of energy



harvesting power sources for IoT as alternatives to conventional non-environmentally friendly power sources.

### 8) ENVIRONMENT-FRIENDLY

The expansion of IoT services will negatively impact the environment due to a large number of battery discarding, e.g., more than 125,000 tons of batteries are discarded in USA every year. Discarded AA batteries would circle the earth six times which worsen the problem. Addressing this problem is of urgent priority and energy harvesting techniques provide several solutions.

## B. POWERING IOT DEVICES

### 1) MAIN POWER

Devices in IoT, may be connected to a wired power supply. This is more suitable for IoT applications with fixed-location devices, where a constant power supply can be connected to the device through wires or cables. This however makes the devices immobile, which limits its application in massive IoT. Moreover, it is impractical to connect every device to the power supply through wires when the number of devices is very large. This option is only feasible when the number of devices is very small, and due to specific requirements of the devices is the only way to power the devices.

### 2) BATTERY AND SUPER-CAPACITORS

Battery is the most common energy source which has been widely used in our everyday devices. The stored energy in batteries however is limited, therefore the battery-driven systems have a finite lifetime. It is also difficult and costly to regularly maintain and replace batteries especially when the nodes are remotely located or the number of nodes is very large. These are the main problems of battery-driven systems, which limit the use of batteries in some massive IoT applications.

Lithium batteries are the most efficient batteries which have the highest power densities and efficiencies which can provide higher battery lifetime, suitable for some IoT applications. However, massive IoT applications require the devices to be tiny and autonomous, which put strict limitations on the energy storage and power management of IoT devices. These make the batteries not viable solutions for them [19]. Non-rechargeable batteries cannot be solely used for many IoT applications due to ecological implications and the fact that they have only limited storage [19], [20].

Imprint Energy [21] developed 3D printed Zinc rechargeable batteries were developed by for powering IoT devices, which do not require heavy installation and can be formed into any shape; allowing for customized applications. These batteries are slim and flexible and customizations ensures the required capacity and voltage to avoid extra power conditioning [19]. Another solution which has low power density and high energy density is solid-state thin-film batteries suitable for long-term deployment of IoT devices. The flexibility of these batteries and the fact that they can be manufactured in IC packages have made them suitable

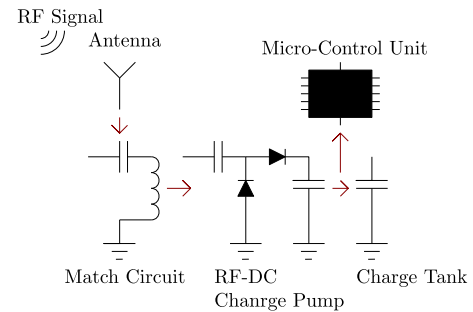

FIGURE 3. RF energy harvesting circuit [23].

candidates for many IoT applications that target low cost and ting device implementation [22]. Super-capacitors have been also considered to replace rechargeable batteries, which have unlimited charge-discharge cycle, but suffer from high self-discharge (up to 20% per day) [19].

Battery storage is a mature technology when compared with energy harvesting technologies, and the fact that batteries are available in different sizes and shapes, make them strong candidate for many massive IoT applications, which are expected to operate with ultra-low power and have limited life time, up to 10 years. Therefore, the battery technology still plays an important role in the IoT ecosystem for many years. The unique requirements of many IoT applications, open new challenges for battery providers.

### 3) RF ENERGY

In RF energy harvesting, the electricity is generated as a result of magnetic inductive coupling effect [24]. It is basically based on the induction of an open circuit voltage around the receive loop from a loop which carries a time varying current. The flux and the open-circuit voltage are mainly determined by the distance between the turns of the loops, the amplitude of the transmit loop current, and the dimension and distance between the loops [24]. The induced voltage at the receive loop can be used to power a passive RFID tag or stored in a rechargeable battery. The voltage induced in the receive loop is approximately 0.5 V [14].

Currently, we use this technology in electronic ID tags and smart cards, which are embedded with passive electronic devices and will be triggered when they are exposed to nearby energy rich sources which are transmitting RF signals. Considering the vast deployment of the devices in massive IoT, this solution may not be scalable as the environment needs to be flooded with RF radiation to power the nodes. Such radiations of RF signals would probably presents health risks for human beings.

Wireless energy harvesting (WEH) has been considered for powering IoT devices in [25] and improvements in terms of being wireless, availability of the RF energy, low cost and relatively easy implementation were shown. Sensor nodes which are powered by WEH usually consist of a transceiver and antenna element (See Fig. 3), a WEH unit which is

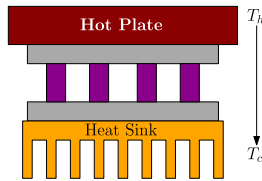

FIGURE 4. Thermal energy generator.

responsible for scavenging RF energy and delivering a stable output power, a power management unit, and possibly an onboard battery. Recently, Freevolt proposed an innovative technology, called Low Energy Internet of Things (LE-IoT) devices, which can harvest RF energy from both short-range and cellular wireless networks, such as 4G, WiFi and Digital TV [26].

Washington University [27] has developed a novel communication system - Wi-Fi Backscatter, which aims to establish Internet connectivity for the IoT RF-powered devices. Nonetheless, the energy harvested from the RF signals is far less comparing with many harvesters that based on other energy sources. Therefore, the scalability of this type of harvesters is limited and these would be more suitable for powering auxiliary devices like Wi-Fi Backscatter.

Another emerging technology that enables the RF energy harvesting is using metamaterials instead of antennas. The concept of metamaterial is to use an architecture consists of many small-sized elements to manipulate the electromagnetic waves. This array of all elements called metamaterial which can be engineered and designed to behave very different compared to other known materials. For instance, a metamaterial can be designed to have a very high absorption coefficient and very low transmission and reflection coefficients. This leads to higher conversion efficiencies for metamaterial energy harvesters. In [28], an RF energy harvester was designed for 900MHz frequency consists of 5 elements reaching the efficiency of 36% at 70Ω load. The unique characteristics of metamaterials made them very attractive for scavenging energy from high frequency electromagnetic waves, optical beams and even acoustic waves [29].

4) THERMAL ENERGY

A thermal energy generator (TEG) (see Fig. 4) converts temperature differences into electrical energy. A TEG usually suffers from low efficiency (5-10%) which limits its widespread adoption [30], [31]. However it has a long life cycle and stationary parts. To extract the energy from a thermal source, a thermal difference is required; e.g, 30 degree difference in the temperature of hot and cold surfaces of the device in the room temperature, results in only up to 10% conversion efficiency [32].

As shown in [33], about 22 μW can be harvested from a human body which was used to derive a Seiko thermic wrist watch and charge a lithium-ion battery. Authors in [30], [34], [35] showed that efficiencies more than 10%

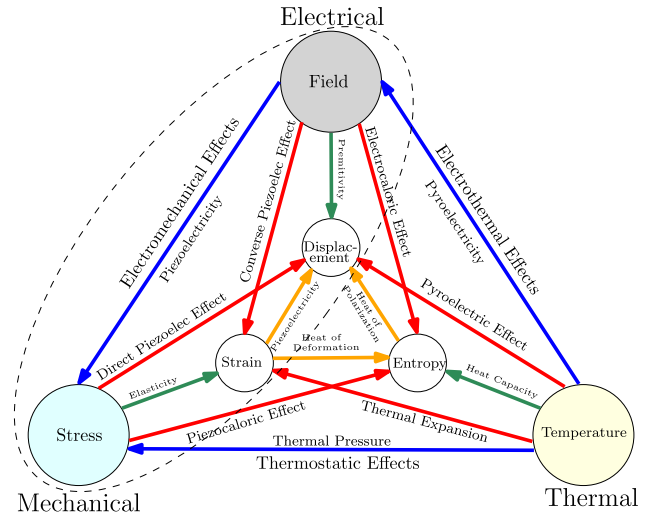

FIGURE 5. A Heckman diagram representing the interrelationship between mechanical, thermal and electrical properties of materials [41].

can be achieved by using new thermoelectric materials and efficient modules. It was also shown that the power density can be scaled by the square of the temperature difference [36], which makes thermal energy harvesting more suitable for environments with large temperature differences, such as buildings with heaters.

5) SOLAR AND PHOTOVOLTAIC ENERGY

Photovoltaic (PV) is considered as one of the most effective EH techniques to power IoT devices due to its power density, efficiency, and the flexibility in terms of different output voltage and current [37], [38]. When sunlight is directed to certain semiconductor materials, solar energy will be converted into DC power. This is called the PV effect. A solar cell is usually composed of silicon and when it is stroke by sunlight with enough energy, the electron and holes are separated and using an input an output regulator, electrons start to move towards the load [39]. To control the charging current to a battery or super-capacitor a maximum power point tracking (MPPT) unit is necessary, which also maximize the efficiency of the PV cells.

Outdoor environments are exposed to sunlight and are generally more appropriate for PV energy harvesting [39], where for a typical outdoor illumination level of 500 W/m<sup>2</sup>, efficiencies of 15% to 25% can be achieved using polycrystalline and amorphous silicon cells [40]. Other indoor environments such as hospitals and stadiums can also benefit from this technology as they have many lightings. Authors in [40] reported PV energy efficiencies of 2% to 10% for indoor applications at illumination level of 10 W/m<sup>2</sup>.

6) MECHANICAL ENERGY

The Heckman diagram shown in Fig. 5 provides an overview of the interactions between mechanical, thermal and electrical properties of solids [41], [42]. A pair of coupled effects is joined by a line, indicating that a small change in one of the variables produces a corresponding change in the other.

Electrical energy can be harvested from vibrations, pressure and stress-strain. Electromagnetic, electrostatic, and piezoelectric are three main mechanisms to generate electricity from mechanical sources [39]. In electromagnetic energy harvesting, the electric current is generated when a magnet moves across a coil. In piezoelectric materials, an electric potential is induced at the terminals of a piezoelectric material due to the polarization of ions in the crystal as a result of the strain. In electrostatic converters, the plates of a charged capacitor are pulled using the vibration, which then results in electrical energy due to the change in the capacitance. Piezoelectric energy harvesters has the highest energy density, that is higher energy can be produced for a given surface area, which is very important in micro scales, where most IoT devices are supposed to operate. Electrostatic mechanism requires separates voltage source and electromagnetic usually generate low voltages.

The harvested energy from vibration increases with the device volume, vibration frequency and the amount of the mechanical force or the amplitude of the vibration. This also relies on the harvesting device mass, which is relative to the vibrating mass [32]. The dominant frequency of vibration relies on the functionality parameters of the apparatus, which causes the vibration. That is the energy production may fall significantly because of the fluctuation in the speed and frequency [32], [43].

The authors in [32] have categorized the mechanical sources into, steady state sources, intermittent sources, human and machine motion, and Gyroscopic motion. The vibration source in steady state mechanical sources are based on the constant flow/motion of a liquid/object in either natural channel or pipes. This energy sources are usually used to generate electrical energy on a macro scale. However, similar concepts can be used to harvest energy on a micro scale, for example using blood flow and inhalation/exhalation in human to harvest energy as reported in [44]. Intermittent mechanical sources on the other hand are not steady and usually require an external object to trigger an event and thus produce the mechanical vibration. For example, the energy can be harvested from human activities such as walking, sitting, and sleeping [32]. Human body is considered as a mechanically-rich environment where different motions and forces can be effectively converted to power wireless devices. A comprehensive summary of the human-based energy harvesting systems was presented in [32].

## 7) HUMAN BODY

Human body is considered as a rich environment to scavenge energy to power wearable electronics [44], [45]. Wearable devices are very important in health monitoring applications, where sensor nodes are deployed on or implanted inside the human body, which form a network called wireless body area network (WBAN). As the battery replacement for wearable devices is inconvenient for people and sometimes impossible in cases when the devices are deployed inside the human

body, the sensor nodes in WBAN must have very long life-time. Therefore, energy harvesting from human body is favorable in these applications [39].

All the aforementioned energy harvesting techniques can be used to harvest energy from the human body. The main challenge is then to miniaturize them for the ease of human adoption [39]. A summary of potential WBAN energy sources was provided in [6]. The human body energy sources can be divided into two main categories: biochemical and biomechanical [6]. Biochemical sources include Glucose [46], Lactate [47], Potential hydrogen [48], and Endocochlear potential [49], and biomechanical sources include heartbeat [50], blood pressure [51], breathing [52], and voluntary locomotion [6]. For example, in [44], [53] the energy was harvested during heel strike and in the bending of the ball of the foot using piezoelectric materials and also in [54], [55] the energy harvested from piezoelectric shoe insert was used to power RFID tags. A summary of different applications and use cases of piezoelectric energy harvesting for wearable bio-sensors was provided in [56].

## C. A BRIEF COMPARISON BETWEEN DIFFERENT ENERGY HARVESTING TECHNIQUES FOR IOT

In Table 2, we have briefly compared different energy harvesting techniques. Energy harvesting from environment is usually uncontrolled and unpredictable and in most cases the conversion efficiency is low. PV cells provides high power density, but they require constant exposure to light which limits their application in many IoT use cases. Temperature based energy harvesting is very limited and can be useful when high temperature difference is guaranteed. RF energy harvesting is also limited due to low efficiency in indoor environment and also in case of multipath. On the other side, mechanical energy harvesting, especially piezoelectric EH can achieve high power densities which is suitable for IoT applications where mechanical vibrations is constantly available.

In Section IV, we will further study vibrational energy harvesting as the promising solutions for massive IoT applications. Piezoelectric materials show high power density and recent technological advancements in developing new materials with enhances electrical properties make them very attractive energy sources for the Internet of things applications in vibration-rich environments.

## D. ENERGY HARVESTING USE CASES IN IOT

EH techniques use different sources of energy in the surrounding environment to harvest enough energy which is used later by the device for sensing, actuating, and communicating with the server. Solar, thermal, vibration, RF signals, and human body are only few examples of the available energy sources in the environment commonly used for energy harvesting, There are several scenarios where EH technologies can significantly enhance the system wide performance, in terms of energy, network life time, cost and maintenance.

**TABLE 2. Energy sources and their energy harvesting potential.**

Energy source & Relevant References	Power density / output power / output voltage	Characteristics	IoT Applications
Solar/PV [37]–[40], [57]	10 $\mu$ W/cm <sup>2</sup> (indoor)-15mW/cm <sup>2</sup> (outdoor) [58] 550mW/3.84V (88 $\times$ 55 $\times$ 2.8mm <sup>3</sup> ) [59] 1300mW/6.5V (111 $\times$ 91 $\times$ 3mm <sup>3</sup> ) [60]	Require exposure to light, low efficiency for indoor devices	<b>Smart Home/Office</b> sensing, e.g., smoke detector, gas sensor, temperature/humidity sensor, fire detection, <b>Smart Factory</b> , e.g., asset tracking using RFID tags, <b>Smart Health</b> , e.g., activity tracker, weight monitoring, smart clothes, dental health, emergency/fall detection, <b>Smart Infrastructure</b> , e.g. smart road light, V2X communication, <b>Smart Logistic/retail</b> , e.g., quality control, tracking, <b>Smart Agriculture</b> , e.g., animal/pest/irrigation monitoring, smart gardening, <b>Smart Environment Monitoring</b> , e.g., water quality/flood monitoring, hazard detection
RF energy [24]–[29], [61]–[66]	0.1 $\mu$ W/cm <sup>2</sup> (GSM) 0.01 $\mu$ W/cm <sup>2</sup> (WiFi) [58] 0.1mW/2.4V (RF-WiFi) [67] 6V (14 $\times$ 13.5 $\times$ 2mm <sup>3</sup> ) [68] 8.9mW (22 $\times$ 19 $\times$ 3mm <sup>3</sup> ) [69]	Low efficiency for indoor and out of line of sight	<b>Smart Factory</b> , e.g., asset tracking using RFID tags, <b>Smart Health</b> , e.g., wearables, nutrition monitoring, <b>Smart Infrastructure</b> , e.g., smart roads, <b>Smart Logistic/Retail</b> , e.g., product tracking, quality monitoring, waste management
Body heat [6], [39], [44], [45]	40 $\mu$ W/cm <sup>2</sup> at 5°C [32] 2.6-5.3V (3 $\times$ 3 $\times$ 1mm <sup>3</sup> ) [70]	Available only for high temperature difference, Easy to build using thermocouple	<b>Smart Health</b> , e.g., wearables, activity tracker, smart body scale, sloop sensor, nutrition monitoring, GPS tracker, long-term body monitoring, emergency/fall detection
External heat [30], [33]–[36], [39], [71]–[75]	135 $\mu$ W/cm <sup>2</sup> at 10°C [32] 5.5mW/2.3-5V (54 $\times$ 38 $\times$ 38mm <sup>3</sup> ) [76]	Available only for high temperature difference, Easy to build using thermocouple	<b>Smart Infrastructure</b> , e.g., smart road, <b>Smart Logistic</b> , e.g., tracking, quality tracking
Body motion [6], [39], [50]–[52], [54], [55], [77]	330 $\mu$ W/cm <sup>3</sup> [32]	Dependent on motion, High power density, not limited on interior and exterior	<b>Smart Health</b> , e.g., wearables, activity tracker, smart body scale, sloop sensor, nutrition monitoring, GPS tracker, long-term body monitoring, emergency/fall detection
Vibration/ Piezoelectric [32], [43], [44], [56], [78]–[83]	4 $\mu$ W/cm <sup>3</sup> [32] 0.8mW/1.8-3.6V (54.4 $\times$ 22.4 $\times$ 0.25mm <sup>3</sup> ) [84]	Has to exist at surrounding, High power density, not limited on interior and exterior	<b>Smart Home/Office</b> , e.g., smart light switches, intrusion detection, <b>Smart Health</b> , e.g., activity tracker, smart body scale, sleep monitoring, smart clothes, pacemaker, electrical toothbrush, emergency/fall detection, <b>Smart Infrastructure</b> , e.g., road pricing, smart roads, V2X communications, <b>Smart Logistic/Retail</b> , e.g., asset tracking, quality tracking, fleet management, <b>Smart Agriculture</b> , e.g., animal/pest/irrigation monitoring, smart gardening, <b>Smart Environment Monitoring</b> , e.g., water quality/flood monitoring, fire detection, hazard detection

We divide these scenarios into three categories as detailed below.

First, energy harvesting is mostly useful in applications where devices are deployed in hard-to-reach areas, therefore, replacing the batteries for sensor nodes is almost impossible [86]. Wireless sensor networks (WSNs) have been widely studied for structural health monitoring, where the damage in aerospace [87], buildings [88], bridges [89], and mechanical infrastructures is detected by sensor nodes. The goal is to replace qualitative visual inspection and time-based maintenance procedures with a more autonomous condition-based damage assessment processes [90]. The aircraft health monitoring system using WSNs and energy harvesting techniques, including thermoelectric and vibration sources, was studied in [91]. Energy harvesting using piezoelectric and inductive devices was also proposed to monitor the health of a real railroad track in [92]. Another example where energy harvesting is crucial is body sensor networks, where the sensors are required to harvest energy for autonomous operation [93]–[96].

Second, energy harvesting can be used in applications which usually require too many devices and replacing their batteries is almost impossible or cost ineffective.

Examples include electronic shelf labeling [97], body sensor networks, and massive IoT applications.

Third, in many applications there is no steady supply of electricity available. An example was discussed in [98], where energy harvesting was used in an agricultural setting to enable a delay tolerant wireless sensor network.

In many IoT applications, such as smart home or smart offices, intelligence transportation systems, smart grids, and industrial monitoring, a large number of devices will be installed everywhere, sometimes in hard-to-reach areas. These devices will be the major consumer of energy in near future due to the rapid growth of their numbers, and the use of energy harvesting will decrease our dependencies on fossil fuels and other traditional energy sources which are depleting very fast. Energy harvesting can also promote environment-friendly, clean technology that saves energy and reduces CO<sub>2</sub> emissions, which is a promising solution for achieving the next generation smart city and sustainable society [86].

On the other hand, energy harvesting could save lots of energy in a wider scope, as it could hugely reduce the cost of modifications in the buildings and industries for wiring and



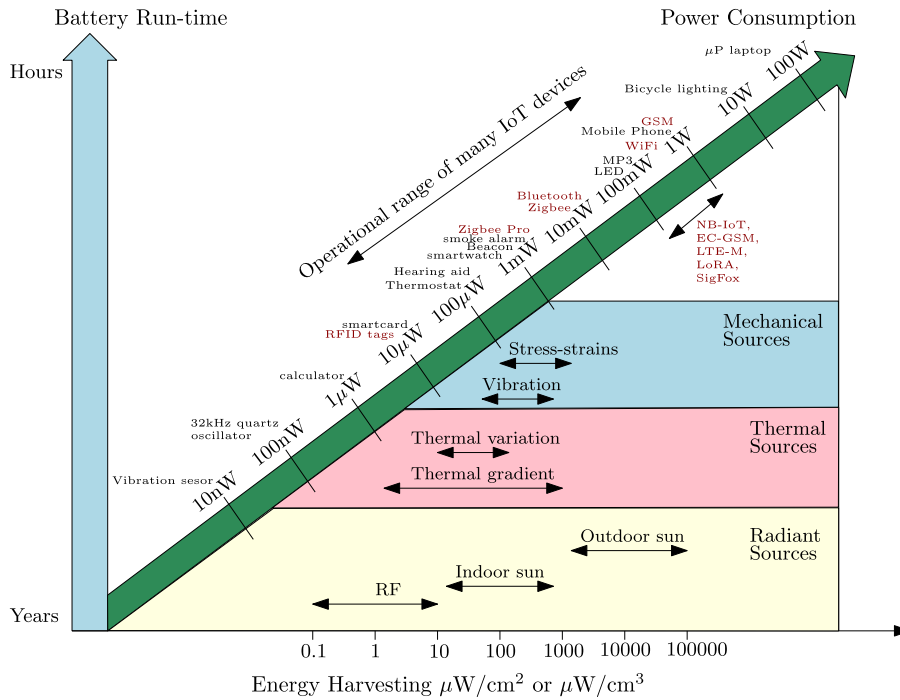

**FIGURE 6.** Power consumption for various applications and power densities for various energy sources (data obtained from [85]).

maintenances. Energy rich environment, such as industries and vehicles, must be capitalized on this available energy, where the small amounts of energy from the environment would be sufficient to run sensor nodes. Advanced sensing techniques in industries will significantly increase the performance and competitiveness, as constant monitoring through embedded devices reduces the cost and energy consumption associated with system failure and maintenance [99]. This however cannot be achieved if the system requires cables or if the battery have to be regularly replaced [100], [101]. Wireless solutions and energy harvesting techniques provide a wide range of solutions for the sensors to become maintenance free. Some examples are the use of piezoelectric energy harvesters for vibration monitoring [102], solar energy harvesting for autonomous field sensors [103], and recently proposed multi-source energy harvester strategies for wireless sensor networks [104].

Fig. 6 shows power requirements of different applications and the power densities for various energy sources. As can be seen selecting the energy source for IoT applications, depends mainly on the application and the specific requirements of that. Silicon Lab [105] has recently identified 5 fundamental considerations for powering wireless IoT sensor products. These include, 1) the target market and its specific requirements on cost, reliability, and network lifetime, 2) energy efficiency and the choice of wireless connectivity, 3) the required transmission strength, duration and duty-cycle between active and sleep states, 4) the sensor node and its power requirement and cost, and 5) the space constraints and storage energy.

#### IV. PIEZOELECTRIC ENERGY HARVESTING

Piezoelectric energy harvesters provide the consistent source of energy and the potential of generating electricity from piezoelectric energy harvesters is higher than alternative energy harvesting technologies. In this section, we study piezoelectric phenomena to be able to compare existing piezoelectric materials in the market. Piezoelectric materials can be optimized based on the intended application, to deliver the required level of voltage or current, and can be manufactured in any shape or size.

##### A. THE PIEZOELECTRIC PHENOMENA

In 1880, Pierre and Jacques Curie measured surface charges that appeared on crystals of tourmaline, quartz, topaz, cane sugar and Rochelle salt when they were subjected to an external mechanical stress, which is called the direct piezoelectric effect. In 1882, the inverse piezoelectric effect was confirmed by Jacques Curie, where the strain  $S$  was observed in response to an applied electric field of strength  $E$ . Fig. 7 shows direct and reverse piezoelectric effects. Piezoelectric materials show a small dimensional changes when exposed to an electric field, while some materials exhibit a reverse behaviour such that an electric polarization occurred when they are mechanically strained.

Direct piezoelectric effect is being considered as the main approach for harvesting energy from vibrations, where the external vibrations causes electrical charge on the terminal of the piezoelectric material [106]. The *monocrystal* and *polycrystalline* structure of same materials can be used to explain the piezoelectricity concept. As shown in Fig. 8-a

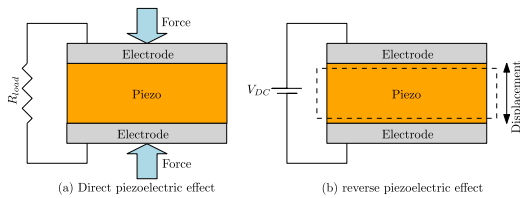

FIGURE 7. Direct and reverse piezoelectric effects.

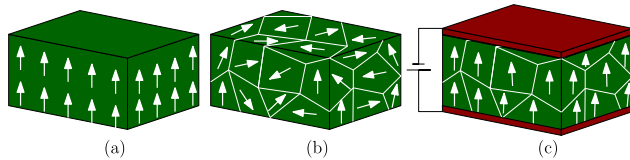

FIGURE 8. Different polarization in crystals. (a) Monocrystal, (b) Polycrystal, and (c) Polarization.

the polar axes of all carriers are aligned in the same direction in a monocrystal. In polycrystal (Fig. 8-b) however, different regions within the material have different polar axes. The piezoelectric effect can be obtained by heating the polycrystal to the Curie point and then applying at a same time a strong electric field. The molecules can then move freely due to the heat which results in the re-arrangement of the dipoles due to the external field (Fig. 8-c). When the material is compressed, a voltage will appear between electrodes. The opposite polarity appears when the material is stretched (i.e., direct piezoelectric effect). On the other hand, when a voltage difference is applied the material will be deformed, and the material will vibrate when an AC signal is applied [107].

There are several figure of merit (FoM) for piezoelectric energy harvesting, but we only discuss about the power density which is more relevant to our topic. The power density, which is defined as the ratio of generated power over the active material volume or over the active material area. As shown in [56], the output power of a piezoelectric generator is proportional to the proof mass, the square of the acceleration magnitude of the driving vibrations, and inversely related to the frequency. As mentioned in [56], piezoelectric devices provide high voltages and low currents. However, using multiple layers of biomorphs, it is easy to design a system that produces voltages and currents in an appropriate range.

**B. ADVANCEMENTS IN PIEZOELECTRIC FABRICATION FOR ENERGY HARVESTING**

Various materials have been previously shown to demonstrate piezoelectric effect and used in several applications such as actuators, sensors, nanogenerators, atomic force microscopes (AFM), high voltage application, energy-harvesting devices, and medical applications. All of these technologies mainly rely on the mechanical energy harvesting [42]. A wide range of both natural and synthetic materials exhibit piezoelectricity. More than 200 piezoelectric materials are available now, where for each energy harvesting application a specific

type can be used. Many biological tissues such as bone, intestine and tendon exhibit piezoelectricity. Some naturally occurring crystals, such as quartz, rochelle salt, cane sugar, topaz, sucrose are classified as natural piezoelectric materials. Lead zirconate titanate (PZT), zinc oxide (ZnO), barium tintonate (BaTiO3), gallium orthophosphate(GaPO4), potassium niobate (KNbO3), lead titanate (PbTiO3), Lithiul tantalate (LiTaO3), langasite (La3Ga5SiO14), sodium tungstate (Na2WO3) and PVDF are the main synthetic piezoelectric materials, which have been widely used.

A wide range of nanogenerators with different structural and functional properties has been developed to provide the optimum mechanical-to-electrical energy conversion by focusing on two main properties: piezoelectricity and triboelectricity [127]. Several inorganic materials in forms of nanorods and nanowires have been used for energy harvesting purposes (e.g nano PZT on PDMS polymer [128], ZnO [129]–[132]), GaN [133], CdS [134], and ZnS [135]). The main challenge in the use of inorganic ceramic piezoelectric are the brittleness and low formability compared to other materials. On the other hand, polymeric based nanogenerators exhibit outstanding processability, ease of fabrication and excellent formability, which make them ideal choices for energy harvesting applications [136]–[139]. The PVDF and its copolymers are the most attractive semi-crystalline polymers being used for piezoelectrical purposes. PVD based films demonstrate ferroelectric, piezoelectric and pyroelectric properties after poling [140], [141].

Compared to crystals, PVDF piezo films offer wider frequency range, sensitivity and mechanical toughness. PZT is suitable for low-noise application, while PVDF is most suited to the high frequency and large bandwidth applications. In addition to this, due to structural and physical property and lower density of the PVDF (1800gr/cm<sup>3</sup> compared to 7600gr/cm<sup>3</sup> for PZT) compared to PZT, PVDF is a preferred candidate for lightweight sensors with curved surfaces and tiny complex structure [142], [143]. Table 3 shows the comparison of piezoelectricity performance of ceramic and polymeric materials at different conditions. Copolymers of PVDF, such as P(VDF-TrFE), are also used in piezoelectric applications, which are available at different PVDF/TrFE molar ratios that significantly improve the crystallinity of the material and piezoelectrical performance, while the copolymer are less polar than pure PVDF [144]. Due to excellent pyroelectric/piezoelectric performance of the β phase, various approaches have been applied to increase the content of this phase in the system by mechanical stretching or electrical poling [145]. Recently, several research teams reported the potential of nanomaterials such as graphene oxide(GO), carbon nanotube, cellulose (CNC) for improvement of the electrical output in PVDF based generators [139], [146], where graphene play an important role in inducing the polymorph in PVDF films [147]–[153].

In a research that carried out in [142] to compare the piezoelectricity of the PZT based and PVDF based sensors, the generated electric signals were recorded to analyse the

**TABLE 3. Performance of piezoelectric materials at different geometries and loading conditions.**

Material	Type	Excitation Amplitude ( $g = 9.8\text{ms}^{-2}$ )	Frequency (Hz)	Size ( $\text{mm}^3 \times \text{number}$ )	Mass (g)	RMS Power	Power density ( $\text{mWcm}^{-3}$ )
PMN-PT [108]	Mesoscale	3.2g	102	$25 \times 5 \times 1 \times 2$	4.2	1.85 mW	7.4
PZN-PT [109]	Mesoscale	0.3g	37.5	$10 \times 7.2 \times 0.4$	2.61	0.43 mW	14.93
PZT [110]	Mesoscale	1.48	73	$13 \times 2.5 \times 1 \times 2$	-	$8.7 \mu\text{W}$	0.134
PZT [111]	Mesoscale	3.5g	77.2	$16 \times 3 \times 0.053(0.076)$	0.433	0.979 mW	158
PZT [112]	Mesoscale	0.7g	120.9	$31 \times 13.6 \times 0.22 \times 2$	23	6.64 mW	35.8
PZT-5A [113]	Mesoscale	1.44g	42	$49 \times 24 \times 0.5$	-	2.5 mW	4.25
PZT-5A [114]	Mesoscale	0.255g	109.5	$53 \times 31.7 \times 0.275 \times 2$	-	0.53 mW	0.57
PZT-5A [115]	Mesoscale	0.4g	20.1	$26 \times 6.4 \times 0.5 \times 2$	8	1.08 mW	9.01
PZT-5H [116]	Mesoscale	0.3 g	22.7	$40 \times 15 \times 0.5$	100	15 mW	50
PZT [117]	MEMS scale	2.5g	255.9	$3 \times 1.5 \times 0.005$	$0.873 \times 10^{-3}$	$1.38 \mu\text{W}$	61.3
PZT [118]	MEMS scale	0.75g	183.8	$3.2 \times 0.4 \times 0.001$	-	$0.32 \mu\text{W}$	250
PZT [119]	MEMS scale	0.39g	528	$1 \times 0.8 \times 0.001$	$1.22 \times 10^{-3}$	$1.1 \mu\text{W}$	1375
PZT [120]	MEMS scale	3.0 g	100.8	$11 \times 5 \times 0.057$	0.12	$321 \mu\text{W}$	102.4
PZT [121]	MEMS scale	0.16 g	6	$20 \times 10 \times 0.003 \times 2$	-	$284 \mu\text{W}$	236.7
AlN [122]	MEMS scale	0.816 g	792	$1 \times 0.21 \times 0.002$	$0.26 \times 10^3$	$1.3 \mu\text{W}$	5420
PVDF [123]	Mesoscale	0.5g	30.8	108	0.63	$8.59 \mu\text{W}$	0.079
PVDF [124]	Mesoscale	2g	15	$30 \times 12 \times 0.028$	1.5	$0.7 \mu\text{W}$	0.15
PVDF [125]	MEMS	2g	32	-	-	38.2nW	-
PVDF [126]	Mesoscale	1g	10	$20 \times 20 \times 0.05$	-	-	6

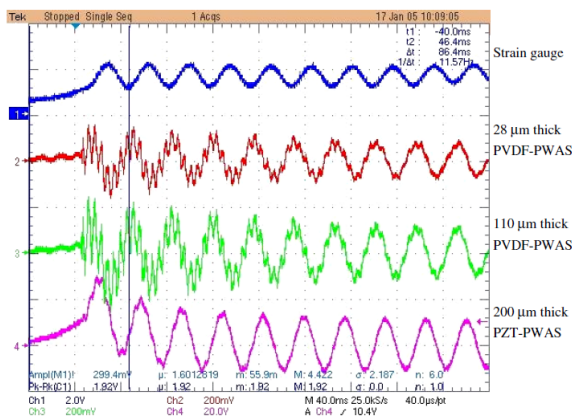
**FIGURE 9. Vibration signal recorded by strain gauge, PVDF-PWAS and PZT-PWAS [142].**

frequency contents of the signals. The signals spectrum are shown in Fig. 9. As can be seen the first three natural frequencies are  $f_1 = 29.7$  Hz,  $f_2 = 181$  Hz, and  $f_3 = 501$  Hz. As can be seen although PZT based sensor deliver higher voltages compared to PVDF based sensors, they are less responsive to the higher frequencies [142].

We have also conducted some research in the area of PVDF based piezoelectric materials. The primary focus has been on investigation of fabrication methods for composite fibres and powder including nanomaterials. This includes fabrication of porous PVDF fiber with high electrical output, fabrication of PVDF/CNT, PVDF/GO and PVDF/CNC fiber (standard and porous structure) and fabrication of electro-sprayed PVDF, PVDF/CNT, PVDF/GO and PVDF/CNC powders with outstanding piezoelectric performance [139].

Low power density of polymer piezoelectric nanogenerators such as PVDF is a major challenge for their application as a potential mode of powering wearable and portable electronic devices. To increase the efficiency, we suggested use of porous piezoelectric poly (vinylidene fluoride-co-trifluoroethylene) (P(VDF-TrFE)) nanofibers instead of pure

PVDF [126]. As shown in [126], the P(VDF-TrFE) can generate relatively large voltages (up to 25 volts). It can be concluded that for development of more effective nanogenerator for energy harvesting from piezoelectric materials, there is a need to optimum output performance to achieve higher energy efficiency. Also beside the energy efficiency, flexibility, formability, corrosion/wear/fatigue resistance need to be considered in fabrication of flexible nanogenerators. Finally, it can be noticed that due to potential of application of piezoelectric nanogenerators for high-tech applications, combinability of as-fabricated piezoelectric materials in fiber and powder form open new windows to overcome challenging issues in applying non-flexible materials in this field [127].

### C. DESIGN CONSIDERATIONS FOR PIEZOELECTRIC-BASED EH-ENABLED IOT DEVICES

A typical EH-enabled IoT device consists of an energy harvester, one or more sensing units, a processing unit, a power management unit, energy storage, and a transceiver (see Fig. 10). The energy harvester convert harvested energy into electrical energy which is managed by the power management unit to be stored in the energy storage. The power management unit will coordinate the power distribution amongst nodes in the IoT device.

Piezoelectric nanogenerators have not been widely used for massive IoT. The main reason is that they can provide electricity when there is enough mechanical vibration in the environment. The generated power is also unpredictable. However, they can be used as a supplementary technology to recharge the battery. The battery will remain the main supplier of energy to the device and the piezoelectric nanogenerator help recharging the battery. This is feasible for many IoT applications that have low data rate demand and perform very limited tasks. These devices can work with a single battery charge for 5-10 years and that is more than enough to harvest energy from the environment to keep charging the battery. The aim is to minimize the battery replacement and maintenance and

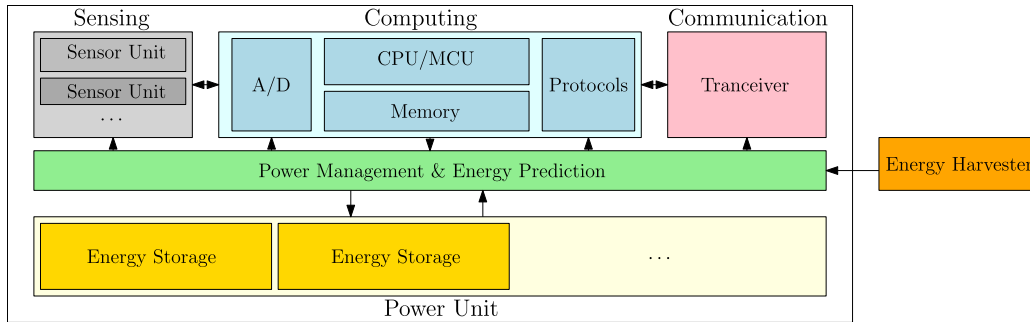

FIGURE 10. A typical EH-enabled wireless IoT device.

piezoelectric nanogenerators are excellent options for this purpose.

In what follows, we focus on the design considerations for piezoelectric energy harvesting IoT devices and provide some useful guidance in this regard. Some detailed design considerations for piezoelectric EH systems have been presented in [56], [154], [155].

#### 1) POWER MANAGEMENT AND ENERGY PREDICTION

Energy harvesting from the environment is unreliable; that is the amount of power which is produced in a particular time instance is random which makes it difficult to continuously deliver sufficient power to the device. Harvesting sources also have low energy potential and low conversion efficiency [156]. Therefore, there should be a power management module that balances the power generation with the power consumption [58]. The knowledge of the existing stored energy and the amount of energy that can be harvested in the future can help significantly improving the energy efficiency and performance. However, accurate energy prediction is very challenging due to the dynamic nature of energy harvesting sources. Authors in [39] categorized energy sources based on their predictability. For example, at stable weather condition one can use an exponential weighted moving average scheme to predict the harvested energy. The algorithm needs data from the same time in the past and might increase the computation load and energy consumption at the sensor node.

Most of these approaches [157]–[160] have been designed for solar energy harvesting, where the prediction can be made using the weather data. Solar energy is the most predictable energy source compared with other sources, including mechanical energy. Accurate prediction for piezoelectric energy harvesting has not been investigated and further research in this area is needed.

In 2010, Sharma *et al.* [161] introduced the notion of *Energy-neutral operation* (ENO), which refers to a state where the energy consumed by the device is always less than or equal to the energy harvested from the environment. Devices operating on the ENO state will potentially have an infinite lifetime [162]. Power management units in EH-enabled IoT devices mainly aim at achieving close to the

ENO state. This mainly depends on the power budget [156], that is what is the required voltage and current for the IoT device? How these requirements are changing in different modes of operation, such as wake up, active, sleep or shut-down? As the largest power in IoT devices used when transitioning from deep sleep to active mode, the duty cycle or the update rate is also a crucial factor for choosing the right technique for powering the device. Minimizing the number of wake-up cycles and transmitting longer data bursts in each cycle is very important to increase the power efficiency [163]. Dynamic power management, energy harvesting aware operation scheduling [164], duty cycling and adaptive sensing [165], cooperative transmission [166], frame length optimization [167], and topology control [168] are amongst several techniques to meet ENO in EH-enabled IoT applications.

#### 2) ENERGY STORAGE

As the current and voltage levels generated from energy harvesting sources system are fairly low, the batteries and super-capacitors must be designed to charge effectively at low power levels. Leakage and internal drain must be minimized too [156]. As shown in [56], the size of the storage capacitor should be at least 100 times the capacitance of the piezoelectric device. There is a tradeoff between the required capacitance for the piezoelectric EH systems and the demand side [56]. Super capacitors are charged quicker than rechargeable batteries, but they will be discharged quicker too due to power leakage [58]. Super capacitors have longer lifetime and better performance in low temperature compared to batteries. On the other hand, batteries are cheaper and have high energy density and lower self-discharge rate. In fact, one needs to take into account the energy requirement of the IoT device and application when designing and choosing the power storage for EH-enabled IoT devices. In many IoT applications, a combination of rechargeable batteries and super-capacitors are used to gain the higher number of charge/discharge cycles of super-capacitors and the high energy density of batteries [169]. For piezoelectric energy harvesting where the output current is usually low, batteries cannot be recharged directly. Super-capacitors then play an important role in storing the very low energy generated by piezoelectric nanogenerators which later recharge the battery.



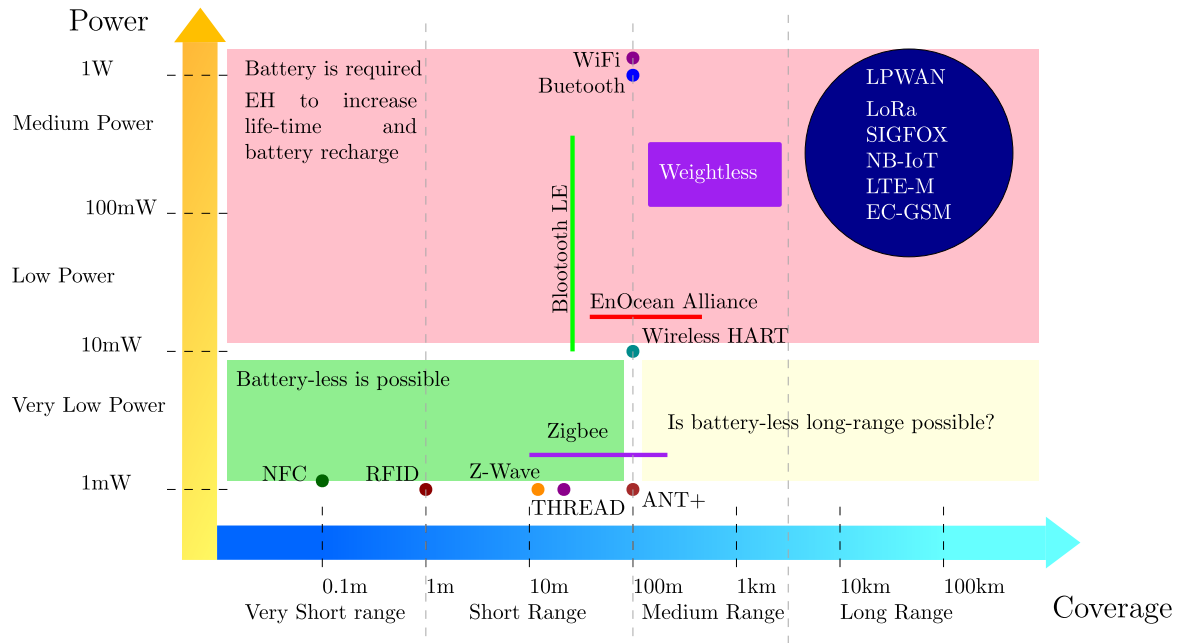

FIGURE 11. Power consumption versus coverage for different wireless technologies.

### 3) OUTPUT POWER

In piezoelectric biomorphs, a dramatic fall in the output power is observed if there is a mismatch between the resonant frequency of the converter and that of the driving vibrations [56]. This has to be carefully considered when designing the IoT energy harvesting unit, so that the designed biomorph resonates at the frequency of the target vibrations. A magnets can be used to limit the vibrations of the device. However this solution is not viable as it adds bulk and cost and limits the broadband ability of the piezoelectric device. Pre-biasing the piezoelectric material is another approach to achieve a power gain up to 20 times. The power output of piezoelectric materials is proportional to the oscillating proof mass. In order to increase the power output, the mass should be maximized by taking into account the space limitations and also the yield strain of the piezoelectric material [56].

The output power of a piezoelectric energy harvester is inversely proportional to the bandwidth. The bandwidth is an important parameter when the piezoelectric harvesters is subject to unpredictable or uncontrollable ambient vibrations. The frequency of ambient vibrations is naturally uncontrollable, therefore narrow-bandwidth energy harvesters are impractical in most real applications. Nonlinear energy harvesters have been shown to extend the working bandwidth for energy harvesters [155]. An electronic control circuit should be accordingly designed to effectively switch between different operating mode to maximize the output power [170].

Several techniques have been proposed to enhance the performance of piezoelectric energy harvesting. These techniques can be categorized from the view point of structure, circuit, and material. Geometry-modified cantilever have

been recently proposed to maximize the output energy, where researchers have changed the regular rectangular shape of the cantilever. Variable width cantilever with fixed length was proposed in [171] to maximize the output power using the same amount of material. Thickness optimization was also considered in [172]. Significant improvement of up to 100% in the output power was reported compared to regular rectangular cantilevers [173].

More general topology optimization to optimize the circuit parameters and layout of the multilayer structure can significantly improve the power output [174], [175]. Curved structure was also proposed to significantly increase the power density (by up to 200%) and energy conversion efficiency (by up to 60%), due to more evenly distributed stress compared to plain plates [176]. Electrode optimization was also proved to be very effective in improving the output power. As shown in [177], the maximum output power can be reached for a piezoelectric harvester when the electrode covers the layer with the maximum strain area.

For many IoT devices, the piezoelectric energy harvester may subject to different kinds of vibrations which leads to low output power. In fact, it cannot be guaranteed that the piezoelectric element is always performing in the optimal operational range. Therefore, the design should be application aware, that is the environment where the device is performing in, should be carefully analysed to understand the different operational mode for the piezo elements.

Moreover, in a standard piezoelectric transducer which converts vibration to electricity, the printed-circuit boards of the electronics is subject to same vibration and can lead to premature failure. To avoid this, an accurate understanding of the generating environment, the power generated, and

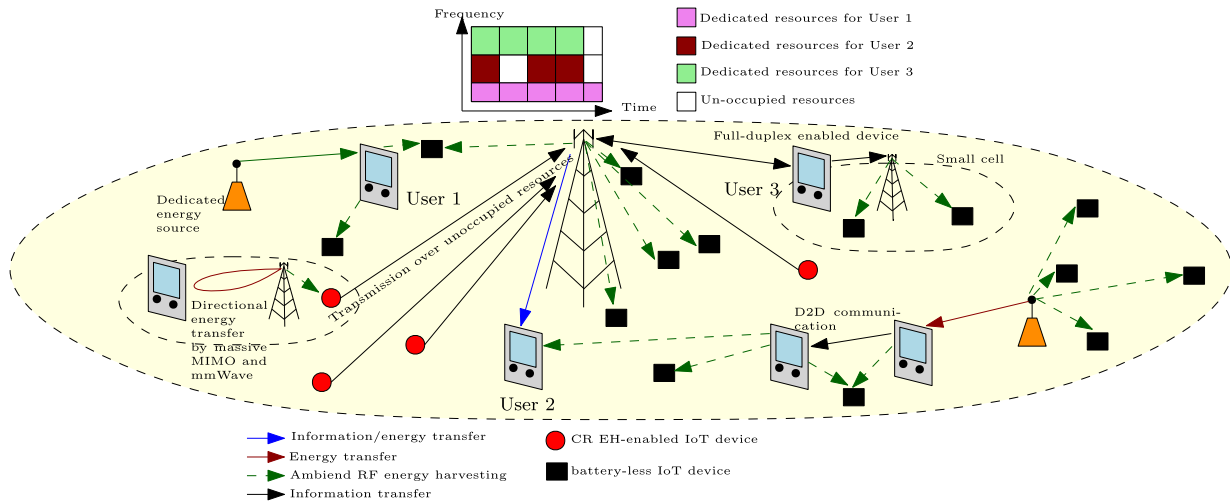

FIGURE 12. Hybrid energy harvesting in heterogeneous cellular networks.

the time required, and the device power consumption and consumption time is required.

4) CHOOSING THE WIRELESS TECHNOLOGY

Machina Research [15] estimated that capillary or short-range wireless technologies will service more than 70% of all IoT devices. Most of these devices will be used in indoor environment and they have limited service demand and security requirements. From the market perspective, consumer electronics and building security and automation are the biggest short-range applications. It was also estimated that by 2025 more than 11% of IoT connections will use LPWAN [15]. Extended coverage GSM (EC-GSM), narrow band IoT (NB-IoT), and LTE for MTC (LTE-M) are three main solutions which have been proposed by 3GPP for massive IoT. These low power technologies were mainly designed to increase the battery life-time and the coverage, suitable for many IoT applications. Low power in this context refers to the ability of the IoT device to work for many years on a single battery charge. Long battery life-time is mainly achieved by defining new control and data channels and new power-saving and duty-cycling functionalities for IoT applications [17].

Fig. 11 shows the power requirement for several wireless technologies and their coverage. While short-range wireless communications operate over very low power which might be suitable for many IoT applications, they might not be feasible for applications that require long coverage. In fact, to have long coverage, the transmit power needs to be increased. Several low-power solutions have been proposed so far, which the transmit power ranges from 0.2 to 1 watt. This is much higher than what many short-range wireless technologies require, which may hamper the success of implementing self-powered LPWAN systems. In fact, due to the large transmit power of most LPWAN technologies, batteries will remain an essential parts of IoT devices operating over LPWANs. Energy harvesting techniques will then play a key role in increasing the

device life-time by providing a sustainable way to recharge the batteries.

V. HYBRID ENERGY HARVESTING IN HETEROGENEOUS IOT NETWORKS

As we discussed through this paper, energy harvesting techniques provide a sustainable way to power IoT devices. However, energy harvesting is not reliable and the device may not be able to store enough energy to power the circuits. One can use several energy harvesting techniques [178] to harvest energy from multiple sources at the same time. While this increases the energy storage efficiency, it potentially increases the complexity as multiple power management units should be installed to maximize the energy conversion for each energy source. Hybrid energy harvesting is an interesting technique especially now because of the advancements in energy harvesting techniques miniaturization of sensors.

In future cellular systems, there would be several layers of nodes, including macro and small base stations (see Fig. 12). While this makes the system more complex it brings many advantages, such as higher throughput and lower latency. In RF-enabled IoT systems this can be a useful feature of wireless networks as different layers are potential sources of RF energy. The design of multiple access and resource allocation in heterogeneous networks is challenging and require major investigation [179]. The problem offers several interesting optimization for power allocation, interference managements, and radio resource allocations. One interesting approach to increase the harvesting efficiency and reduce the interference is to use large antenna arrays and massive MIMO. The RF signal can be directed using large antenna arrays and mmWave to mitigate the path-loss. This is however challenging when the direct line of sight path is not available, therefore advance signal processing techniques and beamforming [180] are required [181]. It also may put extra burden on the receiving node to communicate more with the base station to find the direct path.

Using multiple base stations with multiple antennas can significantly improve the overall system performance as it provides several energy sources for IoT devices. Multiple base stations can send power beacons at the same time, while the others operate over in the data TX/RX phases. Although the resource allocation will be more complex, the harvested energy will increase and the overall system throughput is expected to increase accordingly [182]. This would be a feasible solution in 5G as a large number of small base stations are expected to be deployed by using small-cell technologies. Further study in these areas is essential to fully understand the pros and cons of this approach and unleash the potential of mmWave and massive multiple-input multiple-output (MIMO) in the context of RF-enabled IoT systems [181].

#### A. OPPORTUNISTIC ENERGY HARVESTING USING PIEZOELECTRIC MODULES

In many IoT systems, the devices may be mobile and therefore their channel to the base station is constantly varying. This means that the harvesting node may not harvest enough energy due to the movement and therefore cannot send its data. The problem becomes more challenging when the device carries critical information with a strict latency requirement.

Most studies have focused on designing EH-enabled IoT systems where the devices have no mobility. In such scenarios, the system can be optimized to maximize the energy harvesting efficiency and network throughput. However, when the devices are mobile, an additional factor will play a key role in the overall network performance. This factor is the outage due to insufficient energy at the devices. While this might be temporary, it might change the whole system dynamic that can lead to inefficient radio resource and power usage.

There is still a lack of comprehensive study on the dynamic of the IoT systems with mobile users powered by EH resources. RF-based energy harvesting seems a practical solution in mobile scenarios as the ambient RF energy is available everywhere. However, to maximize the systems performance the beamforming and radio resource allocation should be constantly updated due to changes in the channels. This will add extra communication overhead and accordingly extra energy consumption. Further research in this area is required to better understand the outage performance of RF-based IoT systems and develop novel low-complexity algorithms for dynamic optimization of power and radio resource allocation.

Piezoelectric materials are becoming cheaper nowadays and the fact that they provide a high energy density and can be produced in different shapes make them strong candidates for being used as back-up energy resources for many IoT devices. In particular, when the device is expected to work for a long time and exposed to many vibrations, the device could harvest enough energy using piezoelectric units and store it in the battery. This will significantly increase the device lifetime.

#### B. COGNITIVE-RADIO (CR) BASED IOT USING EH TECHNIQUES

As shown in Fig. 12, many of IoT devices are located in areas that may not receive adequate RF signal to harvest energy. Many of them are subject to movement and therefore can collect enough energy from the environment. Using piezoelectric material, these devices can harvest enough energy and once they collected enough energy they can perform transmission. In fact, dedicated resources cannot be allocated to these devices as their activities is random and depend on their energy profile. Cognitive radio (CR) techniques could potentially solve this problem.

CR technology enables devices to opportunistically access a spectrum primarily assigned to licensed users beforehand. Integrating RF-based energy harvesting with CR technology is of utmost importance which opens up new opportunities. It also creates many challenges which are different from traditional cognitive radio networks (CRNs). In CR networks, a secondary user/device needs to sense the spectrum to find unused spectrum for its own utilization [183] (see Fig. 12). The sensing energy is an important factor that needs to be considered especially for low-power IoT devices which are operating with RF-based energy harvesting. Most existing works have neglected this energy in their proposed frameworks.

Another important aspect is the varying behaviour of the primary user. For example, User 2 in Fig. 12, may request for more data rate, therefore it occupies more radio resources. In this case the CR users (depicted by red circle in Fig. 12) need to wait more for finding unoccupied spectrum. The sensing process however is energy consuming and may deplete the battery very quickly, which might take long time to be recharged again by the ambient RF signal [184]. Secondary user may pose severe interference on the primary users due to the energy transfer phase for secondary users. What is clear though is that the primary users' transmissions is an opportunity for secondary users to harvest energy. However, secondary users' transmissions usually cause interference for primary users. Although several cooperative and non-cooperative strategies have been proposed to minimize the interference, these approaches mostly rely on the assumption that the user activities are known. For these cases and optimal sensing operation and time and power allocation can be derived.

Further research in this area is needed to better understand the dynamic of CR based EH-enabled IoT systems. Dynamic frame structure should be considered for these systems to be able to maximize the spectrum utilization and minimize the energy wastage due to unnecessary spectrum sensing by EH-based IoT devices. Power and radio resource management should be optimized for more practical scenarios where the primary users' behaviour is changing. Statistical information of users activity should be taken into account to minimize the radio resource wastage and unnecessary spectrum sensing.

### C. ENERGY AND RADIO RESOURCE MANAGEMENT

RF energy harvesting has shown to be an effective approach to enable sustainable massive IoT systems. An IoT device may either harvest RF signal energy or decode the information via optimal switching rules [185]. In such strategies, the device first harvest enough energy and then start transmitting/receiving information. This feature is very useful for massive IoT applications with bursty traffic. That is the device only reports the data upon receiving a request from the data centre/gateway. The device switches between two operation modes, namely silent (or energy harvesting mode) and active (or data TX/RX mode). In many massive IoT applications, the device reports very infrequently which leaves enough time for the device to harvest enough energy from ambient RF signals. The harvested energy depend on the received signal strength and the time duration of the harvesting. The transmission range cannot be long as the IoT devices are usually low cost and have limited functionality.

For massive IoT there are two possible solutions to enable RF-based massive IoT systems. The first solution is to use a dedicated RF signal generator to beam the RF signal towards the devices and therefore harvest energy. The other solution is to harvest energy from ambient RF sources, like cellular, TV and WiFi signals. While this increase the system complexity as the RF harvesting circuit may need to work over a different spectrum and bandwidth, this solution has recently attracted interests for massive IoT. In fact, the devices harvest energy from ambient signals which are not intended for themselves. This scheme however is only feasible for short-distance and infrequent device-to-device communications.

Optimal strategies should be developed by jointly considering power control and resource allocation. Both systems level and per-user optimization should be considered for different IoT services, including delay sensitive and delay tolerant use cases. Non-orthogonal multiple access (NOMA) can be effectively used to improve the spectrum efficiency and reduce the system complexity [17]. More specifically, EH-enabled NOMA strategies should be developed to increase the system capacity while maximizing the energy efficiency.

### D. DEVICE-TO-DEVICE (D2D) COMMUNICATIONS AND ENERGY ECONOMICS

In D2D, devices are allowed to directly communicate with each other. This significantly helps to reduce the transmit power as the device transmits only to nearby devices. In D2D, direct communication with the base station may not be available, therefore relying only on harvesting energy from the signal transmitted by the base station is not feasible.

The same way that D2D communication enables data transfer between nearby devices, energy transfer between the devices should be enabled to create an adaptive and flexible wireless energy charging. This however may not be an option for low power wireless devices usually used in massive IoT scenarios. In particular in RF energy harvesting, the harvested

energy depends on the received signal strength and the nearby devices may not be able to provide the required level of energy. IoT devices can request to harvest energy from more powerful devices nearby, however this requires an agreement between different sectors. In other words, the devices that request for energy from nearby devices need to pay for the service that they receive. it is still a major challenge in communication system especially in massive IoT systems to implement a low-cost and low-complexity transaction mechanisms to enable device to device interaction without the direct involvement of a third party such as the base station. Future research and development in this area are of utmost importance to fully unleash the potential of D2D-based EH enabled IoT systems.

Energy-efficient power control should be developed for D2D communications to enable cognitive radio-based IoT in cellular systems. In [186], a power control mechanism was designed where uplink resource blocks allocated to one cellular user equipment are reused by multiple D2D pairs. Reducing the co-channel interference caused by resource sharing is however a significant challenge. Moreover, more thorough analysis and design should be developed when using EH techniques by taking into account the dynamic of energy harvesting and duty cycling.

### E. DELAY SENSITIVE AND RELIABLE VS. DELAY TOLERANT IOT APPLICATION

In many IoT applications, the devices need to send the message in a timely manner. Examples include tracking applications and health monitoring. For such applications, the device needs to be operated by batteries, so regular transmissions can occur in a timely manner. Piezoelectric modules are therefore necessary to recharge the battery to extend the device lifetime. As the device in transmitting in regular time intervals, the power management unit need to frequently switch between the two states, i.e., storage and usage. The design is therefore challenging in terms of maximizing the storage efficiency in the given time frame in order to minimize the probability of depleting the battery energy. A major issue is that the battery recharging cycle mainly depend on the current state of the battery. That is when the battery level is below 30%, the battery could be recharged very quickly.

It is important to note that when reliability is a concern, for example in mission critical IoT applications, both the power source and the communication technology must be reliable. In these applications, reliable batteries should be used or if possible the device should be connected to the main power. Another option is to regularly change or recharge the battery which indeed increase the cost. While this might not be an issue in small networks, in massive IoT is a challenging problem. In many IoT applications, the device transmit a small packet of data very infrequently. For example in water level monitoring applications, the water level is changing very slowly, therefore the data is updated only a few times a day. Therefore, the energy harvesting unit has enough time



to harvest energy from the piezoelectric unit through the vibration. In such systems, the periodic transmissions should happen such that there is enough energy available for the transmission. One needs to adapt the sensing and transmission mechanisms to the environment conditions so that the energy stored in the given time interval is enough for the sensing and transmission.

In many event-driven IoT applications, the device usually remains in the sleep mode and wakes up only when an event happens. For example, an alarm-based system that monitors the door movement. When the door is opened, the device needs to send an alarm signal to the gateway or central controller. The movement generates enough energy to be converted to electricity by the piezoelectric unit. For such a system, the communication must happen in a timely manner as the device has a limited energy storage and cannot retransmit the message several times. Grant-free access techniques are therefore necessary to minimize the access delay and power inefficiency due to several access requests by the IoT devices.

## VI. SECURITY CHALLENGES OF EH-ENABLED IOT SYSTEMS

There are three main limiting factors which might lead to several potential security risks. These are mainly caused by the environment and impact the EH-enabled IoT devices. First, energy harvesting from the environment is unpredictable; that is the amount of power which is produced in a particular time instance is random, which makes it difficult to continuously deliver sufficient power to the device. Harvesting sources also have low energy potential and low conversion efficiency [156]. Although the power management module and the effective use of battery or super-capacitors can partly solve this problem, this may lead to temporary security risks due to service unavailability.

Second, the physical environment is very important in terms of reliability, possible hazards and incidents. In fact the device and EH circuit must be robust to real-world disruptions [156].

Third, the physical property which is used to harvest energy from, can damage the associated electronics. For example, in a standard piezoelectric transducer which converts vibration to electricity, the printed-circuit boards of the electronics are subject to the same vibration and can lead to premature failure. To avoid this, an accurate understanding of the generating environment, the power generated, and the time required, and the device power consumption and consumption time is required.

These limiting factors are potential sources of threats to the EH-enabled IoT systems. EH-enabled devices are vulnerable to malicious attacks that mainly limit accessing the energy resources. For example, IoT devices that are powered by PV cells may not receive enough sunlight, due to the blockage by a third-party, to perform their operations. Also, the target device might not be easily compromised, but the attackers could easily change other devices' behavior or the

surrounding environment, which have interdependence relationships to achieve their aims [187].

Several papers in literature have studied the vulnerabilities, attacks and information leaks, and the design of security mechanisms to provide security and privacy within the context of users and the devices. For a nice summary of these studies refer to [188]–[193]. These studies are however in their initial stages and lack applicability, and many problems remain open [187]. In particular, there is no unified framework to design a secure wireless system based on EH techniques. When the devices are powered by EH sources, they are faced with an additional threat from the attacker who can change the environment. For example the RF source could be blocked and the devices cannot send their data anymore. In fact, the more the devices are geared with the environment, the more they are vulnerable to the threats.

We conclude here that researchers need to investigate further to discover the new security threats and the root causes and new IoT features enabled by energy harvesting behind them. We need to design more generic and practical protective measures by taking into account the extra vulnerability added by energy harvesting mechanism. Relying only on energy harvesting techniques is a serious risk which should be carefully evaluated before investing in it. If there is no backup system, EH-enabled systems are not suitable for any application that deals with critical information and requires high reliability, availability, and low end-to-end latency.

## VII. ENERGY HARVESTING MARKET PERSPECTIVE

Gartner estimated that the total number of IoT devices will reach 20 billion by 2020 [195]. Only a small fraction of these devices will be our smart phones and computers and a majority of them perform simple tasks such as sensing and transmitting a small amount of data once in a while. Major industries will be equipped with embedded smart sensors to gather data from their machinery to better track inventory and manage machines. This will significantly increase efficiency, revenue, and save costs and even lives. There are about 4.7 million developers in the world who can create IoT devices, and the number is increasing at a rate of around 3% per year [195]. Intel reported that IoT technology will be worth about USD 5.2 trillion globally, where healthcare and manufacturing will share USD 2.5 trillion and USD 2.3 trillion, respectively [196].

The global energy harvesting market reached \$880 million in 2014 and \$1.1 billion in 2015 and will continue to grow to \$4.4 billion by 2021 [197]. Fig. 13 and Fig. 14 show the energy harvesting market in 2011 and 2017, respectively. Consumer electronics cover the maximum share of the global EH market.

As shown in Fig. 13 and Fig. 14, Industrial and WSNs experience the fastest growth amongst energy harvesting sectors [198]. This is due to the vast deployment of miniaturized devices for industrial automation and monitoring, structural health monitoring, environmental monitoring, and home automation. In other words, the wide adoption of energy

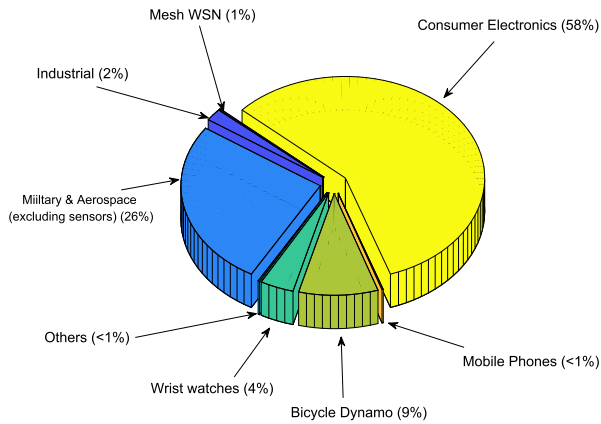

FIGURE 13. Energy harvesting market 2011 [194].

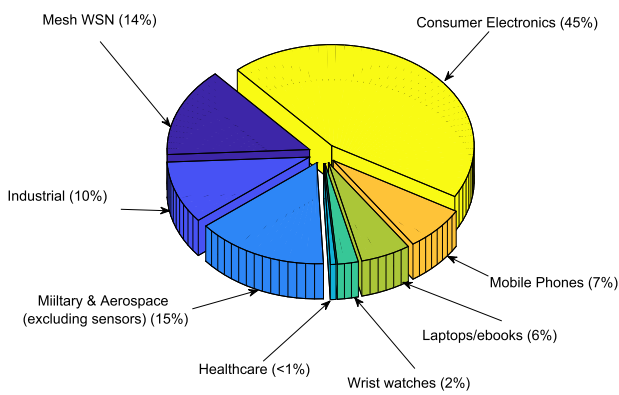

FIGURE 14. Energy harvesting market 2017 [194].

harvesting techniques in IoT applications has increased the share of EH market for IoT related sectors, such as industrial and WSNs. It is also important to note that the share of healthcare in EH market is expected to grow very rapidly due to the popularity of IoT applications in healthcare.

The market for the piezoelectric energy harvesting is expected to grow significantly which is due to the highest reliability, efficiency and power output by size and cost offered by the piezoelectric energy devices harvesters against the other energy harvesting technologies. The market for industrial applications of piezoelectric energy harvesting is growing significantly due to its wide applications in oil and gas manufacturing, and more generally in industrial environments, where piezoelectric energy harvesting offers a cost-effective alternative to expensive wired infrastructure. Asia Pacific and North American countries are expected to show higher growth in the piezoelectric energy harvesting market over the forecast period [199].

The piezoelectric market can be segmented as industrial switches, consumer electronics, aerospace, healthcare, electronic locks, lighters and other electrical, military, pavements, roads, and railroads, push-button industrial sensors, remote controls, toys and gadgets, and vehicle sensors. Due to potential of piezoelectric nanogenerators for high-tech applications, fabrication of hybrid piezoelectric materials in fiber and powder form open new windows to overcome

challenges associate with applying non-flexible materials in this field [127].

One of the main potential use cases of piezoelectric materials is in structural health monitoring. Tiny devices are installed in the structures, such as buildings, bridges, air-planes, and they are expected to continuously work for several years. Powering these devices with batteries is almost impossible as battery replacement is sometime impossible as the devices are out of reach. Battery replacement is not cost-effective and also battery size may be an issue in these applications. Piezoelectric materials provides an unlimited source of energy for these sensors, as structures are rich environments of vibrations. Piezoelectric actuators can be designed in different shapes and sizes; therefore has the potential to lift IoT technologies in structural health monitoring.

Healthcare industry is also considered as one of the main potential targets for piezoelectric materials. Implanted devices can be powered by piezoelectric materials instead of batteries, to increase the lifetime of these devices and make them comfortable for the patients. Wearable sensors, such as smart watches and fitness trackers, can be also powered by piezoelectric materials to convert human body motion into electricity to perform measurements and wireless communication with personal devices.

Some of the key players in the piezoelectric energy harvesting market include Advanced Cerametrics, Boeing, Honeywell, ITT, Microstrain, Inc., Smart Material Corp., and Tokyo Institute of Technology [199]. As reported by IDTechEx, about \$145 million in 2018 will be spent on piezoelectric energy harvesting and by 2022 it will create a market of \$667 million [200]. Energy harvesting provide a sustainable way of powering IoT devices. It however requires different elements like power management units and storage. In comparison with batteries, batteries are smaller and cheaper. The price of energy harvesting solutions is decreasing, and they will continue to evolve at the chip and small device level. While batteries will still play a key role in powering IoT devices, EH techniques will potentially increase the lifetime of IoT devices when a reliable battery and power management unit are installed.

## VIII. CONCLUSION

This paper reviews energy harvesting techniques for Internet of Things (IoT) services and applications. Over 50 billion multi-role devices, capable of sensing and actuating, will be installed by 2025, which shows a tremendous growth in the number of devices and creates new challenges and opportunities. A major burden is powering these devices, as using the main power and batteries is mostly restricted due to the small sizes of many devices and the fact that these devices are installed in hard-to-reach areas, where regular battery maintenance is impractical and very expensive. A viable solution is to use energy harvesting techniques to harvest energy from environment and provide enough energy to the devices to perform their operations. This will significantly increase the

device life time and eliminate the need for the battery as an energy source. Different energy harvesting techniques were presented in this survey and pros and cons of each technique were discussed. As efficient energy harvesting technique, we focused on piezoelectric energy harvesting and radio frequency energy harvesting due. We briefly introduced the main concepts and design challenges for these technologies. As short-range wireless technologies are operating at mW power range, the development of battery-less IoT devices may be feasible. However, due to the large transmit power of most LPWAN technologies, which are expected to play key roles to provide massive IoT services, batteries will remain an essential parts of IoT devices operating over LPWANs. Energy harvesting techniques will then play key roles in increasing the device life-time by providing a sustainable way to recharge the batteries.

## REFERENCES

- [1] CISCO, "The Internet of Things reference model," White Paper," 2014. [Online]. Available: [http://cdn.iotwf.com/resources/71/IoT\\_Reference\\_Model\\_White\\_Paper\\_June\\_4\\_2014.pdf](http://cdn.iotwf.com/resources/71/IoT_Reference_Model_White_Paper_June_4_2014.pdf)
- [2] Intel. (2017). *The Internet of Things Starts With Intel Inside*. [Online]. Available: <https://www.intel.com/content/www/us/en/internet-of-things/overview.html?cv=1&session-id=a72c71a6dead059d17510ab183b548c4>
- [3] K. Wang, Y. Wang, Y. Sun, S. Guo, and J. Wu, "Green industrial Internet of Things architecture: An energy-efficient perspective," *IEEE Commun. Mag.*, vol. 54, no. 12, pp. 48–54, Dec. 2016.
- [4] H. Jayakumar, K. Lee, W. S. Lee, A. Raha, Y. Kim, and V. Raghunathan, "Powering the Internet of Things," in *Proc. Int. Symp. Low Power Electron. Design*, Aug. 2014, pp. 375–380.
- [5] F. Akhtar and M. H. Rehmani, "Energy replenishment using renewable and traditional energy resources for sustainable wireless sensor networks: A review," *Renew. Sustain. Energy Rev.*, vol. 45, pp. 769–784, May 2014. [Online]. Available: <http://www.sciencedirect.com/science/article/pii/S1364032115001094>
- [6] F. Akhtar and M. H. Rehmani, "Energy harvesting for self-sustainable wireless body area networks," *IT Prof.*, vol. 19, no. 2, pp. 32–40, Mar./Apr. 2017.
- [7] S. Chalasani and J. M. Conrad, "A survey of energy harvesting sources for embedded systems," in *Proc. IEEE SoutheastCon*, Apr. 2008, pp. 442–447.
- [8] Y. Faruk "Potential ambient energy-harvesting sources and techniques," *J. Technol. Stud.*, vol. 35, no. 1, pp. 40–48, 2009.
- [9] M. Zareei, C. Vargas-Rosales, R. Villalpando-Hernandez, L. Azpilicueta, M. H. Anisi, and M. H. Rehmani, "The effects of an adaptive and distributed transmission power control on the performance of energy harvesting sensor networks," *Comput. Netw.*, vol. 137, pp. 69–82, Jun. 2018. [Online]. Available: <http://www.sciencedirect.com/science/article/pii/S1389128618301300>
- [10] V. Raghunathan and P. H. Chou, "Design and power management of energy harvesting embedded systems," in *Proc. ACM Int. Symp. Low Power Electron. Design*, Oct. 2006, pp. 369–374.
- [11] D. Pimentel and P. Musflele, "Power management with energy harvesting devices," in *Proc. 23rd IEEE Can. Conf. Elect. Comput. Eng. (CCECE)*, May 2010, pp. 1–4.
- [12] W. K. G. Seah, Z. A. Eu, and H.-P. Tan, "Wireless sensor networks powered by ambient energy harvesting (WSN-HEAP)—Survey and challenges," in *Proc. 1st IEEE Int. Conf. Wireless Commun., Veh. Technol., Inf. Theory Aerosp. Electron. Syst. Technol.*, May 2009, pp. 1–5.
- [13] X. Ju, W. Liu, C. Zhang, A. Liu, T. Wang, N. N. Xiong, and Z. Cai, "An energy conserving and transmission radius adaptive scheme to optimize performance of energy harvesting sensor networks," *Sensors*, vol. 18, no. 9, p. 2885, 2018. [Online]. Available: <http://www.mdpi.com/1424-8220/18/9/2885>
- [14] S. Sudevalayam and P. Kulkarni, "Energy harvesting sensor nodes: Survey and implications," *IEEE Commun. Surveys Tuts.*, vol. 13, no. 3, pp. 443–461, Sep. 2011.
- [15] MachinaResearch. (2016). *Press Release: Global Internet of Things Market to Grow to 27 Billion Devices, Generating USD3 Trillion Revenue in 2025*. [Online]. Available: <https://machinaresearch.com/news/press-release-global-internet-of-things-market-to-grow-to-27-billion-devices-generating-usd3-trillion-revenue-in-2025/>
- [16] GSMA. (2016). *3GPP Low Power Wide Area Technologies White Paper*. [Online]. Available: <https://www.gsma.com/iot/wp-content/uploads/2016/10/3GPP-Low-Power-Wide-Area-Technologies-GSMA-White-Paper.pdf>
- [17] M. Shirvanimoghaddam, M. Dohler, and S. J. Johnson, "Massive non-orthogonal multiple access for cellular IoT: Potentials and limitations," *IEEE Commun. Mag.*, vol. 55, no. 9, pp. 55–61, Sep. 2017.
- [18] R. V. Prasad, S. Devasenapathy, V. S. Rao, and J. Vazifehdan, "Reincarnation in the ambiance: Devices and networks with energy harvesting," *IEEE Commun. Surveys Tuts.*, vol. 16, no. 1, pp. 195–213, 1st Quart., 2013.
- [19] A. Somov and R. Giaffreda. (2015). *Powering IoT Devices: Technologies and Opportunities*. [Online]. Available: <http://iot.ieee.org/newsletter/november-2015/powering-iot-devices-technologies-and-opportunities.html>
- [20] Element14 Community. (2015) *Why the Internet of Things Needs Energy Harvesting*. [Online]. Available: <https://www.element14.com/community/groups/internet-of-things/blog/2015/07/28/how-energy-harvesting-can-keep-the-iot-powered-up-and-growing>
- [21] Imprint Energy. (2016). *Transforming the Battery Landscape*. [Online]. Available: <http://www.imprintenergy.com/>
- [22] Cymbet. (2015). *Enerchip Smart Solid State Batteries*. [Online]. Available: <http://www.cymbet.com/products/enerchip-solid-state-batteries.php>
- [23] R. J. Vyas, B. B. Cook, Y. Kawahara, and M. M. Tentzeris, "E-WEHP: A batteryless embedded sensor-platform wirelessly powered from ambient digital-TV signals," *IEEE Trans. Microw. Theory Techn.*, vol. 61, no. 6, pp. 2491–2505, Jun. 2013.
- [24] M. Safak, "Wireless sensor and communication nodes with energy harvesting," *J. Commun., Navigat., Sens. Services*, vol. 1, no. 1, pp. 47–66, 2014.
- [25] P. Kamalinejad, C. Mahapatra, Z. Sheng, S. Mirabbasi, V. C. M. Leung, and Y. L. Guan, "Wireless energy harvesting for the Internet of Things," *IEEE Commun. Mag.*, vol. 53, no. 6, pp. 102–108, Jun. 2015.
- [26] Drayson Technologies. (2016). *RF Energy Harvesting for the Low Energy Internet of Things*. [Online]. Available: <http://www.getfreevolt.com/>
- [27] B. Kellogg, A. Parks, S. Gollakota, J. R. Smith, and D. Wetherall, "Wi-Fi backscatter: Internet connectivity for RF-powered devices," *SIGCOMM Comput. Commun. Rev.*, vol. 44, no. 4, pp. 607–618, 2014.
- [28] A. M. Hawkes, A. R. Katko, and S. A. Cummer, "A microwave metamaterial with integrated power harvesting functionality," *Appl. Phys. Lett.*, vol. 103, no. 16, 2013, Art. no. 163901.
- [29] S. Qi, M. Oudich, Y. Li, and B. Assouar, "Acoustic energy harvesting based on a planar acoustic metamaterial," *Appl. Phys. Lett.*, vol. 108, no. 26, 2016, Art. no. 263501.
- [30] J. Tervo, A. Manninen, R. Ilola, and H. Hänninen, "State-of-the-art of thermoelectric materials processing," VTT Tech. Res. Centre Finland, Espoo, Finland, Tech. Rep., 2009, pp. 6–7.
- [31] Y. Zhao, J. S. Dyck, B. M. Hernandez, and C. Burda, "Enhancing thermoelectric performance of ternary nanocrystals through adjusting carrier concentration," *J. Amer. Chem. Soc.*, vol. 132, no. 14, pp. 4982–4983, 2010.
- [32] A. S. M. Z. Kausar, A. W. Reza, M. U. Saleh, and H. Ramiah, "Energizing wireless sensor networks by energy harvesting systems: Scopes, challenges and approaches," *Renew. Sustain. Energy Rev.*, vol. 38, pp. 973–989, Oct. 2014.
- [33] X. Lu and S.-H. Yang, "Thermal energy harvesting for WSNs," in *Proc. IEEE Int. Conf. Syst., Man Cybern.*, Oct. 2010, pp. 3045–3052.
- [34] Z.-G. Chen, G. Han, L. Yang, L. Cheng, and J. Zou, "Nanostructured thermoelectric materials: Current research and future challenge," *Prog. Natural Sci., Mater. Int.*, vol. 22, no. 6, pp. 535–549, 2012.
- [35] N. Satyala, P. Norouzzadeh, and D. Vashae, "Nano bulk thermoelectrics: Concepts, techniques, and modeling," in *Nanoscale Thermoelectrics*. Cham, Switzerland: Springer, 2014, pp. 141–183.
- [36] D. Madan, A. Chen, P. K. Wright, and J. W. Evans, "Printed se-doped MA n-type Bi<sub>2</sub>Te<sub>3</sub> thick-film thermoelectric generators," *J. Electron. Mater.*, vol. 41, no. 6, pp. 1481–1486, Jun. 2012. doi: 10.1007/s11664-011-1885-5.



- [37] Y. Wang, Y. Liu, C. Wang, Z. Li, X. Sheng, H. G. Lee, N. Chang, and H. Yang, "Storage-less and converter-less photovoltaic energy harvesting with maximum power point tracking for Internet of Things," *IEEE Trans. Comput.-Aided Des. Integr. Circuits Syst.*, vol. 35, no. 2, pp. 173–186, Feb. 2016.
- [38] M. Raju and M. Grazier. (2012). *ULP Meets Energy Harvesting*. [Online]. Available: [http://www.extensionmedia.com/basecamp/54722/ecatlowpowermarch2011/ULP\\_MEETS\\_ENERGY\\_TI\\_v1.pdf](http://www.extensionmedia.com/basecamp/54722/ecatlowpowermarch2011/ULP_MEETS_ENERGY_TI_v1.pdf)
- [39] F. K. Shaikh and S. Zeadally, "Energy harvesting in wireless sensor networks: A comprehensive review," *Renew. Sustain. Energy Rev.*, vol. 55, pp. 1041–1054, Mar. 2016.
- [40] C. Ó. Mathúna, T. O'Donnell, R. V. Martínez-Catala, J. Rohan, and B. O'Flynn, "Energy scavenging for long-term deployable wireless sensor networks," *Talanta*, vol. 75, no. 3, pp. 613–623, 2008.
- [41] G. Heckmann, "Die gittertheorie der festen Körper," in *Ergebnisse der Exakten Naturwissenschaften*. Berlin, Germany: Springer, 1925, pp. 100–153.
- [42] M. de Jong, W. Chen, H. Geerlings, M. Asta, and K. A. Persson, "A database to enable discovery and design of piezoelectric materials," *Sci. Data*, vol. 2, Sep. 2015, Art. no. 150053.
- [43] F. M. Discenzo, D. Chung, and K. A. Loparo, "Power scavenging enables maintenance-free wireless sensor nodes," in *Proc. 6th Int. Conf. Complex Syst.*, 2006, pp. 1–8.
- [44] T. Starner, "Human-powered wearable computing," *IBM Syst. J.*, vol. 35, nos. 3–4, pp. 618–629, 1996.
- [45] N. S. Shenck and J. A. Paradiso, "Energy scavenging with shoe-mounted piezoelectrics," *IEEE Micro*, vol. 21, no. 3, pp. 30–42, May/Jun. 2001.
- [46] B. I. Rapoport, J. T. Kedzierski, and R. Sarpeshkar, "A glucose fuel cell for implantable brain-machine interfaces," *PLoS One*, vol. 7, no. 6, 2012, Art. no. e38436.
- [47] W. Jia, G. Valdés-Ramírez, A. J. Bandodkar, J. R. Windmiller, and J. Wang, "Epidermal biofuel cells: Energy harvesting from human perspiration," *Angew. Chem. Int. Ed.*, vol. 52, no. 28, pp. 7233–7236, 2013.
- [48] Z. L. Wang and W. Wu, "Nanotechnology-enabled energy harvesting for self-powered micro-/nanosystems," *Angew. Chem. Int. Ed.*, vol. 51, no. 47, pp. 11700–11721, 2012.
- [49] L. Mateu and F. Moll, "Review of energy harvesting techniques and applications for microelectronics (keynote address)," *Proc. SPIE*, vol. 5837, pp. 359–374, Jun. 2005.
- [50] A. Zurbuchen, A. Pfenniger, A. Stahel, C. T. Stoeck, S. Vandenberghe, V. M. Koch, and R. Vogel, "Energy harvesting from the beating heart by a mass imbalance oscillation generator," *Ann. Biomed. Eng.*, vol. 41, no. 1, pp. 131–141, 2013.
- [51] M. J. Ramsay and W. W. Clark, "Piezoelectric energy harvesting for bio-MEMS applications," *Proc. SPIE*, vol. 4332, pp. 429–439, Jun. 2001.
- [52] C. Dagdeviren, B. D. Yang, Y. Su, P. L. Tran, P. Joe, E. Anderson, J. Xia, V. Doraiswamy, B. Dehdashti, X. Feng, B. Lu, R. Poston, Z. Khalpey, R. Ghaffari, Y. Huang, M. J. Slepian, and J. A. Rogers, "Conformal piezoelectric energy harvesting and storage from motions of the heart, lung, and diaphragm," *Proc. Nat. Acad. Sci. USA*, vol. 111, no. 5, pp. 1927–1932, 2014.
- [53] N. G. Elvin and A. A. Elvin, "Vibrational energy harvesting from human gait," *IEEE/ASME Trans. Mechatronics*, vol. 18, no. 2, pp. 637–644, Apr. 2013.
- [54] P. D. Mitcheson, E. M. Yeatman, G. K. Rao, A. S. Holmes, and T. C. Green, "Energy harvesting from human and machine motion for wireless electronic devices," *Proc. IEEE*, vol. 96, no. 9, pp. 1457–1486, Sep. 2008.
- [55] D. Benasciutti and L. Moro, "Energy harvesting with vibrating shoe-mounted piezoelectric cantilevers," in *Advances in Energy Harvesting Methods*. New York, NY, USA: Springer, 2013, pp. 141–162.
- [56] S. J. Roundy, "Energy scavenging for wireless sensor nodes with a focus on vibration to electricity conversion," Ph.D. dissertation, Dept. Eng.-Mech. Eng., Univ. California, Berkeley, Berkeley, CA, USA, 2003.
- [57] J. Li, A. Liu, G. Shen, L. Li, C. Sun, and F. Zhao, "Retro-VLC: Enabling battery-free duplex visible light communication for mobile and IoT applications," in *Proc. 16th Int. Workshop Mobile Comput. Syst. Appl.*, 2015, pp. 21–26.
- [58] K. S. Adu-Manu, N. Adam, C. Tapparello, H. Ayatollahi, and W. Heinzlman, "Energy-harvesting wireless sensor networks (EH-WSNs): A review," *ACM Trans. Sensor Netw.*, vol. 14, no. 2, Jul. 2018, Art. no. 10. [Online]. Available: <http://doi.acm.org/10.1145/3183338>
- [59] Ningbo Yongjiang Shenzhou Photovoltaic Co., Ltd. (2019). *0.55W/4V Encapsulated Solar Panel*. [Online]. Available: [https://cnszgd.en.ec21.com/0.55W\\_4V\\_Encapsulated\\_Solar\\_Panel-2101891\\_2102227.html](https://cnszgd.en.ec21.com/0.55W_4V_Encapsulated_Solar_Panel-2101891_2102227.html)
- [60] Libelium. (2019). *IoT Made Easy*. [Online]. Available: <http://www.libelium.com/products/plugin-sense/technical-overview/>
- [61] N. Van Huynh, D. T. Hoang, X. Lu, D. Niyato, P. Wang, and D. I. Kim, "Ambient backscatter communications: A contemporary survey," *IEEE Commun. Surveys Tuts.*, vol. 20, no. 4, pp. 2889–2922, 4th Quart., 2018.
- [62] U. Muncuk, K. Alemdar, J. D. Sarode, and K. R. Chowdhury, "Multiband ambient RF energy harvesting circuit design for enabling batteryless sensors and IoT," *IEEE Internet Things J.*, vol. 5, no. 4, pp. 2700–2714, Aug. 2018.
- [63] B. Drozdenko, M. Zimmermann, T. Dao, K. Chowdhury, and M. Leiser, "Hardware-software codesign of wireless transceivers on zynq heterogeneous systems," *IEEE Trans. Emerg. Topics Comput.*, vol. 6, no. 4, pp. 566–578, Oct./Dec. 2018.
- [64] R. G. Cid-Fuentes, M. Y. Naderi, K. R. Chowdhury, A. Cabellos-Aparicio, and E. Alarcoón, "On the scalability of energy in wireless RF powered Internet of Things," *IEEE Commun. Lett.*, vol. 20, no. 12, pp. 2554–2557, Dec. 2016.
- [65] D. Mishra, S. De, S. Jana, S. Basagni, K. Chowdhury, and W. Heinzlman, "Smart RF energy harvesting communications: Challenges and opportunities," *IEEE Commun. Mag.*, vol. 53, no. 4, pp. 70–78, Apr. 2015.
- [66] D. Mishra, S. De, and K. R. Chowdhury, "Charging time characterization for wireless RF energy transfer," *IEEE Trans. Circuits Syst., II, Exp. Briefs*, vol. 62, no. 4, pp. 362–366, Apr. 2015.
- [67] V. Talla, B. Kellogg, B. Ransford, S. Naderiparizi, S. Gollakota, and J. R. Smith, "Powering the next billion devices with Wi-Fi," in *Proc. 11th ACM Conf. Emerg. New. Exp. Technol. (CoNEXT)*, New York, NY, USA, 2015, Art. no. 4. [Online]. Available: <http://doi.acm.org/10.1145/2716281.2836089>
- [68] Powercast. (2019). *915 MHz Rf Powerharvester Receiver*. [Online]. Available: <https://www.powercastco.com/wp-content/uploads/2016/12/P2110B-Datasheet-Rev-3.pdf>
- [69] Powercast. (2019). *Self-Powered Wireless Standard for Smart Buildings*. [Online]. Available: [https://www.enocean.com/en/enocean\\_modules\\_315mhz/stm-300c-user-manual.pdf](https://www.enocean.com/en/enocean_modules_315mhz/stm-300c-user-manual.pdf)
- [70] STMMicroelectronics. (2019). *Ultralow Power Energy Harvester and Battery Charger*. [Online]. Available: <https://www.st.com/resource/en/datasheet/spv1050.pdf>
- [71] V. Leonov, T. Torfs, P. Fiorini, and C. Van Hoof, "Thermoelectric converters of human warmth for self-powered wireless sensor nodes," *IEEE Sensors J.*, vol. 7, no. 5, pp. 650–657, May 2007.
- [72] Z. Wang, V. Leonov, P. Fiorini, and C. van Hoof, "Realization of a wearable miniaturized thermoelectric generator for human body applications," *Sens. Actuators Phys.*, vol. 156, no. 1, pp. 95–102, Nov. 2009.
- [73] A. Cuadras, M. Gasulla, and V. Ferrari, "Thermal energy harvesting through pyroelectricity," *Sens. Actuators A, Phys.*, vol. 158, no. 1, pp. 132–139, Mar. 2010.
- [74] M. Ferrari, V. Ferrari, D. Marioli, and A. Taroni, "Modeling, fabrication and performance measurements of a piezoelectric energy converter for power harvesting in autonomous microsystems," *IEEE Trans. Instrum. Meas.*, vol. 55, no. 6, pp. 2096–2101, Dec. 2006.
- [75] A. Harb, "Energy harvesting: State-of-the-art," *Renew. Energy*, vol. 36, no. 10, pp. 2641–2654, 2011.
- [76] Marlow. (2019). *Thermocyclers*. [Online]. Available: <https://www.marlow.com/products/thermoelectric-coolers/thermocyclers>
- [77] H. Singh and C. M. Lalchand, "Self powered wearable health monitoring system," *Adv. Mater. Res.*, vols. 403–408, pp. 3839–3846, Nov. 2012.
- [78] T. Sterken, P. Fiorini, K. Baert, R. Puers, and G. Borghs, "An electret-based electrostatic  $\mu$ -generator," in *Proc. 12th Int. Conf. Solid-State Sens., Actuators Microsyst. (TRANSDUCERS)*, vol. 2, Jun. 2003, pp. 1291–1294.
- [79] E. Sazonov, H. Li, D. Curry, and P. Pillay, "Self-powered sensors for monitoring of highway bridges," *IEEE Sensors J.*, vol. 9, no. 11, pp. 1422–1429, Nov. 2009.
- [80] J. Kymissis, C. Kendall, J. Paradiso, and N. Gershenfeld, "Parasitic power harvesting in shoes," in *Dig. Papers 2nd Int. Symp. Wearable Comput.*, Oct. 1998, pp. 132–139.
- [81] K.-I. Park, S. Xu, Y. Liu, G.-T. Hwang, S.-J. L. Kang, Z. L. Wang, and K. J. Lee, "Piezoelectric BaTiO<sub>3</sub> thin film nanogenerator on plastic substrates," *Nano Lett.*, vol. 10, no. 12, pp. 4939–4943, 2010.



- [82] J. Kwon, W. Seung, B. K. Sharma, S.-W. Kim, and J.-H. Ahn, "A high performance PZT ribbon-based nanogenerator using graphene transparent electrodes," *Energy Environ. Sci.*, vol. 5, no. 10, pp. 8970–8975, 2012.
- [83] G.-T. Hwang, H. Park, J.-H. Lee, S. Oh, K.-I. Park, M. Byun, H. Park, G. Ahn, C. K. Jeong, K. No, H. Kwon, S.-G. Lee, B. Joung, and K. Jae, "Self-powered cardiac pacemaker enabled by flexible single crystalline PMN-PT piezoelectric energy harvester," *Adv. Mater.*, vol. 26, no. 28, pp. 4880–4887, Jul. 2014.
- [84] Piezo.com. (2019). *QPK-1001*. [Online]. Available: <https://piezo.com/>
- [85] B. Franciscatto, "Design and implementation of a new low-power consumption DSRC transponder," Ph.D. dissertation, Inst. Microelectronique, Université Grenoble Alpes, Grenoble, France, 2014.
- [86] T. Tanaka, T. Suzuki, and K. Kurihara, "Energy harvesting technology for maintenance-free sensors," *Fujitsu Sci. Technol. J.*, vol. 50, pp. 93–100, Jan. 2014.
- [87] T. Becker, M. Kluge, J. Schalk, K. Tiplady, C. Paget, U. Hilleringmann, and T. Otterpohl, "Autonomous sensor nodes for aircraft structural health monitoring," *IEEE Sensors J.*, vol. 9, no. 11, pp. 1589–1595, Nov. 2009.
- [88] T. Torfs, T. Sterken, S. Brebels, J. Santana, R. van den Hoven, V. Spiering, N. Bertsch, D. Trapani, and D. Zonta, "Low power wireless sensor network for building monitoring," *IEEE Sensors J.*, vol. 13, no. 3, pp. 909–915, Mar. 2013.
- [89] M. J. Whelan, M. V. Gangone, and K. D. Janoyan, "Highway bridge assessment using an adaptive real-time wireless sensor network," *IEEE Sensors J.*, vol. 9, no. 11, pp. 1405–1413, Nov. 2009.
- [90] G. Park, T. Rosing, M. D. Todd, C. R. Farrar, and W. Hodgkiss, "Energy harvesting for structural health monitoring sensor networks," *J. Infrastruct. Syst.*, vol. 14, no. 1, pp. 64–79, 2008.
- [91] H. Bai, M. Atiquzzaman, and D. Lilja, "Wireless sensor network for aircraft health monitoring," in *Proc. 1st Int. Conf. Broadband Netw. (BroadNets)*, Oct. 2004, pp. 748–750.
- [92] C. A. Nelson, S. R. Platt, D. Albrecht, V. Kamarajugadda, and M. Fateh, "Power harvesting for railroad track health monitoring using piezoelectric and inductive devices," *Proc. SPIE*, vol. 6928, Apr. 2008, Art. no. 69280R.
- [93] H. Alemdar and C. Ersoy, "Wireless sensor networks for healthcare: A survey," *Comput. Netw.*, vol. 54, no. 15, pp. 2688–2710, Oct. 2010.
- [94] D. Mascareñas, E. Flynn, C. Farrar, G. Park, and M. Todd, "A mobile host approach for wireless powering and interrogation of structural health monitoring sensor networks," *IEEE Sensors J.*, vol. 9, no. 12, pp. 1719–1726, Dec. 2009.
- [95] C. He, A. Arora, M. E. Kiziroglou, D. C. Yates, D. O'Hare, and E. M. Yeatman, "MEMS energy harvesting powered wireless biometric sensor," in *Proc. 6th Int. Workshop Wearable Implant. Body Sensor Netw.*, Jun. 2009, pp. 207–212.
- [96] W. Y. Toh, Y. K. Tan, W. S. Koh, and L. Siek, "Autonomous wearable sensor nodes with flexible energy harvesting," *IEEE Sensors J.*, vol. 14, no. 7, pp. 2299–2306, Jul. 2014.
- [97] P. De Mil, B. Jooris, L. Tytgat, R. Cateeuw, I. Moerman, P. Demeester, and A. Kameran, "Design and implementation of a generic energy-harvesting framework applied to the evaluation of a large-scale electronic shelf-labeling wireless sensor network," *EURASIP J. Wireless Commun. Netw.*, vol. 2010, no. 1, 2010, Art. no. 343690.
- [98] T. V. Prabhakar, S. N. A. U. Nambi, H. S. Jamadagni, K. Swaroop, V. Prasad, and I. Niemegeers, "A novel DTN based energy neutral transfer scheme for energy harvested WSN gateways," *ACM SIGMETRICS Perform. Eval. Rev.*, vol. 38, no. 3, pp. 71–75, 2011.
- [99] M. D. Prieto, D. Z. Millan, W. Wang, A. M. Ortiz, J. A. O. Redondo, and L. R. Martinez, "Self-powered wireless sensor applied to gear diagnosis based on acoustic emission," *IEEE Trans. Instrum. Meas.*, vol. 65, no. 1, pp. 15–24, Jan. 2016.
- [100] B. Aygün and V. C. Gungor, "Wireless sensor networks for structure health monitoring: Recent advances and future research directions," *Sensor Rev.*, vol. 31, no. 3, pp. 261–276, 2011.
- [101] L. Hou and N. W. Bergmann, "Novel industrial wireless sensor networks for machine condition monitoring and fault diagnosis," *IEEE Trans. Instrum. Meas.*, vol. 61, no. 10, pp. 2787–2798, Oct. 2012.
- [102] J. Hu, J. Jong, and C. Zhao, "Vibration energy harvesting based on integrated piezoelectric components operating in different modes," *IEEE Trans. Ultrason., Ferroelectr., Freq. Control*, vol. 57, no. 2, pp. 386–394, Feb. 2010.
- [103] A. Decker, "Solar energy harvesting for autonomous field devices," *IET Wireless Sensor Syst.*, vol. 4, no. 1, pp. 1–8, Mar. 2014.
- [104] A. S. Weddell, M. Magno, G. V. Merrett, D. Brunelli, B. M. Al-Hashimi, and L. Benini, "A survey of multi-source energy harvesting systems," in *Proc. Design, Autom. Test Eur. Conf. Exhib.*, Mar. 2013, pp. 905–908.
- [105] Silicon Labs. (2015). *Battery Size Matters*. [Online]. Available: <https://www.silabs.com/Support%20Documents/TechnicalDocs/battery-life-in-connected-wireless-iot-devices.pdf>
- [106] D. Briand, E. Yeatman, S. Roundy, O. Brand, G. K. Fedder, C. Hierold, J. G. Korvink, and O. Tabata, *Micro Energy Harvesting*. Hoboken, NJ, USA: Wiley, 2015.
- [107] R. Caliò, U. B. Rongala, D. Camboni, M. Milazzo, C. Stefanini, G. De Petris, and C. M. Oddo, "Piezoelectric energy harvesting solutions," *Sensors*, vol. 14, no. 3, pp. 4755–4790, Mar. 2014.
- [108] C. Xu, B. Ren, W. Di, Z. Liang, J. Jiao, L. Li, L. Li, X. Zhao, H. Luo, and D. Wang, "Cantilever driving low frequency piezoelectric energy harvester using single crystal material  $0.71\text{Pb}(\text{Mg}_{1/3}\text{Nb}_{2/3})\text{O}_3-0.29\text{PbTiO}_3$ ," *Appl. Phys. Lett.*, vol. 101, no. 3, 2012, Art. no. 033502.
- [109] Z. Yang and J. Zu, "Comparison of PZN-PT, PMN-PT single crystals and PZT ceramic for vibration energy harvesting," *Energy Convers. Manage.*, vol. 122, pp. 321–329, Aug. 2016.
- [110] J. Zhao, X. Zheng, L. Zhou, Y. Zhang, J. Sun, W. Dong, S. Deng, and S. Peng, "Investigation of a d15 mode PZT-51 piezoelectric energy harvester with a series connection structure," *Smart Mater. Struct.*, vol. 21, no. 10, 2012, Art. no. 105006.
- [111] Z. Yi, B. Yang, G. Li, J. Liu, X. Chen, X. Wang, and C. Yang, "High performance bimorph piezoelectric MEMS harvester via bulk PZT thick films on thin beryllium-bronze substrate," *Appl. Phys. Lett.*, vol. 111, no. 1, 2017, Art. no. 013902.
- [112] L. J. Gong, Q. S. Pan, W. Li, G. Y. Yan, Y. B. Liu, and Z. H. Feng, "Harvesting vibration energy using two modal vibrations of a folded piezoelectric device," *Appl. Phys. Lett.*, vol. 107, no. 3, 2015, Art. no. 033904.
- [113] J. Liang and W.-H. Liao, "Impedance matching for improving piezoelectric energy harvesting systems," *Proc. SPIE*, vol. 7643, Apr. 2010, Art. no. 76430K.
- [114] M. Kim, M. Hoegen, J. Dugundji, and B. L. Wardle, "Modeling and experimental verification of proof mass effects on vibration energy harvester performance," *Smart Mater. Struct.*, vol. 19, no. 4, 2010, Art. no. 045023.
- [115] L. Gu, "Low-frequency piezoelectric energy harvesting prototype suitable for the MEMS implementation," *Microelectron. J.*, vol. 42, no. 2, pp. 277–282, Feb. 2011.
- [116] Z. Yang, J. Zu, J. Luo, and Y. Peng, "Modeling and parametric study of a force-amplified compressive-mode piezoelectric energy harvester," *J. Intell. Mater. Syst. Struct.*, vol. 28, no. 3, pp. 357–366, 2017.
- [117] B. S. Lee, S. C. Lin, W. J. Wu, X. Y. Wang, P. Z. Chang, and C. K. Lee, "Piezoelectric MEMS generators fabricated with an aerosol deposition PZT thin film," *J. Micromech. Microeng.*, vol. 19, no. 6, Jun. 2009, Art. no. 065014.
- [118] D. Shen, J.-H. Park, J. H. Noh, S.-Y. Choe, S.-H. Kim, H. C. Wickle, III, and D.-J. Kim, "Micromachined PZT cantilever based on SOI structure for low frequency vibration energy harvesting," *Sens. Actuators A, Phys.*, vol. 154, no. 1, pp. 103–108, 2009.
- [119] J. C. Park, J. Y. Park, and Y.-P. Lee, "Modeling and characterization of piezoelectric  $d_{33}$ -mode MEMS energy harvester," *J. Micro Electro Mech. Syst.*, vol. 19, no. 5, pp. 1215–1222, Oct. 2010.
- [120] G. Tang, B. Yang, C. Hou, G. Li, J. Liu, X. Chen, and C. Yang, "A piezoelectric micro generator worked at low frequency and high acceleration based on PZT and phosphor bronze bonding," *Sci. Rep.*, vol. 6, Dec. 2016, Art. no. 38798.
- [121] H. G. Yeo, X. Ma, C. Rahn, and S. Trolier-McKinstry, "Efficient piezoelectric energy harvesters utilizing (001) textured bimorph PZT films on flexible metal foils," *Adv. Funct. Mater.*, vol. 26, no. 32, pp. 5940–5946, Jun. 2016.
- [122] L. Van Minh, M. Hara, T. Yokoyama, T. Nishihara, M. Ueda, and H. Kuwano, "Highly piezoelectric MgZr co-doped aluminum nitride-based vibrational energy harvesters [correspondence]," *IEEE Trans. Ultrason., Ferroelectr., Freq. Control*, vol. 62, no. 11, pp. 2005–2008, Nov. 2015.
- [123] R. Sriramdas, S. Chiplunkar, R. M. Cuduvally, and R. Pratap, "Performance enhancement of piezoelectric energy harvesters using multilayer and multistep beam configurations," *IEEE Sensors J.*, vol. 15, no. 6, pp. 3338–3348, Jun. 2015.

- [124] S. Li, A. Crovetto, Z. Peng, A. Zhang, O. Hansen, M. Wang, X. Li, and F. Wang, "Bi-resonant structure with piezoelectric PVDF films for energy harvesting from random vibration sources at low frequency," *Sens. Actuators A, Phys.*, vol. 247, pp. 547–554, Aug. 2016. [Online]. Available: <http://www.sciencedirect.com/science/article/pii/S0924424716303211>
- [125] J. Dayou, J. Kim, J. Im, L. Zhai, A. T. C. How, and W. Y. H. Liew, "The effects of width reduction on the damping of a cantilever beam and its application in increasing the harvesting power of piezoelectric energy harvester," *Smart Mater. Struct.*, vol. 24, no. 4, Feb. 2015, Art. no. 045006. doi: 10.1088/2F0964-1726/2F24/2F4/2F045006.
- [126] M. M. Abolhasani, M. Naebe, K. Shirvanimoghaddam, H. Fashandi, H. Khayyam, M. Joordens, A. Pipertzis, S. Anwar, R. Berger, G. Floudas, J. Michels, and K. Asadi, "Thermodynamic approach to tailor porosity in piezoelectric polymer fibers for application in nanogenerators," *Nano Energy*, vol. 62, pp. 594–600, Aug. 2019. [Online]. Available: <http://www.sciencedirect.com/science/article/pii/S2211285519304501>
- [127] F. R. Fan, W. Tang, and Z. L. Wang, "Flexible nanogenerators for energy harvesting and self-powered electronics," *Adv. Mater.*, vol. 28, no. 22, pp. 4283–4305, 2016.
- [128] X. Chen, S. Xu, N. Yao, and Y. Shi, "1.6 V nanogenerator for mechanical energy harvesting using PZT nanofibers," *Nano Lett.*, vol. 10, no. 6, pp. 2133–2137, 2010.
- [129] Z. L. Wang and J. Song, "Piezoelectric nanogenerators based on zinc oxide nanowire arrays," *Science*, vol. 312, pp. 242–246, Apr. 2006.
- [130] S. N. Cha, J.-S. Seo, S. M. Kim, H. J. Kim, Y. J. Park, S.-W. Kim, and J. M. Kim, "Sound-driven piezoelectric nanowire-based nanogenerators," *Adv. Mater.*, vol. 22, no. 42, pp. 4726–4730, 2010.
- [131] S. Bettini, R. Pagano, V. Bonfrate, E. Maglie, D. Manno, A. Serra, L. Valli, and G. Giancane, "Promising piezoelectric properties of new ZnO octadecylamine adduct," *J. Phys. Chem. C*, vol. 119, no. 34, pp. 20143–20149, 2015.
- [132] D. Choi, M.-Y. Choi, W. M. Choi, H.-J. Shin, H.-K. Park, J.-S. Seo, J. Park, S.-M. Yoon, S. J. Chae, Y. H. Lee, S.-W. Kim, J.-Y. Choi, S. Y. Lee, and J. M. Kim, "Fully rollable transparent nanogenerators based on graphene electrodes," *Adv. Mater.*, vol. 22, no. 19, pp. 2187–2192, 2010.
- [133] X. Wang, J. Song, F. Zhang, C. He, Z. Hu, and Z. Wang, "Electricity generation based on one-dimensional group-III nitride nanomaterials," *Adv. Mater.*, vol. 22, no. 19, pp. 2155–2158, 2010.
- [134] Y.-F. Lin, J. Song, Y. Ding, S.-Y. Lu, and Z. L. Wang, "Alternating the output of a CdS nanowire nanogenerator by a white-light-stimulated optoelectronic effect," *Adv. Mater.*, vol. 20, no. 16, pp. 3127–3130, 2008.
- [135] M.-Y. Lu, J. Song, M.-P. Lu, C.-Y. Lee, L.-J. Chen, and Z. L. Wang, "ZnO-ZnS heterojunction and ZnS nanowire arrays for electricity generation," *ACS Nano*, vol. 3, no. 2, pp. 357–362, 2009.
- [136] N. Soin, T. H. Shah, S. C. Anand, J. Geng, W. Pornwannachai, P. Mandal, D. Reid, S. Sharma, R. L. Hadimani, and D. V. Bayramol, "Novel '3-D spacer' all fibre piezoelectric textiles for energy harvesting applications," *Energy Environ. Sci.*, vol. 7, no. 5, pp. 1670–1679, 2014.
- [137] W. Zeng, X.-M. Tao, S. Chen, S. Shang, H. L. W. Chan, and S. H. Choy, "Highly durable all-fiber nanogenerator for mechanical energy harvesting," *Energy Environ. Sci.*, vol. 6, no. 9, pp. 2631–2638, 2013.
- [138] J.-H. Lee, K. Y. Lee, B. Kumar, N. T. Tien, N.-E. Lee, and S.-W. Kim, "Highly sensitive stretchable transparent piezoelectric nanogenerators," *Energy Environ. Sci.*, vol. 6, no. 1, pp. 169–175, 2013.
- [139] M. M. Abolhasani, K. Shirvanimoghaddam, and M. Naebe, "PVDF/graphene composite nanofibers with enhanced piezoelectric performance for development of robust nanogenerators," *Compos. Sci. Technol.*, vol. 138, pp. 49–56, Jan. 2017.
- [140] M. M. Abolhasani, M. Naebe, and Q. Guo, "A new approach for mechanisms of ferroelectric crystalline phase formation in PVDF nanocomposites," *Phys. Chem. Chem. Phys.*, vol. 16, no. 22, pp. 10679–10687, 2014.
- [141] M. M. Abolhasani, M. R. Abadchi, K. Magniez, and Q. Guo, "Different thermal analysis technique application in determination of fold surface-free energy," *J. Therm. Anal. Calorimetry*, vol. 119, no. 1, pp. 527–536, 2015.
- [142] B. Lin and V. Giurgiutiu, "Modeling and testing of PZT and PVDF piezoelectric wafer active sensors," *Smart Mater. Struct.*, vol. 15, no. 4, p. 1085, 2006.
- [143] L. Capineri, L. Masotti, V. Ferrari, D. Marioli, A. Taroni, and M. Mazzoni, "Comparisons between PZT and PVDF thick films technologies in the design of low-cost pyroelectric sensors," *Rev. Sci. Instrum.*, vol. 75, no. 11, pp. 4906–4910, 2004.
- [144] E. L. Nix and I. M. Ward, "The measurement of the shear piezoelectric coefficients of polyvinylidene fluoride," *Ferroelectrics*, vol. 67, no. 1, pp. 137–141, 1986.
- [145] R. Fu, S. Chen, Y. Lin, Y. He, and Y. Gu, "Preparation and piezoelectric investigation of electrospun polyvinylidene fluoride fibrous membrane," *J. Nanosci. Nanotechnol.*, vol. 16, no. 12, pp. 12337–12343, 2016.
- [146] H. Yu, T. Huang, M. Lu, M. Mao, Q. Zhang, and H. Wang, "Enhanced power output of an electrospun PVDF/MWCNTs-based nanogenerator by tuning its conductivity," *Nanotechnology*, vol. 24, no. 40, 2013, Art. no. 405401.
- [147] M. A. Rahman, B.-C. Lee, D.-T. Phan, and G.-S. Chung, "Fabrication and characterization of highly efficient flexible energy harvesters using PVDF-graphene nanocomposites," *Smart Mater. Struct.*, vol. 22, no. 8, 2013, Art. no. 085017.
- [148] Alamusi, J. Xue, L. Wu, N. Hu, J. Qiu, C. Chang, S. Atobe, H. Fukunaga, T. Watanabe, Y. Liu, H. Ning, J. Li, Y. Li, and Y. Zhao, "Evaluation of piezoelectric property of reduced graphene oxide (rGO)-poly(vinylidene fluoride) nanocomposites," *Nanoscale*, vol. 4, no. 22, pp. 7250–7255, 2012.
- [149] J. S. Lee, K.-Y. Shin, C. Kim, and J. Jang, "Enhanced frequency response of a highly transparent PVDF-graphene based thin film acoustic actuator," *Chem. Commun.*, vol. 49, no. 94, pp. 11047–11049, 2013.
- [150] L. Wu, Alamusi, J. Xue, T. Itoi, N. Hu, Y. Li, C. Yan, J. Qiu, H. Ning, W. Yuan, and B. Gu, "Improved energy harvesting capability of poly(vinylidene fluoride) films modified by reduced graphene oxide," *J. Intell. Mater. Syst. Struct.*, vol. 25, no. 14, pp. 1813–1824, 2014.
- [151] S. Ansari and E. P. Giannelis, "Functionalized graphene sheet—Poly(vinylidene fluoride) conductive nanocomposites," *J. Polym. Sci. B, Polym. Phys.*, vol. 47, no. 9, pp. 888–897, 2009.
- [152] R. K. Layek, S. Samanta, D. P. Chatterjee, and A. K. Nandi, "Physical and mechanical properties of poly(methyl methacrylate)-functionalized graphene/poly(vinylidene fluoride) nanocomposites: Piezoelectric  $\beta$  polymorph formation," *Polymer*, vol. 51, no. 24, pp. 5846–5856, 2010.
- [153] C. M. Wu and M. H. Chou, "Sound absorption of electrospun polyvinylidene fluoride/graphene membranes," *Eur. Polym. J.*, vol. 82, pp. 35–45, Sep. 2016.
- [154] S. Mishra, L. Unnikrishnan, S. K. Nayak, and S. Mohanty, "Advances in piezoelectric polymer composites for energy harvesting applications: A systematic review," *Macromol. Mater. Eng.*, vol. 304, no. 1, 2019, Art. no. 1800463.
- [155] Z. Yang, S. Zhou, J. Zu, and D. Inman, "High-performance piezoelectric energy harvesters and their applications," *Joule*, vol. 2, no. 4, pp. 642–697, 2018.
- [156] Avnet. (2016). *Powering the Internet of Things Via Energy Harvesting*. [Online]. Available: <http://design.avnet.com/axiom/powering-the-internet-of-things-via-energy-harvesting/>
- [157] A. Cammarano, C. Petrioli, and D. Spenza, "Online energy harvesting prediction in environmentally powered wireless sensor networks," *IEEE Sensors J.*, vol. 16, no. 17, pp. 6793–6804, Sep. 2016.
- [158] J. R. Piorno, C. Bergonzini, D. Atienza, and T. S. Rosing, "Prediction and management in energy harvested wireless sensor nodes," in *Proc. 1st Int. Conf. Wireless Commun., Veh. Technol., Inf. Theory Aerosp. Electron. Syst. Technol.*, May 2009, pp. 6–10.
- [159] C. Bergonzini, D. Brunelli, and L. Benini, "Algorithms for harvested energy prediction in batteryless wireless sensor networks," in *Proc. 3rd Int. Workshop Adv. Sensors Interfaces*, Jun. 2009, pp. 144–149.
- [160] N. Sharma, J. Gummesson, D. Irwin, and P. Shenoy, "Cloudy computing: Leveraging weather forecasts in energy harvesting sensor systems," in *Proc. 7th Annu. IEEE Commun. Soc. Conf. Sensor, Mesh Ad Hoc Commun. Netw. (SECON)*, Jun. 2010, pp. 1–9.
- [161] V. Sharma, U. Mukherji, V. Joseph, and S. Gupta, "Optimal energy management policies for energy harvesting sensor nodes," *IEEE Trans. Wireless Commun.*, vol. 9, no. 4, pp. 1326–1336, Apr. 2010.
- [162] S. Baghaee, S. Chamanian, H. Ullusan, O. Zorlu, E. Uysal-Biyikoglu, and H. Kulah, "Demonstration of energy-neutral operation on a WSN testbed using vibration energy harvesting," in *Proc. 20th Eur. Wireless Conf. Eur. Wireless*, May 2014, pp. 1–6.
- [163] Cypress Core&Code. (2015). *Energy-Harvesting Devices Replace Batteries in IoT Sensors*. [Online]. Available: <http://core.spansion.com/article/energy-harvesting-devices-replace-batteries-in-iot-sensors/#.WckfFC195aQ>
- [164] Y. Shu, K. G. Shin, J. Chen, and Y. Sun, "Joint energy replenishment and operation scheduling in wireless rechargeable sensor networks," *IEEE Trans. Ind. Informat.*, vol. 13, no. 1, pp. 125–134, Feb. 2017.

- [165] C. Alippi, G. Anastasi, M. Di Francesco, and M. Roveri, "Energy management in wireless sensor networks with energy-hungry sensors," *IEEE Instrum. Meas. Mag.*, vol. 12, no. 2, pp. 16–23, Apr. 2009.
- [166] D. Zhang, Z. Chen, H. Zhou, L. Chen, and X. Shen, "Energy-balanced cooperative transmission based on relay selection and power control in energy harvesting wireless sensor network," *Comput. Netw.*, vol. 104, pp. 189–197, Jul. 2016.
- [167] Y. Li, L. Fu, Y. Ying, Y. Sun, K. Chi, and Y. Zhu, "Goodput optimization via dynamic frame length and charging time adaptation for backscatter communication," *Peer-Peer Netw. Appl.*, vol. 10, no. 3, pp. 440–452, May 2017.
- [168] Q. Tan, W. An, Y. Han, Y. Liu, S. Ci, F.-M. Shao, and H. Tang, "Energy harvesting aware topology control with power adaptation in wireless sensor networks," *Ad Hoc Netw.*, vol. 27, pp. 44–56, Apr. 2015.
- [169] Battery University. (2019). *BU-209: How Does a Supercapacitor Work?*. [Online]. Available: [https://batteryuniversity.com/learn/article/whats\\_the\\_role\\_of\\_the\\_supercapacitor](https://batteryuniversity.com/learn/article/whats_the_role_of_the_supercapacitor)
- [170] D. Mallick, A. Amann, and S. Roy, "Surfing the high energy output branch of nonlinear energy harvesters," *Phys. Rev. Lett.*, vol. 117, no. 19, 2016, Art. no. 197701.
- [171] J. Park, S. Lee, and B. M. Kwak, "Design optimization of piezoelectric energy harvester subject to tip excitation," *J. Mech. Sci. Technol.*, vol. 26, no. 1, pp. 137–143, Jan. 2012.
- [172] S. Paquin and Y. St-Amant, "Improving the performance of a piezoelectric energy harvester using a variable thickness beam," *Smart Mater. Struct.*, vol. 19, no. 10, 2010, Art. no. 105020.
- [173] S. B. Ayed, A. Abdelkefi, F. Najar, and M. R. Hajj, "Design and performance of variable-shaped piezoelectric energy harvesters," *J. Intell. Mater. Syst. Struct.*, vol. 25, no. 2, pp. 174–186, Jan. 2014.
- [174] S. S. Nanthakumar, T. Lahmer, X. Zhuang, H. S. Park, and T. Rabczuk, "Topology optimization of piezoelectric nanostructures," *J. Mech. Phys. Solids*, vol. 94, pp. 316–335, Sep. 2016.
- [175] F. Wein, M. Kaltenbacher, and M. Stingl, "Topology optimization of a cantilevered piezoelectric energy harvester using stress norm constraints," *Struct. Multidisciplinary Optim.*, vol. 48, no. 1, pp. 173–185, 2013.
- [176] Z. Yang, Y. Q. Wang, L. Zuo, and J. Zu, "Introducing arc-shaped piezoelectric elements into energy harvesters," *Energy Convers. Manage.*, vol. 148, pp. 260–266, Sep. 2017.
- [177] S. Du, Y. Jia, S.-T. Chen, C. Zhao, B. Sun, E. Arroyo, and A. A. Seshia, "A new electrode design method in piezoelectric vibration energy harvesters to maximize output power," *Sens. Actuators A, Phys.*, vol. 263, pp. 693–701, Aug. 2017.
- [178] O. B. Akan, O. Cetinkaya, C. Koca, and M. Ozger, "Internet of hybrid energy harvesting things," *IEEE Internet Things J.*, vol. 5, no. 2, pp. 736–746, Apr. 2018.
- [179] J. An, K. Yang, J. Wu, N. Ye, S. Guo, and Z. Liao, "Achieving sustainable ultra-dense heterogeneous networks for 5G," *IEEE Commun. Mag.*, vol. 55, no. 12, pp. 84–90, Dec. 2017.
- [180] Y. Alsaba, S. K. A. Rahim, and C. Y. Leow, "Beamforming in wireless energy harvesting communications systems: A survey," *IEEE Commun. Surveys Tuts.*, vol. 20, no. 2, pp. 1329–1360, 2nd Quart., 2018.
- [181] D. Niyato, D. I. Kim, M. Maso, and Z. Han, "Wireless powered communication networks: Research directions and technological approaches," *IEEE Wireless Commun.*, vol. 24, no. 6, pp. 88–97, Dec. 2017.
- [182] K. Yang, N. Yang, N. Ye, M. Jia, Z. Gao, and R. Fan, "Non-orthogonal multiple access: Achieving sustainable future radio access," *IEEE Commun. Mag.*, vol. 57, no. 2, pp. 116–121, Feb. 2019.
- [183] A. A. Khan, M. H. Rehmani, and A. Rachedi, "Cognitive-radio-based Internet of Things: Applications, architectures, spectrum related functionalities, and future research directions," *IEEE Wireless Commun.*, vol. 24, no. 3, pp. 17–25, 2017.
- [184] D. T. Hoang, D. Niyato, P. Wang, D. I. Kim, and Z. Han, "Ambient backscatter: A new approach to improve network performance for RF-powered cognitive radio networks," *IEEE Trans. Commun.*, vol. 65, no. 9, pp. 3659–3674, Sep. 2017.
- [185] X. Gao, P. Wang, D. Niyato, K. Yang, and J. An, "Auction-based time scheduling for backscatter-aided RF-powered cognitive radio networks," *IEEE Trans. Wireless Commun.*, vol. 18, no. 3, pp. 1684–1697, Mar. 2019.
- [186] K. Yang, S. Martin, C. Xing, J. Wu, and R. Fan, "Energy-efficient power control for device-to-device communications," *IEEE J. Sel. Areas Commun.*, vol. 34, no. 12, pp. 3208–3220, Dec. 2016.
- [187] W. Zhou, Y. Jia, A. Peng, Y. Zhang, and P. Liu, "The effect of IoT new features on security and privacy: New threats, existing solutions, and challenges yet to be solved," *IEEE Internet Things J.*, vol. 6, no. 2, pp. 1606–1616, Apr. 2019.
- [188] S. Li, T. Tryfonas, and H. Li, "The Internet of Things: A security point of view," *Internet Res.*, vol. 26, no. 2, pp. 337–359, 2016.
- [189] J. Lin, W. Yu, N. Zhang, X. Yang, H. Zhang, and W. Zhao, "A survey on Internet of things: Architecture, enabling technologies, security and privacy, and applications," *IEEE Internet Things J.*, vol. 4, no. 5, pp. 1125–1142, Oct. 2017.
- [190] K. Fu, T. Kohno, D. Lopresti, E. Mynatt, K. Nahrstedt, S. Patel, D. Richardson, and B. Zorn, "Safety, security, and privacy threats posed by accelerating trends in the Internet of Things," Comput. Community Consortium, Tech. Rep., 2017. [Online]. Available: <http://cra.org/ccc/wp-content/uploads/sites/2/2017/02/Safety-Security-and-Privacy-Threats-in-IoT.pdf>
- [191] R. Roman, J. Zhou, and J. Lopez, "On the features and challenges of security and privacy in distributed Internet of Things," *Comput. Netw.*, vol. 57, no. 10, pp. 2266–2279, 2013.
- [192] S. Sicari, A. Rizzardi, L. A. Grieco, and A. Coen-Porisini, "Security, privacy and trust in Internet of Things: The road ahead," *Comput. Netw.*, vol. 76, pp. 146–164, Jan. 2015.
- [193] Y. Yang, L. Wu, G. Yin, L. Li, and H. Zhao, "A survey on security and privacy issues in Internet-of-Things," *IEEE Internet Things J.*, vol. 4, no. 5, pp. 1250–1258, Oct. 2017.
- [194] IDTechEx. (2011). *Energy Harvesting and Storage for Electronic Devices 2011–2021*. [Online]. Available: <http://www.idtechex.com/research/reports/energy-harvesting-and-storage-for-electronic-devices-2011-2021-000270.asp>
- [195] Gartner. (2014). *Gartner Says the Internet of Things Will Transform the Data Center*. [Online]. Available: <http://www.gartner.com/newsroom/id/2684616>
- [196] Intel. (2017). *Guide to IoT*. [Online]. Available: <http://www.intel.com/content/www/us/en/internet-of-things/infographics/guide-to-iot.html>
- [197] Business Wire. (2016). *Global Energy Harvesting Market Worth USD 3.3 Billion by 2020—Analysis, Technologies & Forecasts Report 2016–2020—Research and Markets*. [Online]. Available: <http://www.businesswire.com/news/home/20160607006433/en/Global-Energy-Harvesting-Market-Worth-USD-3.3>
- [198] Future Market Insight. (2017). *Energy Harvesting Market: Global Industry Analysis and Opportunity Assessment 2014–2020*. [Online]. Available: <https://www.futuremarketinsights.com/reports/global-energy-harvesting-market>
- [199] Transparency Market Research. (2017). *Piezoelectric Energy Harvesting Market—Global Industry Analysis, Size, Share, Trends, Analysis, Growth and Forecast, 2016–2023*. [Online]. Available: <https://www.transparencymarketresearch.com/piezoelectric-energy-harvesting-market.html>
- [200] R. Das. (2012). *Piezoelectric Energy Harvesting Market to Reach \$145 Million in 2018*. [Online]. Available: <https://www.energyharvestingjournal.com/articles/4664/piezoelectric-energy-harvesting-market-to-reach-145-million-in-2018>



**MAHYAR SHIRVANIMOGHADDAM** (S'12–M'15) received the B.Sc. degree (Hons.) from the University of Tehran, Iran, in 2008, the M.Sc. degree (Hons.) from Sharif University of Technology, Iran, in 2010, and the Ph.D. degree from The University of Sydney, Australia, in 2015, all in electrical engineering. He held a postdoctoral research position with the School of Electrical Engineering and Computer Science, University of Newcastle, Australia. Since 2016, he has been with

the School of Electrical and Information Engineering, The University of Sydney, as an Academic Fellow in telecommunications. His general research interests include channel coding techniques, cooperative communications, compressed sensing, machine-to-machine communications, and wireless sensor networks. He was selected as an Exemplary Reviewer of the IEEE COMMUNICATIONS LETTERS and the IEEE TRANSACTIONS ON COMMUNICATIONS.





**KAMYAR SHIRVANIMOGHADDAM** received the Ph.D. degree from the Institute for Frontier Materials, Deakin University, Australia, in 2019. He was a Materials Scientist in different companies and universities, since 2004, when he graduated from the University of Tehran, Iran. His research interests include developing new periodical patterned CNT for high-tech applications such as sensors and nanogenerators. His expertise includes carbonaceous structure, composite materials, and piezoelectric polymers.



**MOHAMMAD MAHDI ABOLHASANI** received the Ph.D. degree in polymer engineering from Amirkabir University of Technology, Tehran, Iran. His Ph.D. research work contributed to the demonstration of effects of nanofillers and dynamic vulcanization on crystalline polymorphism of PVDF. Then, he joined University of Kashan, Iran, as an Assistant Professor. His work at Kashan was focused on investigation of piezoelectric performance of PVDF films and fibers. In 2014, he did a Postdoctoral with Deakin University, Australia. In 2016, he received a fellowship from the Alexander von Humboldt Foundation for a project on high-K ferroelectric polymers for energy storage application. He is currently a Postdoctoral Researcher with Max-Planck institute for polymer research, Germany.



**MAJID FARHANGI** received the B.Sc. degree in electrical engineering from the IAUCTB, Tehran, Iran, in 2015. He is currently pursuing the master's degree in electrical engineering from The University of Sydney, Australia. His current research interests include high-efficiency DC – DC converters, wireless power transmission, and high frequency induction heating systems.



**VAHID ZAHIRI BARSARI** received the B.Sc. degree in electrical engineering from IAUCTB, Tehran, Iran, in 2015, and the M.Eng. degree in electrical engineering from The University of Sydney, Sydney, Australia, in 2018. He is currently pursuing the Ph.D. degree in electrical and electronic engineering with The University of Auckland, Auckland, New Zealand. His research interests include power electronics, renewable energy technology, and inductive power transfer systems for electric vehicle charging in both stationary and dynamic scenarios.



**HANGYUE LIU** (S'16) received the B.E. degree in electrical engineering from SouthWest Jiaotong University, Chengdu, China, in 2014, and the M.E. degree in electrical engineering from The University of Sydney, Sydney, Australia, in 2017. His current research interests include demand response, energy management in residential buildings, and applications of IoT in smart grid.



**MISCHA DOHLER** (S'99 – M'03 – SM'07 – F'14) is currently a Full Professor in wireless communications with King's College London, the Head of the Centre for Telecommunications Research, and a Co-Founder and a Member of the Board of Directors of the smart city pioneer WorldSensing. He was a Distinguished Lecturer of the IEEE. He was the Editor-in-Chief of the TRANSACTIONS ON EMERGING TELECOMMUNICATIONS TECHNOLOGIES and the TRANSACTIONS ON THE INTERNET OF THINGS.

He is a frequent keynote, panel and tutorial speaker, and has received numerous awards. He has pioneered several research fields, contributed to numerous wireless broadband, IoT/M2M and a cyber security standards, holds a dozen of patents, organized, and chaired numerous conferences, has more than 200 publications, and authored several books.

He acts as policy, technology and entrepreneurship adviser, examples being Richard Branson's Carbon War Room, House of Parliament U.K., U.K. Ministry BIS, EPSRC ICT Strategy Advisory Team, European Commission, Tech London Advocate, ISO Smart City working group, and various start-ups. He is also an entrepreneur, angel investor, passionate pianist and fluent in 6 languages. He has talked at TEDx. He had coverage by national and international TV and radio; and his contributions have featured on BBC News and the Wall Street Journal.



**MINOO NAEBE** received the B.Sc. (Hons.) and M.S. degrees from the Isfahan University of Technology (IUT), Isfahan, Iran, and the Ph.D. degree from Deakin University, Australia (2008). She is an Associate Professor and the Theme Leader for High Performance Materials with Carbon Nexus, Institute for Frontier Materials, Deakin University. Her research interests include advanced polymer (nano) composites and fibers and applications in various industries aerospace, automotive, and oil and gas.

...