

Received May 9, 2019, accepted May 27, 2019, date of publication June 17, 2019, date of current version July 12, 2019.

Digital Object Identifier 10.1109/ACCESS.2019.2923266

A Novel Coordinated Medium Access Control Scheme for Vehicular Ad Hoc Networks in Multichannel Environment

SHENGBIN CAO¹ AND VICTOR C. S. LEE¹, (Member, IEEE)

Department of Computer Science, City University of Hong Kong, Hong Kong

Corresponding author: Victor C. S. Lee (csvlee@cityu.edu.hk)

This work was supported by the City University of Hong Kong under Project 7004888.

ABSTRACT Vehicular ad-hoc networks (VANETs) aim to provide efficient safety and infotainment services. Wireless Access in Vehicular Environments (WAVE), which is a standard designed specifically for VANETs, stipulates seven 10-MHz channels: one control channel (CCH) for safety message transmission and six service channels (SCHs) for service message transmission. However, providing reliable broadcasting of safety messages on the CCH and efficient coordination of vehicles for service message transmission across the multiple SCHs in highly dynamic VANET environment is a nontrivial problem. In this paper, we propose a coordinated, adaptive, and reliable multichannel medium-access control scheme for the VANETs (VCAR-MAC). In VCAR-MAC, a novel time-division multiple access (TDMA)-based scheme that considers real-world environmental conditions is proposed to identify every vehicle quickly so that a time slot on the CCH can be allocated efficiently for reliable safety message transmission. On the SCHs, VCAR-MAC provides a multi-SCH coordination scheme, which adaptively adjusts the SCH reservation period in order to fully utilize the channel bandwidth. Furthermore, a dynamic contention window (CW) mechanism is proposed, in which the initial CW size is adaptively optimized to maximize the number of successful SCH reservations, thereby maximizing the service message throughput. It has been proven via the mathematical analysis and simulation experiment that VCAR-MAC can significantly improve throughput and reduce delay for both safety and service messages.

INDEX TERMS MAC scheme, vehicular ad-hoc networks (VANETs), safety and service applications.

I. INTRODUCTION

Recently, the research demand regarding Vehicular Ad-hoc Networks (VANETs) has been arising in industrial and academic fields in view of their great potential to support safety and infotainment services [1]–[4]. There are two major components in VANETs: On Board Unit (OBU) and Road-side Unit (RSU) [5]. The OBU is a communication device mounted on a vehicle to operate as a mobile node. The RSU, which is an infrastructure that can be located at any fixed point of interest on the road, provides vehicles with Internet access. Communication between an RSU and an OBU is referred to as Vehicle-to-Infrastructure (V2I) communication, and communication among OBUs is referred to as Vehicle-to-Vehicle (V2V) communication [6].

The associate editor coordinating the review of this manuscript and approving it for publication was Mohammad S. Khan.

Wireless Access in Vehicular Environments (WAVE) is a standard specifically designed for VANETs. WAVE includes the IEEE 802.11p [7] and the IEEE 1609.4 [8] standards. The IEEE 802.11p describes Medium Access Control (MAC) layer and Physical (PHY) layer characteristics, and the IEEE 1609.4 specifies the multichannel operation.

For the multi-channel operation, the WAVE stipulates seven 10 MHz frequency channels in the 5.9GHz band: one Control Channel (CCH) and six Service Channels (SCHs), as shown in Fig. 1. The CCH is a public channel, on which vehicles broadcast safety and SCH reservation messages. The safety message contains vehicle ID, velocity, and position information of a sending vehicle in order to create cooperative neighborhood awareness [3]. The SCH reservation message, referred to as Wave Service Advertisement (WSA) message in the WAVE standard, is used for a vehicle to announce a service and reserve a SCH to provide the service.

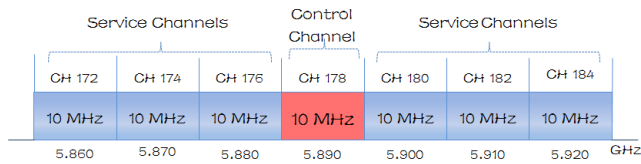

FIGURE 1. Multiple channels of WAVE system.

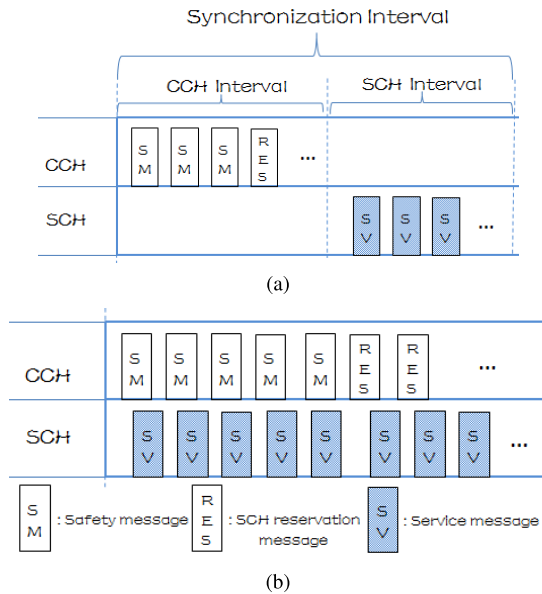

FIGURE 2. Multichannel operation with (a) single radio device and (b) dual radio device.

Then, the service message of the announced service is transmitted on the reserved SCH. In this paper, we consider a MAC scheme, which supports both safety and non-safety applications. In order to satisfy the Quality-of-Service (QoS) requirements of safety-related applications, the delivery delay of the safety message needs to be less than 100 ms, with a successful delivery probability of higher than 98% [3]. Also, for non-safety applications, a large throughput and fairly short delivery delay of the service message are required. However, the unique characteristics of VANETs such as fast topology change and high node mobility increase the challenges in the design of a MAC scheme that maximizes the throughput of safety and service messages, while satisfying the QoS requirements.

Vehicles can be equipped with either single-radio or dual-radio device. With a single-radio device, a vehicle can only operate on one wireless channel at a time, whereas using a dual-radio device, a vehicle is able to simultaneously operate on the control channel and one of the service channels. For a MAC scheme designed for a single-radio device, the channel time is partitioned into synchronization intervals (SIs) with a fixed length of 100 ms, while each SI consists of a CCH Interval (CCHI) and an SCH Interval (SCHI), with the length of 50 ms and 50 ms, respectively, as specified by 1609.4 standard (Fig. 2(a)). During CCHI, all vehicles tune to the CCH for the transmission/reception of safety and SCH reservation

messages, and during SCHI, vehicles can switch to one of the SCHs to transmit/receive service messages. In contrast, using a dual-radio device, a vehicle is able to send/receive messages on two channels simultaneously. One example of dual-radio usage is shown in Fig. 2b, where one radio is tuned on the CCH, while the other radio is switchable among the six SCHs.

One drawback of the single-radio usage is the wastage of the SCH bandwidth during CCHI, due to the lack of simultaneous channel operation. Furthermore, several research works [9]–[12] discovered that dividing the available channel bandwidth may not satisfy the QoS requirements of safety services. Hence, dual-radio devices are expected to be a long-term solution in vehicular networks [12]. However, how to coordinate the operations of two radios and multiple channels in order to fully utilize the potential of the channel spectrum, while satisfying QoS requirements of safety-related applications, is a non-trivial problem [13].

In this work, we propose a Coordinated, Adaptive and Reliable MAC scheme for VANETs (VCAR-MAC), using a dual-radio device. Our main contributions can be summarized as follows:

- Dual-radio-based VANET MAC scheme: Dual-radio devices are expected to be deployed as a long-term solution for VANETs, enabling vehicles to continuously monitor the CCH while transmitting/receiving service messages on the SCHs [12], [13]. However, regardless of this strength, MAC schemes using dual radios have been less explored due to the higher level of implementation complexity. In order to exploit the strength of dual-radio devices for VANETs, we propose a dual-radio-based MAC scheme that supports reliable safety message and efficient service message transmissions.
- Novel Time Division Multiple Access (TDMA)-based safety message transmission scheme: By taking account of the environmental conditions and analyzing the TDMA time slot contention, the number of vehicles currently located within the RSU coverage can be accurately derived. Accordingly, the optimal number of time slots for which vehicles contend can be determined to minimize the chance of access collision. As a result, each vehicle that can successfully access a time slot can be efficiently identified by the RSU and be allocated a time slot for collision-free safety message transmission.
- Multichannel coordination scheme: Based on the number of identified vehicles, the channel contention level can be forecasted. Then, a multichannel coordination scheme, which uses a Markov-chain-based model considering the effect of environmental conditions, is used to accurately adjust the SCH reservation period to fully utilize the channel bandwidth.
- Dynamic CW mechanism: As the number of vehicles contending for SCH reservations increases, the contention level increases, leading to a reduction in the number of successful SCH reservations. In order to keep the number of successful SCH reservations on the maximum

level, the initial CW size is adaptively adjusted, thereby maximizing the service message throughput.

- Analytical model: An analytical model is formulated for transmission delay and throughput of service message in the proposed VCAR-MAC. Then, through simulation experiment, we verify the analytical model and evaluate the performance of VCAR-MAC. It is shown that VCAR-MAC significantly improves the performance in terms of transmission delay and throughput for both safety and service messages compared to previously proposed schemes.

The remainder of this paper is organized as follows: In Section II, related works are introduced. Section III describes the proposed VCAR-MAC. In Section IV, the performance of the VCAR-MAC is evaluated by analytical model and simulation experiment. The conclusion is provided in Section V.

II. RELATED WORKS

In [14], Dang *et al.* propose a multichannel MAC scheme that uses a single-radio device. Vehicles transmit safety and SCH reservation messages on the CCH during CCHI, and service messages on the SCHs during SCHI, based on the IEEE 802.11 DCF-based contention [7] (Fig. 2(a)). In order to increase the reliability of safety messages, it is proposed that vehicles send extra safety messages on the CCH during SCHI. However, these extra transmitted messages result in higher message collision probability. Moreover, since a single-radio device is used, vehicles that tune the radio to the SCHs cannot hear the safety messages transmitted on the CCH.

In [15], a reliable multichannel MAC scheme is proposed to provide a contention-free safety message transmission. The CCHI is divided into two parts: (i) safety message transmission period, which is the period dedicated for safety message transmission and (ii) SCH reservation period, which is the period for SCH reservation message transmission. The safety message transmission period is further divided into multiple time slots and each vehicle contends for these time slots for safety message transmission based on reliable reservation ALOHA (RR-ALOHA) [16]. In the RR-ALOHA-based scheme, the slot occupancy information is exchanged via safety messages. Thus, a vehicle is able to know which time slot is unoccupied by listening to the messages transmitted by its neighbors. However, these additional information can cause large overhead.

In [17], Wang *et al.* propose an Variable Channel Interval (VCI) algorithm. Similar to [15], the CCHI is divided into safety message transmission period and SCH reservation period. Each vehicle can only transmit one service message for a successful channel reservation. According to the number of vehicles within the RSU coverage, an RSU uses VCI algorithm to derive the optimal ratio of the duration of SCH reservation period to the duration of service message transmission period, i.e., SCHI. The optimal ratio aims to make the expected number of successful SCH reservations made

during SCH reservation period equal to the number of service messages transmitted during the service message transmission period in order to fully utilize the channel bandwidth. The dynamic VCI algorithm can significantly improve the service message throughput compared to WAVE. However, their algorithm ignores the effect of real environmental conditions. If these environmental conditions are not considered, the ratio optimization is inaccurate, resulting in the channel shortage and wastage problems. The channel shortage problem occurs when the service message transmission period is too short to accommodate all the successful SCH reservations. Contrarily, the channel wastage problem occurs when service message transmission period is longer than required to accommodate all the successful SCH reservations.

In [11], the authors propose two TDMA-based MAC schemes, namely, Random Vehicle Selection (RVS) scheme and Least Residual Residence Time (LRT) scheme. The time of channel is divided into time slots. In RVS scheme, at the start of each time slot, the RSU transmits a control message indicating a vehicle that is uniformly selected from the vehicles present within its coverage to transmit a message during that time slot. In the next time slot, the RSU will perform another random selection and so forth. Hence, all the vehicles have equal chance to be selected and granted access to the channel, thereby ensuring the fairness of channel access. In LRT scheme, for each time slot, the RSU allows the vehicle that have the least residual residence time to transmit a message. Since both RVS and LRT enable contention- and collision-free message transmission in each time slot, the successful message transmission probability and channel utilization can be largely increased compared to a contention-based scheme. Therefore, these schemes can provide reliable safety message transmission in VANETs. However, in their work, it is assumed that the RSU are aware of the information (e.g., vehicle ID, current driving speed) of each of the vehicles present within its coverage, which, in fact, is hardly possible in reality. Furthermore, since at the start of each time slot, the RSU has to transmit a control message, the coordination overhead is very large.

In [12], Kim *et al.* propose a contention- and reservation-based MAC scheme that uses a dual-radio device, which is referred to as CR-MAC herein. In CR-MAC, one radio operates on the CCH and the other radio switches among six SCHs. Vehicles contend to transmit safety and SCH reservation messages based on the IEEE 802.11 DCF on the CCH. The RSU sends back an acknowledgement (ack) message if a safety message is successfully received. Hence, a safety message can be retransmitted several times until successfully delivered to increase the successful transmission probability. In order to reserve an SCH, each vehicle transmits an SCH reservation message to the RSU. If the RSU successfully receives the message, it accepts or rejects based on SCH availability. CR-MAC significantly improves successful transmission probability of safety message and throughput of service message. However, since both safety messages and

SCH reservation messages contend for channel access on the CCH based on the DCF, channel access delay increases rapidly as the number of vehicles increases.

III. VCAR-MAC SCHEME

In this section, we present our proposed VCAR-MAC scheme. This section gives an overview of the scheme followed by a detailed description of safety-message transmission and service-message transmission, and an overhead analysis.

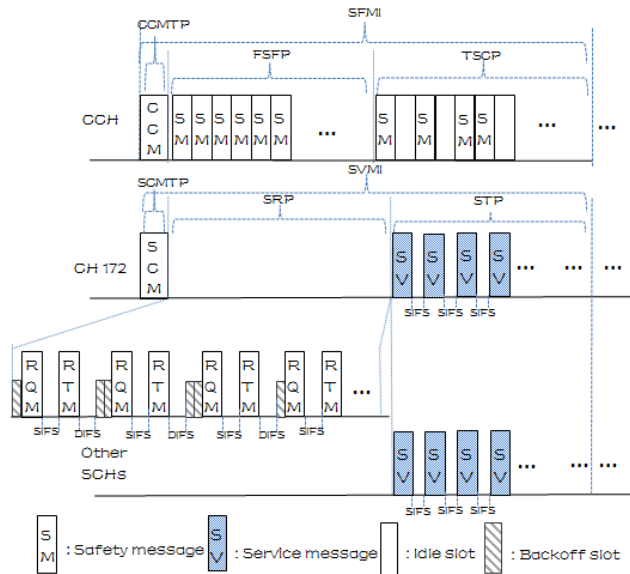

FIGURE 3. VCAR-MAC scheme.

As specified in [3], each safety message transmitted by a vehicle includes vehicle ID, velocity, and position information of the sending vehicle. RSU can be deployed at any point of interest on the road. Each vehicle and RSU has two radios: one radio is always tuned to the CCH, while the other radio alternates among the six SCHs. As shown in Fig. 3, in VCAR-MAC, the time of CCH is partitioned into variable-length, time-slotted Safety Message Transmission Intervals (SFMI), while each SFMI consists of CCH Coordination Message Transmission Period (CCMTMP), Free Safety Message Transmission Period (FSFP), and Time Slot Contention Period (TSCP); the time of SCHs is divided into fixed-length Service Message Transmission Intervals (SVMIs), while each SVMI is further divided into SCH Coordination Message Transmission Period (SCMTMP), SCH Reservation Period (SRP), and Service Message Transmission Period (STP).

On the CCH, during the CCMTMP, the RSU transmits a CCH Coordination Message (CCM), which indicates the lengths of FSFP and TSCP, and time slot allocation information of FSFP. After the CCMTMP, follows the FSFP, during which the vehicles indicated in the CCM transmit safety messages during the allocated time slots. At the end of the FSFP, begins the TSCP, during which vehicles that are not indicated in the

CCM contend for time slots to transmit safety messages. The RSU can identify a vehicle via the ID information included in the safety message if the transmitted message is successfully received. Then a time slot of the FSFP in the subsequent SFMI will be allocated to each identified vehicle. As a result, identified vehicles can transmit their safety messages during the allocated time slots without message collisions, supporting reliable safety message transmission.

On the SCHs, during the SCMTMP, the RSU transmits an SCH Coordination Message (SCM) including the length information of SRP and STP, the IDs of vehicles that are identified so far, and the initial CW size. The vehicles indicated in the SCM contend to transmit Request Message (RQM) to the RSU during SRP using the initial CW size indicated in the SCM in order to reserve an SCH for service message transmission. If the RSU successfully receives an RQM, it transmits Response to Request Message (RTM), which includes the SCH ID to be used. Then, the vehicles that successfully reserve SCHs will be able to transmit service messages during STP on their reserved SCHs.

TABLE 1. Notations for safety message transmission scheme.

Notation	Description
SFMI	Time interval that divides the CCH and includes CCMTMP, FSFP, TSCP
CCMTMP	Time period for CCM transmission
FSFP	Time period for scheduled safety message transmission
TSCP	Time period for time slot contention
CCM	Management message of SFMI
m	Fading parameter
γ	Path loss exponent
p_r	Successful detection probability
R	Transmission range
n	The number of unidentified vehicles before an SFMI, say SFMI _{i}
n_r	The number of vehicles receiving a CCM among the n unidentified vehicles
\tilde{n}_s	The expected number of success time slots perceived by the RSU at the end of SFMI _{i}
$l_{tscp,i}/l_{sfmi,i}$	The number of time slots included in TSCP _{i} /SFMI _{i}
t_{slot}	Duration of a time slot in SFMI
n_{ne}	The number of vehicles that will newly enter the RSU coverage during SFMI _{$i+1$}
\tilde{n}	The number of vehicles left to be identified during SFMI _{$i+1$}
θ	Throughput of TSCP

A. SAFETY MESSAGE TRANSMISSION

First, we describe our TDMA-based safety message transmission scheme, which is invoked at the end of each SFMI, say SFMI _{i} (see Fig. 3). The notations used for safety message transmission scheme are listed in Table 1. Also, the left part of Fig. 4 shows the flow diagram of the scheme. It includes five procedures: (i) propagation modeling procedure: using a propagation model that takes account of path loss and channel fading, the RSU derives and stores the successful detection probability, i.e., the probability that a received message's

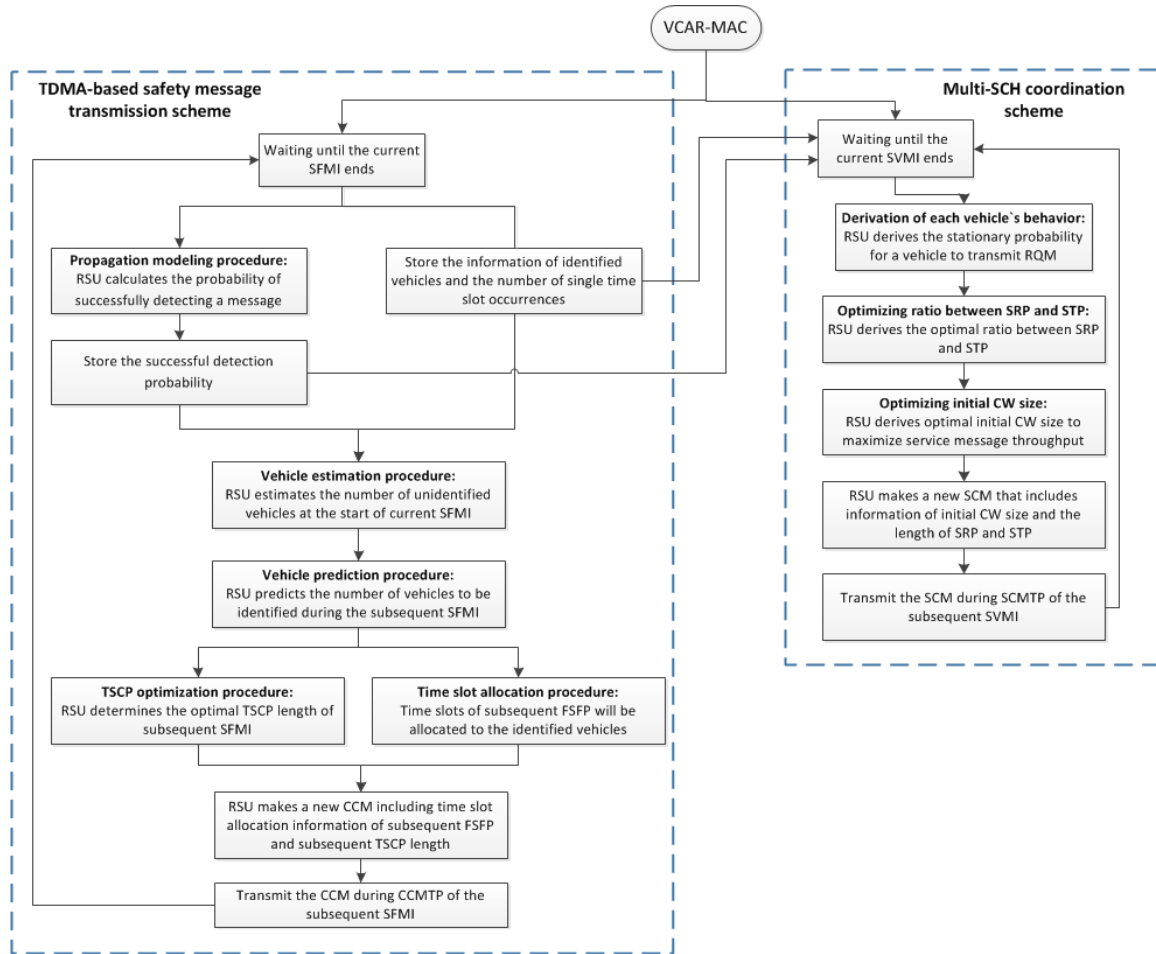

FIGURE 4. Flow diagram of VCAR-MAC.

signal power is stronger than the power reception threshold. At the same time, the RSU saves the information of identified vehicles, i.e., the vehicles that have successfully accessed a time slot of TSCP_{*i*}; (ii) vehicle estimation procedure: based on the derived successful detection probability and the number of identified vehicles, the RSU estimates the number of unidentified vehicles at the start of SFMI_{*i*}¹; (iii) vehicle prediction procedure: based on the estimated number, the RSU predicts the number of vehicles to be identified during upcoming SFMI, i.e., SFMI_{*i+1*}; (iv) TSCP optimization procedure: based on the results obtained from the previous steps, the RSU determines the optimal length of TSCP in SFMI_{*i+1*}; (v) time slot allocation procedure: the RSU allocates each identified vehicle a time slot of FSFP in SFMI_{*i+1*} for safety message transmission.

Fig. 5, shows a simplified example for the TDMA-based safety message transmission scheme in VCAR-MAC. For the sake of clarity, vehicle arrival and departure are not shown in

¹Note that this procedure estimates the number of vehicles that were not identified at the start of current SFMI, i.e., SFMI_{*i*}.

this example. It is assumed that all the vehicles, i.e., vehicles 1 through 7 are not identified at first. The scheme is invoked at the end of each SFMI. At the end of the first SFMI, the number of unidentified vehicles at the start of the first SFMI is estimated to be 7, i.e., vehicles 1 through 7 (see Fig. 5(a)). Since V1, V2, and V4 are successfully identified in the first SFMI, the number of vehicles to be identified during the second SFMI is predicted to be 4. Using the predicted number, the optimal length of TSCP of the second SFMI is determined to be 4. Then, during CCMTF of the second SFMI, the RSU transmits a CCM that includes the information of FSFP slot allocation schedule and the length of TSCP for the second SFMI. The FSFP consists of a number of time slots and each time slot is allocated to an identified vehicle. So, the number of time slots in FSFP in the second SFMI is equal to the number of vehicles identified in the first SFMI. For instance, in Fig. 5(b), V2, V1, and V4, which are successfully identified by the RSU, are allocated time slots of FSFP. Then, TSCP starts after FSFP. The TSCP includes multiple time slots and the number of time slots is announced by the CCM. V3, V5, V6, and V7, which have not been

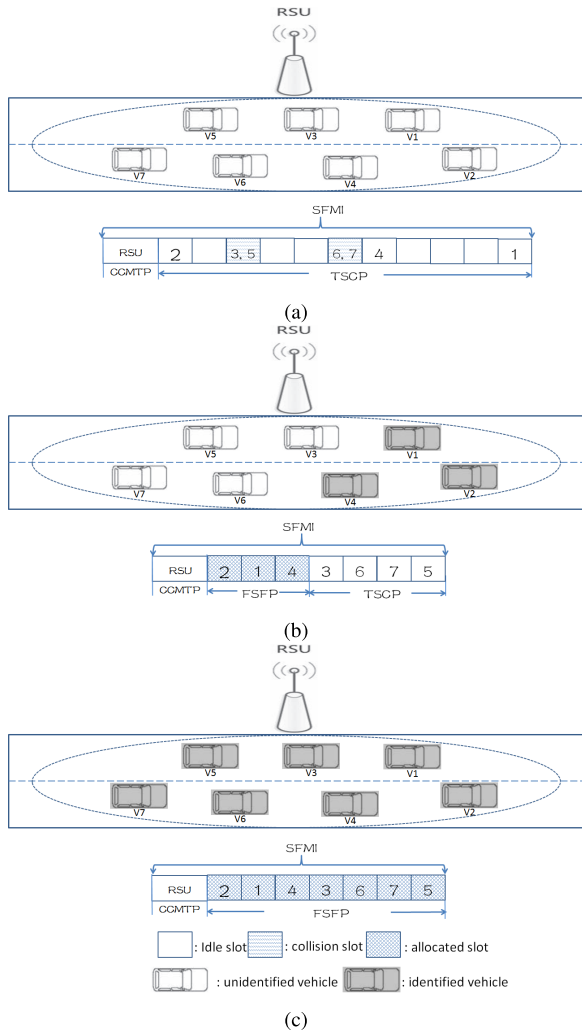

FIGURE 5. Safety message transmission scheme.

identified during the first SFMI, randomly select one time slot of TSCP to transmit safety message. Finally, at the end of the second SFMI, all the vehicles are identified (Fig. 5(b)) and will be allocated a time slot of FSFP in the third SFMI (Fig. 5(c)).

The objective of the scheme is to identify each of the vehicles within the RSU coverage as soon as possible, while maximizing the CCH throughput by optimizing the length of each TSCP.

1) PROPAGATION MODELING

Taking account of environmental conditions to derive a good estimation of number of vehicles is crucial to the success of the safety message transmission scheme. Therefore, a propagation model is formulated to include the effect of the environmental conditions. The propagation modeling involves two important aspects, namely, large-scale path loss and small-scale fading. Large-scale path loss or path loss is used for predicting the mean signal strength at a particular distance

from a sender, while the small-scale fading generally involves the detailed modeling of multi-path fading statistics, power delay profile, and Doppler spectrum. We use $p_r(d)$ to denote the probability for a receiver to successfully detect a message transmitted by a sender at a distance d . Then, $p_r(d)$ can be expressed by

$$p_r(d) = Prob(pow_r(d) > pow_{th}) \quad (1)$$

where $pow_r(d)$ and pow_{th} denote the received power of the message transmitted at a distance d and the power reception threshold, above which the message can be detected, respectively. Using Nakagami fading model [18], which is proved in the empirical study of VANETs to accurately model the channel with fading, we can derive the Probability Density Function (PDF) of $pow_r(d)$ by

$$f_{pow_r(d)}(x) = \left(\frac{m}{\Omega(d)}\right)^m \cdot \frac{x^{m-1}}{\Gamma(m)} \cdot e^{-\frac{mx}{\Omega(d)}}, \quad (2)$$

where m and $\Omega(d)$ denote the fading parameter and the average received power, respectively. From (2), the corresponding Cumulative Distribution Function (CDF) can be derived by

$$F_{pow_r(d)}(x) = \left(\frac{m}{\Omega(d)}\right)^m \frac{1}{\Gamma(m)} \int_0^x u^{m-1} e^{-\frac{mu}{\Omega(d)}} du. \quad (3)$$

Then from (1), (3), we can derive $p_r(d)$ by

$$\begin{aligned} p_r(d) &= Prob(pow_r(d) > pow_{th}) \\ &= 1 - F_{pow_r(d)}(pow_{th}) \\ &= 1 - \left(\frac{m}{\Omega(d)}\right)^m \frac{1}{\Gamma(m)} \int_0^{pow_{th}} u^{m-1} e^{-\frac{mu}{\Omega(d)}} du. \end{aligned} \quad (4)$$

The path loss can be expressed as follows:

$$\frac{\Omega(d_0)}{\Omega(d_1)} = \left(\frac{d_1}{d_0}\right)^\gamma, \quad (5)$$

where $\Omega(d_0)$ and $\Omega(d_1)$ are the mean received power of a message transmitted by a sender at a distance d_0 and d_1 , respectively; γ is the path loss exponent. Since a receiver should be able to detect a message's signal at a distance equal to the sender's transmission range R [19], we have

$$\frac{pow_{th}}{\Omega(d)} = \left(\frac{d}{R}\right)^\gamma, \quad (6)$$

Thus, using (4) and (6), we have

$$p_r(d) = 1 - \frac{(md^\gamma)^m}{\Gamma(m)} \int_0^{1/R^\gamma} u^{m-1} e^{-mud^\gamma} du. \quad (7)$$

Due to the randomness of vehicle positions within the RSU coverage, p_r can be derived by

$$p_r = \frac{1}{R} \int_0^R p_r(d) dd. \quad (8)$$

2) VEHICLE ESTIMATION

In this procedure, we estimate the number of unidentified vehicles at the start of current SFMI, i.e., SFMI_{*i*}, which is denoted by *n*. During the CCMTP of SFMI_{*i*}, the RSU transmits a CCM, which includes the length information of FSFP_{*i*} and TSCP_{*i*}, i.e., the FSFP and TSCP of SFMI_{*i*}. After the RSU transmits the CCM, the vehicles will successfully detect this message with probability *p_r*. Since during a CCMTP, only the RSU is allowed for transmission, the number of vehicles *n_r* that successfully receive the CCM among these *n* vehicles can be derived by

$$n_r = n \cdot p_r, \quad (9)$$

The vehicles that successfully receive the CCM randomly access a time slot of TSCP_{*i*} to transmit safety messages. Let *l_{tscp,i}* denote the number of time slots of TSCP_{*i*}. Note that the vehicles that fail to receive the CCM are unaware of the existence of the RSU. Thus these vehicles do nothing until successfully receiving another CCM.

Theorem 1: Taking account of the propagation loss, the expected number of success slots, \tilde{n}_s , perceived by the RSU at the end of an SFMI, where a success slot is a slot on which a safety message transmitted by a vehicle is successfully received by the RSU and so the vehicle can be identified by the RSU, is $\tilde{n}_s = p_r \cdot n_r \cdot (1 - \frac{p_r}{l_{tscp}})^{n_r-1}$, where *l_{tscp}* is the number of time slots of TSCP.

Proof: Let *n_i*, *n_s*, *n_c* denote the expected number of idle, single, and collision slots, respectively. Here, an idle slot is a slot during which no vehicle transmits safety message; a single slot is a slot during which only one vehicle transmits safety message; a collision slot is a slot during which more than one vehicle simultaneously transmit safety messages. According to the binomial distribution, *n_i*, *n_s*, *n_c* can be derived by following:

$$\begin{cases} n_i = (1 - \frac{1}{l_{tscp}})^{n_r} \cdot l_{tscp}, \\ n_s = n_r \cdot (1 - \frac{1}{l_{tscp}})^{n_r-1}, \\ n_c = l_{tscp} - n_i - n_s. \end{cases} \quad (10)$$

Let *c_v* ($2 \leq v \leq n_r$) denote a collision slot, at which *v* vehicles simultaneously transmit safety messages. Due to the propagation loss of messages, when *v* - 1 messages are lost at slot *c_v* with probability *p_v*, it is possible for the RSU to detect only one of the messages. The probability of *c_v*, i.e., *Prob(c_v)*, can be derived by

$$Prob(c_v) = C_v^{n_r} \cdot \left(\frac{1}{l_{tscp}}\right)^v \cdot \left(1 - \frac{1}{l_{tscp}}\right)^{n_r-v}. \quad (11)$$

Also, we can derive *p_v* by

$$p_v = v \cdot p_r \cdot (1 - p_r)^{v-1}. \quad (12)$$

Hence, we can derive the number of success time slots, \tilde{n}_s , as follows:

$$\tilde{n}_s = n_s \cdot p_r + l_{tscp} \cdot \sum_{v=2}^{n_r} p_v \cdot Prob(c_v). \quad (13)$$

Substituting (10)–(12) into (13), we have

$$\begin{cases} \tilde{n}_s = p_r \cdot C_1^{n_r} \cdot 1 \cdot \left(\frac{1}{l_{tscp}}\right)^0 \cdot (1 - p_r)^0 \cdot \left(1 - \frac{1}{l_{tscp}}\right)^{n_r-1} \\ \quad + p_r \cdot C_2^{n_r} \cdot 2 \cdot \left(\frac{1}{l_{tscp}}\right)^1 \cdot (1 - p_r)^1 \cdot \left(1 - \frac{1}{l_{tscp}}\right)^{n_r-2} \\ \quad + p_r \cdot C_3^{n_r} \cdot 3 \cdot \left(\frac{1}{l_{tscp}}\right)^2 \cdot (1 - p_r)^2 \cdot \left(1 - \frac{1}{l_{tscp}}\right)^{n_r-3} \\ \quad \vdots \\ \quad + p_r \cdot C_{n_r}^{n_r} \cdot n_r \cdot \left(\frac{1}{l_{tscp}}\right)^{n_r} \cdot (1 - p_r)^{n_r} \cdot \left(1 - \frac{1}{l_{tscp}}\right)^0. \end{cases} \quad (14)$$

We know that

$$\begin{cases} C_1^{n_r} \cdot 1 = n_r \cdot C_0^{n_r-1}, \\ C_2^{n_r} \cdot 2 = n_r \cdot C_1^{n_r-1}, \\ C_3^{n_r} \cdot 3 = n_r \cdot C_2^{n_r-1}, \\ \vdots \\ C_{n_r}^{n_r} \cdot n_r = n_r \cdot C_{n_r-1}^{n_r-1}. \end{cases} \quad (15)$$

Therefore, (14) can be replaced as follows:

$$\begin{cases} \tilde{n}_s = p_r \cdot n_r \cdot \sum_{i=0}^{n_r-1} C_i^{n_r-1} \cdot \left[\frac{1}{l_{tscp}} \cdot (1 - p_r)\right]^i \\ \quad \cdot \left(1 - \frac{1}{l_{tscp}}\right)^{n_r-1-i} \\ = p_r \cdot n_r \cdot \left(\frac{1}{l_{tscp}} - \frac{p_r}{l_{tscp}} + 1 - \frac{1}{l_{tscp}}\right)^{n_r-1} \\ = p_r \cdot n_r \cdot \left(1 - \frac{p_r}{l_{tscp}}\right)^{n_r-1} \end{cases} \quad (16)$$

The theorem gets proved. ■

Therefore, from (16), *n_r*, i.e., the number of vehicles receiving the CCM among the *n* vehicles that were not identified at the start of SFMI_{*i*} can be expressed by

$$n_r = \frac{\tilde{n}_s}{p_r \cdot \left(1 - \frac{p_r}{l_{tscp,i}}\right)^{n_r-1}}. \quad (17)$$

Since the values of *p_r* and *l_{tscp,i}* are known by the RSU, and the value of \tilde{n}_s is observable at the end of SFMI_{*i*}, the value of *n_r* can be derived using (17). A fixed-point iteration algorithm is utilized to achieve the value of *n_r*. The pseudo-code is outlined as Algorithm 1.

Algorithm 1 Derivation of *n_r*

```
//Initialization
nr = ∞
nr_new = 0
ε = 0.000001
while abs(nr_new - nr) > ε do
    nr = nr_new
    Use Equation (17) to calculate nr_new
end while
```

As a result, from (9), the value of *n* can be achieved at the end of SFMI_{*i*}.

3) VEHICLE PREDICTION PROCEDURE

In this procedure, we predict the number of vehicles to be identified during SFMI_{i+1}. Let n_{ne} denote the number of vehicles that have newly entered the RSU coverage during SFMI_i, which can be derived by

$$n_{ne} = l_{sfmi_i} \cdot t_{slot} \cdot v_{ave} \cdot ds_{ave}, \quad (18)$$

where l_{sfmi_i} , t_{slot} , v_{ave} , and ds_{ave} denote the number of time slots in SFMI_i, the duration of a time slot, the average vehicle velocity and density, respectively. The value of l_{sfmi_i} is known by the RSU. For the duration of a time slot, denoted by t_{slot} , a 260-byte safety message takes nearly 0.35 ms at a 6-Mbps data rate, which is justified to be the best data rate choice for VANETs [20]; hence, a time slot duration could use this value. The RSU can derive the average vehicle velocity and density from the received safety messages. Therefore, the value of n_{ne} can be derived by the RSU.

The RSU determines whether a vehicle will leave its coverage during subsequent SFMI, i.e., SFMI_{i+1}, using its position and velocity information retrieved from its safety messages. If the residual time before a vehicle will cross the boundary of the RSU coverage ends before the arrival of the allocated time slot, the vehicle will be considered to be a leaving vehicle and excluded in the next CCM. Then, the predicted number of vehicles \ddot{n} that need to be identified during SFMI_{i+1} can be derived as follows:

$$\ddot{n} = n + n_{ne} - \tilde{n}_s - n_{lv}, \quad (19)$$

where n_{lv} denotes the number of leaving vehicles during the subsequent SFMI. Note that since \tilde{n}_s vehicles have been identified during SFMI_i, there is no need to identify these vehicles during SFMI_{i+1} so that they should be excluded.

4) TSCP OPTIMIZATION PROCEDURE

According to (16), the safety message throughput θ for TSCP_{i+1} can be derived by

$$\theta = \ddot{n} \cdot p_r^2 \cdot \frac{1}{l_{tscp_i+1}} \cdot \left(1 - \frac{p_r}{l_{tscp_i+1}}\right)^{\ddot{n} \cdot p_r - 1}, \quad (20)$$

where l_{tscp_i+1} denotes the number of time slots in TSCP_{i+1}. In order to maximize the expected number of successfully identified vehicles with the minimum required identification duration (i.e., TSCP), the throughput should be maximized. Taking derivative of (20) with respect to l_{tscp_i+1} , and equating it to 0, we obtain, after some simplifications, the following equation:

$$l_{tscp_i+1} = \ddot{n} \cdot p_r^2. \quad (21)$$

Therefore, the length of TSCP_{i+1} is optimized by (21).

5) TIME SLOT ALLOCATION PROCEDURE

The vehicles that are successfully identified will be allocated a time slot of FSFP in subsequent SFMI. The information of identified vehicles and the corresponding allocated time slots is inserted into the CCM that will be transmitted during subsequent CCMTP.

B. SERVICE MESSAGE TRANSMISSION

The SCM transmitted during the SCMTP includes the information of IDs of identified vehicles so far, initial CW size, and length of SRP and STP (see Fig. 3). During SRP, the vehicles indicated in the SCM, i.e., the vehicles that have been identified so far on the CCH, contend to transmit RQMs on SCH_1, i.e., Channel 172 (see Fig. 3) based on the IEEE 802.11 DCF [7], using the indicated initial CW for SCH reservations. If an RQM is successfully received, the RSU sends back an RTM to the sending vehicle. The RTM includes the ID and time interval of SCH on which the service message will be transmitted by the vehicle. Like [17], the following assumptions are made: (i) the size of a service message transmitted during STP is constant so that the durations for service message transmissions are the same; (ii) each vehicle can only transmit one service message for each successful channel reservation; (iii) every vehicle always has RQMs available after a successful reservation, i.e., saturated traffic condition. The SCH allocation follows the round-robin manner: the first successful reservation will be allocated SCH_1 and the second reservation will be allocated SCH_2 and so forth. If all the SCHs are allocated, a new round begins. During the STP, the vehicles that have made service reservations, based on the information indicated in the RTM, switch to the corresponding SCHs to transmit service messages in the specified time intervals.

The notations used in the service message transmission scheme are listed in Table 2. Also, the right part of Fig. 4 expresses the flow diagram of the scheme, which is invoked at the start of each SVMI, including three procedures: (i) derivation of each vehicle's behavior: taking account of the real world environmental conditions and the number of identified vehicles, a Markov chain model is applied to examine the behavior of a single vehicle and derive the stationary probability for a vehicle to transmit an RQM in each backoff slot² (ii) optimizing the ratio of SRP length to STP length: using the result from the Markov chain, the average time taken for a successful SCH reservation is derived. Then, the optimal ratio of the length of SRP to the length of STP is achieved. Note that our proposed Markov model is different from that in [17], since our model takes account of finite retransmission limit and the propagation loss, which make the model more realistic and the ratio optimization more accurate; (iii) optimizing the initial CW size: with the derived optimal ratio, the initial CW size is adaptively optimized to maximize the number of successful SCH reservations, thereby maximizing the SCH throughput.

1) DERIVATION OF VEHICLE'S BEHAVIOR PROCEDURE

A 2-D Markov chain model is proposed to derive the stationary probability τ that a vehicle transmits an RQM in an arbitrary backoff slot. We use k to denote the number of vehicles that have been identified at the start of an SVMI. We use $X(t)$ to denote the state of a given vehicle at backoff

²Note that the *backoff slot* refers to the slot in DCF mechanism [7].

TABLE 2. Notations for service message transmission scheme.

Notation	Description
SVMI	Time interval for SCH reservation and service message transmissions and includes SCMTP, SRP, STP
SCMTP	Time period for SCM transmission
SRP	Time period for RQM transmission
STP	Time period for service message transmission
SCM	Management message of SVMI
RQM	Request message for SCH reservation
RTM	Response message to RQM
k	The number of identified vehicles at the start of an SVMI
τ	Transmission probability of an RQM
p_{fail}	Failure probability of an RQM transmission
p_s	Probability of a success backoff slot
p_f	Probability of a failure backoff slot
p_i	Probability of an idle backoff slot
T_s	Duration of a success backoff slot
T_f	Duration of a failure backoff slot
T_i	Duration of an idle backoff slot
l_{srp}	SRP length
l_{stp}	STP length
l_{svmi}	SVMI length
δ	Optimal ratio between l_{srp} and l_{stp}
D	Service message payload
χ	Service message throughput
φ	Service message delay

slot t . We can express $X(t)$ as follows:

$$X(t) = (s, w),$$

where s and w represent backoff stage and backoff counter of head of line (HOL) message, respectively. The initial value of w is uniformly drawn from $[0, W_s - 1]$, where W_s is the backoff window size at backoff stage s and can be derived by $CW_s + 1$, where CW_s is the CW size at backoff stage s . The value of w will be decremented by 1 at the end of each backoff slot. The HOL message will be transmitted when w reaches 0. The value of s is initialized to 0 for each message and incremented by 1 after each transmission failure. If the message transmission fails when the value of s reaches h , the message will be discarded and s will be reset to 0 for the next message. Also, once the transmission is successful, s will be reset to 0. Then, the bidimensional process (s, w) can be modeled with a discrete-time 2-D Markov chain, as shown in Fig. 6. We denote the stationary probability distribution of the Markov chain as follows:

For $0 \leq s \leq h$ and $0 \leq w \leq W_s - 1$,

$$\pi_{s,w} \triangleq \lim_{t \rightarrow \infty} Prob(X(t) = (s, w)). \quad (22)$$

Theorem 2: The stationary probability τ that a vehicle transmits an RQM in an arbitrary backoff slot is $\tau = \frac{1 - (p_{fail})^{h+1}}{1 - p_{fail}} \pi_{0,0}$, and the probability of transmission failure is $p_{fail} = 1 - p_r(1 - \tau p_r)^{k-1}$.

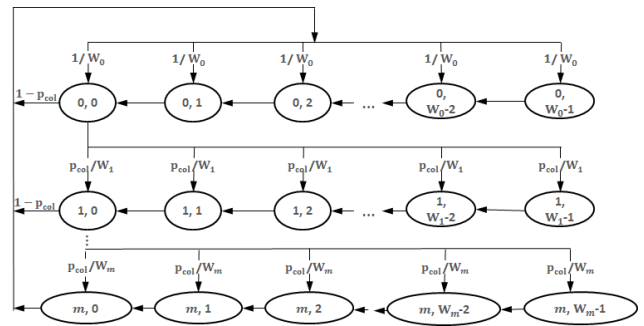

FIGURE 6. Markov chain model.

Proof: For the sake of simplification, we define

$$p(x|y) \triangleq Prob(X(t + 1) = x | X(t) = y).$$

From the Markov chain given in Fig. 6, the one-step transition probabilities can be given as follows:

For $0 \leq s < h$,

$$p(0, w|s, 0) = (1 - p_{fail})/W_0 \quad 0 \leq w \leq W_0 - 1, \quad (23)$$

$$p(s + 1, w|s, 0) = p_{fail}/W_{s+1} \quad 0 \leq w \leq W_{s+1} - 1. \quad (24)$$

for $s = h$,

$$p(0, w|m, 0) = 1/W_0 \quad 0 \leq w \leq W_0 - 1. \quad (25)$$

In order to represent backoff counter decrement, for $0 \leq s \leq h$,

$$p(s, w - 1|s, w) = 1 \quad 1 \leq w \leq W_s - 1. \quad (26)$$

where each equation implies as follows:

- Equation (23) accounts for the fact that before the retransmission limit is reached, if HOL message is successfully transmitted, a new backoff procedure is initiated.
- Equation (24) stands for the case that before the retransmission limit is reached, if it fails to transmit HOL message, the message is retransmitted at the next backoff stage.
- Equation (25) accounts for the fact that when the retransmission limit is reached, a new backoff procedure starts for a new message, regardless of the transmission result.
- Equation (26) corresponds to the case that the backoff counter decreases by one at the end of a backoff slot.

The CW size at backoff stage s can be expressed as follows:

$$CW_s = \begin{cases} CW_{min} & s = 0, \\ 2CW_{s-1} + 1 & 1 \leq s \leq h, \end{cases} \quad (27)$$

from which we can express the backoff window size by

$$W_s = \begin{cases} CW_{min} + 1 & s = 0, \\ 2^s \cdot W_0 & 1 \leq s \leq h. \end{cases} \quad (28)$$

In addition, according to the normalizing equation [21], we have

$$1 = \sum_{s=0}^h \sum_{w=0}^{W_s-1} \pi_{s,w}. \quad (29)$$

From (23)–(29), we can express $\pi_{0,0}$ by

$$\pi_{0,0} = \left[\frac{1}{2} \left(\frac{1 - (p_{fail})^{h+1}}{1 - p_{fail}} + \frac{1 - (2p_{fail})^{h+1}}{1 - 2p_{fail}} W_0 \right) \right]^{-1}. \quad (30)$$

Since an RQM is transmitted when the backoff counter is 0, the probability τ that a vehicle transmits an RQM in an arbitrary backoff slot can be derived by

$$\tau = \sum_{i=0}^h \pi_{i,0}. \quad (31)$$

From the Markov chain, we have

$$\tau = \frac{1 - (p_{fail})^{h+1}}{1 - p_{fail}} \pi_{0,0}. \quad (32)$$

An RQM can be successfully received by the RSU if and only if one of the following conditions is satisfied: (i) a message transmitted by a vehicle is successfully detected by the RSU, i.e., the received power of the message is higher than the power reception threshold, meanwhile no other vehicles transmit simultaneously; (ii) a message is successfully detected by the RSU, meanwhile the messages transmitted by other vehicles are lost due to the propagation loss, i.e., the powers of the messages are lower than the power reception threshold. We denote by p_{suc} , the probability for a vehicle to successfully transmit an RQM, which can be derived by

$$\begin{aligned} p_{suc} &= p_r(1 - \tau)^{k-1} + p_r \sum_{i=1}^{k-1} C_i^{k-1} \tau^i (1 - \tau)^{k-1-i} (1 - p_r)^i \\ &= p_r \sum_{i=0}^{k-1} C_i^{k-1} [\tau(1 - p_r)]^i (1 - \tau)^{k-1-i} \\ &= p_r(1 - \tau p_r)^{k-1}. \end{aligned} \quad (33)$$

Hence, we can derive p_{fail} as follows:

$$p_{fail} = 1 - p_{suc} = 1 - p_r(1 - \tau p_r)^{k-1}. \quad (34)$$

The theorem gets proved. ■

To this end, using (30)–(34), the value of τ can be derived.

2) OPTIMIZING THE RATIO OF SRP TO STP

In each backoff slot during SRP, the probability for the RSU to successfully receive a channel reservation request is denoted by p_s ; the probability of observing a failure and an idle channel is denoted by p_f and p_i , respectively. Then, we have

$$\begin{cases} p_s = C_1^k p_r \tau (1 - \tau)^{k-1} + \sum_{i=2}^k C_i^k \tau^i (1 - \tau)^{k-i} \\ \quad \cdot C_1^i p_r (1 - p_r)^{i-1}, \\ p_f = 1 - p_s - p_i, \\ p_i = (1 - \tau)^k + \sum_{i=1}^k C_i^k \tau^i (1 - \tau)^{k-i} (1 - p_r)^i. \end{cases} \quad (35)$$

Using the similar approach of (17), (35) can be simplified as follows:

$$\begin{cases} p_s = k p_r \tau (1 - \tau p_r)^{k-1}, \\ p_f = 1 - k p_r \tau (1 - \tau p_r)^{k-1} - (1 - p_r \tau)^k, \\ p_i = (1 - p_r \tau)^k. \end{cases} \quad (36)$$

Let T_s , T_f , and T_i denote the duration of a success, a failure, and an idle backoff slot, respectively. Then, we have

$$\begin{cases} T_s = T_{rqm} + T_{sifs} + T_{rtm} + T_{difs}, \\ T_f = T_{rqm} + T_{difs}, \\ T_i = T_{slot}, \end{cases} \quad (37)$$

where T_{rqm} and T_{rtm} denote the time for transmitting RQM and RTM, respectively; T_{sifs} , T_{difs} , and T_{slot} denote the duration of SIFS, DIFS, and idle slot, respectively [7]. The average length of a backoff slot, denoted by T_{ave} , can be derived by

$$T_{ave} = p_s \cdot T_s + p_f \cdot T_f + p_i \cdot T_i. \quad (38)$$

The probability that a successful reservation occurs at i th slot, counting from the last successful reservation can be derived by

$$Prob(I = i) = (1 - p_s)^{i-1} \cdot p_s. \quad (39)$$

According to the property of geometric distribution, the average number of slots between two successive successful reservations is $1/p_s$ [22]. Hence, the average duration for a successful SCH reservation, i.e., $E[T_{res}]$, can be derived by

$$E[T_{res}] = \frac{p_s}{p_s} \cdot T_s + \frac{p_f}{p_s} \cdot T_f + \frac{p_i}{p_s} \cdot T_i. \quad (40)$$

The optimal ratio δ of the length of SRP to the length of STP is achieved if the number of SCH reservations made during SRP is equal to the number of service messages that will be transmitted during the STP. Therefore, we can derive δ as follows:

$$\delta = \frac{E[T_{res}]}{E[T_{ser}]} \cdot 6, \quad (41)$$

where $E[T_{ser}]$ denotes the time for a service message to be transmitted. Note that the size of service messages transmitted during the STP is assumed to be constant so that the durations for service message transmissions are the same. $E[T_{ser}]$ can be derived as follows:

$$E[T_{ser}] = T_{data} + T_{sifs}, \quad (42)$$

where T_{data} denotes the time needed to transmit a service message.

3) OPTIMIZING INITIAL CW SIZE PROCEDURE

The length of SRP and STP, denoted by l_{srp} and l_{stp} , respectively, can be derived by

$$\begin{cases} l_{srp} = \frac{\delta}{\delta + 1} \cdot l_{svmi}, \\ l_{stp} = \frac{1}{\delta + 1} \cdot l_{svmi}, \end{cases} \quad (43)$$

Algorithm 2 Derivation of Q

```

//Initialization
 $Q = \infty$ 
 $Q_{new} = 0$ 
 $\epsilon = 0.000001$ 
while  $\text{abs}(Q_{new} - Q) > \epsilon$  do
   $Q = Q_{new}$ 
  Use Equation (47) to calculate  $Q_{new}$ 
end while

```

where l_{svmi} denotes the length of SVMl. Note that l_{svmi} is fixed, and set to be 100 ms in order to set a limit for the transmission delay of service message [8]. Hence, the service message throughput χ , can be derived as follows:

$$\chi = \frac{l_{stp}}{l_{svmi} \cdot E[T_{ser}]} \cdot D \cdot 6, \quad (44)$$

where D is the payload of the service message. From (41), (43), (44), we have

$$\chi = \frac{6D}{6 \cdot E[T_{res}] + E[T_{ser}]}. \quad (45)$$

In (45), in order to maximize χ , $E[T_{res}]$ should be minimized, since $E[T_{ser}]$ and D are fixed values. We can express $E[T_{res}]$ as follows:

$$E[T_{res}] = \frac{T_i \cdot (1 - p_r \tau)}{k \cdot p_r \cdot \tau} + \frac{T_c}{k \cdot p_r \cdot \tau (1 - p_r \tau)^{k-1}} - \frac{T_c \cdot (1 - \tau p_r)}{k \cdot p_r \cdot \tau} + T_s - T_c. \quad (46)$$

In order to minimize $E[T_{res}]$, taking derivative of (46) with respect to τ , and imposing it equal to 0, after some simplifications, we derive Equation (47) shown at the bottom of this page, where $Q = \tau \cdot p_r$. A fixed-point iteration algorithm is utilized to obtain the value of Q as outlined in Algorithm 2.

Then, we can derive the optimal transmission probability $\tilde{\tau}$, i.e., $\tilde{\tau} = Q/p_r$. From (30), (32), and (34), we can express W_0 as follows:

$$W_0 = \frac{1 - 2p_{fail}}{1 - (2p_{fail})^{h+1}} \left[\left(\frac{2}{\tilde{\tau}} - 1 \right) \cdot \frac{1 - (p_{fail})^{h+1}}{1 - p_{fail}} \right]. \quad (48)$$

In (34), setting the value of τ as $\tilde{\tau}$, the value of \tilde{p}_{fail} can be derived. Then, setting the value of p_{fail} and τ in (48) to \tilde{p}_{fail} and $\tilde{\tau}$ respectively, the optimal initial CW, which is $\tilde{W}_0 + 1$, can be derived.

Now, we show the analytical model for service message delay. The service message delay, denoted by φ , is defined as the time duration from the moment that a vehicle contends for transmitting an RQM to the corresponding service message transmission completion point. If a vehicle fails to reserve an SCH during an SRP due to a large channel access delay,

it needs to wait for subsequent SRPs to retry until successfully transmits an RQM after several SVMIs. The channel access delay, denoted by B , is the duration from the moment a vehicle starts to contend for transmitting an RQM to the time the RQM is successfully transmitted. As a result, the service message delay consists of three parts, namely, delay in SRP, delay in STP, and multiple SVMIs due to multiple retries. The delays in SRP and STP could be approximated to half of each interval length due to the randomness of channel reservation and service message transmission. Then, it is obvious that the main part of service message delay is the sum of multiple SVMIs, since it is relatively large compared to the others.

We first derive the Probability Generating Function (PGF) of the backoff delay spent in s th backoff stage, which is denoted by B_s . For the sake of simplicity, the metrics related to the delay in this section are presented in the unit of an idle backoff slot T_i unless otherwise mentioned. Since the backoff counter is uniformly drawn from $[0, W_s - 1]$, the PGF of B_s can be derived by

$$E[z^{B_s}] = \frac{1}{W_s} \left\{ z^0 + \sum_{i=1}^{W_s-1} (p_i \cdot z + p_s \cdot z^{\hat{T}_s} + p_c \cdot z^{\hat{T}_c})^i \right\}, \quad (49)$$

where \hat{T}_s and \hat{T}_c can be expressed by

$$\begin{cases} \hat{T}_s = T_s/T_i, \\ \hat{T}_c = T_c/T_i. \end{cases} \quad (50)$$

Hence, B can be expressed by

$$B = \sum_{s=0}^j (B_s + T_{tr}) \text{w.p.} (p_{fail})^j (1 - p_{fail}), \quad (51)$$

where $0 \leq j \leq h$. T_{tr} is the RQM transmission time, which can be derived by

$$T_{tr} = \frac{1}{T_i} (p_{fail} \cdot T_f + (1 - p_{fail}) \cdot T_s). \quad (52)$$

Through (49)–(52), we can derive the Probability Mass Function (PMF) of B . Let p_{res} denote the probability for a vehicle to successfully make at least one SCH reservation during an SRP, which can be derived as follows:

$$p_{res} = \text{Prob}(B \leq l_{srp}/T_i). \quad (53)$$

According to the property of geometric distribution, the average number of SVMIs elapsed until a successful SCH reservation is $1/p_{res} - 1$ [22]. Hence, φ can be expressed by

$$\varphi = \left(\frac{1}{p_{res}} - 1 \right) \cdot l_{svmi} + \frac{l_{srp}}{2} + \frac{l_{stp}}{2}. \quad (54)$$

$$Q = \frac{[T_i(1-Q)^k - T_c(1-Q)^k + T_c] \cdot [1-Q(k-1)(1-Q)^{-1}]}{k(T_c - T_i)(1-Q)^{k-1}} \quad (47)$$

C. OVERHEAD ANALYSIS

The CCM and SCM, which are transmitted once in each SFMI and SVMI respectively, are the only coordination overhead in VCAR-MAC. The main part of a CCM is the IDs of vehicles within the RSU coverage and the time slot allocated to each of these vehicles. Since the maximum number of time slots included in an SFMI is $100\text{ ms}/0.35\text{ ms} \approx 286$, the maximum number of vehicles that can be allocated a time slot is also 286. Hence, at most $\lceil \log_2 286 \rceil$ bits are required to represent a vehicle ID, where $\lceil \cdot \rceil$ denotes the ceiling function. Similarly, $\lceil \log_2 286 \rceil$ bits are sufficient to identify a time slot. Therefore, the size of a CCM is about $286 \cdot 2 \cdot \lceil \log_2 286 \rceil \approx 644$ bytes. Similarly, the main part of an SCM is the IDs of identified vehicles. Hence, the size of an SCM is around $286 \cdot \lceil \log_2 286 \rceil \approx 322$ bytes.

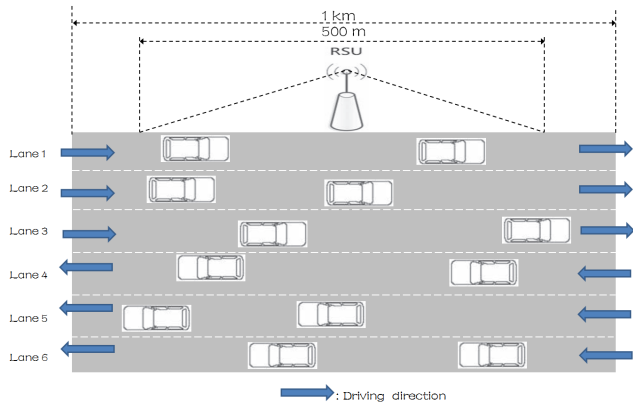

FIGURE 7. 6-lane highway scenario with an RSU and moving vehicles.

IV. PERFORMANCE EVALUATION

In this section, we evaluate the performance of our proposed VCAR-MAC, using an event-driven simulation program written in MATLAB and SUMO [23]. We employ Krauss-car-following model, which is the default vehicle mobility model provided in SUMO, with a maximum speed of 30 m/s for each vehicle. The simulated scenario is a segment of a 6-lane, two-direction highway, with an RSU located at the middle point of the highway segment, as shown in Fig. 7. For the duration of an SFMI slot, a 260-byte safety message takes nearly 0.35 ms, at a 6-Mb/s data rate. The maximum length of SFMI is limited to 100 ms to meet the safety message delay requirement [4]. Hence, with 0.35-ms time slot, the maximum number of time slots in an SFMI is $100\text{ ms}/0.35\text{ ms} = 286$. The simulation time is set to 1000 s. In order to achieve a confidence interval of 0.95 with half-widths of less than 5% about the mean, we ran 100 simulations with different random seeds and averaged the results. Table 3 shows the parameters used in the simulation.

In order to investigate how fast the TDMA-based safety message transmission scheme in VCAR-MAC can identify vehicles, we show the average number of identified vehicles along the time axis, as shown in Fig. 8. Initially, SFMI has

TABLE 3. Simulation parameters.

Parameter	Value
Channel bandwidth	10 MHz
Transmission power	25 dBm
Fading parameter (m)	2
Path loss exponent (γ)	2
Data rate	6 Mbps
RSU coverage (R)	500 m
Highway segment length	1 km
Highway direction	two-direction
Maximum vehicle velocity	30 m/s
Number of lanes	6
Safety message size	260 bytes
Service message size	1000 bytes
RQM/RTM size	60/72 bytes
Maximum backoff stage (h)	5
Idle backoff slot duration (T_i)	13 μ s
SIFS/DIFS duration (T_{sifs}/T_{difs})	32/58 μ s
Initial number of time slots in SFMI	125
Maximum SFMI length	100 ms
SVMi length	100 ms
Safety message arrival rate in WAVE-DR and CR-MAC	10 messages/s
SCH reservation message arrival rate in WAVE-DR and CR-MAC	saturated
Initial safety message CW size in WAVE-DR and CR-MAC	16
Initial SCH reservation message CW size in WAVE-DR and CR-MAC	32
Ack message size in WAVE-DR and CR-MAC	48 bytes

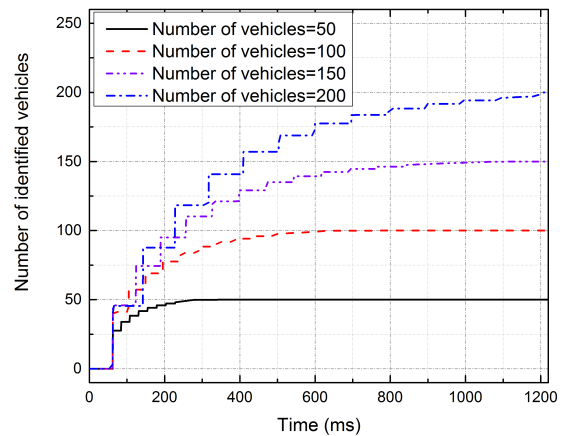

FIGURE 8. The number of identified vehicles along time axis.

125 time slots and no vehicles are identified such that every vehicle randomly chooses a time slot to transmit safety message. From the figure, we can observe that the number of identified vehicles increases with time. In Fig. 9, we show the vehicle identification delay, i.e., the time duration needed to identify all the vehicles within the RSU coverage. It can be observed that even when the number of vehicles within RSU coverage is as large as 200 vehicles, it only takes approximately 1.3 s to identify all the vehicles.

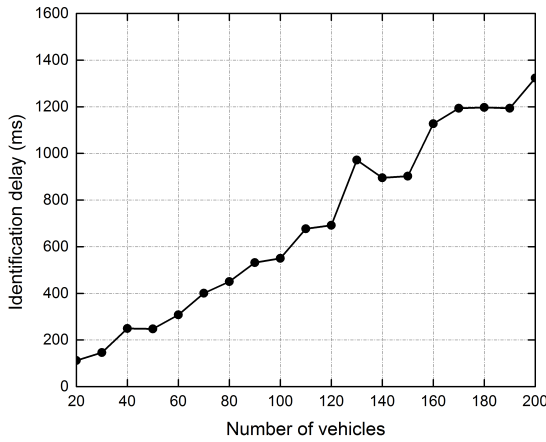

FIGURE 9. The vehicle identification delay.

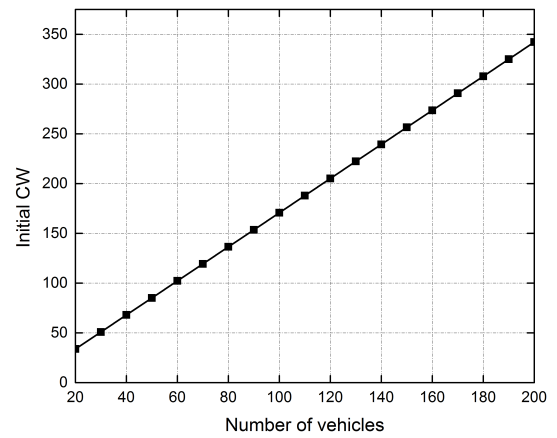

FIGURE 11. The optimal initial CW size.

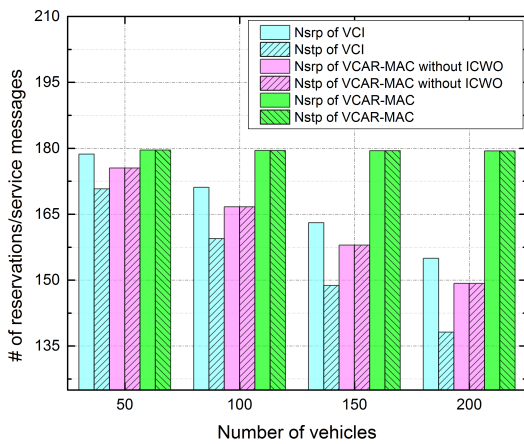

FIGURE 10. The number of channel reservations and the number of transmitted service messages.

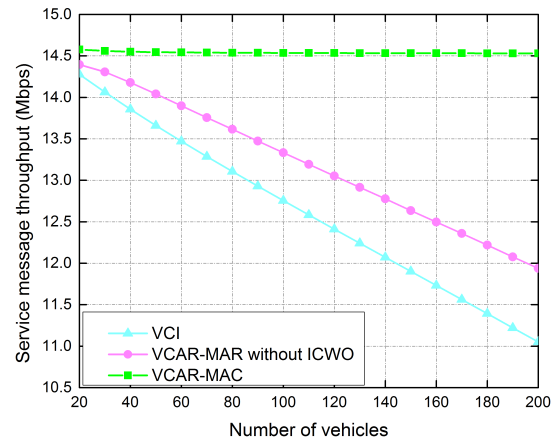

FIGURE 12. The service message throughput.

Fig. 10 shows the number of SCH reservations made during SRP and the number of service messages transmitted during STP, denoted by N_{srp} and N_{stp} , respectively, in terms of the average number of vehicles within the RSU coverage. We compare the performance of multi-SCH coordination scheme in VCAR-MAC with VCI algorithm [17] and VCAR-MAC without initial CW size optimization (VCAR-MAC without ICWO) in order to show the accuracy in optimizing the ratio of l_{srp} to l_{stp} and the effect of initial CW size optimization, respectively. Since VCI uses a single-radio device, for fairness, we assume that in VCI, each vehicle uses a dual-radio device, with one radio operating on CCH for safety message transmission, while the other one operating on SCHs for service message transmission. Note that since we aim to compare multi-SCH coordination schemes between VCAR-MAC and VCI, we only investigate the performances on SCHs. The initial CW size of RQM is set to 32. From the figure, it can be observed that both VCAR-MAC without ICWO and VCAR-MAC show perfect match between N_{srp} and N_{stp} , while VCI shows a mismatch. This is because VCI ignores the effect of environmental conditions in deriving

the message transmission probability and the expected duration between two successive successful SCH reservations, resulting in an inaccurate optimal ratio of l_{srp} to l_{stp} . Also, it can be observed that, the initial CW size optimization can boost the number of SCH reservations to the maximum level. Fig. 11 shows the optimal initial CW size in terms of the average number of vehicles within the RSU coverage. It can be observed that the optimal initial CW size increases as the number of vehicles increases, and is much larger than the initial CW size defined in the WAVE [7].

Fig. 12 shows the throughput in terms of the average number of vehicles within the RSU coverage. It can be observed that VCAR-MAC has the best performance. This is because in VCI algorithm, the mismatch between N_{srp} and N_{stp} results in either the channel shortage or wastage problem. The channel shortage problem occurs when N_{srp} is larger than N_{stp} so that service message transmission period is unable to accommodate all the reservations. On the other hand, the channel wastage problem occurs when N_{srp} is less than N_{stp} so that the bandwidth of service channel transmission period is wasted although all the reservations are satisfied. Further, we can

observe that VCAR-MAC outperforms VCAR-MAC without ICWO, due to the reason that the optimal initial CW maximizes the number of successful SCH reservations, thereby maximizing the service message throughput.

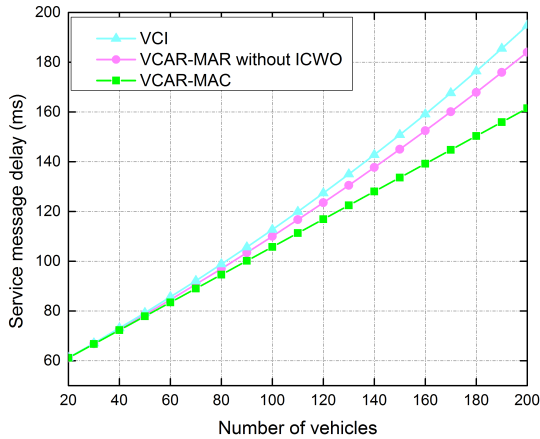

FIGURE 13. The service message delay.

Fig. 13 shows the service message delay performance. The delay increases with the number of vehicles due to the increase of channel access contention. It can be observed that VCAR-MAC has the best performance. This is because VCAR-MAC allows the largest number of SCH reservations per SRP, which increases the probability for a vehicle to reserve an SCH before an SRP ends.

In order to compare VCAR-MAC with other scheme that also uses a dual-radio device for safety and service message transmissions, another set of experiments is conducted for performance comparison with CR-MAC [12] and WAVE with dual-radio (WAVE-DR) [24]. We use MATLAB and SUMO to simulate CR-MAC and WAVE-DR schemes. According to [24], in WAVE-DR, one radio is responsible for safety message transmission while the other radio is for service message transmission following IEEE 1609.4. Therefore, we assume that CCH and channel 172 are used for safety message transmission and SCH reservation message transmission, respectively, and all the six SCHs are used for service message transmission. Also, the RSU sends back an ack message if it successfully receives a safety message in order to improve the reliability of safety message. Hence, a safety message can be retransmitted until it is successfully transmitted. See the last part of Table 3 for the parameter settings for CR-MAC and WAVE-DR.

Fig. 14 shows safety message throughput. It can be observed from the figure that VCAR-MAC outperforms the others due to the dedicated CCH usage for safety message transmission and unique time slot allocation for each vehicle, which leads to full utilization of the channel bandwidth. On the other hand, in CR-MAC and WAVE, the safety message is transmitted based on DCF-based contention, prohibiting the full utilization of the channel bandwidth. The performance of CR-MAC is worse than that of WAVE-DR

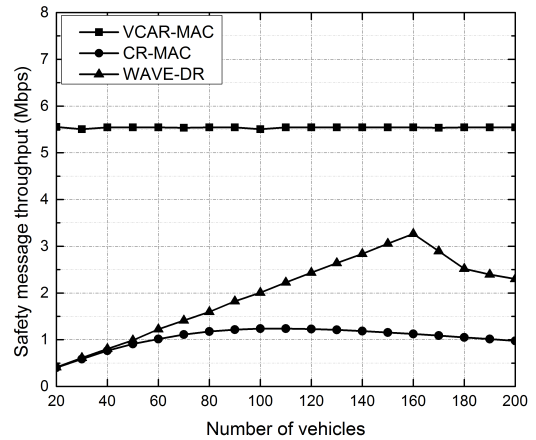

FIGURE 14. The safety message throughput.

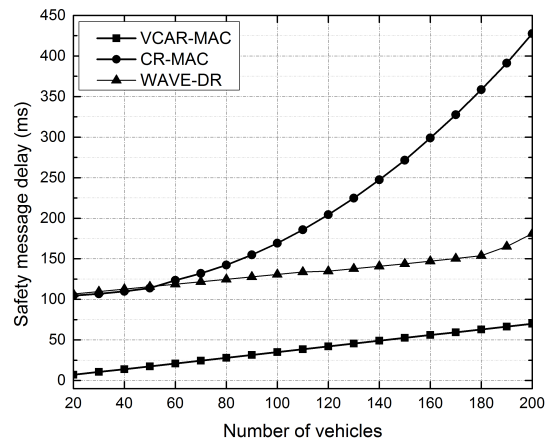

FIGURE 15. The safety message delay.

because in CR-MAC, the CCH is shared by safety and SCH reservation messages through DCF-based channel access mechanism.

Fig. 15 shows safety message delay. The safety message delay is defined as the duration between consecutive successful safety message transmissions in the same vehicle. From the figure, it can be observed that the delay increases with the number of vehicles. VCAR-MAC outperforms the others due to the reason that in VCAR-MAC, each identified vehicle is allocated a unique time slot to transmit safety messages, allowing limited delay, while in the others, the safety message transmission is based on DCF, wherein the delay increases rapidly as the number of vehicles increases. Also, WAVE has better performance than CR-MAC because in WAVE the CCH is dedicated for safety message transmission, while in CR-MAC, the CCH is shared by safety and SCH reservation messages.

Fig. 16 shows service message throughput. It is obvious that the analytical result well matches the simulation curve for VCAR-MAC. When the number of vehicles is less than 27, CR-MAC has better performance than VCAR-MAC due to the reason that in VCAR-MAC, service message transmission

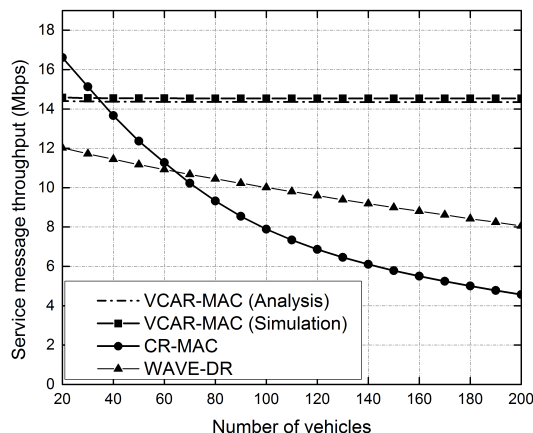

FIGURE 16. The service message throughput.

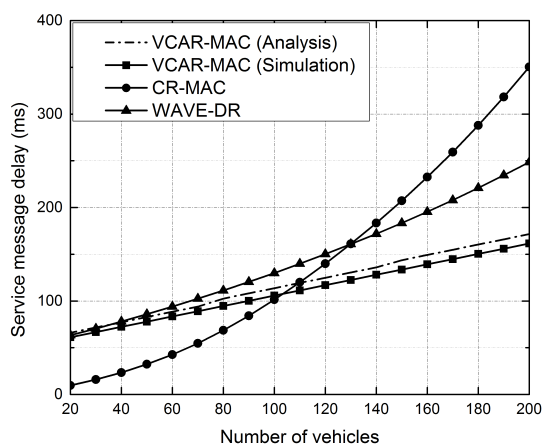

FIGURE 17. The service message delay.

is limited to STP, while in CR-MAC the full bandwidths of the six channels can be used for service message transmission. When the number of vehicles exceeds 27, VCAR-MAC outperforms due to the optimal initial CW size and SRP length.

Fig. 17 shows service message delay. It is clear that the analytical result well matches the simulation curve. The delay increases as the number of vehicles increases due to the higher channel contention. When the number of vehicles is less than 100, CR-MAC outperforms VCAR-MAC. This is because the larger initial CW size of VCAR-MAC results in the longer delay. However, the VCAR-MAC outperforms CR-MAC as the number of vehicles exceeds 100.

V. CONCLUSION

In this paper, we have proposed VCAR-MAC scheme for VANETs. VCAR-MAC provides contention-free safety message broadcasting service using a novel TDMA-based scheme that takes account of real world environmental conditions. Each vehicle within the RSU coverage can be identified quickly in order to allocate a time slot for reliable safety message transmission. For the service message transmission, a multichannel coordination scheme is proposed, wherein the initial CW size and the SCH reservation period are optimized

in order to maximize service message throughput. Both analytical results and simulation experiments have shown that the proposed VCAR-MAC can significantly improve throughput and decrease transmission delay for both safety and service messages.

REFERENCES

- [1] P. Papadimitratos, A. De La Fortelle, K. Evenssen, R. Brignolo, and S. Cosenza, "Vehicular communication systems: Enabling technologies, applications, and future outlook on intelligent transportation," *IEEE Commun. Mag.*, vol. 47, no. 11, pp. 84–95, Nov. 2009.
- [2] O. K. Tonguz and W. Viriyasitvat, "Cars as roadside units: A self-organizing network solution," *IEEE Commun. Mag.*, vol. 51, no. 12, pp. 112–120, Dec. 2013.
- [3] "Vehicle safety communications project task 3 final report," CAMP Vehicle Saf. Commun. Consortium, U.S. Dept. Transp., Nat. Highway Traffic Saf. Admin., Washington, DC, USA, Tech. Rep. DOT HS 809 859, Mar. 2005.
- [4] A. A. Carter, "The status of vehicle-to-vehicle communication as a means of improving crash prevention performance," Nat. Highway Traffic Saf. Admin., Fort Worth, TX, USA, Tech. Rep. 05-0264, Aug. 2012.
- [5] Q. Wang, P. Fan, and K. B. Letaief, "On the joint V2I and V2V scheduling for cooperative vanets with network coding," *IEEE Trans. Veh. Technol.*, vol. 61, no. 1, pp. 62–73, Jan. 2012.
- [6] R. A. Uzcategui, A. J. D. Sucre, and G. Acosta-Marum, "Wave: A tutorial," *IEEE Commun. Mag.*, vol. 47, no. 5, pp. 126–133, May 2009.
- [7] *IEEE Standard for Information Technology—Local and Metropolitan Area Networks—Specific Requirements—Part 11: Wireless LAN Medium Access Control (MAC) and Physical Layer (PHY) Specifications Amendment 6: Wireless Access in Vehicular Environments*, IEEE Standard 802.11p-2010, 2010, pp. 1–51.
- [8] *IEEE Standard for Wireless Access in Vehicular Environments (WAVE)—Multi-Channel Operation*, IEEE Standard 1609.4-2010, Revision 1609.4-2006, 2011, pp. 1–89.
- [9] M. D. Felice, A. J. Ghandour, H. Artail, and L. Bononi, "On the impact of multi-channel technology on safety-message delivery in IEEE 802.11p/1609.4 vehicular networks," in *Proc. IEEE Int. Conf. ICCCN*, Jul./Aug. 2012, pp. 1–8.
- [10] C. Campolo, A. Molinaro, A. Vinel, and Y. Zhang, "Modeling prioritized broadcasting in multichannel vehicular networks," *IEEE Trans. Veh. Technol.*, vol. 61, no. 2, pp. 687–701, Feb. 2012.
- [11] R. F. Atallah, M. J. Khabbaz, and C. M. Assi, "Modeling and performance analysis of medium access control schemes for drive-thru Internet access provisioning systems," *IEEE Trans. Intell. Transp. Syst.*, vol. 16, no. 6, pp. 3238–3248, Dec. 2015.
- [12] Y. Kim, Y. H. Bae, D.-S. Eom, and B. D. Choi, "Performance analysis of a MAC protocol consisting of EDCA on the CCH and a reservation on the SCHs for the IEEE 802.11p/1609.4 WAVE," *IEEE Trans. Veh. Technol.*, vol. 66, no. 6, pp. 5160–5175, Jun. 2017.
- [13] C. Campolo and A. Molinaro, "Multichannel communications in vehicular ad hoc networks: A survey," *IEEE Commun. Mag.*, vol. 51, no. 5, pp. 158–169, May 2013.
- [14] D. N. M. Dang, C. S. Hong, S. Lee, and E.-N. Huh, "An efficient and reliable MAC in VANETs," *IEEE Commun. Lett.*, vol. 18, no. 4, pp. 616–619, Apr. 2014.
- [15] N. Lu, Y. Ji, F. Liu, and X. Wang, "A dedicated multi-channel MAC protocol design for VANET with adaptive broadcasting," in *Proc. IEEE Int. Conf. ICCCN*, Apr. 2010, pp. 1–6.
- [16] F. Borgonovo, A. Capone, M. Cesana, and L. Fratta, "RR-ALOHA, a reliable R-ALOHA broadcast channel for ad-hoc inter-vehicle communication networks," in *Proc. 1st Annu. Med-Hoc-Net*, Sep. 2002, pp. 58–70.
- [17] Q. Wang, S. Leng, H. Fu, and Y. Zhang, "An IEEE 802.11p-based multichannel MAC scheme with channel coordination for vehicular ad hoc networks," *IEEE Trans. Intell. Transp. Syst.*, vol. 13, no. 2, pp. 449–458, Jun. 2012.
- [18] L. Cheng, B. E. Henty, D. D. Stancil, F. Bai, and P. Mudalige, "Mobile vehicle-to-vehicle narrow-band channel measurement and characterization of the 5.9 GHz dedicated short range communication (DSRC) frequency band," *IEEE J. Sel. Areas Commun.*, vol. 25, no. 8, pp. 1501–1516, Oct. 2007.

- [19] X. Yin, X. Ma, K. S. Trivedi, and A. Vinel, "Performance and reliability evaluation of BSM broadcasting in DSRC with multi-channel schemes," *IEEE Trans. Comput.*, vol. 63, no. 12, pp. 3101–3113, Dec. 2014.
- [20] D. Jiang, Q. Chen, and L. Delgrossi, "Optimal data rate selection for vehicle safety communications," in *Proc. ACM Int. Workshop VANET*, Jul. 2008, pp. 30–38.
- [21] E. P. C. Kao, *An Introduction to Stochastic Processes*. Duxbury, MA, USA: Duxbury Press, 1997.
- [22] W. Feller, *An Introduction to Probability Theory and Its Applications*, 2nd ed. New York, NY, USA: Wiley, 1971.
- [23] *SUMO Simulation of Urban Mobility*. Accessed: Jun. 29, 2019. [Online]. Available: <http://sumo.sourceforge.net/>
- [24] R. F. Atallah, M. J. Khabbaz, and C. M. Assi, "Vehicular networking: A survey on spectrum access technologies and persisting challenges," *Veh. Commun.*, vol. 2, no. 3, pp. 125–149, Jul. 2015.



SHENGBIN CAO received the Ph.D. degree in computer science from the City University of Hong Kong, Hong Kong, in 2018. His current research interests include vehicular ad hoc networks, including medium-access control (MAC) protocol design and performance analysis, D2D communications, and edge computing.



VICTOR C. S. LEE (M'92) received the Ph.D. degree in computer science from the City University of Hong Kong, Hong Kong, in 1997, where he is currently an Assistant Professor with the Department of Computer Science. His current research interests include data dissemination in vehicular networks, real-time databases, and performance evaluation. He is also a member of the ACM and the IEEE Computer Society. He was the Chairman of the IEEE Hong Kong Section Computer Chapter, from 2006 to 2007.

• • •