

Received December 5, 2018, accepted January 8, 2019, date of publication January 15, 2019, date of current version February 6, 2019.

Digital Object Identifier 10.1109/ACCESS.2019.2893019

Binary Data Gathering With a Helper in Internet of Things: Distortion Analysis and Performance Evaluation

WENSHENG LIN¹, (Student Member, IEEE), XIN HE²,
MARKKU JUNTTI³, (Senior Member, IEEE),
AND TAD MATSUMOTO^{1,3}, (Fellow, IEEE)

¹School of Information Science, Japan Advanced Institute of Science and Technology, Ishikawa 923-1292, Japan

²School of Computer and Information, Anhui Normal University, Wuhu 241002, China

³Centre for Wireless Communications, University of Oulu, 90014 Oulu, Finland

Corresponding author: Wensheng Lin (linwest@jaist.ac.jp)

This work was supported in part by the China Scholarship Council (CSC), in part by JAIST Core-to-Core Program, in part by the National Natural Science Foundation of China (NSFC), under Grant 61702011, in part by the Anhui Provincial Natural Science Foundation, under Grant 1808085QF191, and in part by the Academy of Finland 6Genesis Flagship under Grant 318927.

ABSTRACT This paper focuses on one-helper assisted binary data gathering networks, for example, such as in Internet of Things, where a destination makes estimates of binary data relying on a number of agents and one helper. Due to the noise, corrupting errors already exist in the agent observations. To analyze the performance of this system, we formulate this system as a binary chief executive officer (CEO) problem with a helper. Initially, we use a successive decoding scheme to decompose the binary CEO problem with a helper into the multiterminal source coding and final decision problems. Then, we present an outer bound on the rate-distortion region for multiterminal source coding with binary sources and a helper. After solving a convex optimization problem formulated from the derived outer bound, we obtain the final distortion by substituting the minimized distortions of observation into the distortion propagating function, which is derived to bridge the relationship between the joint decoding results and final decision. Finally, we analyze the trade-off of rate-distortion through theoretical calculation and simulations. Both the theoretical and simulation results demonstrate that a helper can obviously reduce the signal-to-noise ratio threshold. We also have an in-depth discussion on the differences of system performance improvement between locating a helper and including an additional agent.

INDEX TERMS Binary CEO problem, binary data gathering, Internet of Things, rate-distortion, side information.

I. INTRODUCTION

Internet of Things (IoT) attracts increasing attentions of academia and industry, owing to the significant role of IoT in the smart society. Due to the frequent use of binary signalling, in general, binary data gathering plays fundamental roles of IoT in the big data era. Generally, binary data gathering is based on direct detection and/or with the aid of agents. However, direct transmissions are almost impossible in some strict communications environment, e.g., path loss due to the long distance between the original binary data and the destination, and/or time varying nature of the channels due to fading. Therefore, the destination has to only rely on the data received from the agents and make estimations of the original binary

data. Essentially, this scenario can be formulated as the chief executive officer (CEO) problem [1] with binary sources. In the ordinary case, the agent observations of the original data may contain errors when the agents suffer from noise. Consequently, the estimate of the target information could be a lossy recovery, if the rates supported by the channels are not large enough due to the harsh communications environment.

Nowadays, to make connections more robust and enhance the system performance, several wireless communications systems introduce the concept of helper [2]–[5]. These applications of the helper inspire us to refine the performance of binary data gathering in IoT system by the assistance of a helper. As illustrated in Fig. 1, there are many agents

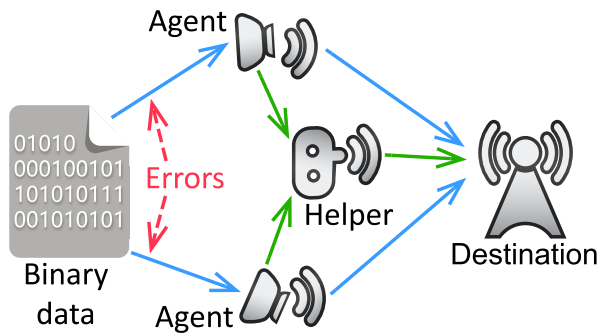

FIGURE 1. A scenario of binary data gathering with a helper in IoT.

observing the same binary data while errors corrupt the data sequences. Subsequently, the agents independently encode and transmit the error-corrupted sequences to the destination; meanwhile, a helper generates the helper sequence by monitoring the agents and then send it to the destination. After decoding the received sequences from all agents and the helper, the destination makes the final estimation of the original binary data.

Since the system model shown in Fig. 1 can be formulated as a binary CEO problem with a helper, we can analyze the system performance inspired by the previous achievements related to the binary CEO problem. He *et al.* [6] presented a lower bound of Hamming distortion for the binary CEO problem with two sources, and the result was further extended to solve the binary CEO problem with many sources in [7]. Razi and Abedi [8] developed a method to analyze the convergence of iterative decoding for the binary CEO problem. An iterative joint decoding algorithm was implemented into the wireless sensor networks (WSNs) with binary sources according to the model of binary CEO problem by Haghghat *et al.* [9]. It is noticed that the binary CEO problem is solved in [6] and [7] by decomposing the problem into multiterminal source coding and final decision, i.e., a successive decoding process. Likewise, for the performance analysis of the binary CEO problem with a helper, we can start from the problem of multiterminal source coding with a helper and then investigate the distortion of final decision.

Regarding the theoretical work related to multiterminal source coding with a helper or side information, Ahlswede and Korner [10] derived the rate region for source coding with a helper providing side information. Wyner and Ziv [11] characterized the rate-distortion function for lossy compression with side information, where only one source needs to be recovered and another one provides assistance without rate limit. Slepian and Wolf [12] presented the fundamental theorem of lossless multiterminal source coding, where each source can be viewed as the side information for another one. The Slepian-Wolf theorem asserts a surprising result that distributed compression has the same achievable rate region as joint source coding. For the system without necessary requirements of the full source recoveries, Berger [13] and

Tung [14] derived the inner and outer bounds on the rate-distortion region of the lossy multiterminal source coding problem. Wagner and Anantharam [15] extended the Berger-Tung bounds to the case with multiple sources and one link of uncompressed side information.

In the final decision step, the bit error probability of binary data gathering was analyzed in [16], where many correlated sources in a WSN have diverse bit-flipping probabilities, and soft combining is implemented as the final decision rule. Based on these previous achievements, we establish the framework of the binary CEO problem with a helper as a successive encoding/decoding process, i.e., encoding/decoding the multiple sources with the assistance of a helper and then combining the joint decoding results. By this means, we have finished the performance analysis for binary data gathering with a helper in IoT.

The contributions of this paper are summarized as follows:

- To theoretically analyze the system performance, we formulate binary data gathering by a one-helper assisted IoT as a binary CEO problem with a helper. Based on the Berger-Tung outer bound, we derive an outer bound on the rate-distortion region of multiterminal source coding problem with many agents and a helper for binary sources. Then, the outer bound is utilized to formulate a convex optimization problem, for the purpose of minimizing distortions when reconstructing observations.
- Moreover, we analyze the distortion propagating from the estimate of agent sequences to the final decision. By substituting the solution of the convex optimization problem, we investigate the trade-off of rate-distortion for binary data gathering with a helper in IoT.
- Finally, we propose a practical coding scheme and evaluate the system performance through simulations for binary data gathering with a helper in IoT. Besides, we make a comparison of performance improvement between the system with a helper and that with an additional agent.

The rest of this paper is organized as follows. Section II formulates binary data gathering with a helper in IoT as the binary CEO problem with a helper. In Section III, we analyze the rate-distortion performance of the formulated binary CEO problem with a helper. Then, Section IV evaluates the system performance through computer simulations for binary data gathering with a helper in IoT. Finally, we conclude this work in Section V.

II. SYSTEM MODEL

Notation: The random variables and their realizations are denoted by uppercase and lowercase letters, respectively. Calligraphic letters \mathcal{X} , \mathcal{Y} , \dots denote the finite alphabets of a random variable. The superscript of a random vector and its realization represent the length of the vector. We use t to denote the time index and i to denote the index of an agent. The random variable with a finite alphabet as subscript denotes a set of all random variables with index in the finite

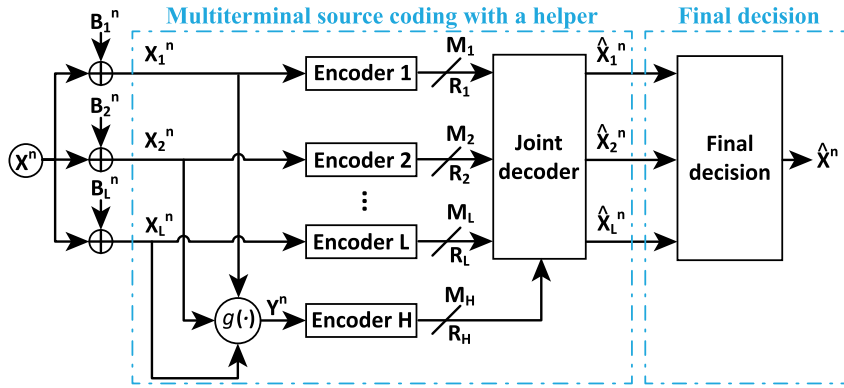

FIGURE 2. A binary CEO problem with a helper.

alphabet, such as $X_{\mathcal{L}} = \{X_i | i \in \mathcal{L}\}$. For a subset $\mathcal{S} \subseteq \mathcal{L}$, \mathcal{S}^c represents the corresponding complementary set.

As mentioned above, the IoT system depicted in Fig. 1 can be formulated as the binary CEO problem with a helper in Fig. 2, where a binary source X acts as a common source. The discrete memoryless source (DMS) X generates independent and identically distributed (i.i.d.) sequence $x^n = \{x(t)\}_{t=1}^n$ by taking values from the binary alphabet $\mathcal{X} = \{0, 1\}$ for each time slot. The source X is observed by L agents at the same time. Due to the influence of noise, the observation $x_i^n = \{x_i(t)\}_{t=1}^n$, where $i \in \mathcal{L} = \{1, 2, \dots, L\}$, may contains errors $b_i^n = \{b_i(t)\}_{t=1}^n$ [1]. Hence, the error probability $\Pr\{x_i(t) \neq x(t)\} = p_i$ for $B_i \sim \text{Bern}(p_i)$. The erroneous sequences are still forwarded to the destination, which is referred to as lossy-forward [17], [18]. Simultaneously, a helper generates the helper sequence $y^n = \{y(t)\}_{t=1}^n$ from the agent sequences bit by bit, and then transmits the helper sequence to the destination after compressing it. Therefore, all the X_i and Y can be also regarded as DMS. The sequences x_i^n and y^n are encoded at rates R_i and R_H by encoder i and encoder H, respectively. Encoder i and encoder H assign an index to each sequence according to the following mapping rules:

$$\varphi_i : \mathcal{X}_i^n \mapsto \mathcal{M}_i = \{1, 2, \dots, 2^{nR_i}\}, \quad (1)$$

$$\varphi_H : \mathcal{Y}^n \mapsto \mathcal{M}_H = \{1, 2, \dots, 2^{nR_H}\}. \quad (2)$$

Then, the encoder outputs $M_{\mathcal{L}}$ and M_H are transmitted to a joint decoder. The joint decoder constructs the estimates $\hat{x}_{\mathcal{L}}^n$ from indices $M_{\mathcal{L}}$ and M_H by utilizing the mapping rule, as:

$$\psi : \mathcal{M}_1 \times \mathcal{M}_2 \times \dots \times \mathcal{M}_L \times \mathcal{M}_H \mapsto \mathcal{X}_1^n \times \mathcal{X}_2^n \times \dots \times \mathcal{X}_L^n. \quad (3)$$

Since the estimate \hat{x}_i^n may occasionally deviate from the observation x_i^n , the Hamming distortion measure is defined to describe the distortion level between $x_i(t)$ and $\hat{x}_i(t)$, as

$$d_i(x_i(t), \hat{x}_i(t)) = \begin{cases} 1, & \text{if } x_i(t) \neq \hat{x}_i(t), \\ 0, & \text{if } x_i(t) = \hat{x}_i(t). \end{cases} \quad (4)$$

Hence, the expected distortion between the sequences x_i^n and \hat{x}_i^n is

$$d_i(x_i^n, \hat{x}_i^n) = \frac{1}{n} \sum_{t=1}^n d_i(x_i(t), \hat{x}_i(t)). \quad (5)$$

For given distortion values $D_{\mathcal{L}}$, the rate-distortion region $\mathcal{R}(D_{\mathcal{L}})$, consisting of all achievable rate tuple $(R_{\mathcal{L}}, R_H)$, is defined as

$$\mathcal{R}(D_{\mathcal{L}}) = \{(R_{\mathcal{L}}, R_H) : (R_{\mathcal{L}}, R_H) \text{ is admissible such that } \lim_{n \rightarrow \infty} E(d_i(x_i^n, \hat{x}_i^n)) \leq D_i + \epsilon, \text{ for } i \in \mathcal{L}, \text{ and any } \epsilon > 0\}. \quad (6)$$

Finally, the destination reconstructs the estimate of x^n from $\hat{x}_{\mathcal{L}}^n$. Obviously, the distortion between x_i^n and \hat{x}_i^n will determine the final estimate \hat{x}^n . Hence, the final distortion

$$E \left[\frac{1}{n} \sum_{t=1}^n d(x(t), \hat{x}(t)) \right] \leq D + \epsilon, \quad (7)$$

can be formulated as a function $F_{\text{DP}}(\cdot)$ of $D_{\mathcal{L}}$, where $F_{\text{DP}}(\cdot)$ is referred to as distortion propagating function (DPF). The DPF is defined as $D = F_{\text{DP}}(D_{\mathcal{L}})$, which highly depends on the decision rule. It should be emphasized here that the DPF limits the decoding scheme to successive decoding, i.e., first reconstructing $\hat{x}_{\mathcal{L}}^n$ and then making the final decision.

III. RATE-DISTORTION ANALYSIS

The first step of performance analysis for binary data gathering with a helper in IoT is to derive an outer bound on the achievable rate-distortion region of multiterminal source coding with a helper. By utilizing the derived outer bound, we can formulate a convex optimization problem to minimize the distortions in the step of multiterminal source coding. Then, by investigating the DPF with respect to specified decision rule, we can obtain the distortion of final decision and finish the performance analysis.

A. MULTITERMINAL SOURCE CODING WITH A HELPER

1) OUTER BOUND OF RATE-DISTORTION REGION

From the extended Berger-Tung outer bound [15] with multiple sources and one link of side information, we can obtain

the outer bound for multiterminal source coding with a helper as presented in the following proposition.

Proposition 1: Let $(X_{\mathcal{L}}, Y)$ be a $(L + 1)$ -DMS and $d_i(x_i, \hat{x}_i)$ for $i \in \mathcal{L}$ be distortion measures. If a rate tuple $(R_{\mathcal{L}}, R_H)$ is achievable with distortion tuple $D_{\mathcal{L}}$ for distributed lossy source coding with a helper observing Y , then it must satisfy the inequalities

$$\sum_{i \in \mathcal{S}} R_i \geq I(X_{\mathcal{L}}; U_S | U_{S^c}, V), \quad (8)$$

$$R_H \geq I(Y; V), \quad (9)$$

for some conditional probability mass function $p(u_{\mathcal{L}}, v | x_{\mathcal{L}}, y)$, and functions $\hat{x}_i(u_{\mathcal{L}}, v)$ such that $U_i \rightarrow X_i \rightarrow X_j$ and $X_i \rightarrow X_j \rightarrow U_j$ form Markov chains and $E(d_i(X_i, \hat{X}_i)) \leq D_i$, where $i, j \in \mathcal{L}$ and $i \neq j$.

It is easy to understand that the constraint of (9) results from the rate limit on the helper instead of uncompressed side information. Then, we introduce the definitions to be used in the derivation of the outer bound for binary sources.

Definition 1: We define the following variables:

$$\alpha_i = p_i * h^{-1}(1 - [R_i]^-), \quad (10)$$

$$\beta_i = p_i * D_i, \quad (11)$$

where the operation $*$ denotes the binary convolution process; $[R_i]^- = \min\{1, R_i\}$; $h(\cdot)$ and $h^{-1}(\cdot)$ denote the binary entropy function and its inverse, respectively.

Definition 2: According to [7], given a set of crossover probabilities $\{\mathcal{P}\}$ with a common source X , the joint entropy $f(\cdot)$ of the outputs from independent binary symmetric channels (BSCs) is calculated as

$$f(\{\mathcal{P}\}) = - \sum_{j=1}^{2^{|\mathcal{P}|}} q_j \log_2(q_j), \quad (12)$$

where $|\cdot|$ denotes the cardinality of the set, and

$$q_j = 0.5 \left(\prod_{k \in \mathcal{A}_i} p_k \prod_{k' \in \mathcal{A}_i^c} \bar{p}_{k'} + \prod_{k \in \mathcal{A}_i} \bar{p}_k \prod_{k' \in \mathcal{A}_i^c} p_{k'} \right), \quad (13)$$

with $\bar{p} = 1 - p$ and $\mathcal{A}_i \subseteq \{1, 2, \dots, |\mathcal{P}|\}$.

Now, we calculate the outer bound for binary sources. Consider

$$\begin{aligned} \sum_{i \in \mathcal{S}} R_i &\geq I(X_{\mathcal{L}}; U_S | U_{S^c}, V) \\ &= H(X_{\mathcal{L}} | U_{S^c}, V) - H(X_{\mathcal{L}} | U_S, U_{S^c}, V) \\ &= H(X_{\mathcal{L}} | U_{S^c}) - I(X_{\mathcal{L}}; V | U_{S^c}) \\ &\quad - H(X_{\mathcal{L}} | U_S, U_{S^c}) + I(X_{\mathcal{L}}; V | U_S, U_{S^c}) \\ &= I(X_{\mathcal{L}}; U_S | U_{S^c}) - I(X_{\mathcal{L}}; V | U_{S^c}) \\ &\quad + I(X_{\mathcal{L}}; V | U_S, U_{S^c}) \\ &= I(X_{\mathcal{L}}; U_S | U_{S^c}) + I(X_S; V | U_{\mathcal{L}}) \\ &\quad - I(X_S; V | U_{\mathcal{L}}) - I(X_{\mathcal{L}}; V | U_{S^c}) \\ &\quad + I(X_{\mathcal{L}}; V | U_S, U_{S^c}). \end{aligned} \quad (14)$$

Then, we calculate $I(X_{\mathcal{L}}; U_S | U_{S^c}) + I(X_S; V | U_{\mathcal{L}})$ and $-I(X_S; V | U_{\mathcal{L}}) - I(X_{\mathcal{L}}; V | U_{S^c}) + I(X_{\mathcal{L}}; V | U_S, U_{S^c})$ separately. Consider

$$\begin{aligned} &I(X_{\mathcal{L}}; U_S | U_{S^c}) + I(X_S; V | U_{\mathcal{L}}) \\ &= I(X_S; U_S | U_{S^c}) + I(X_{S^c}; U_S | U_{S^c}, X_S) \\ &\quad + I(X_S; V | U_{\mathcal{L}}) \\ &= I(X_S; U_S | U_{S^c}) + H(X_{S^c} | U_{S^c}, X_S) \\ &\quad - H(X_{S^c} | U_S, U_{S^c}, X_S) + I(X_S; V | U_{\mathcal{L}}) \\ &= I(X_S; U_S | U_{S^c}) + H(X_{S^c} | U_{S^c}, X_S) \\ &\quad - H(X_{S^c} | U_{S^c}, X_S) + I(X_S; V | U_{\mathcal{L}}) \quad (15) \\ &= I(X_S; U_S | U_{S^c}) + I(X_S; V | U_{\mathcal{L}}) \\ &= I(X_S; U_S, U_{S^c}) - I(X_S; U_{S^c}) \\ &\quad + I(X_S; V | U_S, U_{S^c}) \\ &= I(X_S; U_{\mathcal{L}}, V) - I(X_S; U_{S^c}) \\ &\geq I(X_S; \hat{X}_S) - I(X_S; U_{S^c}), \end{aligned} \quad (16)$$

where (15) follows the fact that $U_i \rightarrow X_i \rightarrow X_j$ form a Markov chain for $i \in \mathcal{S}$ and $j \in \mathcal{S}^c$; (16) follows data processing inequality when estimating \hat{X}_S from $(U_{\mathcal{L}}, V)$. By applying the result in [7] into (16), we have

$$\begin{aligned} &I(X_{\mathcal{L}}; U_S | U_{S^c}) + I(X_S; V | U_{\mathcal{L}}) \\ &\geq f(\{p_S, \alpha_{S^c}\}) - f(\{\alpha_{S^c}\}) - \sum_{i \in \mathcal{S}} h(D_i), \end{aligned} \quad (17)$$

Next, consider

$$\begin{aligned} &-I(X_S; V | U_{\mathcal{L}}) - I(X_{\mathcal{L}}; V | U_{S^c}) + I(X_{\mathcal{L}}; V | U_S, U_{S^c}) \\ &= -I(X_S; V | U_{\mathcal{L}}) - H(V | U_{S^c}) \\ &\quad + H(V | X_{\mathcal{L}}, U_{S^c}) + H(V | U_S, U_{S^c}) \\ &\quad - H(V | X_{\mathcal{L}}, U_S, U_{S^c}) \\ &= -I(X_S; V | U_{\mathcal{L}}) - H(V | U_{S^c}) + H(V | X_{\mathcal{L}}) \\ &\quad + H(V | U_S, U_{S^c}) - H(V | X_{\mathcal{L}}) \quad (18) \\ &= H(V | U_{\mathcal{L}}, X_S) - H(V | U_{\mathcal{L}}) - H(V | U_{S^c}) \\ &\quad + H(V | U_S, U_{S^c}) \\ &= -I(V; U_S, X_S | U_{S^c}) \\ &= -I(V; X_S | U_{S^c}), \end{aligned} \quad (19)$$

where (18) and (19) follow since $U_i \rightarrow X_i \rightarrow V$ form a Markov chain for $i \in \mathcal{L}$. To further calculate (19), consider

$$I(V; X_S | U_{S^c}) \leq I(V; X_S) \quad (20)$$

$$\leq I(V; Y) \quad (21)$$

$$\leq R_H, \quad (22)$$

where (20) follows since condition reduces entropy, and (21) follows since $X_S \rightarrow Y \rightarrow V$ form a Markov chain. Notice that the equality of (20) holds when no mutual information exists between V and U_{S^c} , i.e., the helper allocates full rate to help recovering X_S . The equality of (21) holds when the helper only utilize X_S to generate the helper information Y .

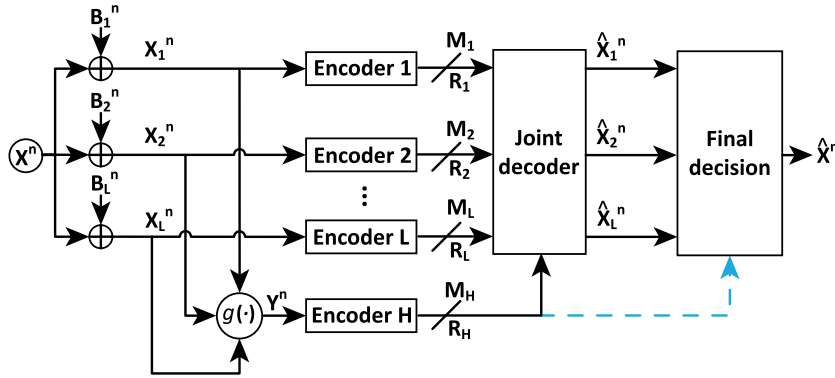

FIGURE 3. The system model for final decision with compressed side information.

Moreover, the equality of (22) holds when the helper rate is completely exploited for compression. Consequently, there is no waste of the helper rate if the conditions for the equality of (20-22) are satisfied. In this case, it is obvious that the structure of the helper is optimal. By assuming that we have an optimal helper and substituting (17), (19) and (22) into (14), we can finally obtain

$$\sum_{i \in \mathcal{S}} R_i \geq f(\{p_{\mathcal{S}}, \alpha_{\mathcal{S}^c}\}) - f(\{\alpha_{\mathcal{S}^c}\}) - \sum_{i \in \mathcal{S}} h(D_i) - R_H. \quad (23)$$

Remark 1: Since we assume that the structure of the helper is optimal, the constraint on the helper link, i.e., the inequality (9), is satisfied by the helper encoder, which finds a proper codeword M_H to make $I(Y; V)$ as large as possible.

Remark 2: If we set $R_H = 0$, i.e., the helper link is equivalently cut off, (23) reduces to the outer bound without a helper in [7].

2) DISTORTION MINIMIZATION

Since the final distortion D is a function of $D_{\mathcal{L}}$ by the successive decoding for given $R_{\mathcal{L}}$ and R_H , we can first minimize the l_2 -norm of the vector $[D_1, D_2, \dots, D_L]$ by solving a convex optimization problem [6], [7], which is formulated from the outer bound. Then, we calculate the minimum distortion D^* by substituting the solution of the convex optimization problem into DPF. Notice that for a practical communications system with channels, the channel capacity should also be taken into consideration. According to Shannon's lossy source-channel separation theorem [19], [20], the distortion tuple $D_{\mathcal{L}}$ is achievable if the following inequalities hold:

$$\begin{cases} R_i(D_i) \cdot r_i \leq C(\gamma_i), & \text{for } i \in \mathcal{L}, \\ R_H \cdot r_H \leq C(\gamma_H), \end{cases} \quad (24)$$

where $C(\gamma_i)$ and $C(\gamma_H)$ are the Shannon capacity using Gaussian codebook with γ as the signal-to-noise ratio (SNR) of the channel; r_i and r_H represent the end-to-end coding rates [21] of each agent link and the helper link, respectively. By applying the outer bound derived above, we can formulate the convex optimization problem for the system with an optimal

helper as

$$\begin{aligned} & \min_{D_1, D_2, \dots, D_L} \|[D_1, D_2, \dots, D_L]\|_2 \\ & \text{s.t. } \sum_{i \in \mathcal{S}} h(D_i) \geq f(\{p_{\mathcal{S}}, \alpha_{\mathcal{S}^c}\}) - f(\{\alpha_{\mathcal{S}^c}\}) - \sum_{i \in \mathcal{S}} \frac{C(\gamma_i)}{r_i} \\ & \quad - \frac{C(\gamma_H)}{r_H}, \\ & \quad 0 \leq D_i \leq 0.5, i \in \mathcal{L}. \end{aligned} \quad (25)$$

After solving the convex optimization problem, we can obtain the minimum value of distortion D_i^* for $i \in \mathcal{L}$. Then, we use the estimates $\hat{X}_{\mathcal{L}}^n$ with minimum distortions $D_{\mathcal{L}}^*$ to make final decision.

B. FINAL DECISION

Notice that the compressed side information V^n is not used in the final decision to minimize the distortion between X^n and \hat{X}^n . Hence, it is necessary to discuss the influence of the compressed side information on final decision. We consider the theoretically optimal case and a practical case, i.e., majority voting decision, respectively. For the final decision with compressed side information, i.e., the system model shown in Fig. 3, when the final decision is optimal, consider

$$\begin{aligned} H(X) - h(\tilde{d}) & \leq I(X; \hat{X}) \\ & \leq I(X; \hat{X}_{\mathcal{L}}, V) \end{aligned} \quad (26)$$

$$\begin{aligned} & = I(X; \hat{X}_{\mathcal{L}}) + I(X; V | \hat{X}_{\mathcal{L}}) \\ & = I(X; \hat{X}_{\mathcal{L}}) + H(V | \hat{X}_{\mathcal{L}}) - H(V | \hat{X}_{\mathcal{L}}, X) \\ & = I(X; \hat{X}_{\mathcal{L}}), \end{aligned} \quad (27) \quad (28)$$

where \tilde{d} is a dummy variable, and the steps are justified as: (26) according to data processing inequality, information loss may happen in the final decision,

(27) notice that V is a function of Y and Y is a function of $X_{\mathcal{L}}$, and hence V is a function of $X_{\mathcal{L}}$, i.e., $V = g'(X_{\mathcal{L}})$. If $H(V | \hat{X}_{\mathcal{L}}) = H(g'(X_{\mathcal{L}}) | \hat{X}_{\mathcal{L}}) > 0$, it means that there is still some information of $X_{\mathcal{L}}$ not utilized in joint decoding. Hence, some distortions D_i for $i \in \mathcal{L}$ can be further reduced in the convex optimization problem. Consequently, we have

$H(V|\hat{X}_{\mathcal{L}}) = 0$ and $H(V|\hat{X}_{\mathcal{L}}, X) = 0$ for the best utilization of helper information in multiterminal source coding.

It is obvious that (26) is equal to (28), i.e., the compressed side information does not change the minimum final distortion. Similarly, for the majority voting decision, since we use the successive decoding scheme, the distortions $D_{\mathcal{L}}$ must be minimized after joint decoding. This means that the helper information has been completely utilized in joint decoding step. Hence, the final distortion will not further reduce, whether the compressed side information is taken into consideration or not in the majority voting decision. It is sufficient to derive the DPF $F_{DP}(D_{\mathcal{L}})$ for both optimal and majority voting decision without side information.

For the optimal decision rule, consider

$$\begin{aligned} H(X) - h(\tilde{d}) &\leq I(X; \hat{X}) \\ &\leq I(X; \hat{X}_{\mathcal{L}}) \\ &= H(X) + H(\hat{X}_{\mathcal{L}}) - H(X, \hat{X}_{\mathcal{L}}) \\ &= H(X) + f(\{\beta_{\mathcal{L}}\}) - f(\{0, \beta_{\mathcal{L}}\}), \end{aligned} \quad (29)$$

where the steps are justified as:

(29) the probable information loss in the final decision,

(30) X can be regarded as the output of a BSC with itself as the input and the crossover probability equal to 0.

Consequently, we have

$$\tilde{d} \geq h^{-1}[f(\{0, \beta_{\mathcal{L}}\}) - f(\{\beta_{\mathcal{L}}\})]. \quad (31)$$

Obviously, the minimum final distortion D , i.e., the distortion by optimal decision, is given by

$$D = h^{-1}[f(\{0, \beta_{\mathcal{L}}\}) - f(\{\beta_{\mathcal{L}}\})]. \quad (32)$$

Since the optimal decision specifies a universal lower bound, here, we consider another practical decision scheme, i.e., majority voting. The distortion between X^n and \hat{X}^n by majority voting is the sum probability of several events in a Poisson binomial process [16]. We introduce a function to evaluate the distortion in a Poisson binomial process as follows:

Definition 3: Poisson binomial distortion function [16]. The distortion between X^n and \hat{X}^n , which is estimated from $\hat{X}_{\mathcal{L}}^n$ by majority voting, is calculated by $D = PB(\beta_{\mathcal{L}})$ as

$$PB(\beta_{\mathcal{L}}) = \begin{cases} \sum_{j=\frac{L+1}{2}}^L \Pr(J=j), & \text{if } L \text{ is odd,} \\ \frac{1}{2}\Pr(J=\frac{L}{2}) \\ + \sum_{j=\frac{L}{2}+1}^L \Pr(J=j), & \text{if } L \text{ is even,} \end{cases} \quad (33)$$

where

$$\Pr(J=j) = \begin{cases} \prod_{i=1}^L (1 - \beta_i), & j = 0, \\ \frac{1}{j} \sum_{i=1}^j (-1)^{(i-1)} \Pr(J=j-i) \lambda(i), & j > 0, \end{cases} \quad (34)$$

with $\lambda(i) = \sum_{k=1}^L (\frac{\beta_k}{1-\beta_k})^i$ for $0 \leq j \leq L$.

By utilizing the Poisson binomial distortion function, we can calculate the distortion D by majority voting among $\hat{X}_{\mathcal{L}}$ as

$$D = PB(\beta_{\mathcal{L}}). \quad (35)$$

Remark: If p_i are various among all links, weighted majority voting should be implemented to generate more accurate estimate of X^n . The error probability by weighted majority voting is presented in Appendix. In this paper, we focus on the system with homogeneous agents for simplicity, and the results can be easily extended to the case with heterogeneous agents according to Appendix.

In summary, the DPFs for optimal decision and majority voting are (32) and (35), respectively. Therefore, we can obtain the minimum final distortion between X^n and \hat{X}^n by substituting the solution $D_{\mathcal{L}}^*$ of the convex optimization problem into DPF as $D^* = F_{DP}(\beta_{\mathcal{L}}^*)$, where $\beta_{\mathcal{L}}^* = \{p_i * D_i^* | i \in \mathcal{L}\}$.

C. NUMERICAL RESULTS

Now, we start investigations on the trade-off of rate-distortion for binary data gathering with a helper in IoT through numerical results. A memoryless source $X \sim \text{Bern}(0.5)$ is used in the following. Initially, we compare the bit error rate (BER) performance between majority voting and optimal decision. By utilizing the DPF after solving a corresponding convex optimization problem, we can depict the curve of SNR for each link versus BER as shown in Fig. 4. All the crossover probabilities between X and X_i are set at the same value of 0.01. Moreover, the end-to-end coding rate is set at $\frac{1}{2}$, and the SNR is set at the same level for all of the agent and helper links. Notice from the results that whether there is a helper or not, a gap obviously appears between the Poisson binomial (PB) process, i.e., majority voting, and the theoretical lower bound (LB), i.e., optimal decision. The reason for the performance gap is that it is extremely difficult to completely utilize the mutual information between X^n and $X_{\mathcal{L}}^n$. For instance, assuming that there are $2K$ agents with $X_t = X_{1,t} = \dots = X_{K,t} = 0$ and $X_{K+1,t} = \dots = X_{2K,t} = 1$ at some time index t , it is obvious that there is some mutual information between X_t and $\{X_{1,t}, \dots, X_{K,t}\}$. However, decision error will still occur in the Poisson binomial process, resulting in the loss of mutual information between X_t and \hat{X}_t . It should be also noticed that the gap is sensitive to the number of agents, i.e., the gap is smaller when there are odd number of agents. Because there could be equal number of “0” and “1” at the same bit of the agent sequences, if the number of agents

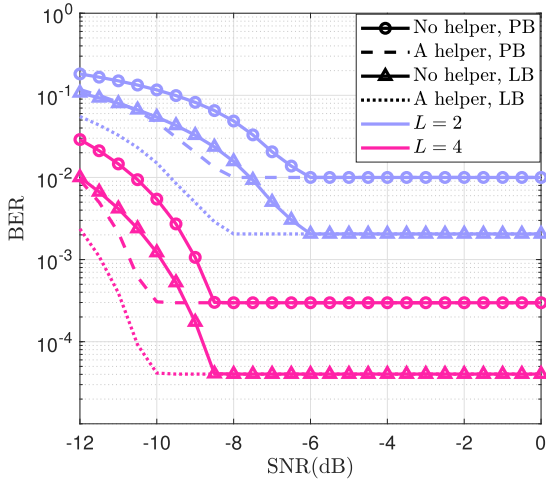

(a)

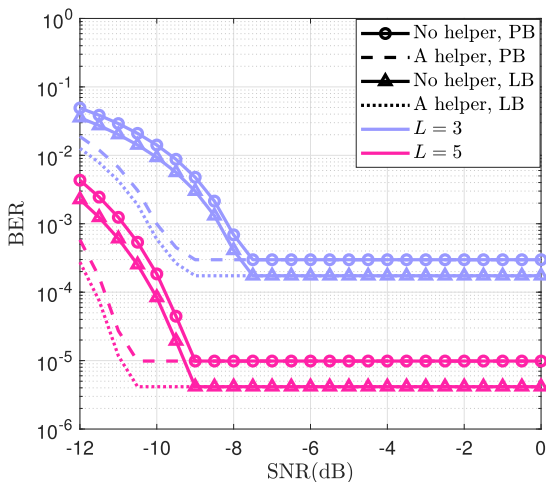

(b)

FIGURE 4. Comparison of system performance between majority voting and optimal decision, where $p_i = 0.01$. (a) The number of agents is even. The number of agents is odd.

is even. In this draw case, the bit of final decision by majority voting is randomly selected, resulting in more performance loss. Hence, the majority voting decision can achieve better performance if odd number of agents are deployed. For the effect of a helper, we find that the helper can reduce BER at small SNR value range, but keep the same BER floor as the case without a helper. Because for sufficiently large SNR, there is already no distortion between X_i^n and \hat{X}_i^n , and the side information Y^n generated from X_L^n becomes redundant.

We further investigate the effect on rate-distortion by introducing a helper with majority voting decision in Fig. 5. Since the rate allocation scheme is out of the scope in this paper, the rate is evenly allocated to all nodes including agents and helper. Surprisingly, the helper can reduce the final distortion D before achieving the distortion floor, even though the agent rate decreases by sharing the sum rate with a helper. This phenomenon indicates that it is possible to improve the system performance for multiple access channels with the

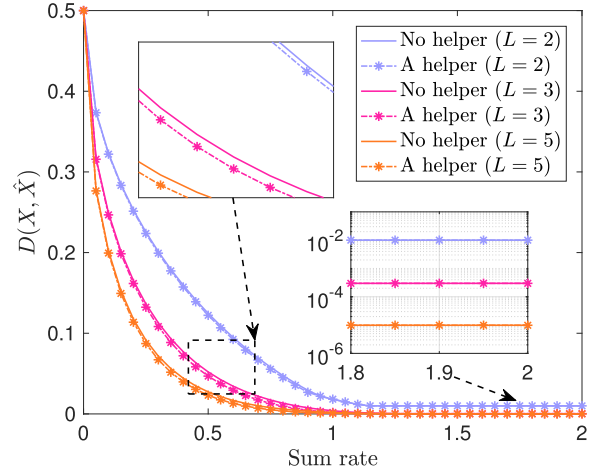

FIGURE 5. The trade-off of rate-distortion with a majority voting helper, where $p_i = 0.01$ for all agents.

same sum rate by introducing a helper. However, the curve with a helper will finally converge with the no-helper case at the same distortion floor. Notice the fact that the curve with a helper is still valuable, although the improvement is very small.

Finally, we make a comparison of rate-distortion between majority voting and optimal decision with diverse p_i . Fig. 6 shows an inclination that the more correlated observations are, i.e., p_i is smaller, the faster the distortion floor is achieved. Because it is easier to minimize the distortion between X_i^n and \hat{X}_i^n for more correlated observations, owing to more mutual information among the observations. Moreover, as the correlation among the agent observations increases, the distortion floor decreases for both majority voting and optimal decision. We can also find the same phenomenon as Fig. 4 that the gap between majority voting and optimal decision is smaller for odd number of agents, even if the number of agents in Fig. 6(a) is less than that in Fig. 6(b). In addition, since in the situation where the mutual information is lost less frequently with smaller p_i , the gap between majority voting and optimal decision is smaller with more correlated observations.

IV. PRACTICAL PERFORMANCE EVALUATION

A. SIMULATION DESIGN

In this section, we evaluate the practical performance of binary data gathering with a helper in IoT through simulations. As depicted in Fig. 7, there are L encoders separately encode the observations X_i^n , which is detected from a common source sequence X^n and mixed with the error B_i^n . Simultaneously, the encoder H encodes the side information Y^n generated from the agent observations. Next, the encoded sequences are sent to a fusion center through additive white Gaussian noise (AWGN) channels after modulation. The fusion center first demodulates the received signals and then jointly decodes them. Finally, the estimate of all sequences in the last round of iteration is used to make final decision.

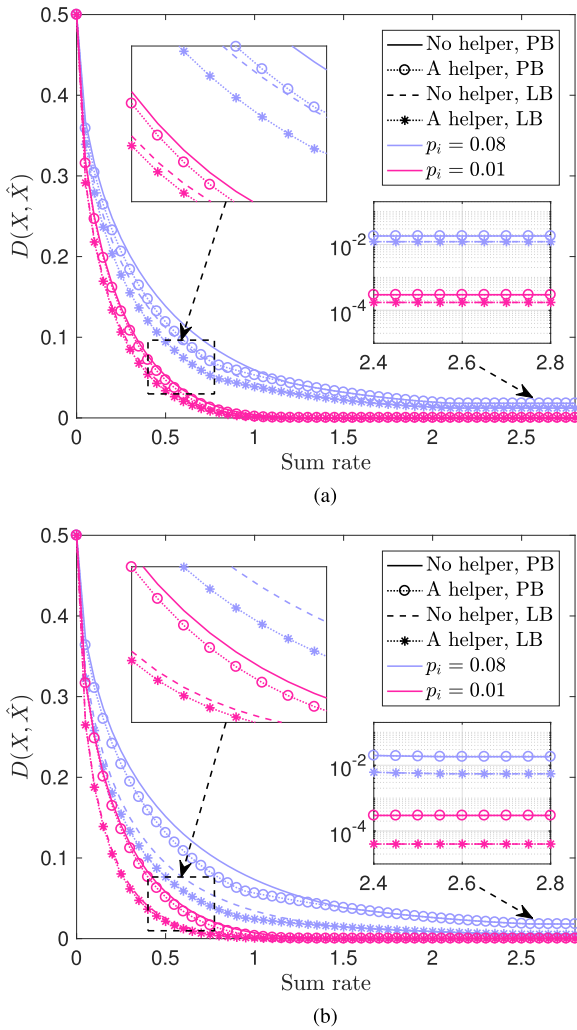

FIGURE 6. The trade-off of rate-distortion with diverse number of agents. (a) $L = 3$. (b) $L = 4$.

Regarding the helper sequence Y^n , since its optimal structure is still an open problem, we select two frequently implemented structures in practice as $g(\cdot)$, i.e., the helper information generated by modulo-2 sum or majority voting. The $g(\cdot)$ by modulo-2 sum is illustrated in Fig. 8, where X_i^n is interleaved by $\Pi_{i,1}$ for the first step; subsequently, Y^n is

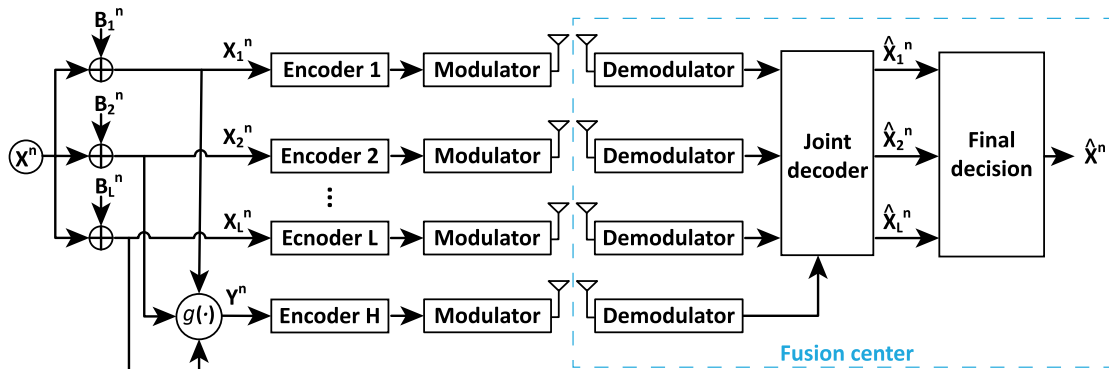

FIGURE 7. Simulation system.

produced by the modulo-2 sum of interleaved $X_{\mathcal{L}}^n$ bit by bit. By the interleaver $\Pi_{i,1}$, the distribution of Y is approximate to $\text{Bern}(0.5)$, i.e., Y^n can contain side information as much as possible.

Fig. 9 shows the structure of encoders. In order to better exploit the correlation among $X_{\mathcal{L}}^n$, the interleaver $\Pi_{i,1}$ is used to disperse noises into different bits of X_i^n . Subsequently, the interleaved X_i^n is outer-encoded with a convolutional code (CC). For the purpose of utilize the principle of turbo code [22] in decoding, an accumulator (ACC) [23] inner-encodes the interleaved outer code processed by another interleaver $\Pi_{i,2}$. For the helper, only one interleaver Π_H is needed between CC and ACC.

The general structure of joint decoder is depicted in Fig. 10. A decoder of ACC (ACC^{-1}) and a decoder of CC (CC^{-1}) decode inner code and outer code, respectively. In local iteration, the extrinsic information is exchanged between ACC^{-1} and CC^{-1} via an interleaver Π and its corresponding deinterleaver Π^{-1} . After several rounds of local iteration, the CC^{-1} outputs *a posteriori* log-likelihood ratio (LLR^p) of information bits. In global iteration, an extrinsic information exchanger updates *a priori* LLR^a with the extrinsic LLR^e , which is calculated by $(\text{LLR}^p - \text{LLR}^a)$. The joint decoder alternately executes local iteration and global iteration, until the mutual information calculated from LLR_i^p is large enough or the maximum iteration time is exceeded. Finally, the estimate of X_i^n is produced by the hard decision of LLR_i^p in the last round of local iteration.

The extrinsic information exchanger updates the LLR^a according to the rules shown in Fig. 11. For the case with helper information generated by modulo-2 sum, the LLR^e of all agents and the helper is first exchanged based on the same principle for the check node of low-density parity-check (LDPC) codes [24], as

$$\text{LLR}_i^{\text{tmp}} = \text{LLR}_i^e - 2 \arctanh \left(\prod_{j \in \mathcal{W}} \tanh \frac{-\text{LLR}_j^e}{2} \cdot \tanh \frac{-\text{LLR}_H^e}{2} \right), \quad (36)$$

$$\text{LLR}_H^a = \text{LLR}_H^e - 2 \arctanh \left(\prod_{i \in \mathcal{L}} \tanh \frac{-\text{LLR}_i^e}{2} \right), \quad (37)$$

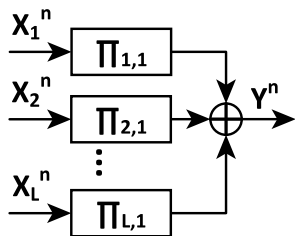

FIGURE 8. Generation of helper information by modulo-2 sum.

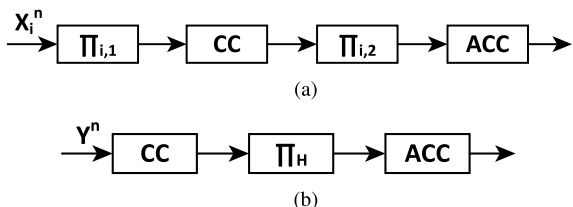

FIGURE 9. The structure of encoders. (a) Agent encoder i . (b) Helper encoder H .

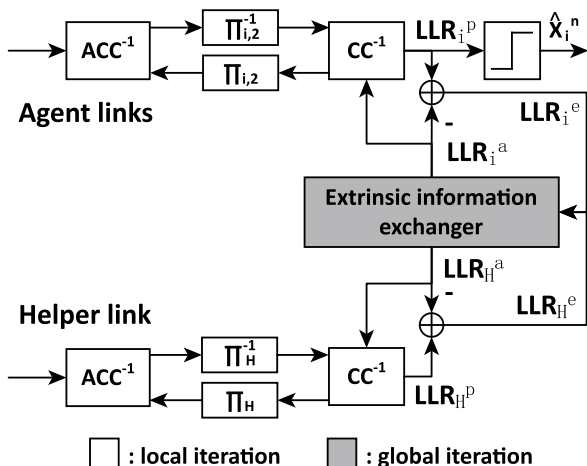

FIGURE 10. The structure of joint decoder.

where $\mathcal{W} = \mathcal{L} \setminus i$, and LLR_i^{tmp} is the temporary result for agents. Then, according to the correlation model [25], the LLR_i^{tmp} is deinterleaved by $\Pi_{i,1}^{-1}$ and further calculated by the LLR updating function $\mu(\cdot)$ for correlated source [26]. Finally, $\Pi_{i,1}$ interleaves the output of $\mu(\cdot)$ again to provide LLR_i^a . The structure of extrinsic information exchanger is much simpler for $g(\cdot)$ being majority voting. As illustrated in Fig. 11(b), $\mu(\cdot)$ directly updates all of the LLR_i^e after deinterleaving with the LLR_H^e , and then the outputs from $\mu(\cdot)$ for agents are interleaved into LLR_i^a .

B. SIMULATION RESULTS

Fig. 12 compares the simulation results between $g(\cdot)$ being modulo-2 sum (M2S) and majority voting (MV), where the basic parameter settings are listed in Table 1. Since the majority voting decision rule is implemented in simulations, we use the limit derived from Poisson binomial as the theoretical bound. Clearly, the trade-off of rate-distortion in simulations

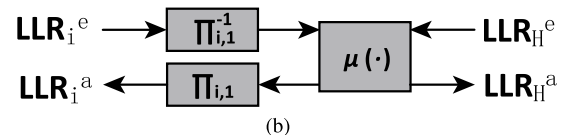
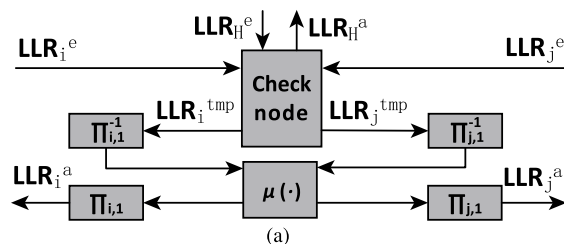

FIGURE 11. The structure of extrinsic information exchanger. (a) The helper information is generated by modulo-2 sum, where $i, j \in \mathcal{L}$ and $i \neq j$. (b) The helper information is generated by majority voting.

TABLE 1. Basic settings of simulation parameters.

Parameter	Value
Number of Blocks	1000
Block length	10000 bits
Distribution of X	Bern(0.5)
Generator polynomial of CC	$G = ([3, 2]3)_8$
Rate of CC	1/2
Type of interleaver	random interleaver
Modulation method	BPSK
Maximum iteration time	30

perfectly matches that in theoretical analysis, i.e., a helper can shift the turbo cliff to left but cannot reduce the BER floor. It should be highlighted that shifting SNR to left also means eliminating distortions for low SNR level. Moreover, the helper with $g(\cdot)$ being majority voting can obviously reduce the SNR threshold more than the helper which generates its information by modulo-2 sum. The reason for the difference of performance is that the distortion is included in the helper sequence with modulo-2 sum operation if there is only one check node. If one of the LLR_i is with the opposite sign, all of the other $(L - 1)$ LLR_i will get negative helper information. However, such negative helper information cannot be reversed again as in the LDPC codes, because no other check nodes exist in the system with only one helper. Hence, if the SNR is in an extremely low level, the helper with $g(\cdot)$ being modulo-2 sum will lose its effect due to the large distortion of X_i . This problem also results in the reduction of helper efficiency for large L , i.e., it is difficult to shift the turbo cliff by further increasing L . Therefore, the system with only one helper for $g(\cdot)$ being modulo-2 sum cannot obtain enough gains as the LDPC codes with a lot of check nodes. Nevertheless, the helper with its information generated by majority voting still can obviously reduce the SNR threshold with larger L . Because not only can the helper information generated by majority voting preserve large enough mutual

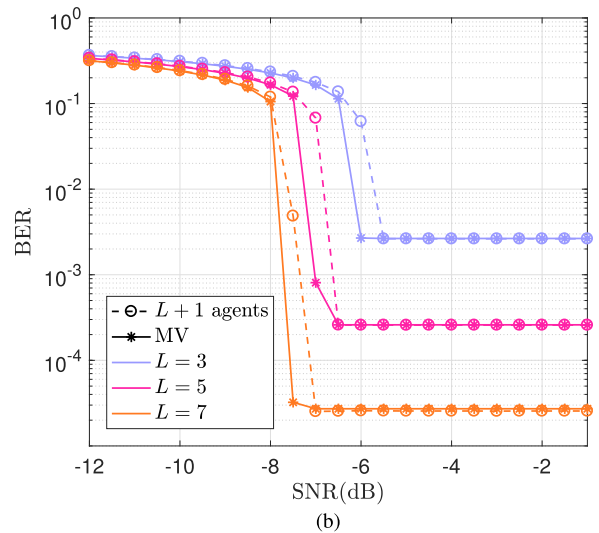
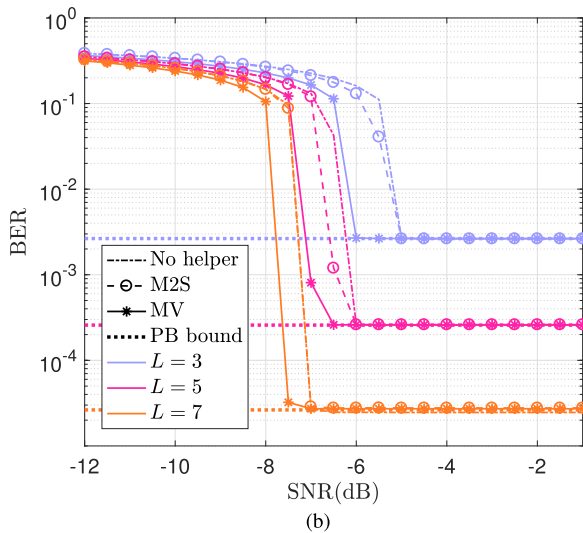
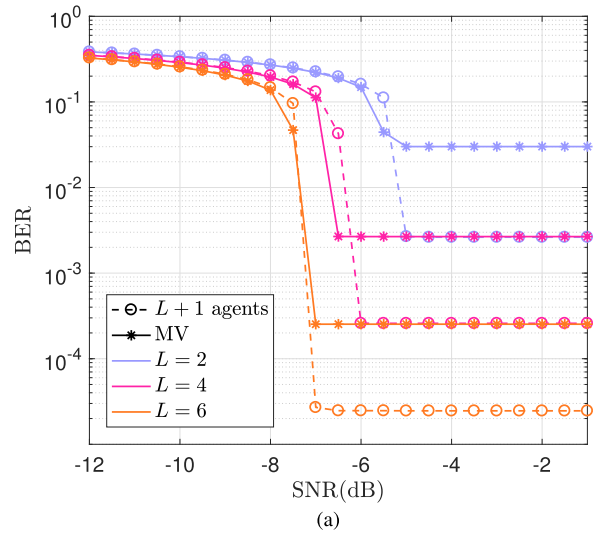
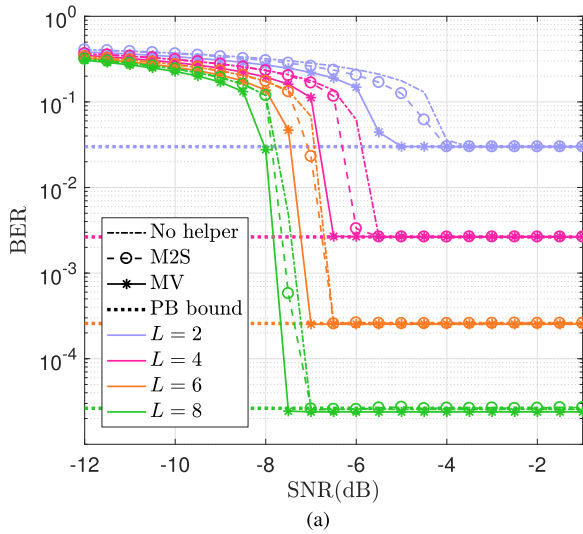

FIGURE 12. Comparison of simulation results between different structures of helper, where $p_i = 0.03$. (a) L is even. (b) L is odd.

FIGURE 13. Comparison between one additional agent and a helper, where $p_i = 0.03$. (a) L is even. (b) L is odd.

information among $X_{\mathcal{L}}$ for lower error-corrupted probability p_i , but the distortions occurring at the small part of nodes are also not dominant when exchanging extrinsic information. Besides, the simulation results for both structures of helper can achieve the bound derived from Poisson binomial process. Hence, we can draw a conclusion that it is convincible and effective to predict the trade-off of rate-distortion for a practical system by applying the theoretical results.

Finally, we make a comparison between $(L + 1)$ agents and a helper for diverse p_i as illustrated in Fig. 13 and Fig. 14. Since majority voting shows a better performance than modulo-2 sum as the helper structure, we only plot the curves of majority voting for comparison. It is remarkable in Fig. 13(a) and Fig. 13(b) that the system with $(L + 1)$ agents can achieve the BER floor of the case with $(L + 2)$ agents, when L is an even number. Because one additional agent provides extra information of X , and this avoids the draw case

that equal number of “0” and “1” appear in the same bit of agent sequences when L is even. However, the system with a helper has a lower SNR threshold for arbitrary L , due to the larger mutual information between Y^n and $X_{\mathcal{L}}^n$ by majority voting. Especially when p_i becomes larger or L is odd, the gap of turbo cliff between $(L + 1)$ agents and a helper is very conspicuous. We can also find that the system with $(L + 1)$ agents keeps the same BER floor as one-helper system when L is odd, even though one more agent provides extra mutual information about X . Consequently, except the additional implementation cost needed, it is better to add a helper than one more agent for a system with odd number of agents. If the wireless channels are good enough, one more agent can make the estimate of source more accurate for the system already having even number of agents. However, in an extremely noisy environment, i.e., before achieving BER floor and/or p_i is relatively large, the system performance can benefit more

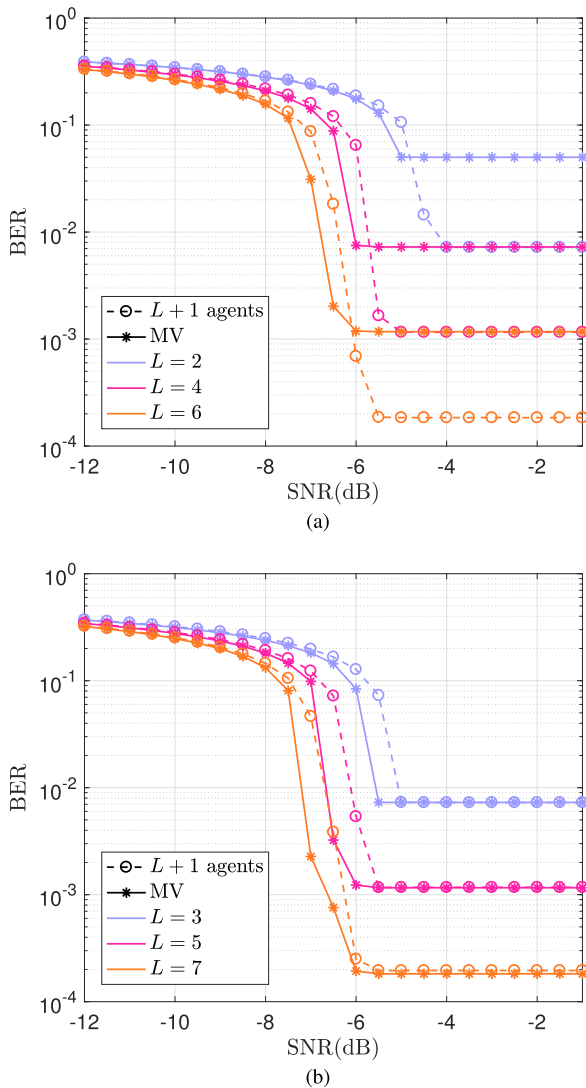

FIGURE 14. Comparison between one additional agent and a helper for more independent sources, where $p_i = 0.05$. (a) L is even. (b) L is odd.

from a helper than adding an additional agent. In addition, there is another noticeable phenomenon that the BER floor is not immediately achieved for relatively larger p_i and L after turbo cliff appears. Because for the bits at the same time index, they need to obtain enough extrinsic information from each other, so as to decode correctly when SNR is extremely low. Hence, only the bits almost without corrupting errors can accumulate their extrinsic information and be correctly decoded. The SNR threshold decreases as the number of agents increases, while larger SNR is required for large p_i to correctly decode all bits at the same time index. Once the SNR threshold decreases to the level in which the bits with some corrupting errors decode fail, the BER is not able to achieve the BER floor as soon as the turbo cliff appears.

V. CONCLUSION

We have analyzed and evaluated the performance of binary data gathering with a helper in IoT. To begin with, we

formulate binary data gathering with a helper in IoT as a binary CEO problem with a helper. Then, we decompose the binary CEO problem with a helper into two sub problems as multiterminal source coding with a helper and final decision. Subsequently, we derive an outer bound on the rate-distortion function for the multiterminal source coding step and the DPF for the final decision step. Based on the derived outer bound, a convex optimization problem is formulated to minimize the distortion of observations with given agent and helper link rates. By substituting the minimized distortions into DPF, we investigate the relationship between link rates and final distortion. Although there is an obvious gap between majority voting and optimal decision, they show the same tendency on the trade-off of rate-distortion. Finally, we have risen an encoding/decoding scheme and design a simulation for practical performance evaluation, so as to compare with the theoretical results and analyze the trade-off of rate-distortion for binary data gathering with a helper in IoT. Both the theoretical and simulation results indicate that a helper can reduce the SNR threshold, while the BER floor does not change. Moreover, a helper with its structure as majority voting has a better performance than an additional agent for the system with odd number of agents or in extremely noisy communication environment. These significant observations are extremely useful for the design of practical systems.

APPENDIX

ERROR PROBABILITY BY WEIGHTED MAJORITY VOTING

Regarding the error probability by weighted majority voting, the final decision \hat{x} follows [27]:

$$\hat{x} = \begin{cases} 1, & \text{if } \mathbf{wz}^T > 0, \\ 0, & \text{otherwise,} \end{cases} \quad (38)$$

where $\mathbf{w} = [\log \frac{1-p_1}{p_1}, \dots, \log \frac{1-p_L}{p_L}]$ and $\mathbf{z} = 2 \cdot [\hat{x}_1, \dots, \hat{x}_L] - 1$. Similarly to the Poisson binomial process, the error probability for the estimate of x is given by

$$p_e = \Pr \left\{ \sum_{k \in \mathcal{Z}_+} w_k > \sum_{j \in \mathcal{Z}_-} w_j \right\} + \frac{1}{2} \Pr \left\{ \sum_{k \in \mathcal{Z}_+} w_k = \sum_{j \in \mathcal{Z}_-} w_j \right\}, \quad (39)$$

where $\mathcal{Z}_+ = \{i|z_i = +1\}$ and $\mathcal{Z}_- = \{i|z_i = -1\}$. Note that in order to calculate (39), it needs to carry out the search over all the possible combinations of w_i .

REFERENCES

- [1] T. Berger, Z. Zhang, and H. Viswanathan, "The CEO problem," *IEEE Trans. Inf. Theory*, vol. 42, no. 3, pp. 887–902, May 1996.
- [2] P. Ostovari, J. Wu, and A. Khreishah, "Cooperative Internet access using helper nodes and opportunistic scheduling," *IEEE Trans. Veh. Technol.*, vol. 66, no. 7, pp. 6439–6448, Jul. 2017.
- [3] S. Gharehlooo and A. Sezgin, "Latency-limited broadcast channel with cache-equipped helpers," *IEEE Trans. Wireless Commun.*, vol. 16, no. 7, pp. 4192–4203, Jul. 2017.
- [4] A. Irawan and T. Matsumoto, "Feedback-assisted correlated packet transmission with a helper," *IEEE Trans. Veh. Technol.*, vol. 67, no. 5, pp. 4303–4315, May 2018.

- [5] K. Cao, Y. Wu, Y. Cai, and W. Yang, "Secure transmission with aid of a helper for MIMOME network having finite alphabet inputs," *IEEE Access.*, vol. 5, pp. 3698–3708, Feb. 2017.
- [6] X. He, X. Zhou, P. Komulainen, M. Juntti, and T. Matsumoto, "A lower bound analysis of Hamming distortion for a binary CEO problem with joint source-channel coding," *IEEE Trans. Commun.*, vol. 64, no. 1, pp. 343–353, Jan. 2016.
- [7] X. He, X. Zhou, M. Juntti, and T. Matsumoto, "A rate-distortion region analysis for a binary CEO problem," in *Proc. IEEE 83rd Veh. Technol. Conf. (VTC Spring)*, Nanjing, China, May 2016, pp. 1–5.
- [8] A. Razi and A. Abedi, "Convergence analysis of iterative decoding for binary CEO problem," *IEEE Trans. Wireless Commun.*, vol. 13, no. 5, pp. 2944–2954, May 2014.
- [9] J. Haghghat, H. Behroozi, and D. V. Plant, "Iterative joint decoding for sensor networks with binary CEO model," in *Proc. IEEE 9th Workshop Signal Process. Adv. Wireless Commun. (SPAWC)*, Recife, Brazil, Jul. 2008, pp. 41–45.
- [10] R. Ahlswede and J. Körner, "Source coding with side information and a converse for degraded broadcast channels," *IEEE Trans. Inf. Theory*, vol. IT-21, no. 6, pp. 629–637, Nov. 1975.
- [11] A. D. Wyner and J. Ziv, "The rate-distortion function for source coding with side information at the decoder," *IEEE Trans. Inf. Theory*, vol. IT-22, no. 1, pp. 1–10, Jan. 1976.
- [12] D. Slepian and J. K. Wolf, "Noiseless coding of correlated information sources," *IEEE Trans. Inf. Theory*, vol. IT-19, no. 4, pp. 471–480, Jul. 1973.
- [13] T. Berger, "Multiterminal source coding," in *The Information Theory Approach to Communications*, G. Longo, Ed. New York, NY, USA: Springer-Verlag, 1978, pp. 171–231.
- [14] S. Y. Tung, "Multiterminal source coding," Ph.D. dissertation, School Elect. Eng., Cornell Univ., Ithaca, NY, USA, 1978.
- [15] A. B. Wagner and V. Anantharam, "An improved outer bound for multiterminal source coding," *IEEE Trans. Inf. Theory*, vol. 54, no. 5, pp. 1919–1937, May 2008.
- [16] X. He, X. Zhou, M. Juntti, and T. Matsumoto, "Data and error rate bounds for binary data gathering wireless sensor networks," in *Proc. IEEE 16th Int. Workshop Signal Process. Adv. Wireless Commun. (SPAWC)*, Stockholm, Sweden, Jun. 2015, pp. 505–509.
- [17] X. Zhou, M. Cheng, X. He, and T. Matsumoto, "Exact and approximated outage probability analyses for decode-and-forward relaying system allowing intra-link errors," *IEEE Trans. Wireless Commun.*, vol. 13, no. 12, pp. 7062–7071, Dec. 2014.
- [18] P.-S. Lu, X. Zhou, K. Anwar, and T. Matsumoto, "Joint adaptive network-channel coding for energy-efficient multiple-access relaying," *IEEE Trans. Veh. Technol.*, vol. 63, no. 5, pp. 2298–2305, Jun. 2014.
- [19] C. E. Shannon, "A mathematical theory of communication," *Bell Syst. Tech. J.*, vol. 27, no. 3, pp. 379–423, Jul. 1948.
- [20] C. E. Shannon, "Coding theorems for a discrete source with a fidelity criterion," *IRE Nat. Conv. Rec.*, vol. 4, pp. 142–163, Mar. 1959.
- [21] A. El Gamal and Y.-H. Kim, *Network Information Theory*. Cambridge, U.K.: Cambridge Univ. Press, 2011.
- [22] C. Berrou and A. Glavieux, "Near optimum error correcting coding and decoding: Turbo-codes," *IEEE Trans. Commun.*, vol. 44, no. 10, pp. 1261–1271, Oct. 1996.
- [23] K. Anwar and T. Matsumoto, "Accumulator-assisted distributed turbo codes for relay systems exploiting source-relay correlation," *IEEE Commun. Lett.*, vol. 16, no. 7, pp. 1114–1117, Jul. 2012.
- [24] R. G. Gallager, "Low-density parity-check codes," *IRE Trans. Inf. Theory*, vol. 8, no. 1, pp. 21–28, Jan. 1962.
- [25] J. Garcia-Frias and Y. Zhao, "Near-Shannon/Slepian-Wolf performance for unknown correlated sources over AWGN channels," *IEEE Trans. Commun.*, vol. 53, no. 4, pp. 555–559, Apr. 2005.
- [26] X. Zhou, X. He, K. Anwar, and T. Matsumoto, "GREAT-CEO: Large scale distributed decision making techniques for wireless chief executive officer problems," *IEICE Trans. Commun.*, vol. 95, no. 12, pp. 3654–3662, Dec. 2012.
- [27] X. He, *Binary Information Sensing and Multiterminal Source Coding: Rate-Distortion Analysis and Transmission Design*. Nomi, Japan: JAIST Press, 2016.



WENSHENG LIN (S'17) received the B.Eng. degree in communication engineering and the M.Eng. degree in electronic and communication engineering from Northwestern Polytechnical University, Xi'an, China, in 2013 and 2016, respectively. He is currently pursuing the Ph.D. degree with the School of Information Science, Japan Advanced Institute of Science and Technology, Ishikawa, Japan. His research interests include network information theory, distributed source coding, helper structure design, and optimal encoding/decoding design.

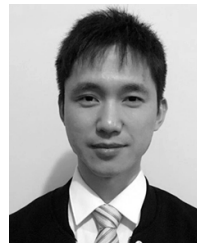

XIN HE received the M.Sc. degree in information science from the School of Information Science, Japan Advanced Institute of Science and Technology (JAIST), Ishikawa, Japan, in 2013, and the Ph.D. degree from JAIST and the University of Oulu, Oulu, Finland, in 2016. He is currently an Associate Professor with the School of Computer and Information, Anhui Normal University. He is also a Postdoctoral Researcher with the School of Computer Science and Technology, University of Science and Technology of China, Hefei, China. His research interests include joint source-channel coding, cooperative wireless communications, network information theory, energy harvesting, and backscatter communications.



MARKKU JUNTTI (S'93–M'98–SM'04) received the M.Sc. and Dr.Sc. degrees in electrical engineering from the University of Oulu, Oulu, Finland, in 1993 and 1997, respectively.

He was with the University of Oulu, from 1992 to 1998. From 1994 to 1995, he was a Visiting Scholar with Rice University, Houston, TX, USA. From 1999 to 2000, he was a Senior Specialist with Nokia Networks. He has been a Professor of communications engineering with the Centre for Wireless Communications (CWC), University of Oulu, since 2000, where he leads the Communications Signal Processing Research Group. He also serves as the Head of CWC–Radio Technologies Research Unit. He is also an Adjunct Professor with the Department of Electrical and Computer Engineering, Rice University. He has authored or co-authored some 350 papers published in international journals and conference records and in books *WCDMA for UMTS and Signal Processing Handbook*. His research interests include signal processing for wireless networks, and communication and information theory.

Dr. Juntti was the Chairman of the IEEE Communication Society Finland Chapter, from 2000 to 2001. He has been the Co-Chair of the Technical Program Committee of, 2004, Nordic Radio Symposium and, 2006, IEEE International Symposium on Personal, Indoor and Mobile Radio Communications, and the General Chair of, 2011, IEEE Communication Theory Workshop. He has served as a Co-Chair of the Signal Processing for Communications Symposium of GLOBECOM, 2014, Signal Processing for Communications Symposium and IEEE GlobalSIP, 2016, Symposium on Transceivers and Signal Processing for 5G Wireless and mm-Wave Systems, and ACM NanoCom, 2018. He was an Associate Editor for the IEEE TRANSACTIONS ON VEHICULAR TECHNOLOGY, from 2002 to 2008. He is an Editor of the IEEE TRANSACTIONS ON COMMUNICATIONS. He was a Secretary of the IEEE Communication Society Finland Chapter, from 1996 to 1997. He has been a Secretary of the Technical Program Committee of the, 2001, IEEE International Conference on Communications.



TAD MATSUMOTO (S'84–SM'95–F'10) received the B.S. and M.S. degrees, under the mentorship by Prof. S.-I. Takahashi, and the Ph.D. degree, under the supervision of Prof. M. Nakagawa, from Keio University, Yokohama, Japan, in 1978, 1980, and 1991, respectively, all in electrical engineering.

He joined Nippon Telegraph and Telephone Corporation (NTT), in 1980. Since, he been engaging in NTT, where he was involved in a lot of research and development projects, all for mobile wireless communications systems. In 1992, he transferred to NTT DoCoMo, where he researched Code-Division Multiple-Access techniques for mobile communication systems. In 1994, he transferred to NTT America, Inc., where he served as a Senior Technical Advisor of a joint project between NTT and NEXTEL Communications. In 1996, he returned to NTT DoCoMo, where he served as the Head of the Radio Signal Processing Laboratory, until 2001. He worked on adaptive signal processing, multiple-input multiple-output turbo signal detection, interference cancellation, and space-time coding techniques for broadband mobile communications. In 2002, he moved to the University of Oulu, Finland, where he served as a Professor with the Centre for Wireless Communications. In 2006, he served as a Visiting Professor with the Ilmenau University of Technology, Ilmenau, Germany, funded by the German MERCATOR Visiting Professorship Program. Since 2007, he has been serving as a Professor with the Japan Advanced Institute

of Science and Technology, Japan, while also keeping a cross-appointment position at the University of Oulu.

He has led a lot of projects funded by the Academy-of-Finland, European FP7, and Japan Society for the Promotion of Science and by Japanese private companies.

Prof. Matsumoto is a Fellow of IEEE and a member of IEICE. He has been appointed as a Finland Distinguished Professor from 2008 to 2012, funded by the Finnish National Technology Agency (Tekes) and Finnish Academy, under which he preserves the rights to participate in and apply to European and Finnish national projects. He was a recipient of the IEEE VTS Outstanding Service Award, in 2001, the Nokia Foundation Visiting Fellow Scholarship Award, in 2002, the IEEE Japan Council Award for Distinguished Service to the Society, in 2006, the IEEE Vehicular Technology Society James R. Evans Avant Garde Award, in 2006, and the Thuringen State Research Award for Advanced Applied Science, in 2006, the 2007 Best Paper Award of Institute of Electrical, Communication, and the Information Engineers of Japan, in 2008, the Telecom System Technology Award by the Telecommunications Advancement Foundation, in 2009, the IEEE COMMUNICATION LETTERS Exemplary Reviewer, in 2011, the Nikkei Wireless Japan Award, in 2013, the IEEE VTS Recognition for Outstanding Distinguished Lecturer, in 2016, and the IEEE TRANSACTIONS ON COMMUNICATIONS Exemplary Reviewer, in 2018. He has been serving as the IEEE Vehicular Technology Distinguished Speaker, since 2016.

• • •