

# Spectrum Gap Analysis With Practical Solutions for Future Mobile Data Traffic Growth in Malaysia

**IBRAHEEM SHAYEA<sup>1</sup>**, **MARWAN HADRI AZMI<sup>1</sup>**, **THAREK ABD. RAHMAN<sup>1</sup>**, **MUSTAFA ERGEN<sup>2</sup>**, **CHUA TIEN HAN<sup>1</sup>**, AND **ARSANY ARSAD<sup>1</sup>**

<sup>1</sup>Wireless Communication Centre, School of Electrical Engineering, Faculty of Engineering, Universiti Teknologi Malaysia, Johor Bahru 81310, Malaysia

<sup>2</sup>Electronics and Communication Engineering Department, Faculty of Electrical and Electronics Engineering, Istanbul Technical University, 34467 Sanyer, Turkey

Corresponding author: Ibraheem Shayea (ibr.shayea@gmail.com)

This work was supported by the Universiti Teknologi Malaysia under Grant R.J130000.7823.4J216 and Grant Q.J130000.2423.03G79.

**ABSTRACT** In this paper, an efficient spectrum forecasting model is developed to estimate the required spectrum and calculate the spectrum gap in future. This developed model is essentially based on five main metrics and one constant. The five main metrics are the currently available spectrum, sites number growth, data traffic growth, average network utilization, and spectrum efficiency growth. The constant metric is considered to give a space for our model to be used in another country or when a new technology is coming. This developed model is then used to forecast the required spectrum and spectrum gap for Malaysia in 2020. The estimation is performed based on the input market data of four main mobile telecommunication operators in Malaysia: Maxis, Celcom, Digi, and U-Mobile. The input data for this model are collected from various sources, such as the Malaysian Communications and Multimedia Commission, OpenSignal, Analysys Mason, GSMA, and HUAWEI. The results indicate that by 2020, Malaysia will require around 307 MHz of additional spectrum to fulfill the enormous increase of mobile data demands. Addressing this increment can be achieved by launching additional spectrum bands, enhancing spectrum efficiency, off-loading mobile data to unlicensed bands or deploying more site numbers.

**INDEX TERMS** Mathematical forecasting spectrum model, forecasting required spectrum, spectrum gap, Malaysia's spectrum in future.

## I. INTRODUCTION

In the past several years, the use of mobile data services has broadly and rapidly increased, becoming an essential and necessary addition in the lives of most mobile cellular users [1], [2]. Mobile data services are widely used by users, Internet-of-Things (IoT) applications [3]–[14], and Machine-to-Machine (M2M) connections [15]–[23]. The reason for this massive growth is due to several factors that effectively contribute to increasing mobile data demands. One of the main factors include the massive and diverse developments of new portable devices such as smart phones, tablets, laptops, e-book readers, gaming consoles and dongles [24], [25]. They have led to the evolution of various mobile applications, which cover numerous areas of a user's life; e.g. the social,

educational, information, news, science, health, trading, etc. Most mobile applications must have connection to the internet to be fully functional, which leads to an increase in mobile data demands. In addition, the escalation of video streaming (which has become an effectively employed tool for life learning, news, entertainment and other purposes) further leads to increased mobile data demands. The rapid growth of IoT applications and M2M connections are two other effective factors that contribute to additional mobile data demands [2], [15], [26]–[30]. The IoT was titled as the upcoming industrial revolution in mobile telecommunication systems. It has begun to significantly grow and will influence the way businesses and customers interact with the physical world [2], [27], [31]–[36]. Similarly, M2M is also noticeably growing [16], [37]; Machina Research predicted that worldwide M2M connections will expand from five to 27 billion between the years 2014 and 2024, with the Compound

The associate editor coordinating the review of this manuscript and approving it for publication was Jad Nasreddine.

Annual Growth Rate (CAGR) of 18% [38]. Thus, in the next five years, IoT applications and M2M connections will be the largest market worldwide. With the significant expansion of mobile connections, mobile applications, IoT applications and M2M connections, there is the forthcoming requirement for new mobile telecommunication systems to permit a straightforward connection to the system for every single user, including high-performance quality for all services. This massive exposure will widen the scope of mobile applications and all mobile services to be rapidly shared, generating a remarkable upgrade to the Mobile Broadband (MBB) experience. This, in turn, will boost the number of customers who access mobile telecommunication systems, creating a further need for larger economies of scale, as well as, lesser prices per bit. As several business models arise with various advertising methods (media) and mobile services with M2M connections, augmented reality and live gaming, an equally useful circumstance should be developed for mobile service providers. New organisations, ecosystems and strategic associations are predictable as mobile operators, mobile application developers and others try to adapt to the video activities that pass through mobile telecommunication networks. Operators must solve the issue of efficiently monetising video activity while expanding infrastructure capital expenditures. They must further be active and capable of quickly changing courses, while delivering innovative services to involve new mobile applications and services for customers. As the unhindered internet administrative procedures and operators' business models expand, there is the neglected customer requests for higher connections, download speeds and peak quality. Currently, mobile telecommunication technologies aim to offer experiences formerly accessible only through wired networks, however, the following few years will be crucial for regulators, operators and mobile service providers to strategize the future spectrum for mobile telecommunication network deployments capable of fulfilling data demands. For that, implementing the next generations of mobile cellular networks, the Fifth Generation (5G) [39]–[42] and Sixth Generation (6G), will require more capacity and greater data rate to efficiently support all customer usage trends, enable massive IoT applications and M2M services [3], [43], [44], as well as, preserve mobile infrastructure prices within proper limits.

From this brief review, it can be concluded that the interest for MBB data will continue to grow in the near future. Although the rate of this growth is tough to determine, it can be predicted through the utilisation of developed forecasting models. These forecasting models provide an indication concerning mobile data growth and the required spectrum needed for the future [45]. Therefore, forecasting MBB Data Traffic Growth and the required licensed MBB spectrum will yield a valuable perception of the general trends in MBB growth. Furthermore, forecasting the mobile data traffic and licensed MBB spectrum is a significant tool that can be employed to direct regulators and mobile operators on the relevant strategies for tackling future demands of the forthcoming-required

spectrum and deploying the future MTNs. For that, several forecasting models were developed to predict mobile data traffic, and were then used to forecast the required licensed MBB spectrum. Some of the developed models used to forecast mobile data demands include the Delphi model [46], data translation model [47], combining time series models for forecasting [48], the Sungjoo Lee model [49], diffusion modelling [50] and trend extrapolation [50]. Analysys Mason [51] is one of the most expert in global analysis and consultative services in the telecommunications and technology market. They have conducted numerous prediction studies, especially for forecasting mobile data traffic, such as what has been accomplished in South East Asia [51]. GSMA [52] is also one of the trade bodies that universally exemplifies the interests of mobile operators. They performed several predictions; particularly, in mobile connection growth rates and data traffic. Another model was proposed by Kovács *et al.* [53] to mathematically forecast mobile broadband traffic. This model mainly depends on technological penetration and subscriber traffic growth. The technology penetration growth is modeled with the “S-curve” Gompertz function [54], while the subscriber traffic growth is modeled with the linear growth, or an exponential function. According to the licensed MBB spectrum, which is the main focus of this study, there are several models developed to forecast the future-required spectrum; for example, the ITU model [55]–[57], Federal Communications Commission (FCC) model [58], Plum Insight model [59], ACMA engaged Analysys Mason model [60] and Pyramid Research model [61]. All models were developed to forecast the future-required mobile broadband spectrum for different markets utilizing various input parameters and input data. Even though there are several models established to forecast the spectrum, no model can provide the exact amount of spectrum needed in future. Moreover, models have not consider all significant input metrics, and even then, the considered input parameters of each model are not always available for researchers in different countries. Therefore, new models must be developed, taking into account all significant input parameters and the availability of these input data, so that the developed model can efficiently predict (as much as possible) the required amount of spectrum.

Consequently, this paper aims to provide a perspective on forecasting spectrum models, and to forecast the required spectrum for Malaysia in 2020. An Efficient Spectrum Forecasting (ESF) model is introduced to estimate the required spectrum and to calculate the spectrum gap for future. The developed model is based on five main input metrics and one constant. The five main input metrics are the Current Available Spectrum (CAS), Sites Number Growth (SNG), Data Traffic Growth (DTG), Average Network Utilisation (ANU), and Spectrum Efficiency Growth (SEG). The constant metric is considered to give a space for our model to be used in another country or when a new technology is coming. That can be achieved by replacing the constant metric by significant parameters that can contribute for forecasting the

accurate spectrum in the future. This proposed model was used to estimate the required spectrum and the spectrum gap for Malaysia’s future. The estimation is performed based on the input market data of four main MTOs in Malaysia: MAXIS, CELCOM, DIGI and U-MOBILE. The input data for this model were collected from different resources, such as the MCMC, OpenSignal, Analysys Mason, GSMA, HUAWEI, etc. The results indicated that by 2020, Malaysia will require around 307 MHz of additional spectrum to fulfil the tremendous increase of data demands. Thus, an additional spectrum band should be found for Malaysia in 2020 in order to meet the data demands in that time. Addressing the increases of mobile broadband growth can be enabled by launching additional spectrum bands, enhancing spectrum efficiency, off-loading mobile data to unlicensed bands and deploying more site numbers.

The rest of this paper focused on the following: the research background and related works are discussed in Section II. The developed forecasting spectrum gap model is explained and discussed in Section III. The spectrum gap analysis is described in Section IV, followed by the recommendations and solutions in Sections V. Finally, the conclusion of this paper is discussed in Section VI.

**II. BACKGROUND AND RELATED WORKS**

Wireless connectivity is the platform for innovation in the 21<sup>st</sup> century, and the spectrum is the backbone for wireless services. The spectrum is a limited and non-renewable resource; its use is usually controlled by the federal government or regulators. The regulators normally find the required and suitable spectrum bands, then divide them equally between operators. The required spectrum mainly depends on the demand for mobile data, which is radically and continuously increasing in the last few years [57], [61]–[64]. With current predictions, the total Global mobile data traffic will continue to significantly grow in future. According to ITU-R’s prediction, the Global mobile data traffic in 2020 will increase around four-times more than the data demand of 2015 [57]. In addition, CISCO predicted that the Global mobile data traffic growth in 2020 will increase around eight-times more than 2015 [62]. Another forecasting was performed by ERICSSON, which estimated that the Global mobile data traffic growth will increase nearly ten-times in 2021 compared to 2015 [65]. HUAWEI forecasted that the Global mobile data traffic growth by 2020 will increase around twenty-times more than 2015 [64]. In the South-East Asia and Oceania regions, ERICSSO predicted that mobile Data Traffic Growth will increase around fourteen-times more between the periods of 2015 and 2021 [66]. In the Asia Pacific regions, ERICSSO estimated that the increase in mobile data traffic will be eleven-times more between the periods of 2014 and 2020 [63]. As predicted by CISCO, by 2020, mobile data traffic for Asia Pacific regions will increase almost nine-times more than what was needed in 2015 [62]. Additional estimation was performed by Pyramid Research, they estimated that the average mobile data

**TABLE 1. Mobile data traffic growth for different areas.**

Region	Growth Rate Multiplier				
	ITU	ERICSSON	HUAWEI	CISCO	Pyramid Research
South East Asia and Oceania	-	14x (2015-2021) [66]	-	-	-
Asia Pacific	-	11x (2014-2020) [63]	-	8.7x (2015-2020) [62]	-
Developing Asia	-	-	-	-	15.0x (2015-2020) [61].
Global	4-times [57]	10x (2015-2021) [65]	20x (2015-2020) [64]	8.3x (2015-2020) [62]	

\*Developing Asia is Bangladesh, Myanmar, Vietnam and Indonesia.

traffic for developing Asia countries (Bangladesh, Myanmar, Vietnam and Indonesia) will expand around fifteen-times more than 2015 [61]. In addition to mobile data traffic growth, the mobile video traffic, smartphones, tablets, mobile devices, smart devices and connections will further increase in the coming future years. CISCO [62] estimated that all these services will tremendously expand in 2020 as compared to 2015. To sum up all these predictions, Table 1 presented a brief outline regarding mobile data traffic growth for several regions based on various forecasters.

This huge increase of data demand is due to several factors. For example, the diversity of new portable devices contributes to the increase of mobile data traffic. In the last few years, several types of devices were launched; e.g., laptops, smart phones, e-book readers, tablets, gaming consoles and dongles. The advent of smart and diverse devices contributes to the massive increase of mobile applications. The most popular applications on mobile devices include the news, maps, social networking, music and, most recently, medical and various IoT applications which have actually captured users’ attention. There are several types of mobile applications introduced by stakeholders, which are practically available on many online and application stores; that leading to the revolution of a new market. Most of the applications are closely planned with the aim of getting users to be connected; thus, mixing the use of mobile data. This leads to the enormous increase in the use of mobile internet. Essentially, mobile users always want to stay connected and they are expected to consistently employ the internet for several frequently-used applications. In addition, the new applications provided by stakeholders require the use of the internet in terms of downloading purposes which, in turn, increases the mobile data traffic.

The growing trend of mobile video traffic is also one of the contributing factors of increasing mobile data traffic. Video sharing apparently emerged as a new option for customers to possess audio-visual content. In the past few years, consuming a video does not only involve the act of watching it, but sharing it with others, having the access to comment on it, include it in blogs, etc. Thus, the online video market

has been dominated by community-based sites. Nowadays, sharing videos is easier, whereby, users have access to others' profiles on social network by just clicking on the share button. Facebook is now a video viewing site, and it is estimated that in the future, the streaming of online videos will massively contribute to the growth of mobile traffic. Social Networks accessed through mobile devices is an additional trend that leads to increasing mobile data traffic. It has been observed that social networking sites have evolved to be the most popular sites employed by users for socialising; thus, increasing the growth of social networking applications available online. It is expected that social networking applications will continue to increase the use of mobile data in future due to the impact they have on users. Moreover, the integration of location-based functions with social networks further has an impact on the inclination of applying mobile data. Growing M2M traffic is one more factor that is expected to rise in the next few years. This is due to the demands of users concerning M2M applications and devices; and it is expected that applications will rapidly grow within the next few years, especially with the excessive growth of IoT. The 5G system aims to connect everything to the internet. The improvement in network-user experience is also an additional factor which contributes to increasing mobile data demands. Introduction to new high-bit rate mobile networks in the coming years is anticipated, where service bit-rates and reliability will also be improved. This will definitely enhance user experience when viewing contents online, and it might as well lead to the increase in the use of mobile data. Decreasing cost and prices is the key point for increasing mobile data demand. The next generation of mobile wireless systems may contribute to massive data traffic capacity, as well as, network flexibility; in this case, reducing operators' total cost in terms of deployment and operation of the network. When cost is reduced, operators may subsequently offer more affordable prices to users, such as introducing flat rate mobile data packages or fixed monthly fees, and provide the essential data access that users require. A multiple policy initiative in promoting the use of mobile broadband leads to the increase of mobile data traffic. The industry has been working on mobile broadband technologies for more than a decade. With current support from the administration, broadband services continue to provide benefits to users. The mobile broadband has been supported and promoted by administrations, in line with their national mobile plans; however, the United Nations (ITU/UNESCO) mentioned that there is the need for a new vision to reduce the regulatory burden, as well as, innovative incentives and coordinated efforts for unleashing opportunities to commercial deployments. Demographics of a broader user-age group also play a role for the ever-increasing mobile data traffic. The ages of users and how they utilize the internet has changed from how it was a few years back; thus contributing to the high demand for the internet. More elderly people have begun using the internet, and its use is further applied in schools for younger generations, starting from kindergarten onwards. Moreover, the potential area, such as

cloud, is also increasing data demand. The demand of mobile data services will definitely contribute to its growth since users are currently in need of mobile data for various aspects of their lives; certain services are always kept in use so that users can be constantly updated on what is happening around them. This will consequently increase the volume of mobile data traffic. Moreover, the multimedia services captured on mobile devices will overwhelmingly carry the greatest cloud computing and storage demands due to the revolution of new high resolution camera applications available on mobile devices [67]. In conclusion, the contributing factors for increasing mobile data traffic can be summarized as in the following:

- The diversity of new portable devices
- The massive increase of mobile applications
- The enormous increase in the use of mobile internet
- Radically expanding video traffic
- Social networks mostly accessed through mobile devices
- The rapid growth of IoT applications
- Growing Machine-To-Machine traffic
- Improvements in network-user experiences
- Decreasing costs and prices
- Multiple policy initiative in promoting the use of mobile broadband
- Demographics of a broader user-age group
- Potential area in increasing the data demand

All these factors mainly contribute to increasing mobile data traffic, which in turn, leads to the need for an exponentially wider spectrum. Even though some parts of this data demand can be fulfilled by implementing new technologies (off-load users to unlicensed systems, and guesswork in building additional networks), a licensed spectrum will further be needed to allow users to access the internet, applications, as well as, download the content at a relatively fast speed. The growth rate of this required spectrum is hard to determine, creating challenges for planning the implementation of mobile telecommunication networks, and for developing new mobile devices. Determining the required licensed MBB spectrum will present valuable knowledge concerning the general trend in MBB growth. This will provide an indication regarding the required spectrum needed in future. Therefore, forecasting the required licensed MBB spectrum becomes an essential part for planning and implementing future mobile telecommunication networks. For that, several research centres, industries and telecommunication development companies have created various spectrum forecasting models to predict the required licensed MBB spectrum for the future; as explained in the following paragraphs.

ITU-R developed a model to forecast the future spectrum gap. The developed model is available online in a Microsoft excel file at [55], while the details are explained clearly in M.1768-1 [55], M.2290 [56] and M.2077 [57]. The calculation steps were described in the ITU-R report numbered M.1768-1 [55]; along with the relevant input parameters (detailed descriptions of these parameters were provided in

M.1768-1 [55], M.2290 [56] and M.2077 [57]). The methodology begins with the market study which characterizes all traffic carried by IMT and other mobile systems (Steps 2 & 3). Next, the total traffic obtained from the market studies are distributed among different radio environments (cell layers) and Radio Access Technology Groups (RATGs) based on several factors such as traffic characteristics (required data rates and user motilities) and RATG capabilities (supported data rates, available cell types and their coverage) (Step 4). Subsequently, the system capacity required to carry the offered traffic is calculated using separate capacity calculation algorithms for reservation-based traffic and packet-based traffic, respectively (Step 5). Next, the initial spectrum estimates are obtained from the capacity requirements by dividing the latter by the spectral efficiencies (Step 6). Afterwards, adjustments are made to consider network deployments with the spectrum requirements being aggregated over the relevant deployments (Steps 7 & 8). Lastly, the overall spectrum requirements of RATG 1 and RATG 2 are produced as outputs, which collectively indicate IMT systems (Step 9). This model was published online as a Microsoft Excel file format in [68]. Consequently, the main algorithms employed in the ITU-R model include: (i) Traffic calculation algorithm, (ii) The traffic distribution algorithm, (iii) The capacity calculation algorithm and (iv) The spectrum requirement calculation algorithm. The details of these algorithms were described in M.2290 [56].

In 2010, the Federal Communications Commission (FCC) [58] proposed a model to predict the required spectrum for the years 2009 to 2015. The model forecasts the spectrum as the function of data traffic demand, site growth, spectral efficiency and spectrum utilization. The details of this proposed model were fully explained in [58]. The prediction procedure begins by estimating the data traffic per site based on the data traffic demand and site growth. This data traffic per site is then used with the spectral efficiency to predict data traffic per technology. Next, the spectrum utilization with the data traffic per technology are used to estimate the total future spectrum required. The FCC's model is employed to estimate the spectrum needs for the United States between the years 2009 and 2015. In 2015, CTIA - The Wireless Association, used the FCC's model to forecast the required spectrum for the United States between the years 2015 and 2019. The details of this forecast were explained in [69]. The results indicated that in the period of 2009 to 2019, the required spectrum for the United States will further increase.

In 2014, Plum Insight adopted an approach known as the bootstrap model to forecast data traffic and spectrum demand [59]. This model is mainly based on spectrum baseline, variance in spectrum, mobile data traffic and data price. The bootstrap model considers several assumptions in the input parameters; as illustrated in [59]. For example, the cost of customers' mobile data in 2030 is assumed to be the same as now, and the total number of mobile data users is assumed to drastically increase by around 50% of the total population. The estimation was performed based on three

different scenarios: the effect of different network capacities; the effect of different customer willingness to pay for mobile data; and the effect of varying site expenses over time. The bootstrap model is used to forecast data traffic and spectrum demands for Western Europe. The output estimated results by the bootstrap model [59] is also compared to another model known as the avoided cost model [70]; it demonstrated that the required spectrum for Western Europe will also radically increase.

In 2015, ACMA involved Analysys Mason to design a new mobile network infrastructure forecasting model to predict mobile data traffic and subsequently the required spectrum needed for Australia [60]. The model depends on three main metrics: the number of coverage sites, the capacity of each coverage site and forecasted traffic. The number of coverage sites is calculated based on the network coverage for each morphology and cell radius for each site. The capacity of each coverage site is evaluated as a function of spectral efficiency and the amount of spectrum available; while the forecasted traffic is computed as a function of subscriber number by technology, traffic per subscriber by technology, traffic per morphology and download, as well as, upload traffic. A result of the engagement between ACMA and Analysys Mason is to utilize the mobile network traffic forecasted by Analysys Mason [60], and other assumptions, on the availability of spectrum. The model estimates the total site numbers required for a given set of assumptions concerning network traffic, spectrum availability, spectral efficiency and coverage size. At the point when network traffic increases to the level that is causing congestion at certain sites, the proposed model assumes that the operator will normally react by finding any available carrier frequencies for use. The spectrum will then become available. The practical network parameters employed in the Analysys Mason model (for example, spectral efficiency and network traffic) are extremely variable and have a high degree of associated uncertainty. However, the step between a mobile network traffic forecast and a spectrum requirement forecast includes the introduction of another uncertainty (that is even more difficult to model): the commercial considerations that drive the decisions of mobile operators regarding their preferred combination of measures to satisfy their network capacity requirements and the impact on the broader economy.

In 2016, Pyramid Research developed another improved model to estimate the required spectrum in the coming years. The general description of the Pyramid Research model was detailed in [61]. This model is similar to the FCC model, whereby, it mainly depends on four input parameters: (i) mobile data traffic, (ii) wireless towers, (iii) spectral efficiency and (iv) wireless spectrum available. The estimation process begins by forecast the mobile data traffic per wireless tower, utilizing both mobile data traffic and wireless towers. Then, the mobile data traffic per wireless tower is used with the spectral efficiency to estimate mobile data traffic per technology. Subsequently, the mobile data traffic per technology with the available wireless spectrum

are then employed to forecast the total required wireless spectrum and spectrum gap for the next few years leading up to 2020. The year 2015 was used as the base year for their estimation. The prediction begins forecasting the mobile data traffic and, subsequently, the required spectrum. The estimation was performed for several countries, particularly for South East Asian countries such as Indonesia, Myanmar, Vietnam and Bangladesh. According to the results predicted by the Pyramid Research model, the total available spectrum of 2015 will eventually not be enough to fulfil the tremendous increase in mobile Data Traffic Growth. The number of wireless spectrums needed in 2020 is significantly higher for all countries considered. Some of them will even start experiencing a spectrum shortage in 2017, and other countries will begin having this deficiency during 2018.

Based on previous reviews, all presented models utilize several input parameters to predict the required spectrum for the future. Some of these models consider numerous parameters, while others consider only a few parameters to forecast the future-required spectrum. Some of these developed models are very complex, while others are more practical and easier to use; however, no one can 100% predict the exact spectrum required. The most popular model is the ITU model [55]–[57], which considers countless parameters to forecast the needed spectrum. This can be considered as an advantage since it will lead to more accurate results. However, this model does consist of very complex calculation processes with complicated input requirements, and it does not consider the site numbers or spectrum efficiency improvement/MBB technology improvement over time. The other developed models by FCC [58], Plum Insight [59], ACMA involved Analysys Mason [60] and Pyramid Research [61] seem more practical and usable compared to the ITU-R model. This is due to the reasonable input requirements, simpler calculation processes, as well as, being more realistic; taking into consideration significant input parameters such as site numbers, mobile data traffic and spectrum efficiency improvement/MBB technology improvement over time. Unfortunately, these models do not consider all significant input parameters; for example, ACMA involved Analysys Mason [60] does not take into account network utilization and spectrum efficiency, while FCC does not consider the available spectrum. Moreover, Plum Insight does not consider site numbers growth, network utilization and spectrum efficiency; and Pyramid Research [61] does not take into account the use of network utilization. The deficiency of significant input metrics will lead to the inaccurate forecasting of the required spectrum. This signifies that the existing forecasting spectrum models are not ideal for predicting the future-required spectrum. Furthermore, the availability of input data differs from country to country; for instance, the sites number in Malaysia can be collected from the MCMC annual report, while in other countries, it is difficult to find. This is another issue which can restrict the use of these developed models. As a result, it can be concluded that forecasting the future-required spectrum is continuously an open area for research and a new forecasting

model must be developed. It should be more efficient and comprehensive, taking into account the availability of input parameters, as well as, the suitable parameters in that specific country. Accordingly, the main aim of this study is to provide a perspective on the spectrum needed for Malaysia in 2020.

### III. THE FORECASTING SPECTRUM GAP MODEL

This section explains the proposed forecasting model to estimate the licensed spectrum required and spectrum gap for future use. To determine the need of the required spectrum for future mobile broadband, the first step is to analyze the drivers of mobile traffic demand and total available network capacity. The needs of the future spectrum will be mathematically defined as a function that consists of several multipliers, and the current spectrum used for mobile broadband nationwide. In this work, the multipliers are generated based on the metrics that contribute directly to either the mobile traffic demand or to the network capacity. In one hand, the traffic demand depends on data consumption by device type and the numbers of each device type in use, which contribute to the growth of mobile data traffic. Note that, positive growth to the mobile broadband traffic demands an additional spectrum. On the other hand, the network capacity can be understood as the amount of data a network can carry, which directly depends on spectral efficiency of wireless technologies (i.e. the amount of spectrum needed to transmit a given amount of data), available spectrum, utilization of the network and number of cell sites. Here improvement to any of these four input metrics will increase the network capacity, as a result, will reduce the need for additional spectrum. Thus, forecasting spectrum is mainly influenced by five input metrics, which are: SNG( $S_{fy}$ ), MDTG ( $M_{fy}$ ), ANU( $u_{cy}$ ), SEG( $\eta_{fy}$ ), and CAS( $w_{cy}$ ). These five main metrics are considered as input parameters due to their significance and crucial for producing an accurate assessment of the required spectrum. They have a direct influence on the required spectrum in future. The relationship between the forecasted spectrum and these five input metrics is summarized in Table 2, while the general description concerning our proposed model is shown in Figure 1.

**TABLE 2.** Relationship between the forecasted spectrum and the five input main metrics.

Input Metrics	Action	Forecasted Spectrum	Spectrum Gap
$S_f$	UP	DOWN	DOWN
$w_c$	UP	UP	UP
$M_f$	UP	UP	UP
$u_c$	UP	UP	UP
$\gamma_f$	UP	DOWN	DOWN

The first metric influencing the forecasted spectrum is the Sites Number Growth (SNG), which is known as the annual growing proportion of site numbers for MTOs. This growth contributes to the increase in the system capacity (fulfilling mobile data demands), in which indicates that the increase in SNG will provide higher throughput. That leads to a reduction

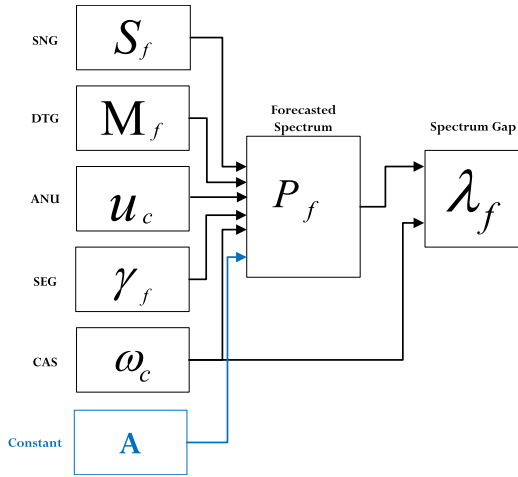

**FIGURE 1.** Proposed forecasting model to estimate the required spectrum and spectrum gap for future.

in the required spectrum; signifying that the required spectrum has an inverse relationship with the total sites' number. So, operators must keep on annually renewing, installing and upgrading their sites. Therefore, SNG is considered one of the significant metrics used to estimate the required spectrum in the proposed forecasting spectrum model. That means, the SNG is inversely proportional to the required spectrum as illustrated in Eq.1:

$$P_f \propto \frac{1}{S_f} \tag{1}$$

where,  $P_f$  and  $S_f$  denote the forecasted spectrum (required spectrum) and the SNG for the forecasted year “f”, respectively.

The second input metric influences the forecasted spectrum is the Mobile Data Traffic Growth (MDTG);  $M_f$ , which is always rapidly and radically expanding due to several factors; as previously illustrated in Section II. This tremendous increase leads to the escalation of spectrum requirements in the coming years. The new allocated spectrum bands are the most proper solution to meet this enormous surge in mobile data traffic. Therefore, considering mobile data traffic growth as an input metric through the forecasting of the required spectrum in future is crucial to producing an accurate assessment. Thus, mobile data traffic growth was considered one of the main metrics to forecast the required spectrum in the proposed forecasting spectrum model. Therefore, MDTG is directly proportional to the required spectrum, which means it also directly proportional to the forecasted spectrum in any year, “f”, as illustrated in Eq.2:

$$P_f \propto M_f \tag{2}$$

where,  $M_f$  denotes the MDTG for the forecasted year “f”.

The third metric influencing the forecasted spectrum is the Average Network Utilisation (ANU), which is used to measure the percentage of spectrum occupation. This metric is, for the most part, radically rising with the rapid boost

of mobile data demands. That causing linear increased in spectrum occupation, in which leads to a direct increase in the required spectrum. That indicates a direct proportional between the required spectrum and the ANU as illustrated in Eq.3:

$$P_f \propto u_c \tag{3}$$

where,  $u_c$  denotes the ANU for the current year “c”. Consequently, considering network utilization as an input parameter through the estimation of the required spectrum is highly significant as it will increase the forecast’s accuracy. Thus, average network utilization is one of the main considered metrics in the proposed forecasting spectrum model.

The fourth metric influencing the forecasted spectrum is the spectrum efficiency growth (SEG), which is one of the significant metrics that is normally enhanced when a new technology is coming, almost double than the previous technology; as illustrated in [66], [71], and [72]. This growth contributes to the surge in mobile data demands. That means spectrum efficiency growth contributes to reducing the required spectrum in future. That denotes the forecasted spectrum has an inverse relationship with spectrum efficiency. Therefore, considering spectrum efficiency growth as an input parameter through the estimation of the required spectrum is very important to make an accurate prediction. Thus, the forecasted spectrum is also inversely proportional to the SEG as illustrated in Eq.4:

$$P_f \propto \frac{1}{\eta_f} \tag{4}$$

where,  $\eta_f$  denotes the SEG for the forecasted year “f”.

The fifth metric influencing the forecasted spectrum is the Current Available Spectrum (CAS). This is because the growth ratio of the four main multipliers, SNG, MDTG, ANU and SEG, will be the percentage indicator of the forecasted spectrum over the CAS. That means, the required spectrum in future will be a multiplication of the four multipliers growth ratios by the CAS. Accordingly, this means the forecasted spectrum has a direct proportional with the ANU as illustrated in Eq.5:

$$P_f \propto w_c \tag{5}$$

where,  $w_c$  denotes the CAS for the current year “c”. In addition to that, the current available spectrum will be part of the total spectrum needed in future. Re-farming the current spectrum, especially the 2G spectrum band, to LTE and LTE-Advanced can be part of the solution for reducing the total required spectrum and spectrum gap in the following years. Accordingly, the current available spectrum is considered as one of the main metrics used to forecast the required spectrum in the proposed model.

Based on the direct and inverse relationships (from Eq.1 to Eq.5) of the five considered input metrics, the forecasted spectrum ( $P_f$ ) for any future year (f) is mathematically

formulated by Eq.6.

$$\mathcal{P}_f = \frac{\mathcal{M}_f \cdot \mathcal{U}_c}{\mathcal{S}_f \cdot \eta_f} \cdot \mathcal{W}_c \quad (6)$$

Since there is possibility for other significant metrics that can contribute for forecasting the accurate required spectrum, especially in other countries or in the future when a new mobile communication technologies are coming, thus one additional metric is added as a constant in order to give a room for the researchers in future to develop our proposed model and to use it for forecasting spectrum gap in future. This new metrics is denoted by “A”. Thus, the forecasted spectrum model is mathematically formulated by Eq.7.

$$\mathcal{P}_f = \frac{\mathcal{M}_f \cdot \mathcal{U}_c}{\mathcal{S}_f \cdot \eta_f} \cdot \mathcal{W}_c \cdot A \quad (7)$$

where a constant metric, A, can be replaced by other significant metrics in future. In this work, we set A to 1. The constant A generalizes our proposed model as it gives the flexibility to add or subtract the input metric based on the statistical input market available in other countries or when a new technology is coming, which are not being considered here in this work.

Then, based on the forecasted spectrum need and the CAS, the spectrum gap can be calculated. Whereas, the spectrum gap is the final output of this analysis which represents the amount of spectrum needed over the CAS. Thus, the available spectrum will be part of the total spectrum needed in future. Re-farming the current spectrum, especially the Second Generation (2G) spectrum band to Long-Term Evolution (LTE) and LTE-Advanced systems, can be part of the solution to reduce the spectrum gap in the next few years. This can be computed mathematically as the difference between the forecasted spectrum and the CAS as expressed by Eq.8.

$$\lambda_f = P_f - \omega_c \quad (8)$$

This model is used to estimate the spectrum needed and the spectrum gap for Malaysia, as illustrated in the next section. It can be also applied to estimate the spectrum needed for any other country, by only changing the input parameters in accordance to that specific country. The forecasting is performed based on the input data of various MTOs for these main five metrics. The evaluation details for these five main metrics were illustrated in the following five subsections.

### A. SITES NUMBER GROWTH

Acquiring the exact amount of sites number growth for every technology deployed during previous years must be obtained from operators, however, that is a difficult task. Therefore, another model was derived to estimate the sites number for every technology deployed by each individual operator. This model fundamentally depends on historical data for the total sites' number. This historical data is then used to estimate the sites number for the following years. The estimation begins by evaluating the annual sites growth ratios for the years that their historical data are available. The annual sites growth ratios are calculated as a ratio between the site numbers of

the current to the previous years. This can be mathematically simplified by Eq.9.

$$\zeta_y = \frac{N_y^S}{N_{y-1}^S} \quad (9)$$

where,  $\zeta_y$  denotes the site number growth for the year “y”,  $y \in [2015, 2016, \dots, 2025]$ ,  $N_y^S$  denotes the total sites number of all technologies for the year “y”, and  $N_{y-1}^S$  stand for the total sites number for the previous year “y - 1”.

Then, the Average Sites Number Growth (ASNG) ratio,  $\bar{\zeta}$ , is calculated as average across five years by the expressed formula in Eq.10.

$$\bar{\zeta} = \frac{1}{Y_n} \sum_{y=y_1}^{Y_n} \zeta_y \quad (10)$$

where,  $Y_n$  is the total number of the calculated years, which is the previous five years.

Utilizing the ASNG ratio and sites number for the previous years, the sites number for the next year is then predicted. For example, employing the ASNG ratio across the previous five years and sites number for the current year,  $N_y^S$ , the sites number for the next year,  $N_{y+1}^S$ , is then predicted. Thus, from Eq.9 and Eq.10, the forecasted sites number can be mathematically evaluated by the devised formula in Eq.11.

$$N_y^S = \bar{\zeta} N_{y-1}^S = \frac{N_{y-1}^S}{Y_n} \sum_{y=y_1}^{Y_n} \zeta_y \quad (11)$$

Following the same scenario, the sites number for the next few years can be predicted using Eq.11.

Since there are several technologies (such as 2G, Third Generation (3G) and Fourth Generation (4G)) deployed, and each technology has different site capabilities, the total sites number is distributed over the technologies. The distribution can be performed based on the number of mobile connections per technology. This can be mathematically represented by the formula in Eq.12.

$$N_y^{S_{iG}} = N_y^S x \frac{N_y^{m_{iG}}}{N_y^m} = \frac{N_y^{m_{iG}}}{N_y^m} \frac{N_{y-1}^S}{Y_n} \sum_{y=y_1}^{Y_n} \zeta_y \quad (12)$$

where,  $N_y^{S_{iG}}$  and  $N_y^{m_{iG}}$  denote the sites number and mobile connection for technology “i” at the year “y”, respectively.

Eq.12 can be applied to estimate the sites number per technology, but since each technology consists of varying network types, different sites numbers and dissimilar site's capacities, the equivalent sites number should be considered through the estimation instead of the sites number per technology. The equivalent Sites Number Growth (eSNG) is the total number of sites that have the same capacity. Calculating the eSNG can be performed based on the sites number and Equivalent Site Capacity (ESC) of each technology. This can be mathematically expressed in Eq.13.

$$N_y^{eS} = \sum_{i=1}^{N_G} e_{iG} N_y^{S_{iG}} \quad (13)$$



where,  $N_y^{eS}$  denotes the equivalent sites number at the year “y”,  $e_{iG}$  represents the equivalent site capacity for technology “i”,  $N_G$  signifies the total technologies number.

The equivalent site capacity, ESC, is a metric that represents the equal site capacity of different technologies such as 2G, 3G and 4G. It can be evaluated as a ratio between the average capacities of any technology to the latest technology. Mathematically, it can be represented by Eq.14.

$$e_{iG} = \frac{\overline{B_{iG}^S}}{\overline{B_{4G}^S}} \tag{14}$$

where,  $\overline{B_{iG}^S}$  and  $\overline{B_{4G}^S}$  denote is the average site capability for technology “iG” and the latest technology “4G”, respectively.

Since each generation has several network types (for example, 3G technology consists of UMTS, HSPA and HSPA+ networks), the site capacity of each generation depends on the network type and site specifications. Each varying network type has contrasting site capacities. Additionally, each site under the same network type may have different specifications since they can have varying capacities. Therefore, the equivalent site capacity, ESC, for each generation is firstly taken as the average value overall network types. Thus, the average site capacity,  $\overline{B_{iG}^S}$ , for technology “iG” can be mathematically expressed in Eq.15.

$$\overline{B_{iG}^S} = \frac{\sum_{j=1}^{N_n^{iG}} C_j^{iG}}{N_n^{iG}} \tag{15}$$

where,  $j$  represents the network type, e.g. network types for 3G are HSDPA, HSUPA, HSPA and HSPA+;  $N_n^{iG}$  is the total number of network types for one technology, “i”; “ $C_j^{iG}$ ” denotes the site capacity for network type “j”.

From Eq.14 and Eq.15, the equivalent site capacity, ESC, can then be calculated with Eq.16.

$$e_{iG} = \frac{\overline{B_{iG}^S}}{\overline{B_{4G}^S}} = \frac{\sum_{j=1}^{N_n^{iG}} C_j^{iG}}{N_n^{iG}} \frac{N_n^{4G}}{\sum_{j=1}^{N_n^{4G}} C_j^{4G}} \tag{16}$$

From Eq.12 to Eq.16, the equivalent sites number can be calculated as a function of sites number, mobile connection number (Collected from GSMA, which mean the GSMA method is implicitly used in our forecasting of SNG) and site capacity; as expressed in Eq.17.

$$N_y^{eS} = \sum_{i=1}^{N_G} \left( \frac{\sum_{j=1}^{N_n^{iG}} C_j^{iG}}{N_n^{iG}} \frac{N_n^{4G}}{\sum_{j=1}^{N_n^{4G}} C_j^{4G}} \frac{N_y^{m_iG}}{N_y^m} \frac{N_{y-1}^S}{Y_n} \sum_{y=y_1}^{Y_n} \zeta_y \right) \tag{17}$$

This model, in Eq.17, can be employed to calculate the equivalent sites number for any corresponding year. Utilizing this model, the sites number growth, SNG, for the forecasted year “f” can then be calculated as a ratio of the equivalent site numbers for the year “f” and the current year “c”; as

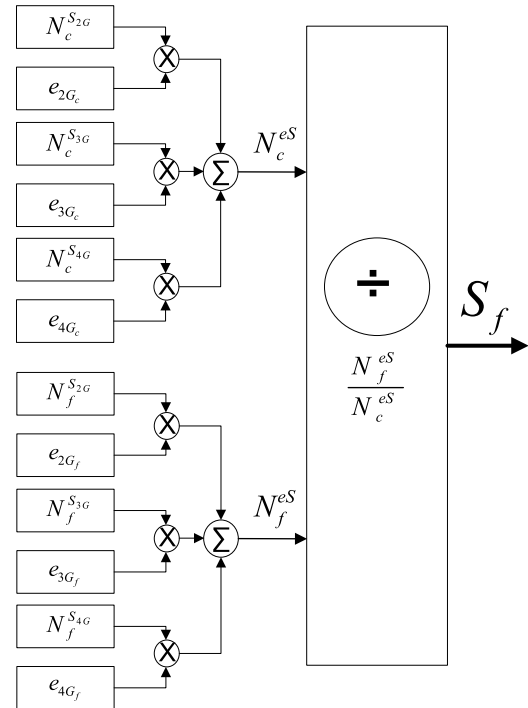

FIGURE 2. Forecasting site number growth model.

represented by Eq.18 and explained in Figure 2.

$$S_f = \frac{N_f^{eS}}{N_c^{eS}} = \frac{\left( \sum_{i=1}^{N_G} \left( \frac{\sum_{j=1}^{N_n^{iG}} C_j^{iG}}{N_n^{iG}} \frac{N_n^{4G}}{\sum_{j=1}^{N_n^{4G}} C_j^{4G}} \frac{N_y^{m_iG}}{N_y^m} \frac{N_{y-1}^S}{Y_n} \sum_{y=y_1}^{Y_n} \zeta_y \right) \right)_f}{\left( \sum_{i=1}^{N_G} \left( \frac{\sum_{j=1}^{N_n^{iG}} C_j^{iG}}{N_n^{iG}} \frac{N_n^{4G}}{\sum_{j=1}^{N_n^{4G}} C_j^{4G}} \frac{N_y^{m_iG}}{N_y^m} \frac{N_{y-1}^S}{Y_n} \sum_{y=y_1}^{Y_n} \zeta_y \right) \right)_c} \tag{18}$$

where,  $N_f^{eS}$  is the equivalent Sites Number for the forecasted year “f”;  $N_c^{eS}$  is the equivalent Sites Number for the current year “c”.

**B. MOBILE DATA TRAFFIC GROWTH**

Evaluating mobile data traffic growth for any specific year can be estimated based on a historical data for few years. The estimation can begin by evaluating the mobile data traffic growths for the years that their current and previous few years’ data are available. That can be calculated by utilizing the existing formula in Eq.19.

$$\beta_y = \frac{D_y}{D_{y-1}} \tag{19}$$

where,  $\beta_y$  denotes the mobile data traffic growth for year “y”,  $D_y$  and  $D_{y-1}$  denote the mobile data traffic for the year “y”, and the previous year “y – 1”, respectively.

Then, the average mobile data traffic growth ( $\bar{\beta}$ ) across few years,  $Y$ , can be evaluated by the expressed formula in Eq.20.

$$\bar{\beta} = \frac{\sum_{y=1}^Y \beta_y}{Y} \quad (20)$$

where,  $Y$  denotes the total years' number those are considered for taking the average value.

From the calculated average Mobile Data Traffic Growth (MDTG) ratio,  $\bar{\beta}$ , and Mobile Data Traffic (MDT) for the year  $y$ ,  $D_y$ , the mobile data traffic for the next year,  $D_{y+1}$ , can then be predicted by the simplified formula in Eq.21.

$$D_{y+1} = \bar{\beta} \times D_y \quad (21)$$

This model in Eq.21 can be used to forecast mobile data traffic for the next few years.

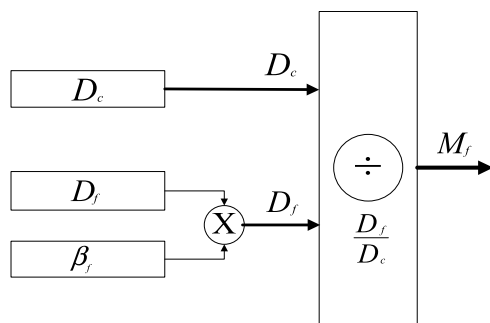

FIGURE 3. Mobile data traffic growth model.

Utilizing the available historical and the estimated (by Eq.21) mobile data traffic, the mobile data traffic growth can then be evaluated as a ratio of the forecasted mobile data traffic ( $D_f$ ), e.g. for 2020, to the current mobile data traffic ( $D_c$ ), e.g. for 2015; which was represented by Eq.22 and described by a block diagram in Figure 3.

$$M_f = \frac{D_f}{D_c} = \frac{D_{y+5}}{D_y} \quad (22)$$

### C. AVERAGE NETWORK UTILISATION

Network utilization is the ratio of the current network traffic to the maximum traffic that can be handled by the site. The actual network utilization percentage can be obtained from operators, however, that is not easy to acquire due to their policy; the information is not permitted to be shared with the public. Therefore, a new method was derived to estimate network utilization. This method mainly depends on the current network traffic and the maximum traffic for each technology.

The current network traffic can be defined as the total data that can be simultaneously downloaded by all connected subscribers to the network. Mathematically, the current network traffic can be calculated as a function of the total subscribers' number and the average equivalent download speed per subscriber. Since the total number of mobile subscribers are not all simultaneously connected to the network, the subscriber's connection probability must be considered. In consequence, a new parameter was introduced as the accessing network

probability to solve this matter. Thus, the current network traffic,  $\mathcal{R}_c$ , can be evaluated as a function of total subscriber number ( $N_{us}$ ), average equivalent download speed per subscriber overall the technologies  $B_u$  and accessing network probability ( $A_p$ ). This was presented in Eq.23.

$$\mathcal{R}_c = N_{us} B_u A_p \quad (23)$$

Regarding the maximum network traffic ( $\mathcal{R}_m$ ), it is the maximum data provided by the serving network. It can be calculated by multiplying the total number of sites by the cell's capability and the number of sectors per site. Since the actual network consists of different technologies, and each technology has various deployment sites number, sectors number and differing cell capacities, the equivalent sites number, average sectors number and equivalent cell's capacity values overall technologies were used to evaluate the maximum network traffic.

The equivalent sites number of all technologies was evaluated by the formula in Eq.17. The average sector numbers are assumed to be three overall technologies, while the equivalent cell's capacity is proportionate to the 4G cell capacity since the equivalent site number was evaluated to be equal to the 4G site. Consequently, the maximum network traffic can be simplified in Eq.24.

$$\mathcal{R}_m = N_y^{eS} \overline{N_{sr}} C_{cl}^{eq} \quad (24)$$

where,  $\overline{N_{sr}}$  denotes the average number of sectors overall technologies,  $C_{cl}^{eq}$  signifies the equivalent cell's capacity, which is corresponding to 4G cell's capacity

Since the network utilization is defined as the ratio of the current network traffic to the maximum traffic that can be handled by the site, thus, the average network utilization was mathematically represented in Eq.25.

$$u_c = \frac{\mathcal{R}_c}{\mathcal{R}_m} = \frac{N_{us} B_u A_p}{N_y^{eS} \overline{N_{sr}} C_{cl}^{eq}} \quad (25)$$

The summary of the model for evaluating the average network utilization is also illustrated in details in Figure 4.

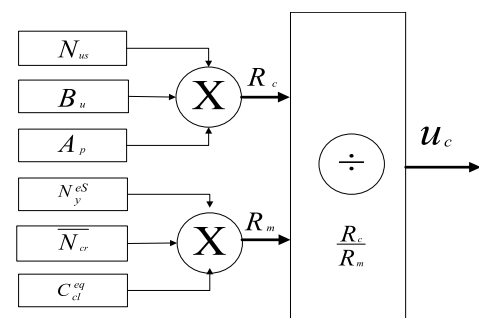

FIGURE 4. Average network utilization model.

### D. SPECTRUM EFFICIENCY GROWTH

Spectrum efficiency is usually enhanced further when a new technology is coming [66], [71], [72]. The main parameters

that determine the spectrum efficiency growth are the Modulation Scheme (MS), Sectors Number (SN) and Multiple-Input and Multiple-Output (MIMO) scheme (e.g.  $4 \times 4$ ,  $8 \times 8$ , and other higher order combinations). The settings of these parameters may vary between the sites with the same technologies, as well as, different technologies. Since it is difficult to determine the actual system settings (e.g. MS, SN and MIMO type) for each individual site from the operators, a new method was derived to estimate the spectrum efficiency growth.

The proposed method mainly depends on the average spectrum efficiency per site and the total sites' number. The evaluation begins by calculating the average spectrum efficiency per site for every technology individually. Since each technology consists of different network types (for example, the 3G network consists of HSDPA, HSUPA, HSPA and HSPA+), the average spectrum efficiency per site of any technology can be evaluated as a function of average spectrum efficiency per site and sites number of all network types. This was mathematically simplified in the formula of Eq.26.

$$\overline{\eta}_{iG} = \frac{\sum_j^{N_n^{iG}} \eta_j N_j^S}{\sum_j^{N_n^{iG}} N_j^S} \quad (26)$$

where,  $\overline{\eta}_{iG}$  denotes the average spectrum efficiency per site belonging to technology "i"; i signifies the technology type, it can be 2, 3 or 4, e.g. 2G, 3G or 4G; j stand for network type;  $N_n^{iG}$  is the total number of network types belong to technology "i";  $\eta_j$  is the average spectrum efficiency per site belonging to network "j"; and  $N_j^S$  represents the total sites number for network "j".

Since the wireless network consists of several types of technologies and each technology has a various number of sites, so the site's number per technology need to be considered for calculating the average spectrum efficiency per site. Thus, the average spectrum efficiency per site overall technologies can be represented by Eq.27:

$$\overline{\eta}_s = \frac{\sum_{i=1}^{N_G} \overline{\eta}_{iG} N_{iG}^S}{\sum_{i=1}^{N_G} N_{iG}^S} \quad (27)$$

Thus, from Eq.26 and Eq.27, the average spectrum efficiency per site overall technologies can be evaluated by Eq.28:

$$\overline{\eta}_s = \frac{1}{\sum_{i=1}^{N_G} N_{iG}^S} \sum_{i=1}^{N_G} \left( N_{iG}^S \frac{\sum_j^{N_n^{iG}} \eta_j N_j^S}{\sum_j^{N_n^{iG}} N_j^S} \right) \quad (28)$$

The formulated model at Eq.28 can be used to estimate the average spectrum efficiency per site overall technologies for any year. The differences will be only for the input data, which will be for the corresponding year. Consequently, by utilizing Eq.28, the spectrum efficiency growth,  $\zeta_f$ , can be calculated as the ratio between the spectrum efficiencies of the forecasted to the previous years; as simplified in Eq.29.

$$\zeta_f = \frac{\overline{\eta}_{sf}}{\overline{\eta}_{sc}} \quad (29)$$

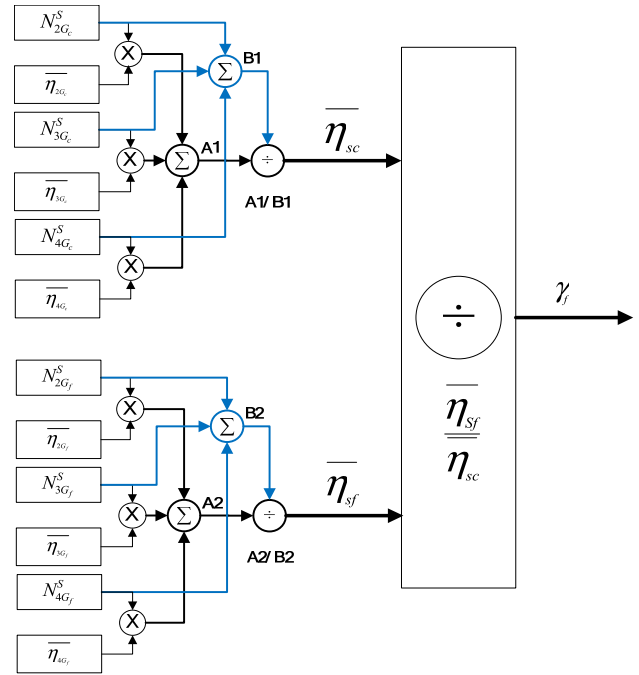

FIGURE 5. Spectrum efficiency growth model.

Both  $\overline{\eta}_{sf}$  and  $\overline{\eta}_{sc}$  can be evaluated by Eq.28, however, the input parameters should be for the corresponding year. From Eq.28 and Eq.29, the spectrum efficiency growth for the year "f" can be evaluated as a function of the average spectrum efficiency,  $\overline{\eta}_{iG}$ , and the total sites number,  $N_{iG}^S$ , per technology. Thus, the spectrum efficiency growth can finally be evaluated by the simplified mathematical model in Eq.30, which is finally simplified in details by Figure 5.

$$\zeta_f = \left( \frac{\sum_{i=1}^{N_G} N_{iG}^S \frac{\sum_j^{N_n^{iG}} \eta_j N_j^S}{\sum_j^{N_n^{iG}} N_j^S}}{\sum_{i=1}^{N_G} N_{iG}^S} \right)_f \left( \frac{\sum_{i=1}^{N_G} N_{iG}^S}{\sum_{i=1}^{N_G} N_{iG}^S \frac{\sum_j^{N_n^{iG}} \eta_j N_j^S}{\sum_j^{N_n^{iG}} N_j^S}} \right)_c \quad (30)$$

where, f is the year that need to calculate SEG for it, e.g. 2020 c is the previous year, e.g. 2015.

### E. CURRENT AVAILABLE SPECTRUM

The current available spectrum is the total frequency band allocated to every telecommunication operator by regulators, for example the MCMC in Malaysia. The current available spectrum will be part of the total spectrum needed in future. Re-farming the current spectrum, especially the 2G spectrum band, to LTE and LTE-Advanced can be part of the solution for reducing the spectrum gap in the following years. Consequently, the current available spectrum is considered as one of the main metrics used to forecast the spectrum gap in the proposed forecasting spectrum model. It will contribute

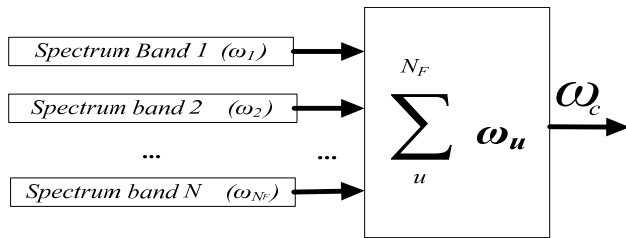

FIGURE 6. Total allocated spectrum for mobile cellular systems used.

to the forecasting of the required spectrum needed in future. The total allocated spectrum for mobile cellular systems used is the summation of all frequency bands allocated by the regulator, as illustrated in Figure 6. This was also simplified mathematically in Eq.31.

$$\omega_c = \sum_u^{N_F} \omega_u \quad (31)$$

where,  $\omega_u$  is the spectrum bandwidth of frequency band “ $u$ ”,  $N_F$  is the total number of frequency bands allocated to the corresponding for mobile cellular systems used.

#### IV. SPECTRUM GAP ANALYSIS

In this section, the proposed models those were explained in the previous section were used to analyze future spectrum gap in Malaysia. Firstly, the performance of the current mobile cellular networks was briefly explained to demonstrate the enhancements provided by 4G over 3G networks. Secondly, the sites number growth was presented to show the drastic growth in sites numbers. Thirdly, mobile data traffic growth was discussed to indicate its deep-seated advancement. Fourthly, the average network utilization was presented and discussed to show its effect on the proposed model. Fifthly, the spectrum efficiency growth is examined to illustrate the radical rise in spectrum efficiency. Sixthly, the current available spectrum bands were discussed to illustrate the licensed frequency bands that have been allocated to every telecommunication operator by the regulator in Malaysia. Lastly, the forecasted spectrum gap analysis was examined to resolve the spectrum gap that will be needed in the coming years.

##### A. MOBILE BROADBAND PERFORMANCE

This subsection highlights the current MBB performance and the actual user MBB experience in Malaysia. The presented results were analyzed based on the collected data from a measurement campaign conducted between January and February 2016, using the Samsung Galaxy S6 smartphones across five different morphologies (dense urban, urban, suburban, rural and indoor) in Klang Valley, Selangor, Johor, Sabah and Sarawak. The measurements covered two MBB services, web browsing of three distinctive webpages (i.e. Google, Instagram and Mstar webpages) and video streaming of 720p low and 1080p high resolution videos. Our MBB research

TABLE 3. Measured key performance indicators (KPIs).

Software Testing Application	Measured Key Performance Indicators (KPIs)
MBB Explorer (WEB)	1. Average Page Download Speed (APDS).
	2. Average Page Response Latency (APRL).
	3. Average Page Display Latency (APDL).
	4. Average of Ping RTT (APRTT).
Speedvideo (VIDEO)	1. Average Mobile vMOS Score.
	2. Average Video Total Download Rate (AVTDR)
	3. Average Initial Buffering Latency (AIBL).
	4. Average of Average Video E2E RTT Ping Delay (AVRTT).

For video services, the mobile video mean opinion score (vMOS) indicator, taking account factors such as the video content quality, the stalling time and buffering time when streaming a video, provides a comprehensive performance score on a scale of 1 to 5 (Higher vMOS number represents better network performance and level of user experience). Further details about these KPI can be found in our white paper [73].

gathered performance data KPIs (Table 3) on three Malaysian Mobile Network Operators (MNOs): Maxis, Celcom and Digi. This test measured four metrics: coverage, latency, satisfaction and speed.

This research was designed to gather data that would enable the assessment of the real performance of MBB delivered to consumer smartphones over the three Malaysian MNO networks by simulating real scenarios where mobile users cannot lock their smartphones to any technology. As a result of this designed research set-up, the MBB data compiled for one test area contains data of 2G, 3G and 4G technologies. Since the collected measured data for 2G technology is meagre and not all 2G networks can provide mobile data, the discussion only focused on the performance of 3G and 4G networks. Thus, a comparison between the performance of 3G and 4G networks was analyzed and discussed using selected parameters; as listed in Table 3. The main aim of this comparison is to portray the enhancements provided by the 4G network over the 3G network; moreover, to show the percentage of mobile connection to every network (2G, 3G and 4G networks).

Figure 7 displayed the performance of 3G and 4G networks measured by the MBB Explorer (WEB) and Speed-Video (VIDEO). The results indicated that 4G networks perform much better than 3G networks; 4G technology has superior MBB performances than 3G technology overall KPIs. These differences were consistent across all mobile operators and are unsurprising, as we would expect consumers to experience a noticeable improvement in using a mobile broadband service over a 4G network compared to a 3G network. For instance, the average 4G download speed for videos is 1856.5 kbps, and for the web its 5141.9 kbps; which is better than the 3G average download speed of 1483.7 kbps for videos and 1986.7 kbps for the web. On average, across all KPIs, morphologies and MNOs, the results indicated that the 4G network significantly outperformed 3G networks. In addition, the Average Initial Buffering Latency of the 4G network is much less (by around 80%) than the 3G network.

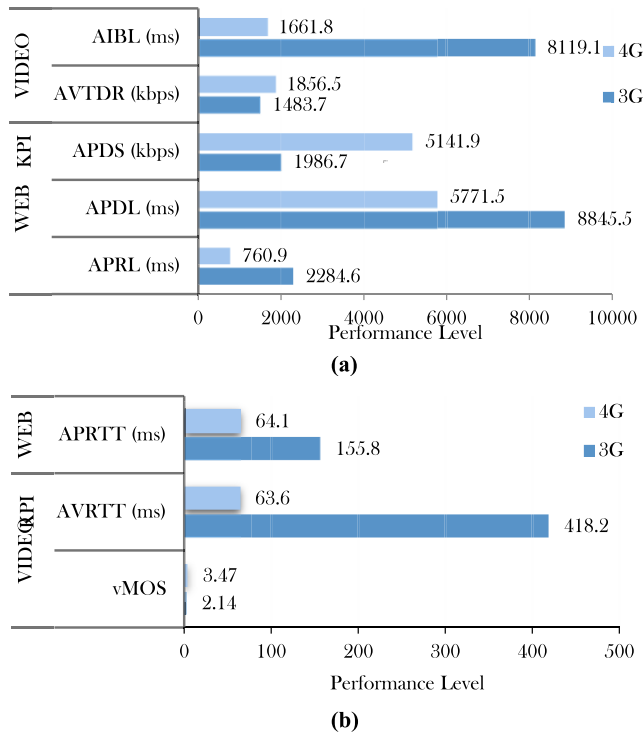

**FIGURE 7.** The average WEB and Video measured KPIs for 4G and 3G technologies. (a) The AIBL, AVTDR, APDS, APDL and APRL. (b) The average APRTT, AVRRTT and vMOS.

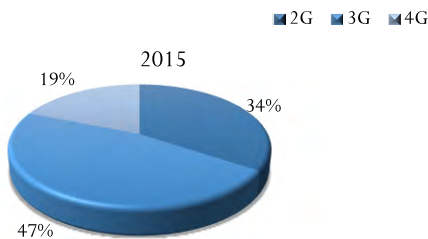

**FIGURE 8.** Mobile Connection for 2G, 3G and 4G networks.

Even with these enhancements provided by the 4G network, the 3G network is still the dominant network compared to both 2G and 4G networks. Figure 8 presented the percentage of mobile connection for 2G, 3G and 4G networks. The results represented the average mobile connection overall morphologies and operators in Malaysia. They further indicated that the mobile connection to 3G networks is much more than the connection to 2G and 4G networks. On average, overall morphologies and operators, the 3G network remains dominant in Malaysia. Consequently, most mobile handset subscribers do not have the 4G service, especially at the main road between states, suburban areas located so far from big cities and rural morphologies. One of the main reason for this would be the unavailability of 4G coverage. Once the coverage issue is resolved, the 4G will change everything.

The 4G network provides much more enhancements compared to the 3G network overall KPIs, however, the 4G coverage is still restricted in a few places. Thus, extending the

deployment of the 4G network can contribute to addressing the enormous increase of mobile data demands in the following years. This can be conducted by upgrading 2G and 3G networks to 4G and 4G+ networks. Although the 4G network can contribute to fulfilling mobile data demands, the rapid and tremendous surge in such demands may not be completely met by 4G and 4G+ networks. Additional spectrum may still be needed in 2020, even with the extension of 4G coverage.

### B. SITES NUMBER GROWTH

Sites Number Growth (SNG) contributes to fulfilling mobile data demands, however, the increase of SNG leads to the increase on system capacity, providing higher throughput. As a result, operators must keep annually renewing, installing and upgrading their sites in order to meet the rapid data demand growth and the emerging of new technologies. This indicates that mobile data traffic has an inverse relationship with SNG. Since the increase of mobile data traffic leads to the increase of the spectrum gap, the SNG will have an inverse relationship with the spectrum gap as well. In other words, when the number of sites increase, the total spectrum gap will decrease. Therefore, SNG is considered to be a significant metric used to estimate the spectrum gap in future. Thus, sites number growth was presented and discussed in this subsection for the years 2015 to 2020.

The presented results in this subsection were predicted based on historical sites numbers data collected from the MCMC [74] annual reports for years 2007 to 2014. Based on the available data, the annual sites growth ratios for years 2008 to 2014 (excluding 2010 and 2011 due to unavailability of data) were calculated utilizing Eq.9. Next, the Average Sites Number Growth (ASNG) ratios across the five years (2008, 2009, 2012, 2013 and 2014) were computed using Eq.10. Then, the ASNG ratios across the previous five years and sites number for the years 2014 are used to estimate sites number for 2015 using Eq.11. Following the same scenario, the sites numbers for the years 2016 to 2020 were predicted. The predicted sites numbers were then distributed over four main operators (Maxis, Celcom, Digi and U-Mobile) based on their capacities ratios. That was mathematically evaluated by the expressed formula in Eq.32.

$$N_y^{SO} = N_y^S C_y^O \tag{32}$$

where,  $N_y^{SO}$  is the total sites number for operator “o” at the year “y”,  $C_y^O$  denotes the capacity ratio of operator “o” at the year “y”.

The operator capacity ratio can be evaluated as a percentage of the operator’s mobile connection numbers to the entire mobile connection numbers of the country. That represented mathematically by Eq.33.

$$C_y^O = \frac{N_y^{MO}}{N_y^{MT}} \tag{33}$$

where,  $N_y^{MO}$  signifies the numbers of mobile connection for operator “o” at the year “y”,  $N_y^{MT}$  denotes the total numbers of mobile connection overall the country.

Accordingly, from Eq.11, Eq.32 and Eq.33, the sites number for any operator,  $N_y^{SO}$ , at year “y” was estimated by applying the mathematical formula in Eq.34.

$$N_y^{SO} = \frac{N_y^{MO}}{N_y^{MT}} \frac{N_{y-1}^S}{Y_n} \sum_{y=y_1}^{Y_n} \zeta_y \quad (34)$$

Utilizing this model, in Eq.34, and based on the input data collected from MCMC [74], and GSMA [52], the sites number growths were estimated for each operator individually. Then, sites number growth was used with the sites capacities and the number of mobile connections, utilizing Eq.11, to estimate the ESN. The estimated sites number growth is presented in Figure 9, while the estimated ESN is presented in Figure 10.

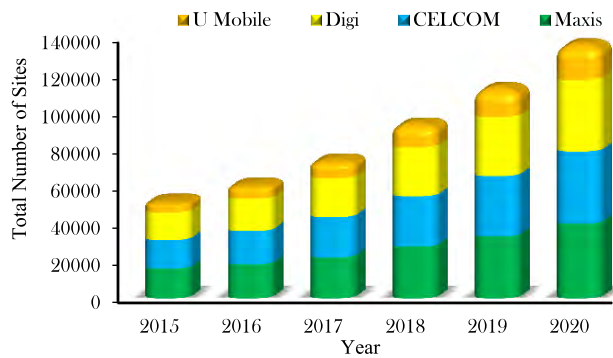

FIGURE 9. SNG for various operators in Malaysia.

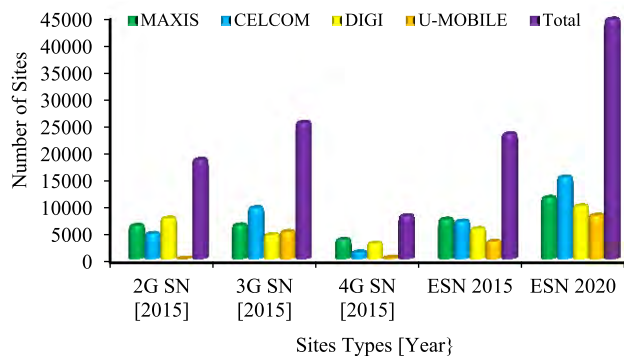

FIGURE 10. Site numbers and ESNs in Malaysia.

Figure 9 illustrated the dramatic sites number growth from 2015 to 2020 for four main operators in Malaysia. The results indicated that the sites number growth will continue to increase in the next few years. The predictable Average sites number growth ratio in 2020 will reach up to 264% as compared to 2015. These predicted results are close to what was forecasted by HUAWEI in [75]. That provides more evidence about the efficiency of our proposed model for forecasting the site number growth. The results in Figure 10

present the sites’ number of three various technologies and the ESN based on four main operators in Malaysia. The presented sites’ numbers are for the year 2015, while the ESNs are for the year 2015 and 2020. The results confirmed what was presented in Figure 8, in which means the 3G network is still the dominant network as compared to both 2G and 4G networks. The results indicated also that the ESN will continue to increase in the next few years. Whereas, the predictable total ESNs of all operators in 2020 will reach up to 191.8% as compared to 2015. These increase in SNG and ESN contribute to the reduction of the spectrum gap in 2020 due to the inverse relationship between SNG and the spectrum gap. Nevertheless, there is still a deficiency in the spectrum gap which requires fulfilment for 2020.

### C. MOBILE DATA TRAFFIC GROWTH

As illustrated in subsection A, when a new technology arrives, the main improvement is normally in the quantity of provided data to users. This is because mobile data traffic is constantly and radically increasing, therefore, telecommunication system developers must continuously improve the system data rate in order to fulfil mobile data demand growth. Therefore, new technologies lead to the increment in data demands. Consequently, this subsection presents and discusses the MDTG and the effect of this growth on the spectrum gap.

TABLE 4. Mobile data traffic and growth ratio in Malaysia.

Variable	Units	2012	2013	2014	2015	2016	2017	2018	2019	2020
MDT ( $M_y$ )	PetaBytes	62	125	194	296	430	630	967	1491	2364
$\beta$	Ratio	-	2.03	1.55	1.52	1.45	1.47	1.53	1.54	1.59
$\bar{\beta}$	Ratio	-	-	-	-	-	-	-	1.59	-

\*MDT is the mobile data traffic

The MDT for Malaysia was collected from the Analysys Mason report for the years 2012 to 2019 [51], as presented in Table 4. This data was used to estimate the mobile data traffic for the next few years, and to further calculate the mobile data traffic growth. The estimation begins by evaluating the annual MDTG ratios, as presented in Table 4, utilizing Eq.19. Consequently, the Average Mobile Data Traffic Growth ( $MDTG$ ) across the years of 2012 to 2019 were evaluated using Eq.20. From the calculated  $MDTG$  and MDT for the year 2019, the MDT for the year 2020 was then predicted by employing Eq.21. These data represents the total data overall Malaysia. Thus, these data traffic were distributed over the top four main operators (Maxis, Celcom, Digi and U-Mobile) in Malaysia by applying Eq.35.

$$D_y^o = D_y C_y^o \quad (35)$$

where,  $D_y^o$  denotes the mobile data traffic for operator “o” in the year “y”; while  $C_y^o$  is the operator capacity, which can be evaluated by utilizing Eq.33.

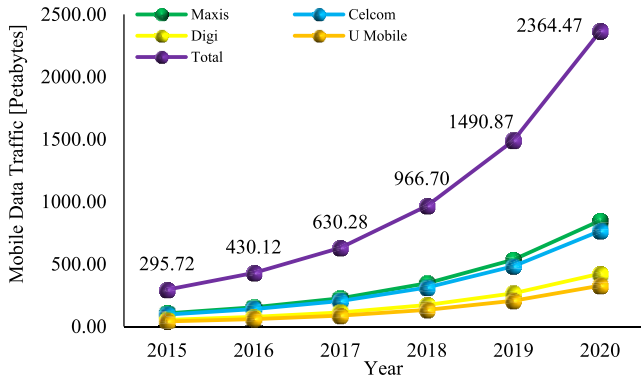

FIGURE 11. MDTG for different operators in Malaysia.

Based on these forecasted data, the mobile data traffic growth for Malaysia between the years 2015 and 2020 were presented in Figure 11. The presented results are for the whole country and the four main operators in Malaysia individually. The results showed that the total MDT for Malaysia is dramatically high, reaching up to 2364.47 Petabytes for 2020. That means the total MDT is expected to increase around eight-times more than the year 2015. Moreover, this tremendous surge in data demand (eight-times) will be required for every operator as well. This fast growth can be attributed to several factors; as illustrated in Section II.

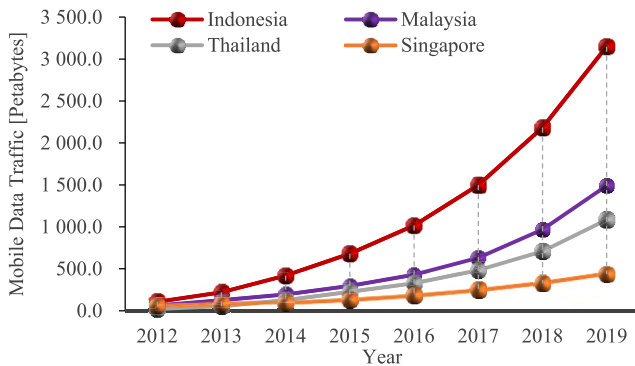

FIGURE 12. MDTG for Malaysia and selected countries.

The predicted MDTG of Malaysia is also compared to the MDTG of Indonesia, Thailand and Singapore; as predicted by Analysys Mason [51] and presented in Figure 12. From these predicted results, the average annual MDTG for Malaysia will be 159% per year, while for Indonesia, Thailand and Singapore it will be around 164%, 183% and 132%, respectively. These results demonstrate that the growth rates extensively vary from country to country, where Indonesia has the highest MDTG rate, followed by Malaysia, then Thailand and Singapore. In general, the significant escalation in mobile data traffic will lead to the increase of the spectrum gap for 2020. The effect of the MDTG increment on the spectrum gap was illustrated in Figure 13. These results were predicted when all the other metrics (SNG, ANU, SEG and CAS) were fixed, except for the MDTG metric. The results showed that

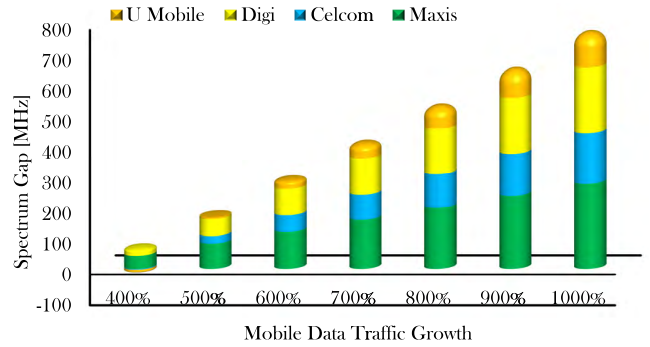

FIGURE 13. Spectrum gap versus mobile data traffic growth.

the increase in MDTG directly increases the spectrum gap, which means if the MDTG is increased further, the spectrum need will also increase as well. Therefore, the MDTG is considered as one of the most significant metrics used in the developed FSG model to estimate the spectrum gap in the coming future.

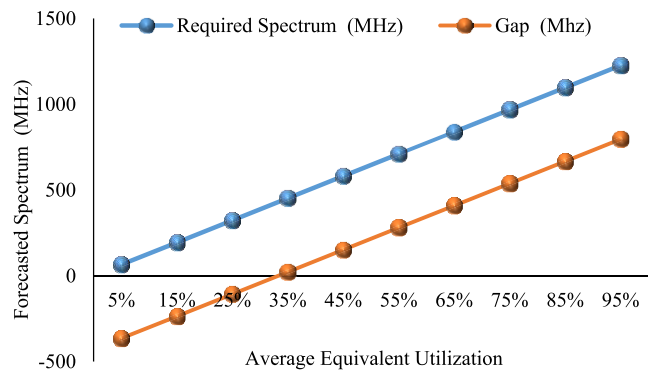

FIGURE 14. Effect of ANU on the proposed SM ( MDTG = 300%; SEG = 100%; SNG = 100% , CAS = 430 MHz , A = 1).

D. AVERAGE NETWORK UTILISATION

Average Network Utilisation also one of the significant input metrics used for forecasting the future required spectrum in the proposed model. Figure 14 shows the relation between the forecasted spectrum and spectrum gap with the ANU. From the presented results it has been absorbed that the relationship between the forecasted spectrum and spectrum gap with ANU is a linear relationship. For example, when the ANU around 55% the forecasted required spectrum and spectrum gap will be 710 MHz and 280 MHz, respectively; while when the ANU increases up to 95% the forecasted required spectrum and spectrum gap will be increased to around 1097 MHz and 796 MHz, respectively. These results show the significant effect of ANU on the forecasted spectrum and spectrum gap in future.

E. SPECTRUM EFFICIENCY GROWTH

In addition to the enhancements provided by increasing the sites number, the spectrum efficiency growth is also

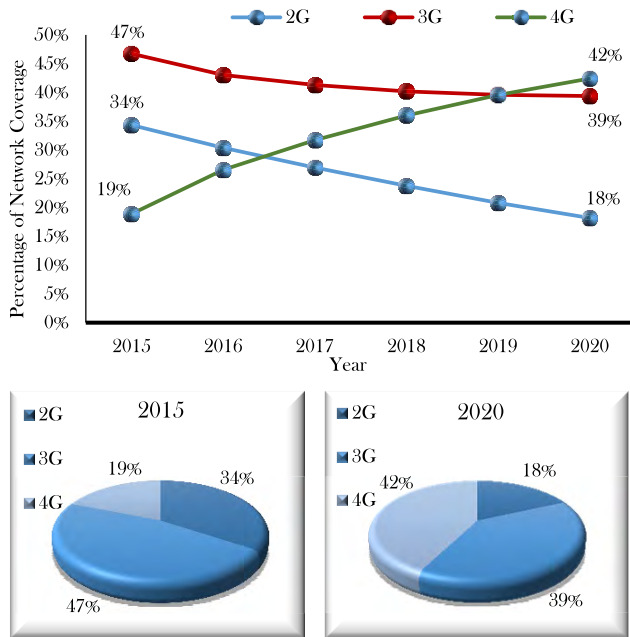

FIGURE 15. Network coverage of diverse technologies types in Malaysia.

considered as a crucial metric that can fulfil future data demands. SEG can contribute to reducing the forthcoming spectrum needs. This can be performed by upgrading the current networks (2G and 3G) to new technologies such as the 4G (LTE and LTE-Advanced systems). Based on several predicted studies [51], [52], all operators in Malaysia will keep upgrading 2G and 3G sites to LTE and LTE-Advanced sites; moreover, they will continuously install new LTE and LTE-Advanced sites to fulfil the future surge in data demands. These upgrades and new installations will offer more data and higher spectrum efficiency, which will contribute to reducing the spectrum need in 2020. Figure 15 displayed the predicted network coverage for all technology types; such as the 2G, 3G and 4G+. The coverage percentages are estimated based on the mobile connection number reported by GSMA for every individual technology in Malaysia. From the results in Figure 15, in 2015, the 3G was still the dominant network, while the 4G was the less deployed network. However, in 2020, the predicted coverage provided by the 4G will increase, while the 2G and 3G networks will decrease. The 4G deployment in 2020 will reach up to 42% of the total deployed networks, while the 2G and 3G will reduce to 18% and 39%, respectively. This signifies that the deployment of 4G networks in 2020 will be extended to 224% compared to 2015, while the 2G and 3G will reduce to 52% and 84%, respectively, as compared to 2015. This increase in the predicted coverage provided by 4G and 4G+ will offer additional data and higher spectrum efficiency, which will reduce the spectrum need as well.

These upgrades and new installations of the 4G network coverage in 2020 will contribute to enhancing system performance in general, especially spectrum efficiency; as illustrated in Figure 16. This enhancement is normally due

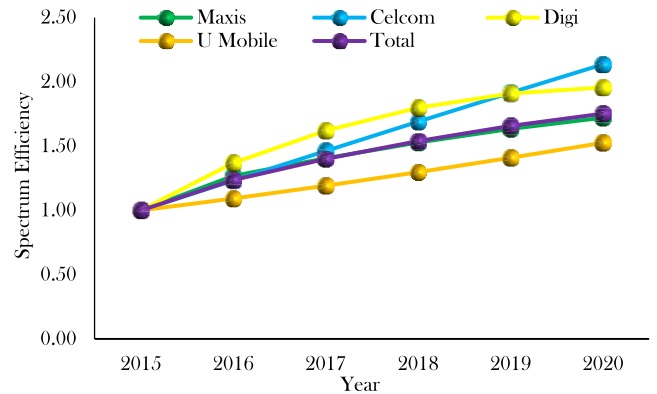

FIGURE 16. Spectrum efficiency for different MNOs types in Malaysia.

to the increase of sector numbers, implementing massive MIMO and higher modulation schemes; such as 64-QAM and 254-QAM. The results portrayed that the extension of the 4G network coverage in 2020 will contribute to the enhancement of spectrum efficiency by up to 167% on average overall operators. Therefore, upgrading 4G networks to 42% and reducing 2G and 3G coverage to 18% and 39%, respectively, will enhance spectrum efficiency 1.67 times more compared to 2015. This enhancement in spectrum efficiency will contribute to meeting future data demands, which will lead to the reduction of the spectrum gap as well.

TABLE 5. Allocated spectrum band for every operator in Malaysia [76].

Operator	$\omega_1$ 850 MHz	$\omega_2$ 900 MHz	$\omega_3$ 1800 MHz	$\omega_4$ 2100 MHz	$\omega_5$ 2300 MHz	$\omega_6$ 2600 MHz	$w_c$ MHz
Maxis	.	2 x 10	2 x 20	2 x 15 5	.	2 x 10	115
Celcom	.	2 x 10	2 x 20	2 x 15 5	.	2 x 10	115
Digi	.	2 x 5	2 x 20	2 x 15 5	.	2 x 10	105
U-Mobile	.	2 x 5	2 x 15	2 x 15 5	.	2 x 10	95

<sup>a</sup>The total spectrum allocated to all MNOs in Malaysia is 650 MHz.

F. CURRENT AVAILABLE SPECTRUM

The current available spectrum is the licensed frequency band that has been allocated to every telecommunication operator by the regulator, which is known as MCMC in Malaysia. The MCMC is the Malaysian agency that regulates, manages and monitors the use of frequency spectrum in communication and multimedia industries [76]. Table 5 illustrated the allocated spectrum by MCMC for four main telecommunication operators in Malaysia: Maxis, Celcom, Digi and U-mobile [76]. The huge growth in mobile services and applications has led to the dramatic increase of spectrum needs. These accessible spectrums are continuously extended



**TABLE 6.** Data of the five main input parameters used for forecasting the required spectrum in Malaysia.

Operator	2G Sites in 2015	3G Sites in 2015	4G Sites in 2015	Equivalent Site in 2015	Equivalent Site in 2020	Total Traffic (PB) in 2015	Total Traffic (PB) in 2020	Current Spectrum (MHz) in 2015	Average Equivalent Utilization in 2015	Traffic Growth (2015-2020)	Spectrum Efficiency Growth (2015-2020)	Site Number Growth (2015-2020)	Required Spectrum (MHz) in 2020
Maxis	6156	6265	3565	7324	11340	91.66	732.86	115	85%	800%	160%	155%	316
Celcom	4688	9452	1287	6958	15124	88.45	707.23	115	85%	800%	160%	217%	225
Digi	7530	4470	2897	5579	9789	85.41	682.92	105	85%	800%	160%	175%	253
U Mobile	0	5042	225	3250	8068	30.20	241.46	95	85%	800%	160%	248%	163
<b>Total</b>	<b>18374</b>	<b>25230</b>	<b>7974</b>	<b>23112</b>	<b>44320</b>	<b>295.72</b>	<b>2364.47</b>	<b>430</b>	<b>85%</b>	<b>800%</b>	<b>160%</b>	<b>192%</b>	<b>957</b>

in order to meet the rapid increase of various mobile services; such as the internet, video streaming and the excessive amounts of various application services. The massive surge in mobile services has led to the dramatic increase of spectrum needs. Consequently, the increase of the currently available spectrum is essentially reflecting the sizable increase of mobile services and applications. Thus, these total spectrum bands illustrated in Table 5 were used as input data for forecasting the required spectrum for Malaysia’s future.

**G. FORECASTED SPECTRUM**

Forecasted Spectrum (FS) is known as the total spectrum required in future which can be forecasted based on different market data. This section presented the forecasted spectrum needed by Malaysia in 2020. The forecast was performed based on a new developed spectrum forecasting model, which depends on five main metrics; as illustrated in subsection (III). These five metrics have a direct and inverse relationship with the forecasted spectrum; as briefly summarized in Table 2. Based on these metrics, the required spectrum for Malaysia was forecasted utilizing Eq.7, and the spectrum gap was calculated using Eq.8. The forecast was performed for four main operators in Malaysia (Maxis, Celcom, Digi and U-Mobile), which account for approximately 95% of the Malaysian mobile market share GSMA [52]. The current and historical market data used to perform the spectrum gap analysis are collected from sources such as MCMC, OpenSignal, Analysys Mason, GSMA and HUAWEI. For example, the input historical site numbers data, from the year 2007 until 2014, for various operators in Malaysia has been collected from the MCMC annual report 2015 [74]. The number of users and mobile connections for each operator, from 2015 until 2020, have been collected from GSMA [52]. Each operator has a different number of users (MAXIS has thirteen million users, CELCOM has eleven million users, while DIGI has seven million users in 2015). Regarding the mobile network traffic, it has been collected from Analysys Mason forecasting report [51].The main data of the five input parameters that were used in forecasting the required spectrum are illustrated in Table 6.

That data is for the four main operators in Malaysia. The prediction was executed for every individual operator, and the total forecasted spectrum was combined to present the entire spectrum needed for Malaysia, as illustrated in Table 6. In 2017, the total current available spectrum allocated to all MNOs in Malaysia is 650 MHz. Based on this current value and when utilizing the developed model, the required spectrum for MBB in Malaysia by 2020 was forecasted.

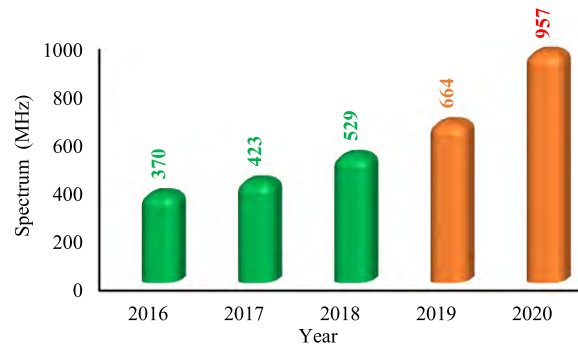

**FIGURE 17.** The forecasted spectrum for MBB in Malaysia.

Figure 17 shows the forecasted spectrum needed by the proposed model for the years 2016 and 2020. These results are presented to prove the validity of the proposed model. From the presented results it can be absorbed that, the forecasted required spectrum by our model for the years 2016, 2017 and 2018 are still less than what was allocated by MCMC [76]. Whereas, the actual allocated spectrum by MCMC in Malaysia for the years 2016, 2017 and 2018 is 650 MHz. This allocated spectrum is still sufficient at the instant, even though part of it still has not be used. Since the forecasted spectrum for these three years is less than what was allocated by MCMC, the proposed model seems to be more accurate and that gives an indication of the validity of our model. Moreover, the forecasted spectrum results were submitted to the spectrum division of Malaysia regulator, MCMC (<http://www.mcmc.gov.my>), and they have verified the forecasted results and compared the results with what

actually Malaysia need in 2020 based on their experience and prediction. Then, they have approved the forecasted results. Based on that, WCC with MCMC together published that results in a white paper [73].

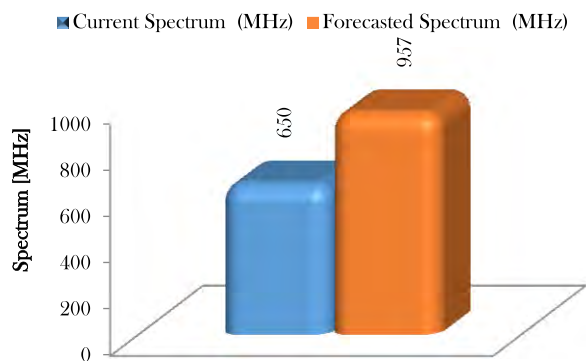

FIGURE 18. The current and forecasted spectrum for MBB in Malaysia.

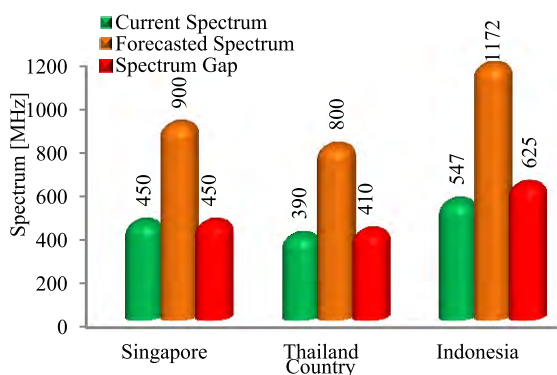

FIGURE 19. Current and forecasted spectrum for three neighboring countries to Malaysia.

Figure 18 and Figure 19 displayed the current available spectrum, the required spectrum and the Spectrum Gap needed in 2020 for Malaysia and for other three selected neighbouring countries, respectively. The presented results for Malaysia is based on our developed model, while the results presented for the three neighbouring countries: Singapore [75] Thailand [75] Indonesia [75] were predicted by utilizing Pyramid Research model [61]. The results indicated that the required spectrum needed for Malaysia in 2020 will reach up to 957 MHz. Since the total available spectrum allocated in Malaysia is currently 650 MHz, the spectrum gap in 2020 will be 307 MHz. Consequently, by 2020, Malaysia will need around 307 MHz of additional spectrum to fulfil the high increase of data demands. This predicted result for Malaysia seems to be close to that was predicted for Singapore with little bit difference.

For future spectrum needs forecasting problem, one of the open problem is that we are unable to define any cost function, e.g. Mean Square Error (MSE), to evaluate the forecast error. This is because there are no true spectrum needs data available for past, current and future years. The only available data is the amount of spectrum allocated in

the country, e.g. The Malaysia regulatory agency MCMC allocated 650MHz spectrum for mobile broadband in 2016. Figure 17 shows the forecasted spectrum needs by our proposed model in Malaysia for 2016-2020. We can see that if the allocated spectrum of 650 MHz remain the same till 2020, our model forecasted that the spectrum needs are sufficient only until 2018, while more spectrum should be allocated by 2019 onward.

V. RECOMMENDATIONS AND SOLUTIONS

The much needed spectrum gap is becoming a serious issue which requires consideration by both regulators (MCMC) and operators in order to establish the best solution that can fulfil the data demands of future. Meeting these data requirements can be achieved through several methods. A few solutions that can significantly help solve this issue include:

- A. Finding a potential spectrum band
- B. Off-loading mobile data traffic to unlicensed bands
- C. Increasing sites number growth
- D. Enhancing spectral efficiency growth

The last three solutions can solve data demands without the need for any additional spectrum bands. The details of the potential spectrum band and the effect of the last three solutions were illustrated in the following subsections.

A. POTENTIAL SPECTRUM BANDS PROPOSAL TO BE RELEASED IN MALAYSIA

From 2015 to 2018, Malaysia had 630 MHz of spectrum allotted to mobile services [74], [76]. However, as discussed in subsection G under section IV, roughly 307 MHz of additional spectrum is needed for the year 2020. The expectation is even more when the Internet-of-Things (IoT), Machine-to-Machine (M2M) communication and all 5G’s applications arrive. To support the explosive traffic increase and higher performance expectations in Malaysia, two potential bands can be employed. The candidate frequency bands available for identifying the spectrum for future development of IMT and IMT-Advanced systems were illustrated in the proposed timeline in Figure 20. These two spectrum bands include 700 MHz and 1.4 GHz; which are highly anticipated under WRC-15.

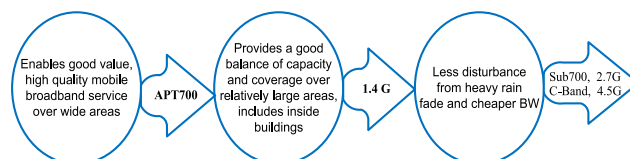

FIGURE 20. Potential bands target to be released in Malaysia.

1) 700 MHz

This band is an important swathe of spectrum due to its excellent propagation characteristic, allowing its signals to easily penetrate buildings and walls. The 700 MHz signals are widely used to cover larger geographical areas (relative to higher frequency bands) for broadcasting services.

The switch-over to digital television provides terrestrial broadcasters with significantly more capacity for additional channels or high definition television. For FDD arrangements, the spectrum should be allocated as in the following:

- A lower guard band of 5 MHz should be allocated from 698 MHz.
- An upper guard band of 3 MHz should be allocated from 803 MHz.

From Figure 21 (a), an amount of 90 MHz ( $2 \times 45$  MHz) spectrum can be provided from the 700 MHz band to IMT. Four blocks paired with the combination size of 10 MHz and 15 MHz are suggested and will be conducted by operators. An arrangement could be proposed, as illustrated in Figure 21(b):

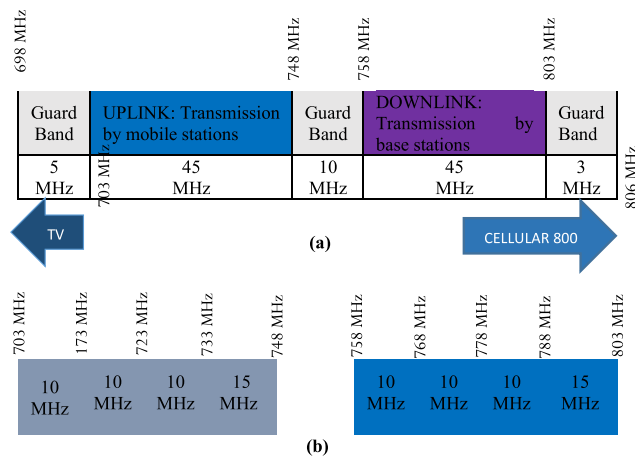

FIGURE 21. Proposed 700 MHz spectrum allocation of Region 3.

Spectrum in the 700 MHz band became available, likely around 2018, when broadcasters in Malaysia stop transmitting analogue signals over the spectrum and move to the lower band of 470 MHz and 694 MHz. MYTV Broadcasting or MYTV, owned by Altel Communications, is the first to broadcast free digital terrestrial television, and they had already launched their services in August 2016. Numerous benefits can be attained from using this 700 MHz band for IMT; for instance, the coverage radius is expected to be at least two times that of 1800 MHz and equivalent to 12 times the coverage area. It ultimately facilitates the emerging mobile broadband in new markets, rural areas and within buildings.

2) 1.4 GHz (L-BAND)

The characteristic of the L-band could provide a good combination of mobile coverage and capacity. It functions below the 1GHz band, which may be insufficient to address wider capacity needs. The frequency bands of 1427-1518 MHz is previously used for marketable IMT services in Japan [77]. In other countries, the frequency range is mainly employed for fixed links and radar, programs, special media events and aeronautical telemetry services. Figure 22 showed the



FIGURE 22. L-Band frequency allocation in Malaysia.

frequency allocation for the L-band in Malaysia, currently only occupying the spectrum of 1452-1492 MHz.

Various regional and international countries have started to re-farm the L-band (1427–1518 MHz) to cater to MBB services. Currently, there are two main band plan proposals on how to use the L-band for MBB: FDD band plan proposed by Japan and unpaired band plan to support SDL (Supplementary Downlink) mode proposed by European countries. In Europe, the Electronic Communication Committee (ECC) has harmonized part of the L-band (1452-1492 MHz), as illustrated in Figure 23, to allow individual countries to adopt this spectrum for SDL. 3GPP is yet to decide on the band plans for the L-band.

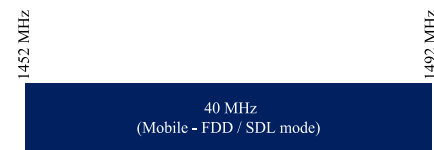

FIGURE 23. Proposed 1400 MHz spectrum allocation.

After acquiring and considering the spectrum from bands 700-MHz and 1.4 GHz, a total of 130 MHz additional spectrum is recommended for MBB services; as summarized in Table 7 and Figure 24.

TABLE 7. Summary of the spectrum allocation from band 700 MHz and 1.4 GHz.

Spectrum Band	Amount of Spectrum	Release Year (Estimated)	Spectrum to Allocate	Total New Spectrum	Remaining Spectrum Gap
700 MHz (703-748/758-803)	90 MHz	2017	307 MHz	130 MHz	197 MHz
1400 MHz (1452-1492)	40 MHz	2019	307 MHz	130 MHz	197 MHz

B. OFF-LOADING MOBILE DATA TRAFFIC

Fulfilling future mobile data demands is not only solved by finding a new spectrum band, but can be further addressed with other solutions. One solution would be off-loading mobile data traffic onto unlicensed bands. Off-loading means transferring some of the cellular network data traffic to the network that is working on unlicensed bands.

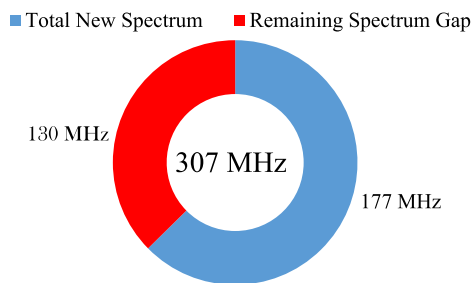

FIGURE 24. Total new spectrum and remaining spectrum gap.

For example, mobile data traffic of licensed cellular networks (2G, 3G and 4G) can be delivered over unlicensed networks such as Wi-Fi and Femtocell. This off-loading solution will solve data traffic growth. Furthermore, it will provide additional advantages such as providing better coverage, faster connections, increased capacity, save battery since the user is close to the Access Point (AP) and have reliable connection (better connectivity).

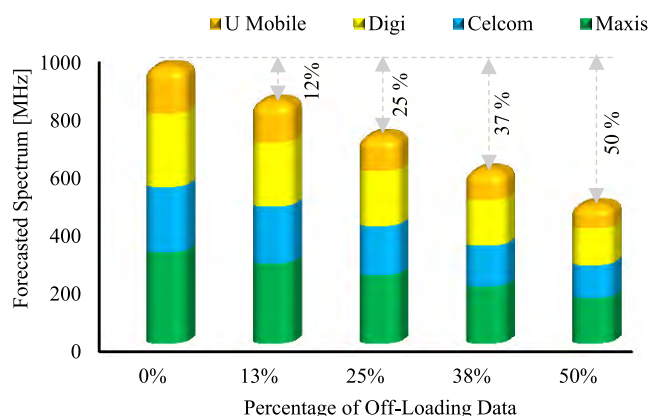

FIGURE 25. Effect of offloading mobile data traffic onto unlicensed band for reducing the required licensed spectrum.

Figure 25 displayed the effect of off-loading mobile data traffic to unlicensed spectrum bands. The results demonstrated the relationship between the spectrum gap in 2020 and the increase of off-loading mobile data to unlicensed bands. It can be noted that when the off-loading ratio increases, the spectrum gap decreases. For example, if 13 % of the predicted mobile data in 2020 is off-loaded onto Wi-Fi or femtocell networks, the spectrum gap will reduce by 12%. Similarly, off-loading 50% of mobile data traffic onto Wi-Fi and femtocell networks will reduce mobile data traffic of cellular networks from 2364.47 Petabytes to 745.44 Petabytes. That will lower the spectrum gap in 2020 by 50%, as compared to the year 2015.

As a result, off-loading mobile data traffic onto unlicensed bands will significantly diminish the spectrum gap for the coming years. Accordingly, if operators off-load 50% of mobile data traffic onto unlicensed bands, the spectrum gap will reduce to 479MHz corresponding to 50% gain saved as compared to 957MHz with 0.0% off-loading.

Thus, off-loading mobile data traffic onto unlicensed bands can be considered as a relevant strategy to solve the future spectrum gap.

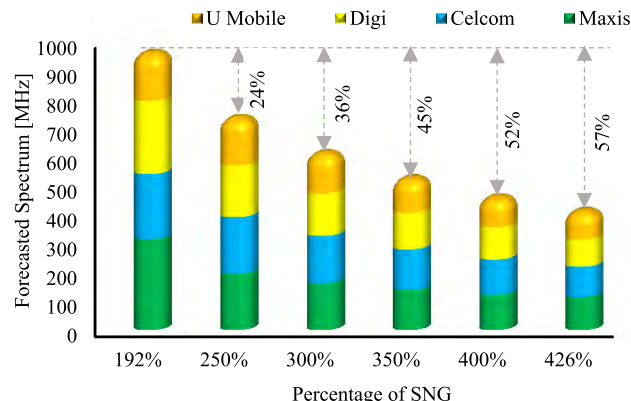

FIGURE 26. Effect of sites number growth for reducing the required licensed spectrum.

C. EFFECT OF SITES NUMBER GROWTH

Similar to the off-loading solution, the growth of sites numbers will also contribute to addressing mobile data traffic and reducing the spectrum gap in future. In Figure 18, the predicted spectrum gap for Malaysia was estimated based on the average of 200% of sites number growth; as illustrated in subsection G under section IV. However, if the sites number growth increases, then the offered mobile data traffic will definitely increase, leading to decreasing licensed spectrum gap. Figure 26 illustrated the effect of sites number growth on the licensed spectrum gap. The results indicated that when the site number growth is increased, the spectrum gap will decrease. For instance, by increasing the sites number growth to 426%, the licensed spectrum gap will scale down to 409 MHz. This is a highly significant result, which reduced the needing of a future spectrum to 57 % in 2020.

One of the main challenges that faces this solution is the cost of implementing new base stations. For example, extending the deployment of sites to N-times more with the exact spectrum quantity and similar kind of Radio Access Technology (RAT) will demand N-times more network costs. There are also other challenges that face this solution; in several countries, MNOs face limited or too much rule on infrastructure deployment. This rule limits mobile operators' ability to install new sites and that leads to an increase in infrastructure sharing. Nonetheless, the Sites Number Growth can be considered as one solution which can curtail the future spectrum gap.

D. EFFECT OF SPECTRAL EFFICIENCY GROWTH

Spectrum Efficiency is another great solution for addressing the spectrum gap. The normal average expected growth of spectrum efficiency in 2020 can reach up to 160%; as illustrated in subsection G under section IV. This growth contributes to decreasing the licensed spectrum need to 957 MHz

for 2020; as illustrated in Figure 18. However, there is a possibility of increasing spectrum efficiency up to 200%, which is 2-times more compared to 2015. This can be done by upgrading total networks to LTE and LTE-Advanced systems while considering a high modulation scheme and implementing  $4 \times 4$  MIMO.

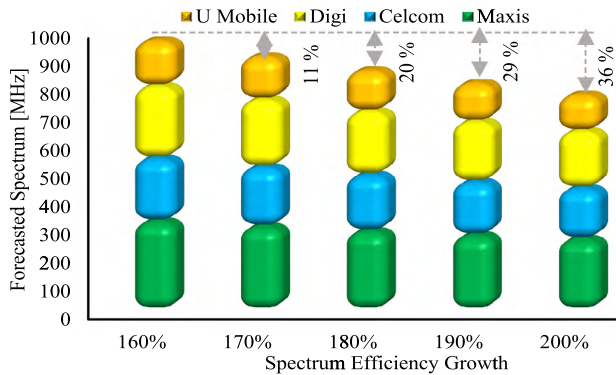

**FIGURE 27.** Effect of enhancing spectrum efficiency for reducing the required spectrum in Malaysia's future.

This upgrade will enhance spectral efficiency, which will contribute to reducing the future spectrum requirement since the spectrum gap possesses an inverse relationship with spectral efficiency. Figure 27 illustrated the effect of the relationship between spectral efficiency and the spectrum gap. From the results, it can be seen that if spectrum efficacy is enhanced up to 200%, the spectrum needed can be reduced from 957MHz to 766 MHz. This will downsize the spectrum gap by 36% for Malaysia in 2020. Thus, operators should consider spectrum efficiency growth as one solution for future spectrum decline, especially if there are no spectrum bands available in the country.

All proposed solutions can be considered to address the spectrum gap in the coming years. However, if operators cannot implement the suggested solution to the maximum, they can implement them partially by considering the cost. For instance, operators can off-load only 25% of mobile data traffic to unlicensed bands which will reduce 45% of the spectrum gap. Moreover, they can increase the number of sites to 250% only, which will reduce the spectrum gap by 43% as compare to the actual prediction in subsection G under section IV. The spectrum efficiency can further be enhanced to 180%, which will provide a 20% reduction of the spectrum gap in 2020. These partial solutions can significantly address the future spectrum gap dilemma.

## VI. CONCLUSION

In this study, a new forecasting spectrum model was developed to estimate the spectrum gap depending on five main input metrics: the CAS, SNG, DTG, ANU and SEG. This model was used to estimate and analyses the spectrum gap for Malaysia in 2020 based on four major MTNs: Maxis, Celcom, Digi and U Mobile. The analysis began by studying the network performance to show the enhancements pro-

vided by 4G over 3G networks. That supplied the comprehension of current MBB performance and the actual user MBB experience in Malaysia. Next, the sites number growth, mobile data traffic growth, average network utilization, spectrum efficiency growth and current spectrum available were presented and discussed to illustrate the radical expansion of these main metrics. Based on this study, it can be concluded that by 2020, mobile data traffic in Malaysia will reach up to 2364.47 Petabytes per year, which is up from 295.72 Petabytes in 2015. That will be almost eight-time more than 2015's traffic. The predictable average sites number and spectrum efficiency growths over the periods 2015 to 2020 will reach up to 167% and 264%, respectively. Based on these estimations, Malaysia will need around 307 MHz of additional spectrum to fulfil the tremendous increase of future data demands. The crucial need of the spectrum gap is becoming a serious issue which must be addressed to fulfil the anticipated data demands. Meeting these data requirements can be achieved by either finding a potential spectrum band, off-loading mobile data traffic to unlicensed bands, increasing sites number growth or enhancing spectral efficiency growth. Implementing these recommendations should help regulators and operators to address the future spectrum gap. To demonstrate, two potential bands can be used to support the explosive traffic increase and higher performance expectations in Malaysia. The candidate frequency bands are available for identifying the spectrum for future development of IMT and IMT-Advanced systems. These two spectrum bands include 700 MHz and 1.4 GHz; which are highly anticipated under WRC-15. In addition, off-loading 50% of mobile data traffic onto Wi-Fi and femtocell networks will reduce mobile data traffic of cellular networks from 2364.47 Petabytes to 745.44 Petabytes. This will slash the required spectrum gap by 50% in 2020 as compared to the year 2015. Also, increasing the sites number growth to 426% will diminish the required licensed spectrum by 57%. These are highly significant results, which resolves the need for further spectrum in 2020. Similarly, enhancing spectrum efficiency up to 200% will reduce the required licensed spectrum in 2020 by around 36%. All proposed solutions can be considered to address the future spectrum gap dilemma. However, if operators cannot implement the suggested solutions to the maximum, they can at least partially implement them, taking the cost into consideration. The main limitations in this developed model can be in the collection of input data from various accurate resources. Whereas, some of the operators and developers will not easily share their historical data with the academic researchers.

## REFERENCES

- [1] S.-Y. Ihm, J.-H. Hur, and Y.-H. Park, "An indexing method to construct unbalanced layers for high-dimensional data in mobile environments," *Wireless Commun. Mobile Comput.*, vol. 2017, pp. 1–13, Nov. 2017, Art. no. 9309181.
- [2] P. Sathyamoorthy, E. C.-H. Ngai, X. Hu, and V. Leung, "Profiling energy efficiency and data communications for mobile Internet of Things," *Wireless Commun. Mobile Comput.*, vol. 2017, pp. 1–15, Nov. 2017, Art. no. 6562915.

- [3] Y. Sun, H. Song, A. J. Jara, and R. Bie, "Internet of Things and big data analytics for smart and connected communities," *IEEE Access*, vol. 4, pp. 766–773, Mar. 2016.
- [4] S. M. R. Islam, D. Kwak, M. H. Kabir, M. Hossain, and K.-S. Kwak, "The Internet of Things for health care: A comprehensive survey," *IEEE Access*, vol. 3, pp. 678–708, Jun. 2015.
- [5] C. Perera, C. H. Liu, S. Jayawardena, and M. Chen, "A survey on Internet of Things from industrial market perspective," *IEEE Access*, vol. 2, pp. 1660–1679, Jan. 2014.
- [6] L. Zhou and H.-C. Chao, "Multimedia traffic security architecture for the Internet of Things," *IEEE Netw.*, vol. 25, no. 3, pp. 35–40, May/Jun. 2011.
- [7] M. A. Feki, F. Kawsar, M. Boussard, and L. Trappeniers, "The Internet of Things: The next technological revolution," *Computer*, vol. 46, no. 2, pp. 24–25, Feb. 2013.
- [8] Z. Sheng, C. Mahapatra, C. Zhu, and V. C. M. Leung, "Recent advances in industrial wireless sensor networks toward efficient management in IoT," *IEEE Access*, vol. 3, pp. 622–637, Jun. 2015.
- [9] S. K. Goudos, P. I. Dallas, S. Chatziefthymiou, and S. Kyriazakos, "A survey of IoT key enabling and future technologies: 5G, mobile IoT, semantic Web and applications," *Wireless Pers. Commun.*, vol. 97, no. 2, pp. 1645–1675, Nov. 2017.
- [10] S. B. Baker, W. Xiang, and I. Atkinson, "Internet of Things for smart healthcare: Technologies, challenges, and opportunities," *IEEE Access*, vol. 5, pp. 26521–26544, 2017.
- [11] M. Khan, B. N. Silva, and K. Han, "Internet of Things based energy aware smart home control system," *IEEE Access*, vol. 4, pp. 7556–7566, Oct. 2016.
- [12] P. P. Ray, M. Mukherjee, and L. Shu, "Internet of Things for disaster management: State-of-the-art and prospects," *IEEE Access*, vol. 5, pp. 18818–18835, 2017.
- [13] C. Zhu, V. C. M. Leung, L. Shu, and E. C.-H. Ngai, "Green Internet of Things for smart world," *IEEE Access*, vol. 3, pp. 2151–2162, Nov. 2015.
- [14] K. Christidis and M. Devetsikiotis, "Blockchains and smart contracts for the Internet of Things," *IEEE Access*, vol. 4, pp. 2292–2303, 2016.
- [15] H. Jung and I.-H. Lee, "Performance analysis of three-dimensional clustered device-to-device networks for Internet of Things," *Wireless Commun. Mobile Comput.*, vol. 2017, pp. 1–10, Nov. 2017, Art. no. 9628565.
- [16] S. Chen, R. Ma, H.-H. Chen, H. Zhang, W. Meng, and J. Liu, "Machine-to-machine communications in ultra-dense networks—A survey," *IEEE Commun. Surveys Tuts.*, vol. 19, no. 3, pp. 1478–1503, 3rd Quart., 2017.
- [17] ETSI, "Machine-to-machine communications (M2M): Functional architecture," Int. Telecommun. Union, Geneva, Switzerland, Tech. Rep. TS 102 690, 2011.
- [18] J. Qiao, X. Shen, J. Mark, Q. Shen, Y. He, and L. Lei, "Enabling device-to-device communications in millimeter-wave 5G cellular networks," *IEEE Commun. Mag.*, vol. 53, no. 1, pp. 209–215, Jan. 2015.
- [19] D. Camps-Mur, A. Garcia-Saavedra, and P. Serrano, "Device-to-device communications with Wi-Fi direct: Overview and experimentation," *IEEE Wireless Commun.*, vol. 20, no. 3, pp. 96–104, Jun. 2013.
- [20] W. A. Thought, *Machine to Machine the Technology of the Future*. Accessed: Aug. 20, 2018. [Online]. Available: <http://www.wipro.com/>
- [21] M. Hutton, "The global M2M market in 2013," Machina Res., White Paper MR-GMM2013, USA, Jan. 2013.
- [22] Y. Miao, Z. Ruan, L. Pan, J. Zhang, and Y. Xiang, "Comprehensive analysis of network traffic data," in *Concurrency and Computation: Practice and Experience*, vol. 30. Hoboken, NJ, USA: Wiley, 2018, no. 5, p. e4181.
- [23] Y. Ma, L. Zhou, Z. Gu, Y. Song, and B. Wang, "Channel access and power control for mobile crowdsourcing in device-to-device underlaid cellular networks," *Wireless Commun. Mobile Comput.*, vol. 2018, pp. 1–13, Jan. 2018, Art. no. 7192840.
- [24] O. Chughtai, N. Badruddin, M. Rehan, and A. Khan, "Congestion detection and alleviation in multihop wireless sensor networks," *Wireless Commun. Mobile Comput.*, vol. 2017, pp. 1–13, Feb. 2017, Art. no. 9243019.
- [25] C. Dehos, J. L. González, A. De Domenico, D. Kténas, and L. Dussopt, "Millimeter-wave access and backhauling: The solution to the exponential data traffic increase in 5G mobile communications systems?" *IEEE Commun. Mag.*, vol. 52, no. 9, pp. 88–95, Sep. 2014.
- [26] B.-S. Kim, H. Park, K. H. Kim, D. Godfrey, and K.-I. Kim, "A survey on real-time communications in wireless sensor networks," *Wireless Commun. Mobile Comput.*, vol. 2017, pp. 1–14, Oct. 2017, Art. no. 1864847.
- [27] Y. Zhao, W. Li, J. Wu, S. Lu, and B. Chen, "Compressed RSS measurement for communication and sensing in the Internet of Things," *Wireless Commun. Mobile Comput.*, vol. 2017, pp. 1–11, Aug. 2017, Art. no. 6345316.
- [28] A. Abdelgawad and K. Yelamathi, "Internet of Things (IoT) platform for structure health monitoring," *Wireless Commun. Mobile Comput.*, vol. 2017, pp. 1–11, Oct. 2017, Art. no. 6560797.
- [29] B. R. Stojkoska, K. Trivodaliev, and D. Davcev, "Internet of Things framework for home care systems," *Wireless Commun. Mobile Comput.*, vol. 2017, pp. 1–10, Feb. 2017, Art. no. 8323646.
- [30] J. Liu, F. Wang, X. Ma, and Z. Yang, "Recent advances in wireless communication protocols for Internet of Things," *Wireless Commun. Mobile Comput.*, vol. 2017, pp. 1–2, Nov. 2017, Art. no. 8791485.
- [31] J. Greenough, "The 'Internet of Things' will be the World's most massive device market and save companies billions of dollars," *Available via Business Insider*, vol. 2, pp. 1–15, Apr. 2015.
- [32] L. Atzori, A. Iera, and G. Morabito, "The Internet of Things: A survey," *Comput. Netw.*, vol. 54, no. 15, pp. 2787–2805, Oct. 2010.
- [33] F. C. Pinto, P. Chainho, N. Pássaro, F. Santiago, D. Corujo, and D. Gomes, "The business of things architecture," *Trans. Emerg. Telecommun. Technol.*, vol. 24, no. 4, pp. 441–452, 2013.
- [34] J.-H. Choi, J. Park, H. D. Park, and O.-G. Min, "DART: Fast and efficient distributed stream processing framework for Internet of Things," *ETRI J.*, vol. 39, no. 2, pp. 202–212, 2017.
- [35] C. Perera, A. Zaslavsky, P. Christen, and D. Georgakopoulos, "Sensing as a service model for smart cities supported by Internet of Things," *Trans. Emerg. Telecommun. Technol.*, vol. 25, no. 1, pp. 81–93, 2014.
- [36] K. Rose, S. Eldridge, and L. Chapin, "The Internet of Things (IoT): An overview—understanding the issues and challenges of a more connected world," *Internet Soc.*, to be published.
- [37] L. Zhao, L. Zhao, Q. Song, C. Zhao, and B. Li, "Rain attenuation prediction models of 60 GHz based on neural network and least squares-support vector machine," in *Proc. 2nd Int. Conf. Commun., Signal Process., Syst., B. Zhang, J. Mu, W. Wang, Q. Liang, and Y. Pi, Eds.*, Cham, Switzerland: Springer, 2014, pp. 413–421.
- [38] Machina Research. *Global M2M Market To Grow To 27 Billion Devices, Generating USD 1.6 Trillion Revenue in 2024*. [Online]. Available: <https://machinaresearch.com>
- [39] A. Gupta and E. R. K. Jha, "A survey of 5G network: Architecture and emerging technologies," *IEEE Access*, vol. 3, pp. 1206–1232, Jul. 2015.
- [40] Y. Huo, X. Dong, and W. Xu, "5G cellular user equipment: From theory to practical hardware design," *IEEE Access*, vol. 5, pp. 13992–14010, 2017.
- [41] M. Marjani et al., "Big IoT data analytics: Architecture, opportunities, and open research challenges," *IEEE Access*, vol. 5, pp. 5247–5261, 2017.
- [42] G. A. Akpakwu, B. J. Silva, G. P. Hancke, and A. M. Abu-Mahfouz, "A survey on 5G networks for the Internet of Things: Communication technologies and challenges," *IEEE Access*, vol. 6, pp. 3619–3647, 2018.
- [43] D. Zhang, Z. Zhou, Z. Zhu, and S. Mumtaz, "Energy efficiency analysis of ICN assisted 5G IoT system," *Wireless Commun. Mobile Comput.*, vol. 2017, pp. 1–9, Dec. 2017, Art. no. 6579467.
- [44] Y. Lim and J. Park, "Efficient data forwarding for machine type communications in Internet of Things networks," *Wireless Commun. Mobile Comput.*, vol. 2017, pp. 1–6, Dec. 2017, Art. no. 7865342.
- [45] L. Lopacinski, M. Brzozowski, and R. Kraemer, "Data link layer considerations for future 100 Gbps terahertz band transceivers," *Wireless Commun. Mobile Comput.*, vol. 2017, pp. 1–11, Oct. 2017, Art. no. 3560521.
- [46] J. Winkler, C. P. J.-W. Kuklinski, and R. Moser, "Decision making in emerging markets: The Delphi approach's contribution to coping with uncertainty and equivocality," *J. Bus. Res.*, vol. 68, no. 5, pp. 1118–1126, 2015.
- [47] K. Kunisawa and Y. Horibe, "Forecasting international telecommunications traffic by the data translation method," *Int. J. Forecasting*, vol. 2, no. 4, pp. 427–434, 1986.
- [48] C. Katris and S. Daskalaki, "Combining time series forecasting methods for Internet traffic," in *Stochastic Models, Statistics and Their Applications*. New York, NY, USA: Springer, 2015, pp. 309–317.
- [49] S. Lee, C. Cho, E.-K. Hong, and B. Yoon, "Forecasting mobile broadband traffic: Application of scenario analysis and Delphi method," *Expert Syst. Appl.*, vol. 44, pp. 126–137, Feb. 2016.
- [50] R. Fildes and V. Kumar, "Telecommunications demand forecasting—A review," *Int. J. Forecasting*, vol. 18, no. 4, pp. 489–522, 2002.

- [51] AM Report. *Wireless Network Data Traffic in Emerging Asia-Pacific: Trends and Forecasts 2015–2020*. [Online]. Available: [www.analysismason.com](http://www.analysismason.com)
- [52] GSMA Intelligence. (2016). *Malaysia Markets Data, 3G and 4G mobile technologies and United Nations (World Population Prospects)*. [Online]. Available: [www.gsma.com](http://www.gsma.com)
- [53] I. Z. Kovács, P. Mogensen, B. Christensen, and R. Jarvela, "Mobile broadband traffic forecast modeling for network evolution studies," in *Proc. IEEE Veh. Technol. Conf. (VTC Fall)*, Sep. 2011, pp. 1–5.
- [54] B. Gompertz, "On the nature of the function expressive of the law of human mortality, and on a new mode of determining the value of life contingencies," *Phil. Trans. Roy. Soc. London*, vol. 115, pp. 513–583, Jan. 1825.
- [55] *Methodology for Calculation of Spectrum Requirements for the Terrestrial Component of International Mobile Telecommunications*, document Recommendation ITU-R M.1768-1, 2013.
- [56] *Future Spectrum Requirements Estimate for Terrestrial IMT*, document Recommendation ITU-R M.2290-0, 2013.
- [57] *Traffic Forecasts and Estimated Spectrum Requirements for the Satellite Component of IMT 2000 and Systems Beyond IMT-2000 for the Period 2010 to 2020*, document Recommendation ITU-R M.2077-0, 2006.
- [58] Federal Communications Commission. (2010). *Mobile Broadband: The Benefits of Additional Spectrum*. [Online]. Available: <https://www.fcc.gov>
- [59] B. Williamson. (2014). *Do You Need a Mobile Data Forecast to Estimate Spectrum Demand*. [Online]. Available: <https://www.plumvoice.com/>
- [60] ACMA, "Beyond 2020—A spectrum management strategy to address the growth in mobile broadband capacity," Australian Communications and Media Authority, ACMA2015-SM, 2015, pp. 1–68.
- [61] *Consulting Report Prepared For Huawei Global Wireless Spectrum Research & Analysis*, Pyramid Res., Huawei, Shenzhen, China, 2016.
- [62] (2016). *Cisco Visual Networking Index: Global Mobile Data Traffic Forecast Update, 2016–2021 White Paper*. [Online]. Available: <http://goo.gl/y1TuVx>
- [63] *Ericsson Mobility Report On the Pulse of the Networked Society* Ericsson, Ericsson, Stockholm, Sweden, Jun. 2015.
- [64] Q. Heng, "MBB 2020: For a better connected world in asia pacific," in *Proc. 2nd AP Spectrum Manage. Conf.*, Bangkok, Thailand, Apr. 2016, pp. 1–6.
- [65] *Ericsson Mobility Report on the Pulse of the Networked Society*, Ericsson, Stockholm, Sweden, Nov. 2015.
- [66] *Ericsson Mobility Report on South East Asia and Oceania*, Ericsson, Stockholm, Sweden, Nov. 2015.
- [67] ReportBuyer. *Global Mobile Cloud Market—By User Type, End User Industry, Vendors and Geography—Forecasts and Trends (2015–2020)*. Accessed: Aug. 20, 2018. [Online]. Available: <https://www.reportbuyer.com/product/3281860/>
- [68] *Estimate of Spectrum Requirement*, document ITU-R M.2077-0, 2017.
- [69] C. Bazelon and G. McHenry, "Substantial licensed spectrum deficit (2015–2019): Updating the FCC's mobile data demand projections," The Brattle Group, Cambridge, MA, USA, Tech. Rep., FCC-SLSD2015, Jun. 2015, vol. 23, pp. 1–20.
- [70] B. Williamson. (Jan. 2012). *Mobile Data Growth—Too Much Of A Good Thing, Plum Insight Whitepaper*. Accessed: Sep. 30, 2018. [Online]. Available: [http://www.plumconsulting.co.uk/pdfs/Plum\\_Insight\\_Jan2012\\_Mobile\\_data\\_growth\\_-\\_too\\_much\\_of\\_a\\_good\\_thing.pdf](http://www.plumconsulting.co.uk/pdfs/Plum_Insight_Jan2012_Mobile_data_growth_-_too_much_of_a_good_thing.pdf)
- [71] A. Riaz, *Spectrum Forecasting for Future Use: Methods & Techniques*, document ITU-MCMC-ITP2015-01, ITU-MCMC International Training Program, Kuala Lumpur, Malaysia, 2015.
- [72] M. Karimzadeh, H. van den Berg, R. D. O. Schmidt, and A. Pras, "Quantitative comparison of the efficiency and scalability of the current and future LTE network architectures," *Wireless Commun. Mobile Comput.*, vol. 2017, pp. 1–20, Nov. 2017, Art. no. 3938545.
- [73] WCC, "Perspectives on Malaysia mobile broadband development 2020," Wireless Communication Centre (WCC), Univ. Teknologi Malaysia, White Paper, 2017. [Online]. Available: [https://www.malaysianwireless.com/wp-content/uploads/2017/08/UTM\\_Perspective-on-Malaysia-Mobile-Broadband-Development-2020.pdf](https://www.malaysianwireless.com/wp-content/uploads/2017/08/UTM_Perspective-on-Malaysia-Mobile-Broadband-Development-2020.pdf)
- [74] MCMC. (2016). *MCMC Annual Reports*. [Online]. Available: <http://www.mcmc.gov.my>
- [75] *Spectrum Gap Calculation Method*, Huawei MLab, Huawei, China, Jan. 2017.
- [76] MCMC. *Spectrum Allocation*. Accessed: Jul. 30, 2018. [Online]. Available: <https://www.mcmc.gov.my/spectrum/spectrum-allocation-list/spectrum-allocation>
- [77] Plum. *Global Momentum and Economic Impact of the 1.4/1.5 GHz Band for IMT*. Accessed: Sep. 30, 2018. [Online]. Available: <https://www.gsma.com/>



**IBRAHEEM SHAYEA** received the B.Sc. degree in electronic engineering from the University of Diyala, Baqubah, Iraq, in 2004, and the M.Sc. degree in computer and communication engineering and the Ph.D. degree in mobile communication engineering from The National University of Malaysia, Universiti Kebangsaan Malaysia (UKM), Malaysia, in 2010 and 2015, respectively. From 2011 to 2014, he was a Research and Teaching Assistant with UKM. From 2016 to 2018, he was with the Wireless Communication Center, University of Technology Malaysia, Malaysia, where he was a Research Fellow. He is currently a Research Fellow with Istanbul Technical University, Istanbul, Turkey.



**MARWAN HADRI AZMI** received the B.Eng. degree (Hons.) in electrical and telecommunications from Universiti Teknologi Malaysia, Johor Bahru, Malaysia, in 2003, the M.Sc. degree in communications and signal processing from the Imperial College of Science, Technology and Medicine, University of London, in 2005, and the Ph.D. degree from the University of New South Wales, Australia, in 2012. From 2012 to 2014, he spent his sabbatical leave of absence with McGill University, Canada, working in the funded project by RIM Inc., and NSERC, *Cooperative Spectrum Sensing and Information Relaying in Cognitive Wireless Communications*. He is currently a Senior Lecturer with the Wireless Communication Centre, Universiti Teknologi Malaysia. His research interests include mobile and wireless communications, communication theory, error control coding, relay networks, spectrum sensing for cognitive radio, and iterative receiver.



**THAREK ABD. RAHMAN** received the B.Sc. degree in electrical and electronic engineering from the University of Strathclyde, U.K., in 1979, the M.Sc. degree in communication engineering from UMIST, Manchester, U.K., and the Ph.D. degree in mobile radio communication engineering from the University of Bristol, U.K., in 1988. He is currently the Director of the Wireless Communication Centre, Universiti Teknologi Malaysia, and also a Professor with the Faculty of Electrical Engineering. He has also conducted various short courses related to mobile and satellite communication to the Telecommunication Industry and Government body, since 1990. He has a teaching experience in the areas of mobile radio, wireless communication system, and satellite communication. He has published more than 120 papers related to wireless communication in national/international journal and conference. His research interests include radio propagation, antenna and RF design, and indoors and outdoors wireless communication.



**MUSTAFA ERGEN** received the B.S. degree (Hons.) in electrical engineering as valedictorian from Middle East Technical University with 4.0/4.0 GPA, in 1896, and the M.S. and Ph.D. degrees in electrical engineering, the M.A. degree from international studies, and MOT Program from the HAAS Business School, University of California (UC) at Berkeley.

He was a National Semiconductor Fellow (currently TI) with UC Berkeley, where he co-founded the Distributed Sensing Lab, focusing on statistical sensor intelligence and vehicular communication. He is currently a Professor of electrical engineering with Istanbul Technical University, the President of venture funded Ambeent Inc., focusing 5G and the Artificial Intelligence and also the Chief Technology Advisor with Türk Telekom. He is also an Adjunct Associate Professor with Koç University. He co-founded Silicon Valley startup WiChorus Inc., to focus on 4G technologies and company is acquired by Tellabs (now Coriant) for U.S. \$200 million. He has more than 40 patent applications, many publications, and authored three books: 1) *Girişimci Kapital: Silikon Vadisi Tarihi ve Startup Ekonomisi* (2nd Edition-KÜY, 2017); 2) *移动宽带系统包括WiMAX和LTE* (PHEI, 2011); 3) *Mobile Broadband: Including WiMAX and LTE* (Springer, 2009); and 4) *Multi Carrier Digital Communications: Theory and Applications of OFDM* (Springer, 2004). He is a National Delegate in 5G Infrastructure Association and Horizon2020 ICT Funding Programs of European Union and advisor with Berkeley Program on Entrepreneurship and Development. He served in the Board of Trustees of the TOBB University of Economics and Technology and was cohost in TV show on BloombergHT about entrepreneurship.



**CHUA TIEN HAN** received the B.Sc. degree (Hons.) in electrical engineering and the M.Eng. degree in wireless engineering from Universiti Teknologi Malaysia, in 2003 and 2007, respectively. He is currently pursuing the Ph.D. degree with the Computer Laboratory, University of Cambridge. He was a Tutor with the Faculty of Electrical Engineering, Universiti Teknologi Malaysia, from 2005 to 2007, where he has been a Lecturer, since 2007. His research interests include broad-

band fixed wireless access systems, radio propagation, channel modeling, and measurement.



**ARSANY ARSAD** received the B.Eng. degree in electrical-telecommunication and the M.Eng. degree in electrical from Universiti Teknologi Malaysia (UTM), Johor Bahru, in 2009 and 2013, respectively. He is currently a Research Officer with the Wireless Communication Centre, UTM, International Campus Kuala Lumpur. He actively involved in university research projects and collaboration and consultation projects with industry. His research interests include radio propagation and mobile wireless communication.

...