

Received December 11, 2018, accepted December 21, 2018, date of publication January 1, 2019, date of current version January 29, 2019.

Digital Object Identifier 10.1109/ACCESS.2018.2890533

A Novel Modified Sine-Cosine Optimized MPPT Algorithm for Grid Integrated PV System under Real Operating Conditions

**SANJEEVIKUMAR PADMANABAN¹, (Senior Member, IEEE),
NEERAJ PRIYADARSHI², (Member, IEEE), JENS BO HOLM-NIELSEN¹,
MAHAJAN SAGAR BHASKAR³, (Member, IEEE),
FAROOQUE AZAM⁴, (Member, IEEE),
AMARJEET KUMAR SHARMA², (Member, IEEE),
AND EKLAS HOSSAIN⁵, (Senior Member, IEEE)**

¹Center for Bioenergy and Green Engineering, Aalborg Universitet, 6700 Esbjerg, Denmark

²Department of Electrical Engineering, Birsa Institute of Technology (Trust), Ranchi 835217, India

³Department of Electrical Engineering, Qatar University, Doha, Qatar

⁴School of Computing and Information Technology, REVA University, Bengaluru 560064, India

⁵Department of Electrical Engineering and Renewable Energy, Oregon Institute of Technology, Klamath Falls, OR 97601, USA

Corresponding author: Mahajan Sagar Bhaskar (sagar25.mahajan@gmail.com)

ABSTRACT This research work presents a modified sine-cosine optimized maximum power point tracking (MPPT) algorithm for grid integration. The developed algorithm provides the maximum power extraction from a photovoltaic (PV) panel and simplified implementation with a benefit of high convergence velocity. Moreover, the performance and ability of the modified sine-cosine optimized (MSCO) algorithm is equated with recent particle swarm optimization and artificial bee colony algorithms for comparative observation. Practical responses is analyzed under steady state, dynamic, and partial shading conditions by using dSPACE real controlling board laboratory scale hardware implementation. The MSCO-based MPPT algorithm always shows fast convergence rate, easy implementation, less computational burden and the accuracy to track the optimal PV power under varying weather conditions. The experimental results provided in this paper clearly show the validation of the proposed algorithm.

INDEX TERMS Artificial bee colony, sine-cosine optimized, maximum power point tracking, photovoltaic, particle swarm optimization.

I. INTRODUCTION

Because of the depletion of conventional energy sources, the demands of renewable energy sources are increasing day by day [1]. Among all renewable sources, Photovoltaic Generation (PVG) has widely considered renewable technology to produce electrical power [2]. As per latest global solar demand monitor, the global solar installed capacity has been expressed 104 GW in 2018. PV modules have non-linear I-V nature and its output depends on sun insolation, ambient temperature and loading conditions which results necessity to control Maximum Power Point (MPP) operating region for peak power extraction from PV system [3].

The Perturb & Observed (P&O) algorithm has simpler execution and there is no requirement of PV modules statistics [4]. Nevertheless, PV tracking speed is the main problem

under maximum power point (MPP) operation, which results loss in power near to MPP region because of high oscillations around this operating point. Furthermore, the PV tracking efficiency under varying climate condition is another issue of this algorithm. The Hill Climbing (HC) [5] algorithm produces perturbation in duty cycle of switched mode power converter, which produces more oscillations nearer to MPP region and power losses. The incremental conductance (INC) has been invented to reduce maximum power point MPP perturbation [6]. However, practical implementation of INC method has high complexity and hardware responses reveal that under steady state conditions, oscillation around MPP region is still present. The intelligent technique, Fuzzy Logic Control (FLC) [7] employed with fuzzy inference rule and gradient based PV curve, which provides more PV tracked

accuracy with less MPP region oscillations. However, complex implementation and slow convergence speed is major issue of this algorithm. Artificial Neural Network (ANN) [8] is another artificial intelligence based MPPT technique, which provides training to non-linear PV characteristics and has fast convergence velocity with accurate design under changing weather conditions. However, implementation with microcontroller based real time interface is the main issue of this algorithm. Furthermore, retraining is another problem, whenever PV parameters are varying. These drawbacks in FLC and ANN algorithms are motivating the researchers to work on different evolutionary algorithms. The classical Particle Swarm Optimization (PSO) has simpler design with easier execution for global power point tracking [9]. However, in this method, convergence is possible with more number of iterations, which results deviation of more speed-updated particles and has slow convergence velocity. To remove these issues in classical PSO techniques, designers have proposed modified PSO algorithm [10] said deterministic PSO, which has better performance compared to classical PSO. However, this still having issues because of presence of its local mode. Artificial Bee Colony (ABC) is another optimization-based algorithm [11]. At the time of sequent handling, ABC performance has low convergence speed, which can be enhanced by increment of size of population and iteration numbering. Nevertheless, it generates additional computational concern with process velocity retardation.

Several optimized MPPT method based on soft computing techniques, such as Jaya, Ant Colony Optimization (ACO) etc. [12] have implementation complexities because of large size of population as well as crowd based searching regulation. Jaya based MPPT algorithm [13] provides best solution by neglecting worst previous parameter in every iteration which results slow tracking velocity as well as lacking to search global victory position. Grey Wolf Optimization (GWO) [14] works on prey tracking encircle and attacked process for global searching. However, under sharp global maximum power point, the GWO algorithm gets confused and local maximum power point arises.

To achieve world's power requirement, integration of renewable energy sources to the electrical grid is very important and for this inverter control design is required. The inverter controllers are needed to synchronize and injected sine wave inverter current to utility grid. Predictive controller [15], Sine Pulse Width Modulation (SPWM) [16], hysteresis based inverter controller [17], Space Vector Pulse Width Modulation (SVPWM)[18], Fuzzy Space Vector Pulse Width Modulation (FSVPWM) [19] have been discussed to generate gate signal for firing inverter switches. In case of predictive controller, the output depends on loading conditions that has design complexities and has slow system responses. Moreover, varying switched frequency and constant bands are the major issues of hysteresis based inverter control strategies. The SVPWM is better-mapped method for inverter control and has lower switched losses with low harmonic contents as well. However, fixed DC-link control

with low ripple contents and non-linearity are the major issues of this classical SVPWM method. The Fuzzy Space Vector Pulse Width Modulation (FSVPWM) delivers fast dynamic DC-link utilization with reduced harmonic contents and manages non-linearity of the PV power system. However, practical implementation of FSVPWM using dSPACE hardware interface is complex.

In this research work, ZETA converter of 4th order buck-boost converter is selected for MPPT functioning [20]. It works as a power factor correction device, which works in continuous conducting modes. This proposed converter has high stepped voltage design with lower voltage stress. Compared to SEPIC (Single Ended Primary Inductance Converter) and CUK converter, the ZETA converter comprises continuous output current with lower ripple in output [21]. The proposed zeta converter produced lower ripple in output and minimizes the design complexities and rental of buck/boost switched converter with simpler compensation. For minimizing PV modules efficiency, the PV panels should be associated with switched mode power converter. Kumar *et al.* [22] has discussed hybrid Cauchy and sine-cosine optimization algorithm for PV battery charging applications. In this method sine-cosine, based optimization technique produces population, which is followed by MPP achievement region with employed Cauchy algorithms and has high convergence velocity. This hybrid algorithm provides effective PV battery charging under uniform and non-uniform implementation using dSPACE platform. This algorithm has design complexities and has high computational burden interfaced to microcontroller based system. Sahu and Londhe [23] has implemented sine-cosine optimization based method for reduction of harmonics in 5-level inverter system. This method provides high convergence velocity with reduced harmonic contents. However, the MPPT operation has not been discussed in this paper and has total harmonic distortion (THD) of 17.1%, which does not satisfy the IEEE 519 standard. Only these two papers have been discussed by any researchers for application of sine-cosine optimization based algorithm for renewable energy and power electronics based system.

To overcome aforesaid drawbacks, in this manuscript a novel stochastic Modified Sine-Cosine Optimized (MSCO) based MPPT method with Lyapunov stability based Adaptive Fuzzy Sliding Mode Control (AFSMC). Inverter control strategy has been implemented practically using dSPACE interface which works under every weather condition. The recentness of MSCO MPPT and AFSMC as inverter control is that these algorithms have neither implemented nor been demonstrated in any past research and under same operating conditions. Additionally, the MSCO based proposed MPPT technique has been equated with PSO and ABC methods and performance has been validated using hardware implementation with dSPACE real time board. The proposed AFSMC based inverter strategy is the combination of FLC and Sliding Mode Controller (SMC) methods in which Lyapunov stability criteria has been employed to obtain high precise and robust

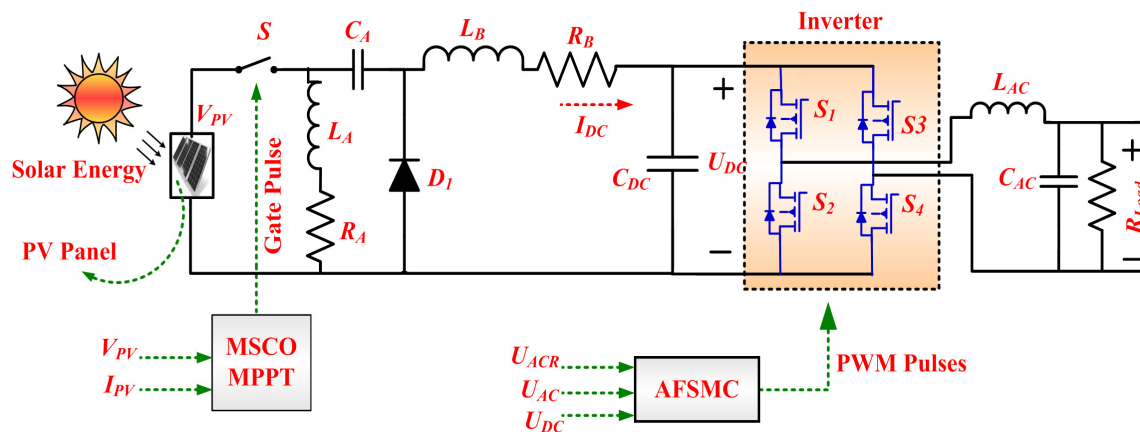

FIGURE 1. Overall schematic of MSCO based MPPT for grid integration.

response of the PV system. Moreover, the proposed controls strategy is implemented in practically which has simple hardware requirement and adapts easily under changing environmental conditions.

II. OVERALL STRUCTURE OF THE PROPOSED PV GRID INTEGRATION

This paper deals the MSCO based MPPT controller for PV grid integration. In this research work, zeta converter of 4th order buck-boost converter is employed for MPPT functioning and acts as an interface between PV module and inverter. The proposed AFSMC based inverter strategy is the combination of FLC and SMC methods in which Lyapunov stability criteria has been employed to obtain high precise and robust response of the PV system which is responsible for unity power factor operation. Fig.1 demonstrates the MSCO and AFSMC employed control system for PV grid integration.

A. PV MODULE MATHEMATICAL MODELING

The basic PV array is formed by series and parallel combination of PV cell, which is represented by a current source and diode in parallel. Fig.2 presented PV cell can be modeled mathematically as [24],

$$I_{OUT} = I_{PHOTON} - I_{DIODE} - I_{PR} \tag{1}$$

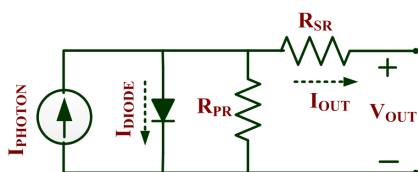

FIGURE 2. Basic Model of PV cell.

Also, I_{PHOTON} can be expressed mathematically as [22]:

$$I_{PHOTON} = \frac{G_A}{G_{REF}} [I_{RS_REF} + P_{SCT} (T_C - T_{C_REF})] \tag{2}$$

$$I_{DIODE} = I_{RS} \left[e^{\frac{Q(V_{OUT} + R_{SR} * I_{OUT})}{\beta K T}} - 1 \right] \tag{3}$$

$$I_{PR} = \frac{1}{R_{PR}} (V_{OUT} + R_{SR} * I_{OUT}) \tag{4}$$

$$I_{RS} = \frac{I_{RS_REF}}{\left(e^{\frac{Q V_{open}}{N_S * N * \alpha * T_C}} - 1 \right)} \tag{5}$$

The output current can be expressed mathematically with abbreviations [22] as,

$$I_{OUT} = I_{PHOTON} - I_{RS} \left(e^{\frac{Q(V_{OUT} + R_{SR} * I_{OUT})}{\beta K T}} - 1 \right) - \frac{1}{R_{PR}} (V_{OUT} + R_{SR} * I_{OUT}) \tag{6}$$

B. ZETA CONVERTER DESIGN AND MODELING

The zeta converter in continuous conduction mode is shown in Fig. 3. The converter works in two states; one when switch is turned ON and another when switch is turned OFF. The power circuit of zeta converter comprises diode, switch, two inductors (L_A, L_B), two capacitors (C_A, C_B), internal resistances (R_A, R_B) with R_{Load} .

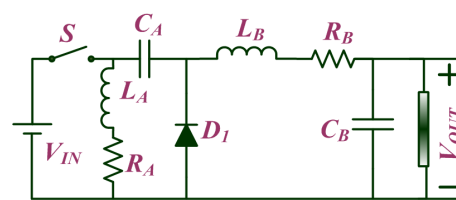

FIGURE 3. Power circuit of ZETA converter.

When switch S is turned ON, inductor L_A and L_B are charged and capacitor C_A is discharged. The equivalent circuitry for ON state is shown in Fig. 4(a) and the mathematical equation is obtained as follows,

$$\left. \begin{aligned} I_{L_A} &= X_1, & I_{L_B} &= X_2 \\ V_{C_A} &= X_3, & V_{C_B} &= X_4 \end{aligned} \right\} \tag{7}$$

$$\left. \begin{aligned} \frac{dI_{L_A}}{dt} &= \frac{1}{L_A} V_{IN} - \frac{R_A}{L_A} I_{L_A}, & \frac{dV_{C_A}}{dt} &= -\frac{1}{C_A} I_{L_B} \\ \frac{dI_{L_B}}{dt} &= \frac{1}{L_B} V_{C_A} + \frac{1}{L_B} V_{IN} - \frac{R_B}{L_B} I_{L_B} - \frac{1}{L_B} V_{C_B} \\ \frac{dV_{C_B}}{dt} &= \frac{1}{C_B} I_{L_B} - \frac{1}{C_B R_{Load}} V_{C_B} \end{aligned} \right\} \quad (8)$$

When switch S is turned OFF, inductors (L_A, L_B) gets discharged. The capacitor C_A is charged from inductor L_A and at the same time inductor L_B is discharged through load R_{Load} and diode D_1 . The equivalent circuitry for OFF state is shown in Fig. 4(b) and the mathematical equation is obtained as follows,

$$\left. \begin{aligned} \frac{dI_{L_A}}{dt} &= \frac{R_A}{L_A} I_{L_A} - \frac{1}{L_A} V_{C_A} \\ \frac{dV_{C_A}}{dt} &= \frac{1}{C_A} I_{L_A}, & \frac{dI_{L_B}}{dt} &= -\frac{1}{L_B} V_{C_B} - \frac{R_B}{L_B} I_{L_B} \\ \frac{dV_{C_B}}{dt} &= \frac{1}{C_B} I_{L_B} - \frac{1}{R_{Load} * C_B} V_{C_B} \end{aligned} \right\} \quad (9)$$

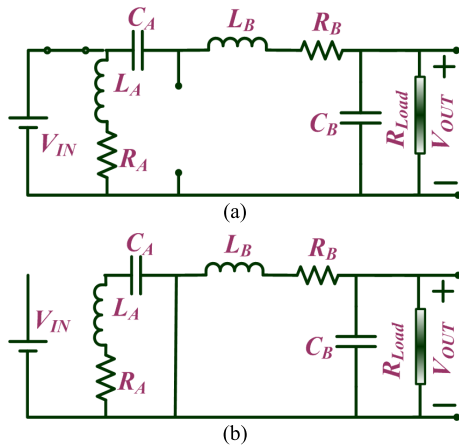

FIGURE 4. Equivalent circuit of ZETA converter (a) ON state, (b) OFF state.

Combining ON, OFF state equation, and following, state space equation is obtained as follows (10) and (11), as shown at the bottom of this page.

$$\left[\begin{matrix} \dot{X}_1 \\ \dot{X}_2 \\ \dot{X}_3 \\ \dot{X}_4 \end{matrix} \right] = \left[\begin{matrix} \frac{R_A}{L_A} & 0 & \frac{d-1}{L_A} & 0 \\ 0 & -\frac{R_B}{L_B} & \frac{d}{L_B} & -\frac{1}{L_B} \\ \frac{1-d}{C_A} & -\frac{d}{C_A} & 0 & 0 \\ 0 & \frac{1}{C_B} & 0 & -\frac{1}{R_{Load} C_B} \end{matrix} \right] \left[\begin{matrix} X_1 \\ X_2 \\ X_3 \\ X_4 \end{matrix} \right] + \left[\begin{matrix} \frac{d}{L_A} \\ \frac{d}{L_B} \\ 0 \\ 0 \end{matrix} \right] U \quad (10)$$

$$Y = \left[\begin{matrix} 0 & 0 & 0 & 0 \end{matrix} \right] \left[\begin{matrix} X_1 \\ X_2 \\ X_3 \\ X_4 \end{matrix} \right] \quad (11)$$

In addition, ripple inductor current and ripple capacitor voltage can be mathematically as:

$$\left. \begin{aligned} \Delta I_{L_A} &= \frac{dV_{IN}}{f_{switching} \times L_A}, & \Delta I_{L_B} &= \frac{dV_{IN}}{f_{switching} \times L_B} \\ \Delta V_{C_A} &= \frac{dV_{IN}}{8f_{switching}^2 \times C_A \times L_A}, \\ \Delta V_{C_B} &= \frac{dV_{IN}}{8f_{switching}^2 \times C_B \times L_B} \end{aligned} \right\} \quad (12)$$

Critical values of inductors and capacitors can be expressed mathematically as:

$$\left. \begin{aligned} L_A &\geq \frac{(1-d)^2 R_{Load}}{2df_{switching}}, & L_B &\geq \frac{(1-d)^2 R_{Load}}{2f_{switching}} \\ C_A &\geq \frac{d^2}{8f_{switching} \times (1-d) \times R_{Load}}, \\ C_B &\geq \frac{1}{8f_{switching} \times R_{Load}} \end{aligned} \right\} \quad (13)$$

Hardware implementation is done and designed parameters are shown in Table 1.

TABLE 1. ZETA converter parameters.

Parameters	Values
Inductors (L_A, L_B)	0.6 mH
Capacitors (C_A, C_B)	0.8mF, 0.9mF
$f_{switching}$	6 kHz
Ripple Inductor currents ($\Delta I_{L_A} = \Delta I_{L_B}$)	2 A
Ripple capacitors, $\Delta V_{C_A} = \Delta V_{C_B}$	5×10^{-2} V

III. MODIFIED SINE-COSINE OPTIMIZED (MSCO) MPPT

In this MSCO method, the optimized search is carried out with varying sine/cosine trigonometric parameters. Initially, SCO method generates small size of population and movement is possible to achieve best outcome with the application of sine-cosine trigonometric function. Mirjalili has invented SCO algorithm for solving optimization-based problems [25]. This stochastic optimized algorithm provides population based random search to obtain optimal solution based

on fitness function calculation in the every iteration. Exploration as well as exploitation can be balanced to achieve global maxima with the help of SCO algorithm, which has rapid convergence velocity. Mathematically, the updated position for searched particle can be expressed as

$$\left. \begin{aligned} R_i^T(j+1) &= R_i^T(j) + S_1 \sin(S_2) |S_3 Q_i^T - R_i^T(j)|, S_4 < 0.5 \\ &= R_i^T(j) + S_1 \cos(S_2) |S_3 Q_i^T - R_i^T(j)|, S_4 \geq 0.5 \end{aligned} \right\} \quad (14)$$

where, $R_i^T(j)$ is j^{th} searched particle's position in the i^{th} dimension, S_1 is controlling parameters, T is No. of iteration, S_2, S_3, S_4 random parameter, Q_i^T is i^{th} dimension destination position. In addition, S_1 controlling parameter explains the mobility orientation under inside or outside location between target and solution that is calculated mathematically as:

$$S_1 = A - T \frac{A}{T_M} \quad (15)$$

where, A denotes constant T is present iteration and $T_M = \text{iteration}^{\text{max}}$.

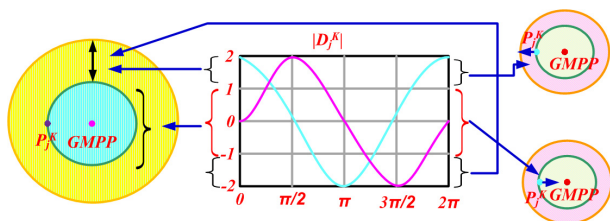

FIGURE 5. SCO based population trajectory.

Fig.5 depicts the SCO based population trajectory which describes the mobility of fitness values as well as parameters location and updated power (P_j^k) corresponds to updated duty ratio (D_j^k). The movement of fitness value becomes close to global maxima when trigonometrically sine-cosine function lies in $[-1, 1]$ interval and exploitation of searched dimension is possible. On the other hand, when sine-cosine function not lies in the interval $[-1, 1]$, the fitness value deviation from global maxima is obtained and exploration of searched dimension is possible.

In this proposed work, the two parameters S_1 and inertia weight can be modified to obtain the high convergence velocity as well as high précised solution. S_1 controlling parameter describes the global exploration to local development transformation. As S_1 increases, global searched potential also increases. In addition, with the decrement in S_1 , local development capability decreases. Therefore, in this proposed work, S_1 can be redesigned using exponential decreasing method. The linear decreasing strategy is adopted to redesign the inertia weight.

The modified position of searched particle becomes:

$$\left. \begin{aligned} R_i^T(j+1) &= \omega(T).R_i^T(j) + S_1 \sin(S_2) |S_3 Q_i^T - R_i^T(j)|, S_4 < 0.5 \\ &= \omega(T).R_i^T(j) + S_1 \cos(S_2) |S_3 Q_i^T - R_i^T(j)|, S_4 \geq 0.5 \end{aligned} \right\} \quad (16)$$

$$\omega(T) = \omega^{\text{max}} - \left(\omega^{\text{max}} - \omega^{\text{min}} \right) \cdot \frac{T}{T_M} \quad (17)$$

$$S_1(T) = A \cdot e^{-T/T_M} \quad (18)$$

where, $\omega(T)$ is inertia weight, ω^{max} and ω^{min} is maximum and minimum inertia weight, the values of $\omega(T)$ and $S_1(T)$ increases in initial stage of iteration which results exploration and $\omega(T)$ and $S_1(T)$ decreases at the end iteration and which results local development of MSCO algorithm.

A. INVERTER CONTROLLER-ADAPTIVE FUZZY SLIDING MODE CONTROLLER

Sliding mode controls provides non-linear controllability in which grid integrated inverter works as tracked components and has objective to confirm grid reference voltage tracking. Fig.6 depicts the proposed Adaptive Fuzzy Sliding Mode Control (AFSMC) in which integral sliding surface has been selected and after that, equivalent control (EQ) rule has been applied without assuming non-linearity. Furthermore, switched control (SW) rule has been applied to reduce unknown non-linearity. Upper bound of this non-linearity can be estimated by adopting fuzzy based control. Selection of sliding surface with application of control rules to ensure the trajectory area and remain on this. Mathematical equations governing selection of integral sliding area becomes:

$$R(t) = \dot{U}_{AC}(t) - \int_0^t (\ddot{U}_{ACR}(t) - S_1 E(t) - S_2 \dot{E}(t)) dt \quad (19)$$

where, U_{ACR} is Reference grid voltage, Tracked error (E) = $U_{AC} - U_{ACR}$, S_1, S_2 is positive constants.

$$\dot{R} = \left(\begin{aligned} &-\frac{1}{R_{\text{Load}} C_{AC}} \dot{U}_{AC} - \frac{1}{L_{AC} C_{AC}} U_{AC} - \frac{1}{L_{AC} C_{AC}} U_{AC} \\ &+ \frac{(2D_T - 1)}{L_{AC} C_{AC}} U_{DC} + G - \ddot{U}_{ACR} + S_1 \dot{E} + S_2 E \end{aligned} \right) \quad (20)$$

Putting \dot{R} by neglecting G (non-linearity), the D_{EQ} (Equivalent controls) becomes,

$$D_{EQ} = 0.5 \left[1 + \frac{L_{AC} C_{AC}}{U_{DC}} \left(\begin{aligned} &\frac{1}{R_{\text{Load}} C_{AC}} \dot{U}_{AC} \\ &+ \frac{1}{L_{AC} C_{AC}} \\ &+ \ddot{U}_{ACR} - S_1 \dot{E} - S_2 E \end{aligned} \right) \right] \quad (21)$$

Nevertheless, Eqn. (21) has not been evaluated explicitly due to ignorance of non-linearity and proposed control rules become,

$$\left. \begin{aligned} D_T &= D_{EQ} + D_{SW} \\ D_{SW} &= -\frac{1}{2} \left(\frac{L_{AC} C_{AC}}{U_{DC}} \right) G_E \text{sgn}(R) \end{aligned} \right\} \quad (22)$$

where, $|G| < G_E$ and G_E is higher limit of non-linearity of the system, practically, the upper limit of non-linearity cannot

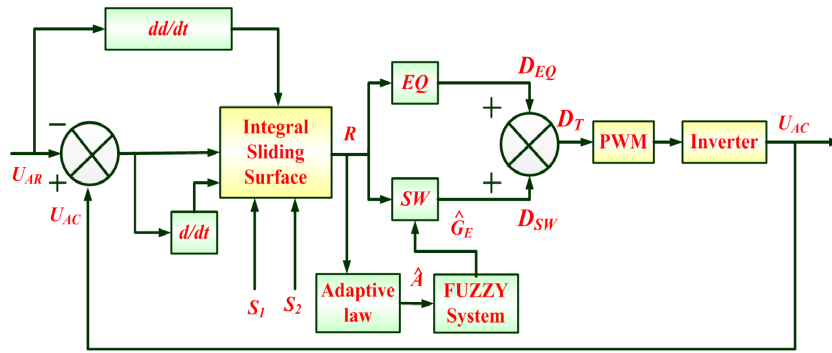

FIGURE 6. Proposed adaptive fuzzy sliding mode control.

be estimated. Therefore, an adaptive fuzzy based approach has been proposed to settle non-linearity. Selecting tracked error (E) as a fuzzy input with output of upper limit of uncertainties. Required fuzzy inference rule base becomes,

IF E is F_E^I , THEN G_E is A_I .

Where, $F_E^I = (I = 1, 2, 3, \dots, n)$, $A_I (I = 1, 2, 3, \dots, n)$, and n is Fuzzy rules number's input/output fuzzy set. Centroid method is employed to estimate defuzzification output as,

$$G_E = \frac{\sum W_I * A_I}{\sum W_I} = A^T \varepsilon / F \quad (23)$$

A_I is adjusting value vector, ε / F is fuzzy vector function,

$$\varepsilon / F_I = \frac{W_I}{\sum W_I}, \quad I = 1, 2, \dots, n \quad (24)$$

Using universal approximation theory, mathematical relations can be expressed for optimal parametric satisfaction as,

$$G_E^* = G_E + \varepsilon = A^* T \varepsilon / F \quad (25)$$

where, ε is Approx. error = $|\varepsilon| < E_P$, E_P is positive constant, fuzzy based system is proposed to compensate upper limit of non-linearity and G_E is redesigned as,

$$\hat{G}_E = \hat{A}^T \varepsilon / F \quad (26)$$

where, $\hat{A} = A^*$ estimator, replacing G_E from (22) using \hat{G}_E and putting in equation (21) and (22), final controlling law is expressed mathematically as,

$$D_T = \frac{1}{2} \left[1 + \frac{L_{AC} C_{AC}}{U_{DC}} \begin{pmatrix} \frac{1}{R_{Load} C_{AC}} \ddot{U}_{AC} \\ + \frac{1}{L_{AC} C_{AC}} U_{AC} \\ + \ddot{U}_{ACR} - S_1 \dot{E} - S_2 E \end{pmatrix} \right] \quad (27)$$

Putting equation (27) in (20), we get

$$\dot{R} = G - \hat{G}_E \text{sgn}(R), \quad \tilde{A} = \hat{A} - A^* \quad (28)$$

In this research work, fuzzy logic control is combined with sliding mode controller which works as hybrid control for generation of gating pulses of inverter and adaptive rules based Lyapunov stability controller has been proposed which

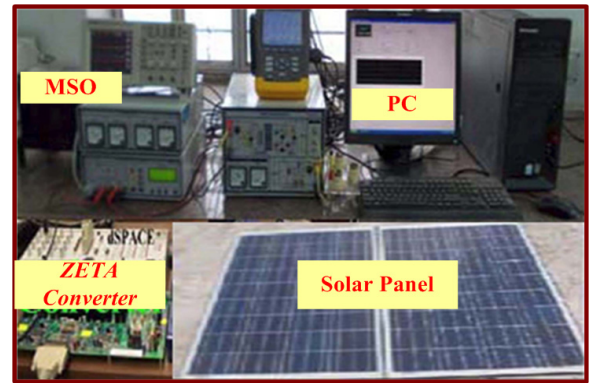

FIGURE 7. Proposed PV based laboratory setup.

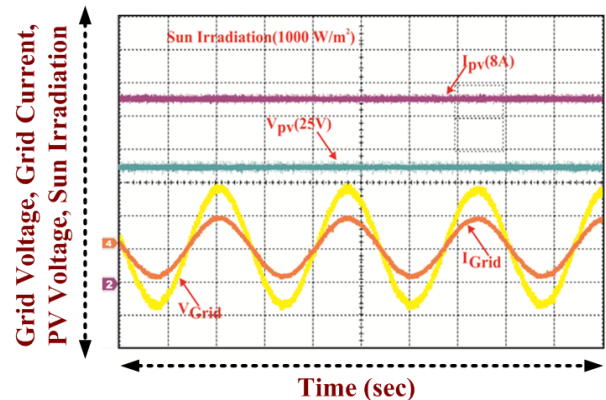

FIGURE 8. Experimental steady state PV responses with grid.

ensure PV power tracking stability and expressed mathematically as,

$$\text{Lyapunov stability } (V_L) = 0.5R^2 + \frac{1}{2\eta_p} \tilde{A}^T \tilde{A} \quad (29)$$

where, η_p is the positive constant,

$$\left. \begin{aligned} & \dot{V}_L R \dot{R} + \frac{1}{\eta_p} \tilde{A}^T \dot{\tilde{A}} \\ & = R \left[G - \tilde{G}_E \text{sgn}(R) \right] + \frac{1}{\eta_p} \tilde{A}^T \dot{\tilde{A}} \\ & = R \left[G - \hat{A}^T \varepsilon / F \text{sgn}(R) \right] + \frac{1}{\eta_p} (\tilde{A} - A^*)^T \dot{\tilde{A}} \\ & = R G - \hat{A}^T \varepsilon / F |R| + \frac{1}{\eta_p} (\tilde{A} - A^*)^T \dot{\tilde{A}} \end{aligned} \right\} \quad (30)$$

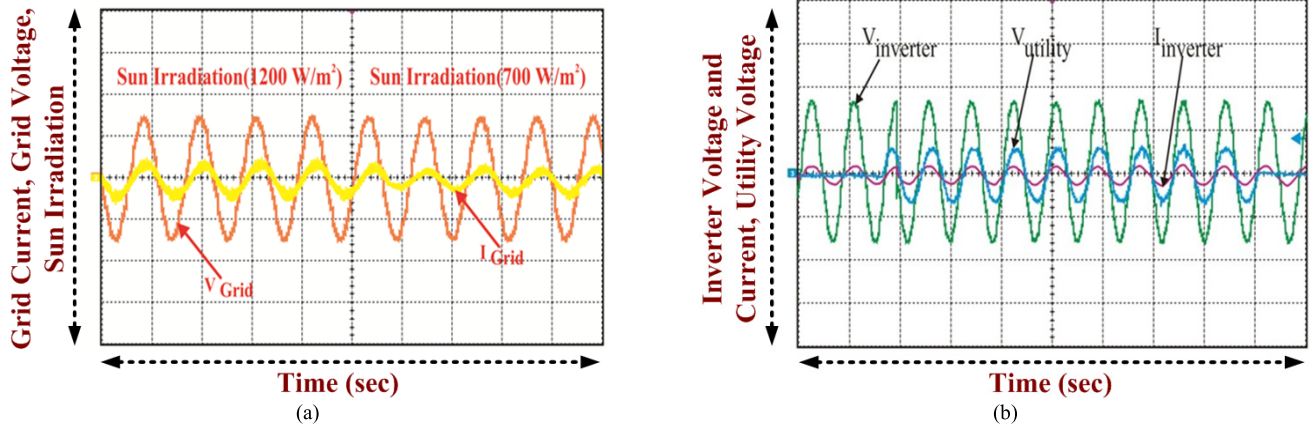

FIGURE 9. Experimental results (a)Grid voltage/current with unit power factor achievement under varying insolation level, (b)Inverter voltage, current and grid voltage.

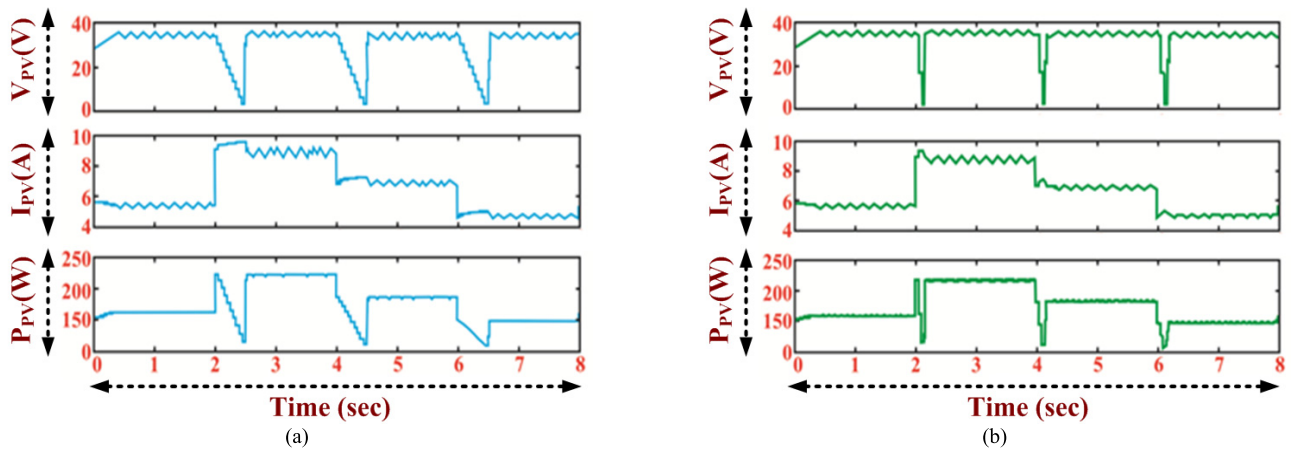

FIGURE 10. Tracking performance (a) P&O method, (b) Proposed concept.

For $V_L \leq 0$, Eqn. (30) becomes,

$$\dot{\hat{A}} = \dot{A} = \eta_p |R|^\varepsilon / F \quad (31)$$

Combining Eqn. (30) and (31)

$$t \rightarrow \infty \quad (32)$$

Here, \dot{V}_L becomes negative and as per Lyapunov stability criteria, system becomes asymptotically stable. Additionally, it may reveal that $V_L \rightarrow 0$ as $t \rightarrow \infty$ tracked error ($E \rightarrow 0$). Also, as $t \rightarrow \infty$, inverter output is able to track grid reference voltage with zero steady state error.

IV. HARDWARE SET-UP AND RESULTS DISCUSSIONS

The proposed sine-cosine based MPPT for PV integrated system has been implemented using dSPACE real time board. During hardware design LA-25P (Hall sensors) IRFP460 (MOSFET), MUR1520 (Fast recovery diode), IC SN74HC73AP (Buffer integrated circuit) and HCPL-3120 (Driver integrated circuit) have been employed as major components. The Simulink model is interfaced with hardware

circuitry using dSPACE control board, which is completely programmable. The dSPACE real time board comprises 36 Analog to Digital (ADC) and 8 Digital to Analog (DAC) channels. Control desk is employed to monitor sensed (V_{PV} , I_{PV}) signals which are passed through analog grid integrated system and laboratory set-up has shown in Fig 7.

Fig. 8 depicts the PV voltage, current and grid voltage/current under sun insolation level 1000 W/m^2 . The experimental response demonstrates the unity power factor achievement using proposed MPPT and inverter controller with dSPACE platform. Fig. 9(a) demonstrates the grid voltage/current with unit power factor achievement under varying insolation level.

Fig. 9(b) shows the inverter voltage, current and grid voltage obtained practically by employment of proposed inverter controller. Experimental response reveals that inverter voltage and utility grid voltage are synchronized to each other.

The performance of proposed MPPT algorithms versus P&O method under start-up operation has been evaluated and depicted in Fig. 10(a)-(b). It reveals that the proposed MPPT methodology achieved rapid MPP under dynamic

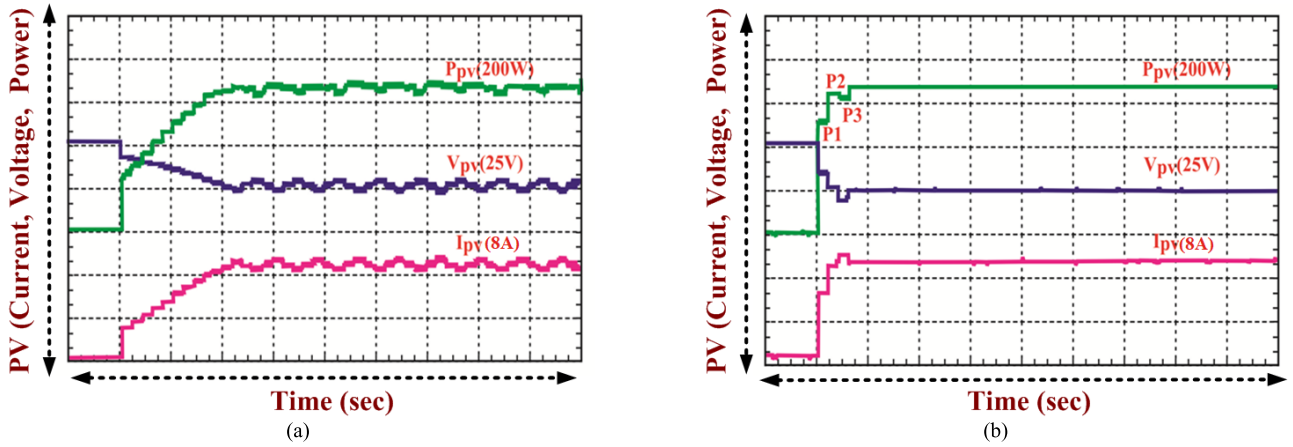

FIGURE 11. Startup behavior (a) conventional P&O (b) proposed MSCO based MPPT.

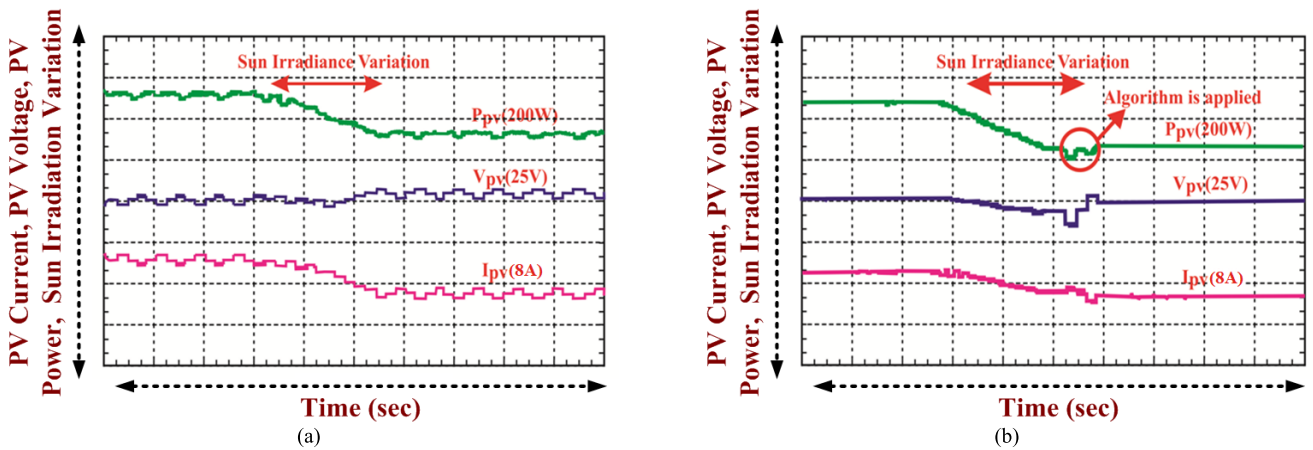

FIGURE 12. Experimental results under varying sun insolation level (a) P&O method, (b) Proposed concept.

weather conditions. Because of optimized parameters selection, the sine-cosine based MPPT has accurate MPP while P&O MPPT algorithm has more oscillations around MPP. Due to fixed MPP operation, the losses by means of artificial oscillation have been removed with improved efficiency under varying solar insolation. The performance of proposed sine-cosine algorithms has been compared with P&O method.

Fig. 10(a) explains the tracking performance of the classical P&O method when solar insolation level varies from 500 to 1000 W/m². It reveals that under this transient operation at t=2 to t=2.5 sec, the significant power drop takes place which results MPPT operation with considerable power losses. However, the accurate MPP tracking has been achieved with the application of proposed sine-cosine based MPPT algorithm provides very less power losses with precise and accurate PV tracking ability.

The startup behavior of the proposed PV system has been evaluated and depicted using Fig. 11(a) and Fig. 11(b) with conventional P&O and proposed MSCO based MPPT methods, respectively. The MSCO based employed MPPT has fast MPP achievement period, accurate performance and

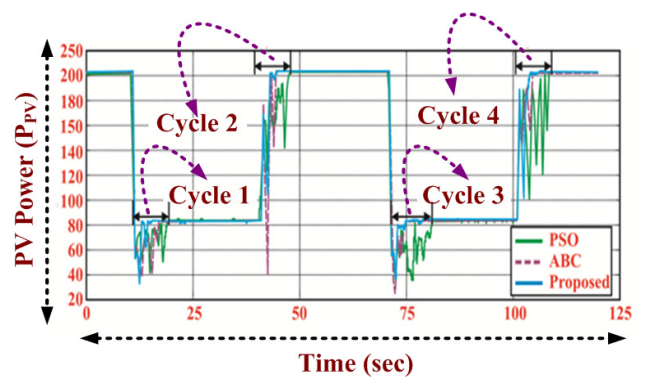

FIGURE 13. Comparison of PSO, ABC and proposed MSCO based MPPT.

zero oscillations nearer to MPP region and hence high PV tracking efficiency because the losses due to oscillations have been neglected. Under varying sun insolation level, the performance of the proposed versus classical P&O MPPT methods have also been validated using practical responses

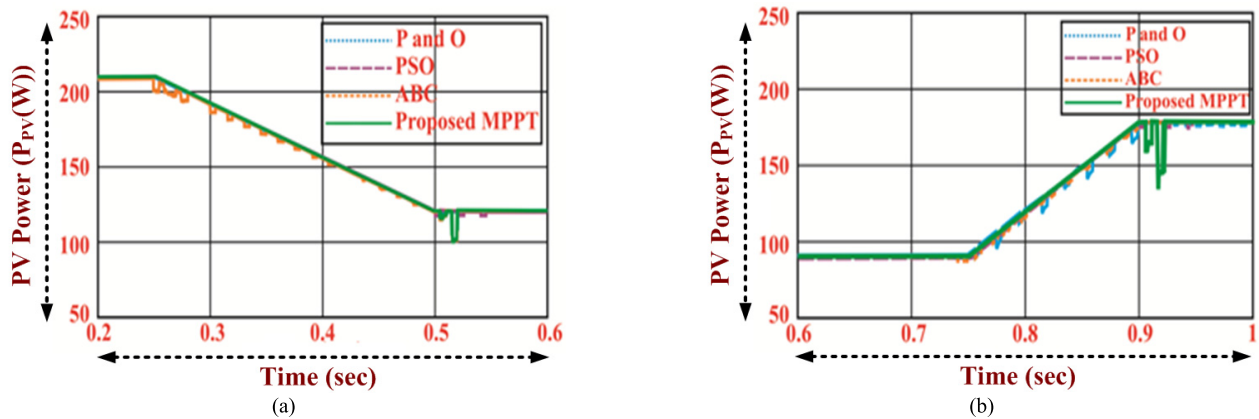

FIGURE 14. Performance of the proposed PV system under (a) decreasing solar insolation conditions, (b) increasing solar insolation conditions.

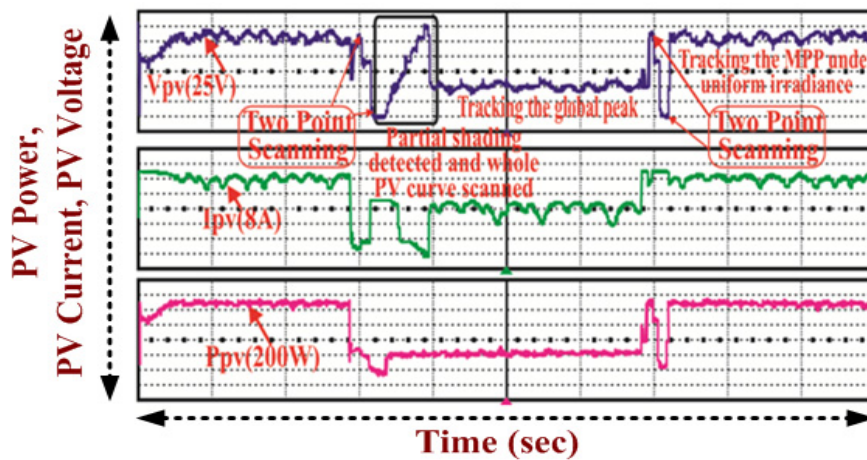

FIGURE 15. Performance of the proposed MSCO based MPPT for PV system under uniform and partial shade conditions.

in Fig. 12(a) and Fig. 12(b), respectively. Experimental responses reveal that the proposed sine-cosine algorithm detects variation in environmental condition and detain next assessment up until the transition is dissolved. The working of the proposed MPPT method has been evaluated by comparing existing PSO and ABC MPPT techniques under same operating conditions. The comparison of PSO, ABC and proposed MSCO based MPPT has been presented by Fig. 13, which reveals that PV power extraction using MSCO method, has rapid tracking speed, fast convergence to achieve MPP with zero oscillations around this operating point.

TABLE 2. Tracking efficiency/tracking efficiency (average).

Methods	Cycles				
	I	II	III	IV	Average
PSO	96.32	93.67	96.21	92.32	94.63
ABC	98.27	94.37	98.55	97.39	97.13
MSCO (Proposed)	99.67	97.49	98.84	97.54	98.40

Table 2 presents the PV tracking efficiency by employment of PSO, ABC, and MSCO MPPT methods; which demonstrates MSCO has better PV tracked efficiency

compared to PSO and ABC algorithms. Practical tracking efficiency presented in Table 2 strongly supports the ability of the MSCO based MPPT algorithm under fluctuating weather conditions compared to PSO and ABC based MPPT methods. The performance of the proposed PV power system has been tested under decreasing and increasing solar insolation conditions using obtained practical results and respectively shown in Fig. 14(a)-(b).

Practical responses reveal that the proposed MPPT controller works accurately with high PV tracking efficiency and consisting fast convergence speed under decreasing and increasing solar irradiance profile. Fig. 15 explains the performance of the proposed MSCO based MPPT for PV system under uniform and partial shade conditions. Practical responses reveal that the global power point is achieved under partial shading condition and MPPT controller is able to differentiate uniform and shaded situations accurately.

V. CONCLUSION

An improved sine-cosine optimized algorithm proposed and realized using dSPACE platform in the paper work.

Complete hardware testing condition performed under uniform and non-uniform weather conditions for PV grid integration, and results compared with to recent PSO and ABC based algorithms. Obtained results confirms that the developed MSCO algorithm provides simple implementation strategy, better tracking ability, high convergence rate and execute in digital controller platform using dSPACE. The MPPT operation maintained under different perturbation conditions by selecting optimal duty ratio of ZETA DC-DC converter. The employed inverter controller provides the unity power factor regulated by synchronizing utility grid through the inverter. Complete set of experimental results validates the theoretical background developed and proposed algorithm suitable for real time renewable energy enrichment in industrial and domestic sectors.

REFERENCES

- [1] J. R. R. Zientarski, M. L. da Silva Martins, J. R. Pinheiro, and H. L. Hey, "Series-connected partial-power converters applied to PV systems: A design approach based on step-up/down voltage regulation range," *IEEE Trans. Power Electron.*, vol. 33, no. 9, pp. 7622–7633, Sep. 2018.
- [2] B. Singh, C. Jain, and A. Bansal, "An improved adjustable step adaptive neuron-based control approach for the grid-supportive SPV system," *IEEE Trans. Ind. Appl.*, vol. 54, no. 1, pp. 563–570, Jan./Feb. 2018.
- [3] P. Sanjeevikumar, G. Grandi, P. W. Wheeler, F. Blaabjerg, and J. Loncarski, "A simple MPPT algorithm for novel PV power generation system by high output voltage DC-DC boost converter," in *Proc. IEEE 24th Int. Symp. Ind. Electron. (ISIE)*, Buzios, Brazil, Jun. 2015, pp. 214–220.
- [4] A. M. Noman, K. E. Addoweesh, and H. M. Mashaly, "Simulation and dSPACE hardware implementation of the MPPT techniques using buck boost converter," in *Proc. IEEE 27th Can. Conf. Elect. Comput. Eng. (CCECE)*, Toronto, ON, Canada, May 2014, pp. 1–8.
- [5] O. Khan, S. Acharya, M. Al Hosani, and M. S. El Moursi, "Hill climbing power flow algorithm for hybrid DC/AC microgrids," *IEEE Trans. Power Electron.*, vol. 33, no. 7, pp. 5532–5537, Jul. 2018.
- [6] D. C. Huynh and M. W. Dunnigan, "Development and comparison of an improved incremental conductance algorithm for tracking the MPP of a solar PV panel," *IEEE Trans. Sustain. Energy*, vol. 7, no. 4, pp. 1421–1429, Oct. 2016.
- [7] Z. Subiyanto, A. Ghani, A. Mohamed, and M. A. Hannan, "Prototype development of an intelligent power conditioning unit for PV generation system," in *Proc. IEEE Int. Conf. Ind. Technol. (ICIT)*, Cape Town, South Africa, Feb. 2013, pp. 758–763.
- [8] A. G. Al-Gizzi, A. Craciunescu, and S. J. Al-Chalhawi, "The use of ANN to supervise the PV MPPT based on FLC," in *Proc. 10th Int. Symp. Adv. Topics Elect. Eng. (ATEE)*, Bucharest, Romania, Mar. 2017, pp. 703–708.
- [9] R. B. A. Koad, A. F. Zobia, and A. El-Shahat, "A novel MPPT algorithm based on particle swarm optimization for photovoltaic systems," *IEEE Trans. Sustain. Energy*, vol. 8, no. 2, pp. 468–476, Apr. 2017.
- [10] N. Priyadarshi, S. Padmanaban, P. K. Maroti, and A. Sharma, "An extensive practical investigation of FPSO-based MPPT for grid integrated PV system under variable operating conditions with anti-islanding protection," *IEEE Syst. J.*, to be published. [Online]. Available: <https://ieeexplore.ieee.org/document/8333784>
- [11] K. Sundareswaran, P. Sankar, P. S. R. Nayak, S. P. Simon, and S. Palani, "Enhanced energy output from a PV system under partial shaded conditions through artificial bee colony," *IEEE Trans. Sustain. Energy*, vol. 6, no. 1, pp. 198–209, Jul. 2015.
- [12] K. Sundareswaran, V. Vigneshkumar, P. Sankar, S. P. Simon, P. S. R. Nayak, and S. Palani, "Development of an improved P&O algorithm assisted through a colony of foraging ants for MPPT in PV system," *IEEE Trans. Ind. Informat.*, vol. 12, no. 1, pp. 187–200, Feb. 2016.
- [13] C. Huang, L. Wang, R. S.-C. Yeung, Z. Zhang, H. S.-H. Chung, and A. Bensoussan, "A prediction model-guided Jaya algorithm for the PV system maximum power point tracking," *IEEE Trans. Sustain. Energy*, vol. 9, no. 1, pp. 45–55, Jan. 2018.
- [14] S. Mohanty, B. Subudhi, and P. K. Ray, "A new MPPT design using grey wolf optimization technique for photovoltaic system under partial shading conditions," *IEEE Trans. Sustain. Energy*, vol. 7, no. 1, pp. 181–188, Jan. 2016.
- [15] A. Lashab, D. Sera, J. M. Guerrero, L. Mathe, and A. Bouzid, "Discrete model-predictive-control-based maximum power point tracking for PV systems: Overview and evaluation," *IEEE Trans. Power Electron.*, vol. 33, no. 8, pp. 7273–7287, Aug. 2018.
- [16] E. A. R. E. Ariff, O. Dordevic, and M. Jones, "A space vector PWM technique for a three-level symmetrical six-phase drive," *IEEE Trans. Ind. Electron.*, vol. 64, no. 11, pp. 8396–8405, Nov. 2017.
- [17] P. K.-H. Dost and C. Sourkounis, "Flexible dimensioning opportunities of a (virtual) flux-based hysteresis controller for a reduced switching frequency," *IEEE Trans. Ind. Appl.*, vol. 52, no. 4, pp. 3451–3460, Jul./Aug. 2016.
- [18] Q. Zeng and L. Chang, "An advanced SVPWM-based predictive current controller for three-phase inverters in distributed generation systems," *IEEE Trans. Ind. Electron.*, vol. 55, no. 3, pp. 1235–1246, Mar. 2008.
- [19] N. Priyadarshi, S. Padmanaban, M. S. Bhaskar, F. Blaabjerg, and A. Sharma, "Fuzzy SVPWM-based inverter control realisation of grid integrated photovoltaic-wind system with fuzzy particle swarm optimisation maximum power point tracking algorithm for a grid-connected PV/wind power generation system: Hardware implementation," *IET Electr. Power Appl.*, vol. 12, no. 7, pp. 962–971, Apr. 2018.
- [20] R. Kumar and B. Singh, "BLDC motor driven solar PV array fed water pumping system employing zeta converter," *IEEE Trans. Ind. Appl.*, vol. 52, no. 3, pp. 2315–2322, May 2016.
- [21] A. El Khateb, N. A. Rahim, J. Selvaraj, and M. N. Uddin, "Fuzzy-logic-controller-based SEPIC converter for maximum power point tracking," *IEEE Trans. Ind. Appl.*, vol. 50, no. 4, pp. 2349–2358, Jul./Aug. 2014.
- [22] N. Kumar, I. Hussain, B. Singh, and B. K. Panigrahi, "Single sensor-based MPPT of partially shaded PV system for battery charging by using cauchy and Gaussian sine cosine optimization," *IEEE Trans. Energy Convers.*, vol. 32, no. 3, pp. 983–992, Sep. 2017.
- [23] N. Sahu and N. D. Londhe, "Optimization based selective harmonic elimination in multi-level inverters," in *Proc. Nat. Power Electron. Conf. (NPEC)*, Pune, India, Dec. 2017, pp. 325–329.
- [24] N. Kumar, I. Hussain, B. Singh, and B. K. Panigrahi, "MPPT in dynamic condition of partially shaded PV system by using WODE technique," *IEEE Trans. Sustain. Energy*, vol. 8, no. 3, pp. 1204–1214, Jul. 2017.
- [25] C. Qu, Z. Zeng, J. Dai, Z. Yi, and W. He, "A modified sine-cosine algorithm based on neighborhood search and greedy levy mutation," *Comput. Intell. Neurosci.*, vol. 2018, Jul. 2018, Art. no. 4231647.



SANJEEVIKUMAR PADMANABAN (M'12–SM'15) received the bachelor's degree from the University of Madras, India, in 2002, the master's degree (Hons.) from Pondicherry University, India, in 2006, and the Ph.D. degree from the University of Bologna, Italy, in 2012. He was an Associate Professor with VIT University, from 2012 to 2013. In 2013, he joined the National Institute of Technology (Puducherry), India, as a Faculty Member. In 2014, he was invited as a

Visiting Researcher with Qatar University, Qatar, funded by the Qatar National Research Foundation (Government of Qatar) and was also a Lead Researcher with the Dublin Institute of Technology, Ireland. He was an Associate Professor with the Department of Electrical and Electronics Engineering, University of Johannesburg, South Africa, from 2016 to 2018. Since 2018, he has been a Faculty Member with the Department of Energy Technology, Aalborg University, Esbjerg, Denmark. He has authored over 300 scientific papers and has received the Best Paper cum Most Excellence Research Paper Award from IET-SEICON'13 and IET-CEAT'16 and five best paper awards from ETAERE'16 sponsored Lecture Note in Electrical Engineering, Springer book series. He is a Senior Member of the IEEE, is a Fellow Institute of Electronics and Telecommunication Engineers, India, and is a Fellow Institute of Engineers, India. He has involved as a member on invitation in various capacities in the committees for several international conferences, including the IEEE and the IET. He serves as an Editor/Associate Editor/or in the Editorial Board of many-refereed journals, in particular, the IEEE SYSTEMS JOURNAL, the IEEE ACCESS, and the *IET Power Electronics*, and serves as a Subject Editor for *IET Renewable Power Generation* and the *IET Generation, Transmission and Distribution*.



NEERAJ PRIYADARSHI received the M.Tech. degree in power electronics and drives from the Vellore Institute of Technology, Vellore, India, in 2010, and the Ph.D. degree from the Government College of Technology and Engineering, Udaipur, India. He was with JK University, Geetanjali Institute, Global Institute, and SS Group, Rajasthan, India. He is currently with the Department of Electrical Engineering, Birsa Institute of Technology (Trust), Ranchi, India. He has published over 40 papers in journals and conferences. His current research interests include power electronics, control systems, power quality, and solar power generation. He is a Reviewer of the IEEE SYSTEM JOURNAL, the *International Journal of Modeling and Simulation*, and the *International Journal of Renewable Energy Research*.



FAROOQUE AZAM received the bachelor's degree in computer science and engineering from Visvesvaraya Technological University, India, in 2011, and the master's degree in computer science and engineering from Jawaharlal Nehru Technological University, India, in 2013. He is currently with the School of Computing and Information Technology, REVA University, Bengaluru, India. He has authored scientific papers in international journals. His research interest includes the design and realization of optimization algorithms in various applications, such as renewable energy.



JENS BO HOLM-NIELSEN is currently with the Department of Energy Technology, Aalborg University, and is the Head of the Esbjerg Energy Section. On this research, his activities established the Center for Bioenergy and Green Engineering, in 2009, and he serves as the Head of the research group. He has vast experience in the field of biorefinery concepts and biogas production—anaerobic digestion, implementation projects of bio-energy systems in Denmark with provinces and European states. He has served as a Technical Advisory for many industries in this field. He has executed many large-scale European Union and United Nation projects in research aspects of bioenergy, bio refinery processes, the full chain of biogas, and green engineering. He has authored over 100 scientific papers. He was a member on invitation in various capacities in the committees of over 200 various international conferences and was an Organizer of international conferences, workshops, and training programmes in Europe, Central Asia, and China. His focus areas are renewable energy, sustainability, and green jobs for all.



AMARJEET KUMAR SHARMA received the B.E. degree in electrical engineering from the Muzaffarpur Institute of Technology, Muzaffarpur, in 2010, and the M.Tech. degree in electrical engineering (power system) from the Maulana Abul Kalam Azad University of Technology, West Bengal, in 2016. He is currently with the Department of Electrical Engineering, Birsa Institute of Technology (Trust), Ranchi, India. He has published various papers in international journals and attended workshop/conferences on renewable energy and modern trends in electrical power systems. His research interests include renewable energy and electrical machine.



MAHAJAN SAGAR BHASKAR (M'15) received the bachelor's degree in electronics and telecommunication engineering from the University of Mumbai, Mumbai, India, in 2011, and the master's degree in power electronics and drives from the Vellore Institute of Technology, India, in 2014. He submitted his Ph.D. thesis with the Department of Electrical and Electronic Engineering Science, University of Johannesburg, South Africa. He was as an Assistant Professor and was a Research Coordinator with the Department of Electrical and Electronics Engineering, Marathwada Institute of Technology, Aurangabad, India. He is currently a Visiting Researcher with the Department of Electrical Engineering, Qatar University, Doha, Qatar. He has published scientific papers in the field of power electronics, with particular reference to XY converter family, multi-level dc/dc and dc/ac converter, and high-gain converter. He has authored over 100 scientific papers. He is a member of the IEEE, the IEEE Industrial Electronics Society, Power Electronics Society, Industrial Application Society, and the Power and Energy Society. He received the Best Paper cum Most Excellence Research Paper Award from IEEE-ICCPCT'14 and IET-CEAT'16 and Best Paper Awards from ETAERE'16 sponsored Lecture Note in Electrical Engineering, Springer book series. He is a Reviewer Member of various international journals and conferences, including the IEEE and IET.



EKLAS HOSSAIN (M'09–SM'17) received the B.S. degree in electrical and electronic engineering from the Khulna University of Engineering and Technology, Bangladesh, in 2006, the M.S. degree in mechatronics and robotics from the International Islamic University of Malaysia, Malaysia, in 2010, and the Ph.D. degree from the College of Engineering and Applied Science, University of Wisconsin–Milwaukee. He has been working in the area of distributed power systems and renewable energy integration for the last 10 years, and has published a number of research papers and posters in this field. Since 2015, he has been an Assistant Professor with the Department of Electrical Engineering and Renewable Energy, Oregon Tech, where is currently involved with several research projects on renewable energy and grid tied microgrid systems. His research interests include the modeling, analysis, design, and control of power electronic devices; energy storage systems; renewable energy sources; integration of distributed generation systems; microgrid and smart grid applications; robotics; and advanced control systems. He, with his dedicated research team, is looking forward to explore methods to make the electric power systems more sustainable, cost-effective, and secure through extensive research and analysis on energy storage, microgrid systems, and renewable energy sources. He is also a registered Professional Engineer in the state of Oregon, USA. He is currently serving as an Associate Editor for the IEEE ACCESS.

...