

Received August 28, 2018, accepted September 25, 2018, date of publication October 22, 2018, date of current version November 19, 2018.

Digital Object Identifier 10.1109/ACCESS.2018.2877354

# Efficiency and Reliability Analyses of AC and 380 V DC Distribution in Data Centers

**BIJEN R. SHRESTHA<sup>1</sup>, UJJWOL TAMRAKAR<sup>2</sup>, (Student Member, IEEE),  
TIMOTHY M. HANSEN<sup>1b2</sup>, (Member, IEEE),  
BISHNU P. BHATTARAI<sup>3</sup>, (Senior Member, IEEE), SEAN JAMES<sup>4</sup>,  
AND REINALDO TONKOSKI<sup>1b2</sup>, (Senior Member, IEEE)**

<sup>1</sup>Amazon AWS, Herndon, VA 20171, USA

<sup>2</sup>Department of Electrical Engineering and Computer Science, South Dakota State University, Brookings, SD 57007, USA

<sup>3</sup>Pacific Northwest National Laboratory, Richland, WA 99352, USA

<sup>4</sup>Microsoft Inc., Redmond, WA 98052, USA

Corresponding author: Reinaldo Tonkoski (tonkoski@ieee.org)

This work was supported in part by Microsoft Inc., in part by the South Dakota Board of Regents, and in part by the National Science Foundation (NSF) under Grant ECCS-1608722.

**ABSTRACT** Modern data centers consume large amounts of electricity, resulting in high operational costs. The efficiency of a data center power distribution system can be increased and the operational cost reduced if the number of power conversion stages can be minimized and more efficient converters, such as wide bandgap converters, are used. This can be achieved by using dc distribution voltage at the rack level by eliminating extra conversion stages. In this paper, benchmarks for both ac and 380-V dc data centers were developed and efficiency analyses were performed for an entire year. The impact of integrating photovoltaic (PV) systems into the data centers has also been analyzed in both cases in terms of efficiency. The results show that 380-V dc data centers are more efficient than ac data centers with and without PV integration. Furthermore, the reliability of an ac system was compared with a 380-V dc architecture with Tier-IV standard. Monte-Carlo simulations were used to perform reliability analyses for different levels of redundancy in the uninterruptible power supply system for both cases. The simulation results showed that the 380-V dc distribution system had a higher level of reliability than the ac distribution system in data centers.

**INDEX TERMS** Data center, efficiency, reliability, renewable integration.

## ACRONYMS

GaN	Gallium Nitride
GHI	Global Horizontal Irradiance.
GTI	Global Tilted Irradiance.
MTBF	Mean Time Between Failure.
MTBM	Mean Time Between Maintenance.
MTTR	Mean Time To Repair.
PDU	Power Distribution Unit.
PSU	Power Supply Unit.
PUE	Power Usage Effectiveness.
PV	Photovoltaic.
RBD	Reliability Block Diagram.
SiC	Silicon Carbide.
TBF	Time Between Failure.
TTR	Time To Repair.
UPS	Uninterruptible Power Supply
VR	Voltage Regulator.
WBG	Wide Bandgap.

## I. INTRODUCTION

The energy consumption of data centers has been rapidly increasing. Major sectors of the economy, such as banking services in the financial industry, online sales services like Amazon, and social media such as Facebook, present massive energy demands. The servers and secondary support infrastructure required to run these data centers consume significant amounts of energy. Data centers will consume about 8% of the total world's energy by 2020 and emit 340 metric megatons of CO<sub>2</sub> annually [1]. Because of the increasing energy demand, data centers require efficient and reliable power distribution infrastructure. The efficiency of the power distribution system is to account for the increase in the operational costs and adverse environmental impact in terms of the data centers' carbon footprint. Moreover the increasing dependence on Internet-based services means data center's availability and reliability needs to be improved at the same-time. Maintaining high availability of electrical power

at all times is required to reduce the downtime of server racks and mitigate data loss. Interruption in data center's power delivery system can be very expensive to recover from, and the cost can easily escalate to millions of dollars per hour [2].

In a typical data center, around half of the power is lost in power conversion, distribution and cooling, and the remaining half is delivered to the IT load, resulting in the power delivery efficiency of below 50% [3]. The reasons for low data center efficiency is due to many cascaded power conversion stages and low efficiency of each converter. Furthermore, all power dissipation is basically heat which requires additional power to run cooling systems, further reducing the overall efficiency. The cost effectiveness of data centers depends on using highly efficient power conversion stages to reduce overall power consumption. The use of alternative energy sources such as solar, wind, stand-by diesel, and natural gas generators, can increase the power availability in a data center. Additionally, using redundant power distribution paths ensures increased power availability to dual-corded IT equipment. Components having high reliability would improve the overall reliability of a data center. Also, the power distribution path should have the least number of converters with high reliability. To evaluate various data center facilities with regard to their uptime, the Uptime Institute created the standard Tier classification system [4]. The Tiers (I to IV) are progressive, with each higher level tier placing additional requirements to enhance the uptime of data centers.

A data center's critical load comprises of IT equipment such as servers, switches and storage devices that are typically DC-based loads. The battery backup used in the uninterruptible power supply (UPS) systems, which are required during critical situations, are also based on DC. Hence, implementation of a DC distribution system instead of AC distribution system results in elimination of a number of conversion stages, thereby resulting in a more efficient distribution system [5]–[7]. The probability of electric power supply failure for IT equipment is reduced with fewer number of series connected power converters in the power distribution path. Findings shows that the converters used in DC data centers have low failure rates, hence, high availability [8], [9]. This paper analyses the efficiency and reliability of a 380 V DC distribution of data centers and compares it against a more traditional AC distribution. As the efficiency of data center varies largely depending upon the IT load, loss models for various data center components are developed taking into account the IT load variability. Moreover, recently a larger number of data centers have been planning to operate their cloud-scale data centers with renewable energy integration [10]–[12]. The effect of integrating PV in data centers on the efficiency has thus been analyzed. The advent of wide bandgap (WBG) based semiconductor devices such as silicon carbide (SiC) and gallium nitride (GaN) promises higher efficiencies and reliability in power converter units of the data centers [13], [14]. In this regard, the comparative study of efficiency and reliability of the 380 V DC system with WBG

devices is also performed. The contributions of this paper are: a comparative reliability analysis and efficiency comparison of (i) AC and 380 V DC data centers with and without renewable energy integration, and (ii) with the utilization of WBG semiconductors on the power conversion units.

The paper is organized as follows: Section II describes the AC and DC distribution architectures for data centers. More details of the data center benchmark used for simulation studies in this paper are provided in Section III. In Section IV, the models for the loss and efficiency calculations within a data center are developed. The efficiency and reliability analysis results are presented in Section VI and VII respectively. Section VIII concludes the paper.

## II. POWER DISTRIBUTION ARCHITECTURE FOR DATA CENTERS

The widely used architecture for power distribution in data centers is the AC power distribution architecture shown in Fig. 1. The power path contains uninterruptible power supply (UPS), power distribution unit (PDU), power supply unit (PSU), and voltage regulator (VR). Fig. 2 shows the facility level DC power distribution architecture where the number of power conversion stages is two as opposed to five in conventional AC distribution architecture.

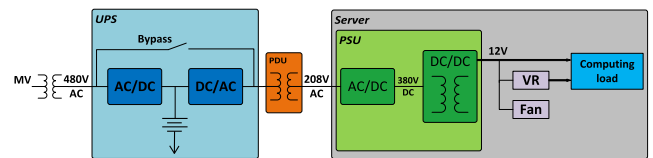

FIGURE 1. Conventional 480V AC power distribution architecture.

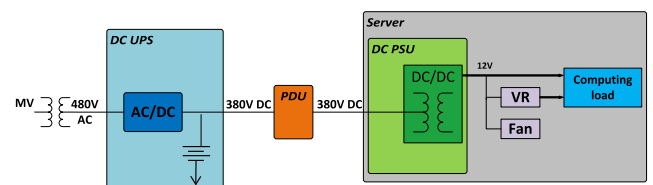

FIGURE 2. 380V DC power distribution architecture.

One of the most debated topics in modern data centers is which DC voltage level provides the most efficient and reliable power distribution. Few standards exist for DC voltage systems, such as the 12V standard in vehicles and 5V standard for serial bus devices. The most commonly used distribution system in the telecommunications network is based on 48V DC [15]. However, the power density of data centers is in the range of hundreds of megawatts as compared to telecommunication systems, which ranges from hundreds of kilowatts to a few megawatts only. Employing rack level 48V DC system in data centers distribution architecture would result in significant  $I^2R$  losses, making the system less efficient. This loss can be eliminated by increasing the cable size, however this

would require data centers to construct additional cable space and the increase in cost of copper cables could lead to large capital costs. Alternatively, the introduction of high voltage DC system in the data center's distribution system would reduce the  $I^2R$  losses. Additionally, in [16] it was shown that the volume of copper cable required in high voltage DC system is fifteen times smaller than 48V DC systems to transmit 100 kW of power. The studies show that 380V DC is an ideal voltage level considering the number of battery cells that are required to be connected for an energy storage system, availability of components with suitable ratings, and safety [3], [17]. Thus, a 380V DC distribution architecture will be used in this paper for comparative analysis with an AC distribution system.

### III. DATA CENTER BENCHMARK MODEL

The data center benchmark developed in [18] has been used to carry out the efficiency and reliability analyses in this paper. The benchmark consists of a 100 MW Tier-IV data center assumed to be located in Texas. The benchmark also consists of a 50 MW PV solar plant which is considered to be located in the vicinity of the data center premises. To study the effect of PV penetration on the data center efficiency, the analysis is performed for 30 MW and 50 MW PV installations. The wind generation is neglected to simplify the analysis. The data center has twenty-five 4 MW natural gas generators that make up a 100 MW backup source, and 192 MW-hr flooded lead acid battery storage system for 1 hour backup duration. The size of the battery storage system was calculated based on the peak IT load requirement.

The hourly global horizontal irradiance (GHI), in  $\text{kW}/\text{m}^2$ , was taken from Solar Anywhere website [19]. Homer Pro Micro-grid Analysis Tool was then used to resolve the GHI into its beam and diffuse radiation based on the clearness index [20]. GHI is then converted to global tilted irradiance (GTI), which is the solar irradiance incident on the panel surface [21]. A de-rating factor of 0.8 was considered for the calculations to account for the losses due to soiling, shading, snow cover, and aging [22]. The PV generation in the year 2011 for the 50 MW solar plant considered in this paper is shown in Fig. 3. Similarly, the data center load profile used in this work is based on the 100 kW NREL data center load in 2011 [23], which was scaled to 100 MW for this study.

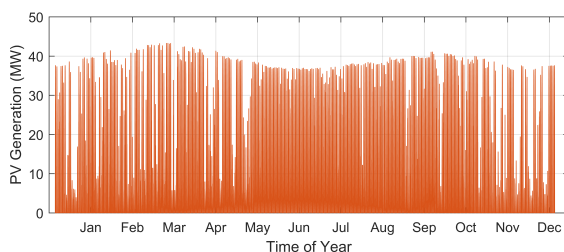

FIGURE 3. Hourly average solar power for 50MW installed capacity.

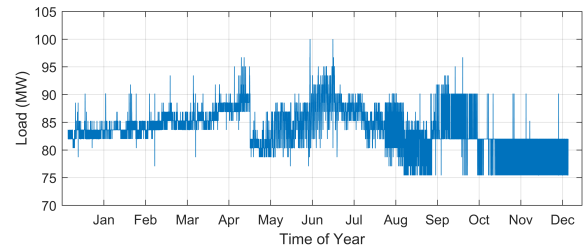

FIGURE 4. Hourly average data center load [23].

The hourly averaged load data used is shown in Fig. 4. The peak to average ratio is 1.20.

### A. SOLAR INTEGRATION IN DATA CENTER USING AC DISTRIBUTION SYSTEM

A single line diagram of Tier-IV AC power distribution system with 50 MW PV integration is shown in Fig. 5. To achieve solar plant capacity of 50 MW, fifty 1 MW solar plants are considered. In each of the 1 MW plant, 23 solar panels are connected in series to form a string to achieve 850 V DC to match the inverter DC input voltage. A total of 3125 solar panels are required to achieve the capacity of 1 MW. Hence, there will be 136 parallel solar panel strings. These parallel strings are connected to the DC input of 1 MW Satcon inverters. The inverter converts 850 V DC to three phase 12.47 kV AC with the integrated transformers. The output of all 50 inverters are connected to a common 12.47 kV AC bus. Two step down transformers located at the data center are used to connect to 480 V AC bus of the data center.

Twenty-five 4 MW systems feed 25 individual data rooms in the data center. Each 4 MW rated data room has dual power sources (PDU A and PDU B) as shown. Each of these sources will have two 1 MW UPSs connected in parallel. In the figure,  $n_1$  represents the number of N-load fed by source A,  $n_2$  represents the number of 2N-load fed by sources A and B, and  $n_3$  represents the number of N-load fed by source B in each data room.

### B. SOLAR INTEGRATION IN DATA CENTER USING 380V DC DISTRIBUTION SYSTEM

Fig. 6 shows the single line diagram of the Tier-IV DC power distribution architecture with 50 MW PV integration. The PV setup is similar to that used in AC powering option, but the step down transformer at the data center connects directly to the 380 V DC bus via a rectifier. The rectifier converts 12.8 kV AC voltage to 380 V DC voltage. The number of conversion stages before it's integrated in AC and 380V DC the data center power distribution systems is thus different.

### IV. COMPONENT LOSS MODEL AND EFFICIENCY MODEL

The simplistic empirical approach to estimate the data center's efficiency is to sum up the power consumption of all IT equipment and dividing by the total power input of the data center. This is known as the Power Usage

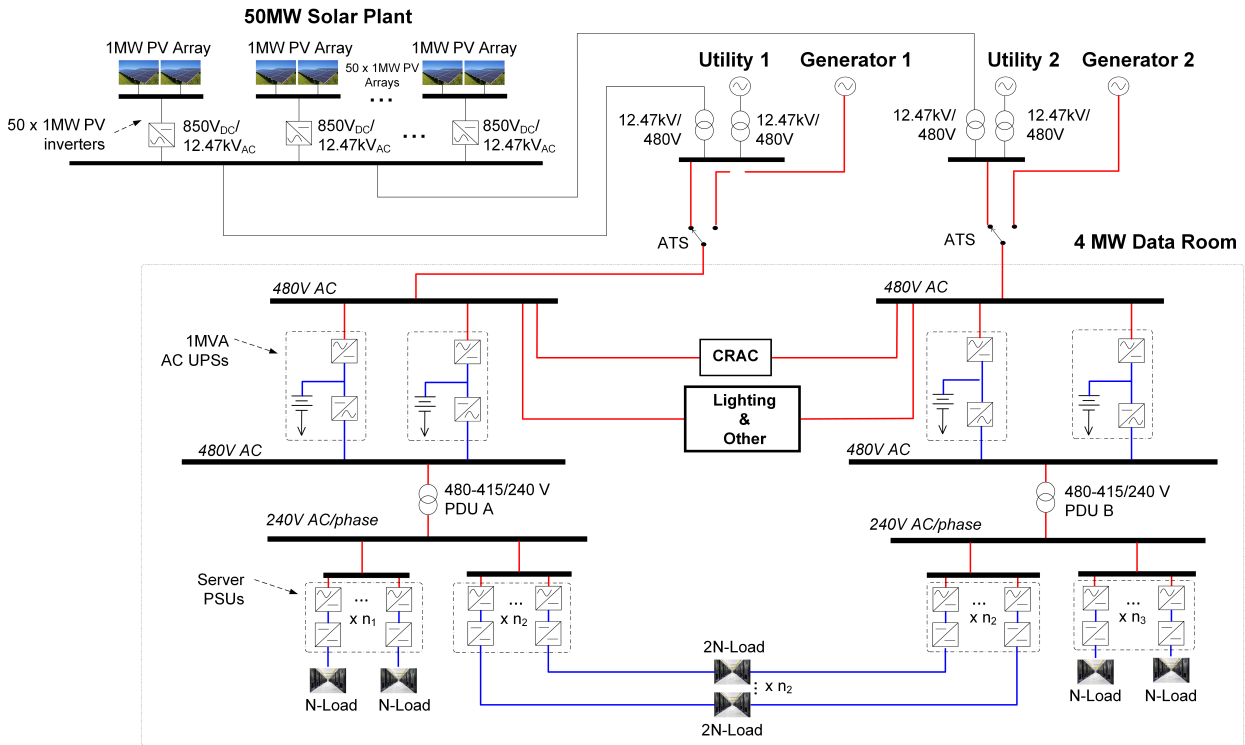

FIGURE 5. AC power distribution system with 50 MW PV integration.

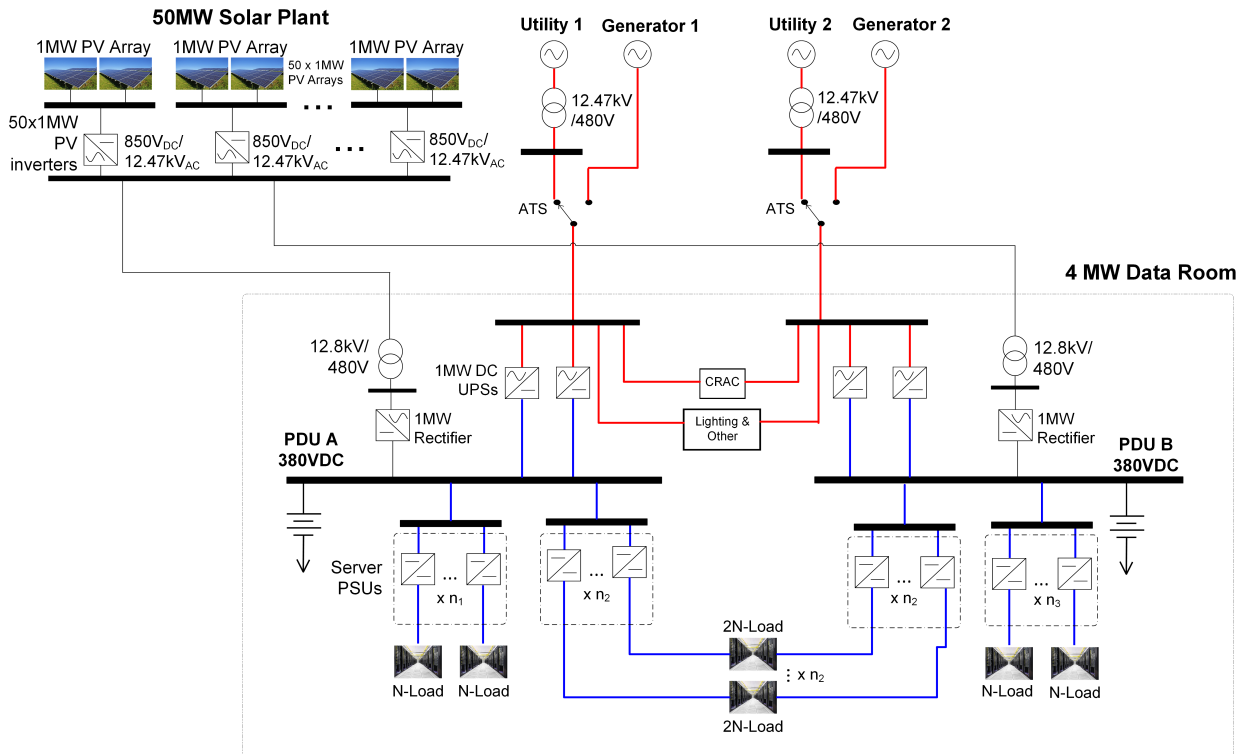

FIGURE 6. 380V DC power distribution system with 50 MW PV integration.

Effectiveness (PUE) of a data center and is a metric that represents how much power is consumed by the IT equipment, in contrast to power used by the cooling, lighting

and other additional equipment. However, such an approach uses rated efficiency of the components resulting in an imprecise estimate of data center's efficiency as the IT load

variations are not taken into consideration. The efficiency of the components vary to a large degree based on their loading. Moreover, the power and cooling equipment in data centers typically operates well below their rated design capacity. The converters are over-sized to provide safety margin and handle load diversity. The accuracy of the data center efficiency estimation thus depends on the accuracy of the efficiency models of each data center component. Hence, the component loss and efficiency models for different elements of the data center are derived in this section which considers the system load variations.

A component's losses can be computed as the sum of three losses: No-load loss, Proportional Loss, and Square-law loss as shown in (1). The no-load losses are fixed losses independent of the output power. The proportional losses are the losses that vary proportionately with the load (like switching loss in power semiconductors, gate drive loss, core losses in magnetics, etc.). The square losses are the losses that increase with the square of the load current (the  $I^2R$  losses). Typical efficiency curves of components, such as a UPS, shows that the efficiency decreases at very light loads, rapidly increases with medium IT loads, and then it increases slowly or saturates at higher loads.

$$P_{Loss} = P_{Loss}^{NoLoad} + P_{Loss}^{Proportional} + P_{Loss}^{Square} \quad (1)$$

Eqn. (1) can be modified using component load as the percentage of the rated active power. The component loss can be computed by using (2).

$$P_{loss} = K_0 + K_1L_{\%} + K_2L_{\%}^2 \quad (2)$$

where  $L_{\%}$  is the component load as the percentage of its rated active power, and  $K_0$ ,  $K_1$ , and  $K_2$  are the no-load, proportional, and square-law term loss coefficients, respectively, that are determined through curve fit of the loss data provided by the manufacturer at multiple load levels. Typical load levels that are available from the manufacturer are 0% (no-load), 25%, 50%, 75% and 100% (full load). The component losses are computed by subtracting the output power from the input power using (3).

$$P_{loss} = P_{in} - P_{out} \quad (3)$$

The component loss can be normalized as the percentage of its rated power as:

$$P_l = K_{p0} + K_{p1}L_{\%} + K_{p2}L_{\%}^2, \quad (4)$$

where  $P_l = \frac{P_{loss}}{P_{rated}}$ , and  $K_{pz} = \frac{K_z}{P_{rated}}$  for  $z = 0, 1, 2$ .

The loss data for the data center equipment, such as double conversion AC UPS, 400 V DC UPS, 208V AC PSU, 400V DC PSU, etc. used in the benchmark were taken from [5], [13], [24]–[26]. As, the values of the per-unit component losses  $P_l$  at different loading (obtained from manufacturer specifications) and the component's per unit load  $L_{\%}$  are known, curve fitting based on the least-squares method is used to determine the values of the loss term coefficients:  $K_{p0}$ ,  $K_{p1}$ , and  $K_{p2}$ . The no-load, proportional, and square-law term coefficients for the converters are listed in Table 1.

TABLE 1. No-load, proportional, and square-law item coefficients.

Component	Loss item coefficients		
	$K_{p0}$	$K_{p1}$	$K_{p2}$
Typical LBNL AC UPS	0.0147	0.0768	0.0397
DC UPS	0.01520	-0.00280	0.10230
240V AC PSU	0.06020	-0.09320	0.0493
DC PSU	0.06410	-0.11770	0.11240
PV Inverter	0.02850	0.00770	0.06020
Distribution Transformer	0.00290	-0.00150	0.01430
400V DC Multi-pulse rectifier	0.00130	0.00730	0.02780
SiC based front-end rectifier	0.0042	0.0054	0.0056
GaN based DC-DC converter	0.0172	0.-0149	0.0392

To build the efficiency models for the converters, we consider the efficiency of any converter at any instant that can be computed using (5).

$$\eta = \frac{P_{out}}{P_{in}} = \frac{P_{out}}{P_{out} + P_{loss}} \quad (5)$$

The load and loss in (5) can be expressed as the percentage of rated power:

$$\eta = \frac{L_{\%}P_{rated}}{L_{\%}P_{rated} + P_lP_{rated}} = \frac{L_{\%}}{L_{\%} + P_l} \quad (6)$$

Using the loss data, the efficiency models were then derived [27]. The equations representing the efficiency models of the converters are listed in Table 2.

TABLE 2. Efficiency models of the power converter used in data center benchmark.

Component	Efficiency Model
Typical LBNL AC UPS	$0.1173P^3 - 0.296P^2 + 0.2307P + 0.832$
DC UPS	$0.1813P^3 - 0.432P^2 + 0.3122P + 0.88$
240V AC PSU	$0.7573P^3 - 1.752P^2 + 1.1307P + 0.62$
DC PSU	$0.736P^3 - 1.736P^2 + 1.324P + 0.621$
PV Inverter	$0.2133P^3 - 0.552P^2 + 0.4527P + 0.798$
Distribution Transformer	$0.5436P^5 - 1.7471P^4 + 2.1709P^3 - 1.3121P^2 + 0.3842P + 0.9453$
400V DC Multi-pulse rectifier	$-0.008P^2 - 0.0116P + 0.9845$
SiC based front-end rectifier	$-0.2209P^4 + 0.5937P^3 - 0.5914P^2 + 0.2648P + 0.9388$
GaN based DC-DC converter	$0.5201P^3 - 1.0838P^2 + 0.7047P + 0.8212$

Finally, the energy efficiency of the data center power distribution system without PV integration over a year can be calculated using (7).

$$\eta_{without PV} = \frac{\sum_{i=1}^{8760} E_{IT, i}}{\sum_{i=1}^{8760} E_{Utility, i}} \quad (7)$$

where  $i$  is the number of hours and  $E_{IT, i}$  and  $E_{Utility, i}$  represent the total energy consumed by the IT load and total energy supplied by the utility at the  $i^{th}$  hour respectively. In the same way, the energy efficiency of the data center power distribution system with PV integration over a year can

be calculated using (8).

$$\eta_{with PV} = \frac{\sum_{i=1}^{8760} E_{IT, i}}{\sum_{i=1}^{8760} [E_{Utility, i} + E_{PV, i}]} \quad (8)$$

where  $E_{PV, i}$  represents the energy supplied by PV in the  $i^{th}$  hour. In the above equations, to calculate energy efficiency,  $\sum_{i=1}^{8760} E_{IT, i}$  can be calculated by summing the hourly data center load from the data center load profile, shown in Fig. 4. However, to calculate  $\sum_{i=1}^{8760} E_{Utility, i}$ , the IT power at each hour is divided by the efficiencies of the converters (as described in Table 2) in the distribution path at that hour, then summed.

### V. RELIABILITY MODELING AND ANALYSIS USING MONTE CARLO SIMULATIONS

This section presents the assumptions made for reliability modeling. It is assumed that the electronic equipment are operating in their “useful life” and have a constant failure rate lifetime denoted by  $\lambda$  (failures/hr). This assumption is based on the fact that data center components are typically replaced when they reach the end of their lifetime because of reliability concerns. Further, the failure rate follows an exponential statistical life distribution. Similarly, it is also assumed that all the components have an exponential repair distribution. The repair rates of most components denoted by  $\mu$  (repairs/hr) are assumed to be constant over their lifetime as well. However, some of the high quality utility components have non-constant repair rates and follows a Weibull distribution [28]. Table 3 shows the component failure rates and repair rates used for the modeling in this paper in terms of the Mean Time Between Failures (MTBF) and Mean Time To Repair (MTTR).

TABLE 3. Equipment reliability data [8].

Component	Inherent Availability (%)	$\frac{1}{\lambda}$ =MTBF (hours)	$\frac{1}{\mu}$ =MTTR (hours)
High Quality Utility	99.9705	8030	Weibull Distribution $\eta = 0.02,$ $\beta = 0.25$
Diesel Generator	99.997423	2000	4
Circuit Breaker	99.999989	$1 \times 10^6$	2
Bus Bars/Switch Board	99.999210	$4.38 \times 10^6$	9
Automatic Transfer Switch	99.999950	$1 \times 10^6$	2
3-phase Rectifier	99.990100	20000	2
3-phase Inverter	99.990100	20000	2
DC-DC Converter	99.996000	50000	2
Lead Acid Battery	99.996667	$240 \times 10^3$	8
Isolation Transformer	99.999937	$7.8 \times 10^6$	6
Static Bypass Switch	99.997334	$300 \times 10^3$	8

Availability is the ratio expressed as the percentage of time a system or a component can perform its required function. Availability is a dimensionless quantity

TABLE 4. Availability and downtimes.

Availability (number of 9s)	Downtime per year	Downtime per day
1	36.5 days	2.4 hours
2	3.65 days	14.4 minutes
3	8.76 hours	1.44 minutes
4	52.56 minutes	8.66 seconds
5	5.26 minutes	864.3 milliseconds
6	31.5 seconds	86.4 milliseconds
7	3.15 seconds	8.64 milliseconds
8	315.569 milliseconds	0.864 milliseconds
9	31.5569 milliseconds	0.0864 milliseconds

given by (9).

$$Availability = \frac{MTBF}{MTBF + MTTR} \quad (9)$$

The availability is typically expressed in terms of “number of 9s.” For example, “five 9s” would represent an availability of 99.999% and so on. Table 4 shows the downtime per year and per day for different availability values. In this paper, “inherent availability” is used, which neglects the downtime for preventive maintenance as this data was not available. If the data for preventive maintenance downtime is available, the “achieved availability” can be computed using (10).

$$Achieved Availability = \frac{MTBM}{MTBM + \bar{M}} \quad (10)$$

where  $MTBM$  represents the mean time between maintenance actions and  $\bar{M}$  represents the mean maintenance downtime.

Availability of a distribution system alone does not provide any information about the frequency of outages during a time period of its operation. For two different systems with a similar availability, the frequency of outages will be the only distinguishing factor when these systems are compared. MTBF provides information about the frequency of outages to expect from a system.

For complex systems with a large number of series and parallel connections, the direct analytical method such as Reliability Block Diagram (RBD) would be impractical. In the RBD approach, the MTBF of the overall systems is determined through computations at each connection point which can get complicated and time-consuming. Also, the fact that, components such as stand-by generators and battery back-up (activated only when the primary power source fail) further complicates the analysis. If the components are assumed to be repairable, the mathematical calculations become complex. Hence, to overcome these difficulties, Monte Carlo simulation was used. A software package called Powertech Analyst Enterprise [29] was used for this purpose. Once the failure and repair distributions of all the components are known, a Monte Carlo simulation is performed to model the reliability of the system. In this simulation, a random number between 0 and 1 is generated that represents the probability that an event occurs at a given time. In our case, the failure distribution model was sampled to calculate the time between

failure (TBF) based on the random number generated. Similarly, for the repair process, the time to repair (TTR) was generated by sampling the repair distribution model. Then the process is repeated to find another set of TBF and TTR. These TBF and TTR are added and updated until it reaches the total simulation time set. The number of failures are tracked and is used to calculate MTBF and MTTR as:

$$MTBF = \frac{\sum_{i=1}^N TBF_i}{N}, \quad (11)$$

$$MTTR = \frac{\sum_{i=1}^N TTR_i}{N}, \quad (12)$$

where  $N$  is the number of failures counted,  $TBF_N$  and  $TTR_N$  are the time to failure and time to repair the component for  $N_{th}$  failure. Finally, the availability can be calculated using (9). A general definition of failure as described in [8] is used in this work. The inability of the distribution system to supply electrical power to critical IT loads in a data center is counted as a failure.

### VI. EFFICIENCY ANALYSIS RESULTS

The efficiency analysis of the data center benchmark is divided into three cases: Efficiency analysis without PV integration, efficiency analysis with PV integration, and efficiency analysis of 380V DC system with WBG devices.

#### A. CASE I: EFFICIENCY ANALYSIS WITHOUT PV

The efficiency analysis results of AC and 380V DC benchmarks without PV are presented in this section. The efficiency of both AC and DC data center benchmark described in Section III neglecting the PV integration was carried out for the entire year (2011). Fig. 7 shows efficiency for the AC and DC data center for July 8, 2011. The efficiency for the DC data center is consistently higher than the AC data center. The minimum and maximum efficiency for AC data center was found to be 64.65% and 70.00%, respectively. The average efficiency over a year for AC data center was 67.41%. Similarly, for DC data center the minimum and maximum efficiency for DC data center was found to be 69.83% and 75.89%, respectively, and the average efficiency was 72.96%.

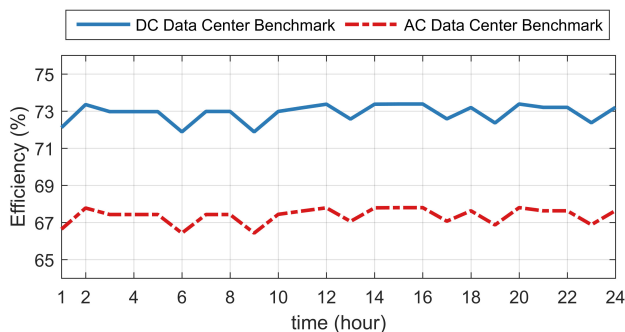

FIGURE 7. Hourly efficiency plot for AC and DC data center without PV integration, July 8, 2011.

#### B. CASE II: EFFICIENCY ANALYSIS WITH PV

The efficiency analysis was performed with a 30 MW and 50 MW PV plant for both AC and 380V DC data centers. The hourly efficiency plot of AC and 380V DC data centers at different PV plant sizes for July 8, 2011 are shown in Fig. 8. As in Case I, the efficiency of the DC data center is relatively higher compared to that of the AC data center. The efficiency drops slightly during the day when PV power reaches its maximum values in both cases. The integration of PV adds another conversion stage which incurs some additional losses in the system. Moreover, the efficiency for a higher degree of penetration is lower as expected as this incurs higher losses in the PV converter. Even though addition of PV adds to the losses, it is noteworthy that the transmission and distribution losses of the grid are neglected in this study. Thus, the additional losses does not lead to an economic disadvantage for the data center, but contributes to their sustainability efforts.

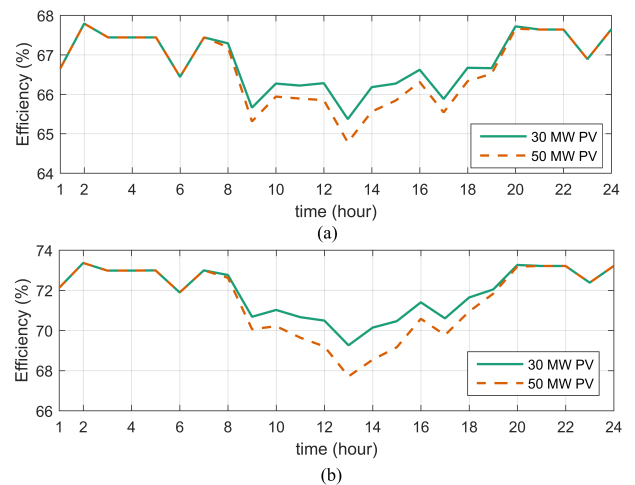
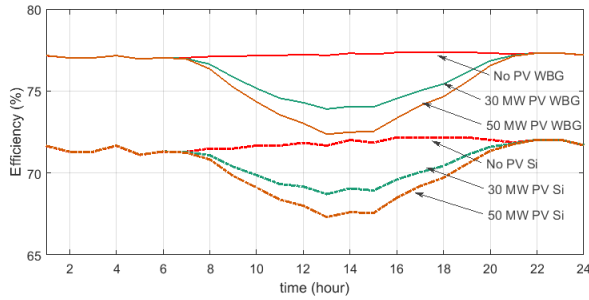

FIGURE 8. Hourly efficiency plot: AC and DC data center with PV, July 8, 2011: a) AC system and b) 380V DC system.

#### C. CASE III: EFFICIENCY ANALYSIS OF 380V DC SYSTEM WITH WBG DEVICES

In this case, the efficiency analysis of the 380V DC power distribution system is performed by replacing the Si-based front-end rectifier with SiC-based rectifier and Si based DC-DC converter in PSU with GaN-based DC-DC converter. The data to model the component loss and efficiency with WBG semiconductors were obtained from [13], [14]. Fig. 9 shows the hourly efficiency plot of the overall system using SiC based front end rectifier and GaN DC-DC PSU converters. The efficiency analysis of 380V DC system with WBG devices was performed with 30 MW and 50 MW PV plants. The overall efficiency of the system was higher than when traditional Si devices were used. Again, the efficiency drops slightly as in the previous cases with increase in PV penetration during the day, but the efficiency was still found to be higher than that of a data center using traditional Si devices as WBG devices are more efficient.



**FIGURE 9.** Hourly efficiency plot of 380V DC data center using SiC based front-end rectifier and GaN based DC-DC converter in PSU (without PV and with PV) for July 8, 2011.

**D. EFFICIENCY AND POWER USAGE EFFECTIVENESS COMPARISON**

Fig. 10 (a) shows the bar graph showing efficiencies of AC and 380 V DC power distribution architectures for different sizes of PV plant.

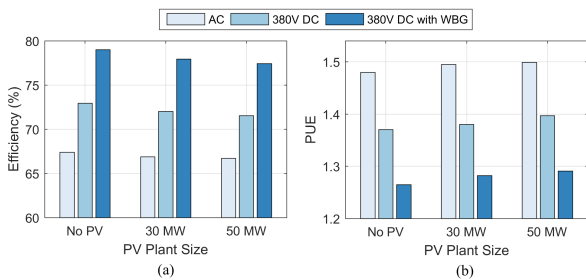

**FIGURE 10.** (a) Efficiency comparison and (b) PUE comparison at different PV plant sizes.

From the above results, it is clear that 380V DC power distribution system in data centers is more efficient than typical AC power distribution system with or without PV integration. However, the efficiency decreases with increase in PV plant size due to the extra conversion stage in the PV path. A 380V DC power distribution system is more efficient than AC by: 5.55% compared to system without PV installation; 5.13% compared to system with 30 MW PV installation; 4.85% compared to system with 50 MW PV installation.

Ideally, the value of PUE of a data center should be 1, a lower PUE value indicates a more efficient data center. The PUE of all the above cases were calculated for a year and are shown in Fig. 10 (b). PUE of 380V DC system is superior to typical AC system for all the cases for the data center benchmark used. PUE of 380V DC system using WBG based converters has a better PUE value at all PV plant sizes. Again, the higher PUE value with increase in PV plant size is due to an extra conversion stage in the PV path.

**VII. RELIABILITY ANALYSIS RESULTS**

Both AC and DC topologies were modeled using Analyst Enterprise software with the failure and repair data in Table 3.

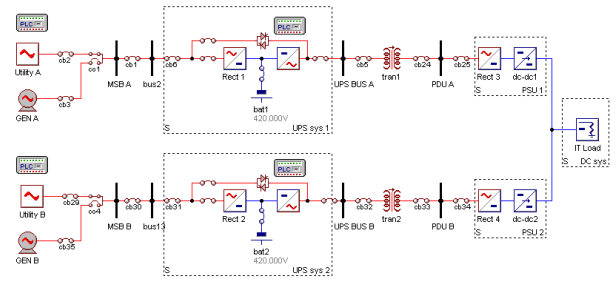

**FIGURE 11.** Simulation model of 480V AC “2N” topology.

The electrical parameters and the reliability data for each component were entered in the software for all the components. The load in the simulation is set to “cannot fail” to follow the system failure definition. The red connections in Fig. 11 and Fig. 12, represent AC connections, and the blue connections represent DC connections. Two cases were considered for reliability studies for both topologies. One with only a single active UPS per path and the other with multiple UPSs per path with “N+1” redundancy. The effect of intermittency of PV generation on the reliability of the system has not been considered in this paper.

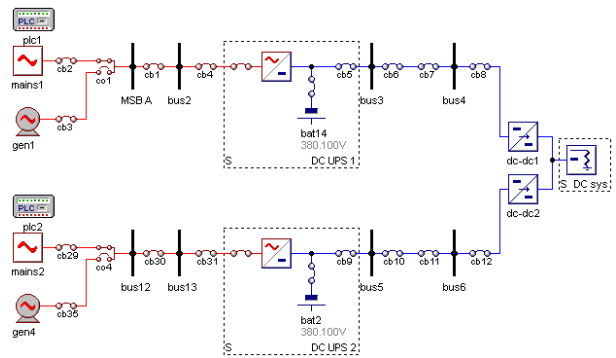

**FIGURE 12.** Simulation model of 380V “2N” DC topology.

**A. CASE I: SINGLE ACTIVE UPS PER PATH**

The most basic topology for UPS connection in Tier-IV data centers with “2N” component redundancy is using a single UPS per path, with separate battery banks for UPS in each path. At normal operating condition, each UPS will be operating at 50% load (max). When one of the UPSs fails, the path containing that UPS goes out of service. Until the UPS has been repaired and the service is restored, the only way to maintain uninterrupted power supply to the IT load is via another power distribution path where the UPS can handle the full load.

The working simulation model of 480V AC “2N” distribution system in a data center developed in Analyst Enterprise simulation software is shown in Fig. 11. The simulation time was set to 5,000,000 hours. At the end of the simulation, failure rate of AC system was found to be  $7.042 \times 10^{-3}$  failures/year. The failure rate of the 380V



DC “2N” distribution system in Fig. 12 is  $4.255 \times 10^{-3}$  failures/year. The failure rate of DC system is 40% less than that the AC system. The additional conversion stages in AC system led to higher failure rate governed by the individual failure rates of those components listed in Table 3. Hence, the DC system is more reliable than the AC system, as the DC system has higher MTBF and a relatively low MTTR, as shown in Table 5.

**TABLE 5. Monte-carlo simulation results.**

Distribution System	MTBF (hours)	MTTR (hours)	Availability (number of 9s)
480V AC “2N”	1,243,920	3.73875	5
380V DC “2N”	2,058,600	1.60630	6
480V AC “2(N+1)”	3,328,800	0.07656	7
380V DC “2(N+1)”	3,740,520	0.04488	7
480V AC “2(N+2)”	9,995,160	< 60 seconds	9
380V DC “2(N+2)”	10,985,040	< 60 seconds	9

### B. CASE II: MULTIPLE ACTIVE UPS PER PATH WITH “N+1” REDUNDANCY

This topology has an additional UPS in each path to have “N+1” redundancy. It is considered that two active UPSs are used per path out of which one UPS is required to supply the IT load. In this case, each UPS will be operating at 25% load capacity at normal condition. Both the UPSs are able to supply the IT load when the other UPS system fails. The UPS system is designed in such a way that a single UPS can handle full data center load. For the distribution path to go out of service, both UPSs have to fail at the same time.

The simulation setup in Analyst Enterprise simulation software is the same as in Case I apart from the fact that there two active paths per UPS. The simulation time was kept the same, 5,000,000 hours, as the previous case. The failure rate of this system was found to be  $2.631 \times 10^{-3}$  failures/year, which is clearly less frequent than the AC system with a single UPS per path in the previous case. The failure rate of the DC system with “N+1” UPS system is  $2.341 \times 10^{-3}$  failures/year, which is better than the DC system with a single UPS per path. In this case (“N+1” UPS redundancy), failure rate of the DC system is 12% less than that of the AC system. In both cases, the DC system has higher MTBF and lower MTTR, as shown in Table 5. The level of redundancy in the UPS system was further increased to “N+2” and the reliability simulations was carried out. The simulation results shown in Table 5 tells us that the difference in the MTBF, MTTR, and availability of AC and DC systems are less as compared to previous UPS redundancy levels. This shows that, as the level of redundancy increases, the difference in MTBF, MTTR and availability of AC and DC systems will decrease.

It can be seen in Table 5 that the MTBF of both AC and DC topologies increased with the increase in UPS redundancy. This is due to additional paths for the power distribution. For instance, in the case of “2(N+1)” topology, which will have two parallel paths for power delivery, if we assume that the upper distribution path failed at time  $t$ , which could be

due to failure of both UPSs or failure of the component(s) along the path. Again, if we assume that the lower distribution path failed at time  $t + \Delta t$ ,  $\Delta t$  seconds after failure in the upper distribution path. Up to time,  $t + \Delta t$  seconds, the IT load gets the power until both distribution path fails. Now, if the upper distribution path recovers from failure at time,  $t + \Delta t + \Delta t'$ , that is,  $\Delta t'$  seconds after failure of both paths. The downtime of the system is just  $\Delta t'$  seconds. Due to the time overlap of failure of distribution paths in the system, higher number of distribution paths results in lower MTTR values. The results shows that both AC and DC distribution systems with “2(N+2)” UPS redundancy has the lowest MTTR values.

### VIII. CONCLUSIONS

A method to improve data center’s efficiency and reliability has been presented in this paper. A 380 V DC power distribution architecture has been utilized to obtain improved efficiency and higher reliability in data center power distribution system. The effect of solar integration on the overall system efficiency shows that 380 V DC distribution system is more efficient than the typical AC distribution system for both PV installation sizes of 30 MW and 50 MW. The impact of converters using WBG technology on a 380 V DC power distribution architecture was more efficient than that using Si based converters. The reliability analyses of both AC and DC powering option for power distribution in data centers shows that 380 V DC distribution system is more reliable than a typical AC distribution system up to a certain level of redundancy in the UPS systems. As the number of UPSs in each path is increased, the values of reliability metrics such as MTBF and MTTR of the AC system will approach the reliability metrics values of the DC system.

### REFERENCES

- [1] N. Deng, C. Stewart, and J. Li, “Concentrating renewable energy in grid-tied datacenters,” in *Proc. IEEE Int. Symp. Sustain. Syst. Technol.*, May 2011, pp. 1–6.
- [2] Ponemon Institute, “Cost of data center outages,” Ponemon Inst., Traverse City, Michigan, Tech. Rep., 2016.
- [3] A. Pratt, P. Kumar, and T. V. Aldridge, “Evaluation of 400 V DC distribution in telco and data centers to improve energy efficiency,” in *Proc. 29th IEEE Int. Telecommun. Energy Conf. (INTELEC)*, Sep. 2007, pp. 32–39.
- [4] W. Turner, J. H. Seader, and W. Renaud, “Data center site infrastructure tier standard: Topology,” Uptime Institute, 2010. [Online]. Available: [https://uptimeinstitute.com/uptime\\_assets/d60e4b92ffa912e586a68d76617c4f12c3700681477064382a03207927a1ee96-00001A.pdf](https://uptimeinstitute.com/uptime_assets/d60e4b92ffa912e586a68d76617c4f12c3700681477064382a03207927a1ee96-00001A.pdf)
- [5] N. Rasmussen and J. Spitaels, “A quantitative comparison of high efficiency AC vs. DC power distribution for data centers,” Amer. Power Convers., Schnieder Electr., South Kingstown, Rhode Island, White Paper, 2007, vol. 127.
- [6] Y. Li, L. He, F. Liu, C. Li, Y. Cao, and M. Shahidehpour, “Flexible voltage control strategy considering distributed energy storages for DC distribution network,” *IEEE Trans. Smart Grid*, to be published, doi: 10.1109/TSG.2017.2734166.
- [7] M. Zhang, Y. Li, F. Liu, L. Luo, Y. Cao, and M. Shahidehpour, “Voltage stability analysis and sliding-mode control method for rectifier in DC systems with constant power loads,” *IEEE J. Emerg. Sel. Top. Power Electron.*, vol. 5, no. 4, pp. 1621–1630, Dec. 2017.
- [8] C. Heising et al., *IEEE Recommended Practice for the Design of Reliable Industrial and Commercial Power Systems*, IEEE Standard 493-2007 (Revision of IEEE Standard 493-1997, IEEE Inc., New York, NY, USA, 2007.

- [9] B. R. Shrestha, T. M. Hansen, and R. Tonkoski, "Reliability analysis of 380 V DC distribution in data centers," in *Proc. IEEE Power Energy Soc. Innov. Smart Grid Technol. Conf.*, Sep. 2016, pp. 1–5.
- [10] I. Goiri, W. Katsak, K. Le, T. D. Nguyen, and R. Bianchini, "Parasol and greenswitch: Managing datacenters powered by renewable energy," *SIGARCH Comput. Archit. News*, vol. 41, no. 1, pp. 51–64, Mar. 2013.
- [11] E. Oró, V. Depoorter, A. Garcia, and J. Salom, "Energy efficiency and renewable energy integration in data centres. Strategies and modelling review," *Renew. Sustain. Energy Rev.*, vol. 42, pp. 429–445, Feb. 2015.
- [12] MidAmerican Energy. *Google and MidAmerican Energy Company Announce Renewable Energy Agreement in Iowa*. Accessed: Nov. 10, 2016. [Online]. Available: <http://www.midamericanenergy.com/>
- [13] W. Zhang *et al.*, "Wide bandgap power devices based high efficiency power converters for data center application," in *Proc. IEEE Workshop Wide Bandgap Power Devices Appl.*, Oct. 2014, pp. 121–126.
- [14] F. Xu, B. Guo, L. M. Tolbert, F. Wang, and B. J. Blalock, "Design and performance of an all-SiC three-phase buck rectifier for high efficiency data center power supplies," in *Proc. IEEE Energy Convers. Congr. Expo.*, Sep. 2012, pp. 2927–2933.
- [15] M. Murrill and B. Sonnenberg, "Evaluating the opportunity for DC power in the data center," Emerson Netw. Power White Paper, Warrenville, IL, USA, Tech. Rep. 124W-DCDATA, 2011.
- [16] A. Matsumoto, A. Fukui, T. Takeda, and M. Yamasaki, "Development of 400-VDC output rectifier for 400-VDC power distribution system in telecom sites and data centers," in *Proc. 32nd IEEE Int. Telecommun. Energy Conf.*, Jun. 2010, pp. 1–6.
- [17] R. Cuzner, "Does DC distribution make sense?" *IEEE Electr. Mag.*, vol. 4, no. 2, Jun. 2016, doi: [10.1109/MELE.2016.2543978](https://doi.org/10.1109/MELE.2016.2543978).
- [18] S. R. Awasthi, S. Chalise, and R. Tonkoski, "Operation of datacenter as virtual power plant," in *Proc. IEEE Energy Convers. Congr. Expo.*, Sep. 2015, pp. 3422–3429.
- [19] SolarAnywhere. *Solar Irradiance Data*. Accessed: Mar. 5, 2016. [Online]. Available: <http://www.solaranywhere.com/>
- [20] D. Erbs, S. Klein, and J. Duffie, "Estimation of the diffuse radiation fraction for hourly, daily and monthly-average global radiation," *Sol. Energy*, vol. 28, no. 4, pp. 293–302, 1982.
- [21] J. A. Duffie and W. A. Beckman, *Solar Engineering of Thermal Processes*, 4th ed. Hoboken, NJ, USA: Wiley, 2013.
- [22] R. Messenger and A. Abtahi, *Photovoltaic Systems Engineering*. Boca Raton, FL, USA: CRC Press, 2010.
- [23] National Renewable Energy Laboratory. *NREL RSF Measured Data 2011*. Accessed: Jan. 21, 2016. [Online]. Available: <http://en.openei.org/datasets/dataset/nrel-rsf-measured-data-2011>
- [24] A. Driesse, P. Jain, and S. Harrison, "Beyond the curves: Modeling the electrical efficiency of photovoltaic inverters," in *Proc. IEEE Photovoltaic Specialists Conf.*, May 2008, pp. 1–6.
- [25] T. L. Baldwin, R. J. Turk, K. S. Myers, J. P. Gentle, and J. W. Bush, "Transformer efficiency assessment-Okinawa, Japan," Idaho Nat. Lab., Idaho Falls, ID, USA, Tech. Rep. INL/EXT-12-26145, 2012.
- [26] S. A. Hamidi, A. Nasiri, and Z. Tiefert, "Rectifier efficiency analysis for DC distributed data centers," in *Proc. IEEE Renew. Energy Res. Appl.*, Oct. 2014, pp. 776–779.
- [27] B. R. Shrestha, "Efficiency and reliability analysis of AC and 380 V DC data centers," M.S. thesis, Dept. Elect. Eng. Comput. Sci., South Dakota State Univ., Brookings, SD, USA, 2016.
- [28] M. Xie and C. D. Lai, "Reliability analysis using an additive Weibull model with bathtub-shaped failure rate function," *Rel. Eng. Syst. Saf.*, vol. 52, no. 1, pp. 87–93, Apr. 1996.
- [29] Powertech. (2016). *Analyst Enterprise*. Accessed: Feb. 1, 2016. [Online]. Available: <http://www.powertech.com.au/software-analyst-enterprise.html>



**BIJEN R. SHRESTHA** received the B.E. degree in electrical engineering from the Pulchowk Campus, Institute of Engineering, Lalitpur, Nepal, in 2011, and the M.S. degree in electrical engineering from South Dakota State University, Brookings, SD, USA, in 2016.

He was an Electrical Engineer for 2 years in a data center in Nepal. He is currently a Data Center Field Engineer at Amazon, Inc. His main research interests cover the design of efficient and reliable power distribution system in data centers. His research interests also include electrical power generation, transmission and distribution, renewable energy integration, and power system control and protection.



**UJJWOL TAMRAKAR** (S'14) received the B.E. degree in electrical engineering from Tribhuvan University, Nepal, in 2011, and the M.S. degree in electrical engineering from South Dakota State University (SDSU), Brookings, SD, USA, in 2015, where he is currently pursuing the Ph.D. degree in electrical engineering. His research interests include power electronics and control, grid integration of renewable energy systems, power system stability, and power quality.



**TIMOTHY M. HANSEN** (S'07–GS'11–M'15) received the B.S. degree (Hons.) from the Milwaukee School of Engineering, Milwaukee, WI, USA, in 2011, and the Ph.D. degree from Colorado State University, Fort Collins, CO, USA, in 2015.

He is currently an Assistant Professor with the Electrical Engineering and Computer Science Department, South Dakota State University, Brookings, SD, USA. His current research interests include robust resource allocation and optimization applied to cyber-physical-social systems, electric power engineering and markets, and high-performance computing.



**BISHNU P. BHATTARAI** (S'12–M'15–SM'18) received the M.Sc. degree in power system engineering from Tribhuvan University, Nepal, and Osaka Sangyo University, Japan, in 2010, and the Ph.D. degree in electrical engineering from Aalborg University, Denmark, in 2015. He was with the Idaho National Laboratory, USA, on various aspects of microgrid and cyber-physical security of the electric grid infrastructure. He was also a Visiting Scholar at the Institut National de la

Recherche Scientifique, Canada, where he was involved in the development and demonstration of physical smart grid testbed using power and communication resources. He is currently a Senior Research Scientist/Engineer at the Pacific Northwest National Laboratory, Richland, WA, USA. His research interests include the grid integration of distributed energy resources, advanced modeling and simulation of power and communication systems, smart grids, transactive energy systems, demand response, cyber-physical security of grid infrastructure, and distribution system resiliency. He was a recipient of the Nepal Government's Prestigious Gold Medal Award from the President of Nepal for his best performance during graduate studies and the Green Talent Awards 2017 from the German Federal Ministry of Education and Research for outstanding contributions in the field of sustainable energy systems.



**SEAN JAMES** runs the Microsoft’s Datacenter Research and Development Program within the Microsoft Cloud Infrastructure and Operations Group. He drives new datacenter technology for Microsoft’s next-generation data centers, including the evaluation, development, and testing.

He joined Microsoft in 2006 to manage one of Microsoft’s datacenters. Later, he joined the Construction Team and oversaw the design and building of new Microsoft datacenters.

Prior to joining Microsoft, he worked in datacenter management overseeing the day-to-day maintenance and repair operations for both IT hardware and critical infrastructure, such as electrical infrastructure and cooling equipment. Prior to joining Microsoft, he has served in the US Navy Submarine Fleet as an Electrician. He holds many patents related to datacenters and energy, a computer science degree, and is a certified Project Management Professional from the Project Management Institute.



**REINALDO TONKOSKI** (S’04–M’11–SM’18) received the B.A.Sc. degree in control and automation engineering and the M.Sc. degree in electrical engineering from the Pontifical Catholic University of Rio Grande do Sul, Brazil, in 2004 and 2006, respectively, and the Ph.D. degree from Concordia University, Canada, in 2011. He was with CanmetENERGY, Natural Resources Canada, from 2009 to 2010, where he was involved in projects related to the grid integration of renewable

energy sources.

He is currently an Associate Professor with the Electrical Engineering and Computer Science Department, South Dakota State University, Brookings, USA. He has authored over 80 technical publications in peer-reviewed journals and conferences. His research interests include the grid integration of renewable energy systems and batteries, distributed generation, power quality, and power electronics.

• • •