

Received September 12, 2018, accepted October 11, 2018, date of publication October 16, 2018, date of current version November 30, 2018.

Digital Object Identifier 10.1109/ACCESS.2018.2876193

An ME-SMIB Based Method for Online Transient Stability Assessment of a Multi-Area Interconnected Power System

SONGHAO YANG^{1,2}, (Student Member, IEEE), BAOHUI ZHANG¹, (Senior Member, IEEE), MASAHIDE HOJO², (Member, IEEE), AND FU SU³

¹State Key Laboratory of Electrical Insulation and Power Equipment, Xi'an Jiaotong University, Xi'an 710049, China

²Department of Electrical and Electronic Engineering, The University of Tokushima, Tokushima 7708502, Japan

³State Grid Sichuan Electric Power Dispatching Control Center, Chengdu 610041, China

Corresponding author: Songhao Yang (songhaoyang@stu.xjtu.edu.cn)

This work was supported by the Key Project of Smart Grid Technology and Equipment of National Key Research and Development Plan of China under Grant 2016YFB0900600.

ABSTRACT Transient stability assessment (TSA) of the power system is essential to the safe operation of the power grid. The TSA of the multi-area interconnected power system is a challenging task due to its special multi-area power grid structure. New features, which are the time-variable instability mode and untypical two-group instability mode, emerge in the transients of the interconnected power system and affect the accuracy of conventional TSA methods. To address these problems, we propose a novel TSA method based on the modified equivalent single machine infinite bus (ME-SMIB) system. Two key technologies, namely generator groups identification and generator selection, were presented in the proposed method. Generator groups were identified at each time-step to track the time-variable instability mode. Two groups of generators that were of good coherency and closely related to the current instability mode were selected to construct the ME-SMIB system. The transient instability was finally identified by the concave-convexity-based method. The proposed method was tested in the 16-generator 68-bus power system and China interconnected power system. Results show that the proposed ME-SMIB system can avoid the misjudgments caused by new transient features of the multi-area interconnected power system, presenting superior reliability than the conventional E-SMIB system.

INDEX TERMS Transient stability assessment, interconnected power system, generator selection, generator group, E-SMIB, concave-convexity of phase trajectory.

NOMENCLATURE

A the unified representation of generator group
 c concave-convexity index/instability index
 C group of original critical machines
 C_s group of selected critical machines
 M inertia constant of the ME-SMIB system
 M_i inertia constant of the i -th generator
 N group of original non-critical machines
 N_s group of selected non-critical machines
 P_e electrical power of the ME-SMIB system
 P_{ei} electrical power of the i -th generator
 P_m mechanical power of the ME-SMIB system
 P_{mi} mechanical power of the i -th generator
 δ rotor angle of the ME-SMIB system
 δ_i rotor angle of the i -th generator
 δ_u the angle of the unstable equilibrium point (UEP)
 σ_A coherency index of group A

$\sigma_{r,A}$ normalized coherency index of group A
 $\Delta\omega$ rotor speed deviation of the ME-SMIB system
 $\Delta\omega_i$ rotor speed deviation of the i -th generator

I. INTRODUCTION

The continuous growth of the load demand leads to the fast expansion of the power grid. More interconnections among existing power grids are built to reduce the cost of grid operation, resulting in an ever-greater multi-area interconnected power system [1]. The examples of such systems can be the ENTSO-E system, the NERC Bulk power system and China Liang-Hua interconnected power system [2]. Despite the advantages of higher energy efficiency and stronger adaptability to the high penetration of renewable energy generation [3], the interconnected power systems also suffer higher risks of large disturbances. If the transient instability of the

system cannot be identified quickly or the emergency controls cannot be taken properly [4] when the system is disturbed, a severe power blackout will arise and result in catastrophic losses. Therefore, the transient stability assessment (TSA) of power system turns out to be essential to the safe operation of the multi-area interconnected power grid.

The TSA of the interconnected power system is a challenging task due to the large grid size and the special multi-area grid structure. The growth of the grid size inevitably increases the computational efforts and communication burdens of the TSA. To this end, a computationally efficient state estimator based on a two-stage multi-area estimation approach was proposed, aiming to minimize the effects of the growing system size on state estimation [5]. For more efficient transient stability simulation, simplified methods were also adopted based on parallel GPUs [6], multi-area Thevenin equivalents [1], [7] and dimension reduction [8]–[10]. To alleviate the communication burdens of PMU based TSA methods [11]–[14], a partition-composition method [15] and a compressive sensing based strategy [16] were presented separately. However, the researches mentioned above mainly focused on the problems caused by the increasing grid size of the power system. Little attention was paid to the impacts of the multi-area grid structure on the TSA of the interconnected power system. In this paper, we will highlight this point from the perspective of the new transient features of the multi-area interconnected power system.

The impact of the grid structure on transient stability is reflected in the generators dynamic performance that depends on the electrical connections between generators and the location of the fault bus [17]. For the multi-area interconnected power system, the electrical connections inside each sub-grid are strong while the electrical connections of inter-regional corridors are relatively weak [18]. Thus, when disturbed, generators in same sub-grid tend to behave as a whole whereas generators in different sub-grids show diverse transient characteristics. The multi-area interconnected power grid, therefore, presents the following two transient features that differ from those in the isolated power systems:

a) *Time-variable instability mode*. The instability mode is used to describe the way that generators lose synchronism when the power system suffer a large disturbance. In the isolated power systems, the instability mode is mainly decided by the disturbance because the electrical connections of generators are relatively balanced. Thus, the instability mode is also called the mode of disturbance (MOD) in [11]. However, in the multi-area interconnected power system, the instability mode becomes time-variable due to the unbalanced electrical connections. If a large disturbance occurred in a sub-grid, the oscillation tends to appear within the sub-grid initially, and then spread to the interface among sub-grids. The time variability of the instability mode in the multi-area interconnected power system has been demonstrated in the 2012 India blackouts [19].

b) *Untypical two-group instability mode*. The typical two-group instability mode is an ideal assumption that the loss of synchronism originates from the irrevocable separation of generators into two coherent groups: the group C of critical machines (CMs) and the other group N of non-critical machines (NMs). However, the assumption is difficult to satisfy in the interconnected power system. When disturbed, generators will roughly separate into two groups, but they are not strictly coherent in each group, resulting in the untypical two-group instability mode. Moreover, generators may even separate into multiple (more than two) groups in some extreme situations of generator incoherency.

These transient features bring new challenges to the application of conventional TSA methods in the multi-area interconnected power system. Nowadays, the online TSA methods used in practice are either the intellectual methods and hybrid methods. The intellectual methods that are based on support vector machine [20], decision trees [21], or extreme machine learning [22]–[23] usually train a set of classifiers using offline data and then identify the transient stability with online data. These algorithms perform well when the classifiers are sufficiently trained. However, when applied to the interconnected power system, these methods face the difficulties in building an adequate training library that includes all possible instability modes. It is a time-consuming task because of the large-scale grid size and various operation modes. Moreover, the time-variable instability modes increase the difficulty of classification and reduce the reliability of transient stability identification.

The hybrid methods are the combination of the time-domain simulation methods and the direct methods. When applied to the online TSA, the hybrid methods simulate the transient response of power system under preimagined disturbances and identify the transient stability at each time-step by direct methods [11], [24] or equivalent single-machine-infinite-bus system (E-SMIB) based methods [25]–[29]. The simulation can be operated online with the static information from EMS or PMUs. The hybrid methods avoid the heavy computation burden of time-domain simulation by early ending the calculations in unstable cases and evaluate the stable margin in stable cases. However, the application of hybrid methods in the interconnected power system is limited due to their ideal theoretical assumptions. For example, the TEF methods assume that the system is in unchanged two-group instability mode and then identify the transient stability by comparing the maximum transient potential energy and transient kinetic energy at fault clearing instant [11]. But the time-variable instability mode in the interconnected power system makes it impossible to calculate the maximum potential energy. And the untypical two-group instability mode also reduces the accuracy of kinetic energy computation.

Similarly, the E-SMIB methods also assume that generators are in the typical two-group instability mode. Then the original power system can be equivalent to an E-SMIB

system that has similar transient features with the ideal SMIB system. The transient stability of the equivalent system can be identified by a relatively simple method, which provides a simplified perspective for the TSA of the interconnected power system. However, the instability mode is sometimes time-variable in the interconnected power system. Thus the E-SMIB system needs to be updated accordingly. But conventional E-SMIB methods are based on an unchanged E-SMIB system and cannot adapt to such scenarios. Also, the untypical two-group instability mode in the interconnected power system results in different transient features in the E-SMIB system from the ideal SMIB system, which may lead to severe stability misjudgments. More research is required to improve the reliability and applicability of the E-SMIB methods to the multi-area interconnected power system.

In this paper, a novel method is proposed for the online TSA of the multi-area interconnected power system. To address the problems of the time-variable instability mode and untypical two-group instability mode, we propose a Modified Equivalent Single Machine Infinite Bus (ME-SMIB) system. In the proposed method, a time-updating generator grouping scheme is used to track the time-variable instability mode, and representative generators are selected to construct the ME-SMIB system in case of the untypical two-group instability mode. The transient stability is finally evaluated based on the phase trajectory of the ME-SMIB system. The rest of the paper is organized as follows:

-Section 2 presents the theoretical basis of the proposed method.

-Section 3 introduces the details of the proposed method. The time-updating generator grouping scheme and generator selection criteria are presented.

-Section 4 verify the effectiveness of the proposed method via four scenarios in two test systems.

-Section 5 gives the conclusions and future work plan.

II. THEORETICAL ANALYSIS

A. THE CONVENTIONAL E-SMIB BASED TSA METHODS

The E-SMIB based methods assume that all generators separate into two coherent generator groups C and N when disturbed. Thus, the E-SMIB system is determined by (1).

$$\delta_r = \frac{\sum_{i \in C} M_i \delta_i}{\sum_{i \in C} M_i} - \frac{\sum_{j \in N} M_j \delta_j}{\sum_{j \in N} M_j},$$

$$\Delta\omega_r = \frac{\sum_{i \in C} M_i \Delta\omega_i}{\sum_{i \in C} M_i} - \frac{\sum_{j \in N} M_j \Delta\omega_j}{\sum_{j \in N} M_j},$$

$$M_r = \frac{\sum_{i \in C} M_i \sum_{j \in N} M_j}{\sum_{i \in C} M_i + \sum_{j \in N} M_j},$$

$$P_{er} = \frac{\sum_{j \in N} M_j \sum_{i \in C} P_{ei} - \sum_{i \in C} M_i \sum_{j \in N} P_{ej}}{\sum_{i \in C} M_i + \sum_{j \in N} M_j},$$

$$P_{mr} = \frac{\sum_{j \in N} M_j \sum_{i \in C} P_{mi} - \sum_{i \in C} M_i \sum_{j \in N} P_{mj}}{\sum_{i \in C} M_i + \sum_{j \in N} M_j}, \quad (1)$$

where δ_r , $\Delta\omega_r$, M_r , P_{er} and P_{mr} are the rotor angle, speed deviation, the inertia constant, the electrical power and the mechanical power of the E-SMIB system, separately. The electrical power of the i -th generator, P_{ei} is given in (2).

$$P_{ei} = \sum_{j=1}^n (E_i E_j B_{ij} \sin \delta_{ij} + E_i E_j G_{ij} \cos \delta_{ij}), \quad (2)$$

where δ_{ij} is the angle difference between the i -th generator and the j -th generator. E_i is the voltage behind transient reactance of i -th generator. G_{ij} and B_{ij} is the conductance and susceptance. Thus, The electrical power P_{er} can be formulated as a function of δ_r in the E-SMIB system by substituting (2) into (1).

$$P_{er} = B \sin \delta_r + D \cos \delta_r + P_c = P_{e \max} \sin(\delta_r - \gamma) + P_c, \quad (3)$$

where variables are defined as follows.

$$P_{e \max} = \sqrt{B^2 + D^2}, \quad \gamma = -\arctan \frac{B}{D}, \quad \varepsilon_i = \delta_i - \delta_A,$$

$$\delta_A = \frac{\sum_{i \in A} M_i \delta_i}{\sum_{i \in A} M_i},$$

$$B = \sum_{i \in C} \sum_{j \in N} E_i E_j B_{ij} \sin(\varepsilon_i - \varepsilon_j) + \frac{M_N - M_C}{M_T} \sum_{i \in C} \sum_{j \in N} E_i E_j G_{ij} \cos(\varepsilon_i - \varepsilon_j),$$

$$D = \sum_{i \in C} \sum_{j \in N} E_i E_j B_{ij} \cos(\varepsilon_i - \varepsilon_j) + \frac{M_C - M_N}{M_T} \sum_{i \in C} \sum_{j \in N} E_i E_j G_{ij} \sin(\varepsilon_i - \varepsilon_j),$$

$$M_C = \sum_{i \in C} M_i, \quad M_N = \sum_{j \in N} M_j, \quad M_T = M_C + M_N,$$

$$M = \frac{M_C M_N}{M_C + M_N},$$

$$P_c = \frac{M_N}{M_T} \left(\sum_{i \in C} \sum_{k \in C} E_i E_k (B_{ik} \sin(\varepsilon_i - \varepsilon_k) + G_{ik} \cos(\varepsilon_i - \varepsilon_k)) \right) \frac{M_C}{M_T} \left(\sum_{j \in N} \sum_{l \in N} E_j E_l \times (B_{jl} \sin(\varepsilon_j - \varepsilon_l) + G_{jl} \cos(\varepsilon_j - \varepsilon_l)) \right), \quad (4)$$

where ε_i is the angle distance between the i -th generator angle, δ_i and the center angle, δ_A of its belonging group.

When the power system is in a typical two-group instability mode, the requirements for the generator coherency are satisfied, namely

$$\forall i, j \in A, A = C \text{ or } N : \Delta\omega_{ij} = 0, \quad \delta_i \approx \delta_A, \quad (5)$$

where $\Delta\omega_{ij}$ is the speed difference, indicates the relative motion between generators i and j . In this case,

the angle distance, ε in (4) become small-value constants. As a result, $P_{e\max}$, γ , P_c turn out to be time-invariant parameters and P_e becomes a constant trigonometric function of δ_r . In other words, the E-SMIB system shows similar dynamic performance with the ideal SMIB system, as shown in (6).

$$\dot{\delta}_r = \omega_0 \Delta\omega_r, M_r \ddot{\delta}_r = P_{mr} - [P_{e\max} \sin(\delta_r - \gamma) + P_c], \quad (6)$$

where ω_0 is the synchronous speed.

Therefore, TSA methods deduced from the ideal SMIB system [25]–[29] can be applied to the E-SMIB system when the system shows a typical two-group instability mode.

B. THE PROPOSED ME-SMIB BASED TSA METHODS

In the multi-area interconnected power system, it is difficult to satisfy the requirements of the typical two-group instability mode in (5). Generators tend to split in an untypical two-group instability mode when subjected to a large disturbance. In such cases, ε in (4) vary with time. As a result, $P_{e\max}$, γ and P_c are time-variant parameters in (3), and P_e become a function of time as well as δ_r . In other words, the E-SMIB is a time-variant system, whose transient features are different from those of the ideal SMIB system. The differences may cause severe stability misjudgments.

To address these issues, we suggest constructing an ME-SMIB system that can not only reflect the transient features of the time-variant power system but also satisfy the E-SMIB methods requirements for the generator coherency. In this work, the ME-SMIB system is constructed based on two groups of selected generators: C_s -group and N_s -group with following characteristics.

- C_s -group and N_s -group cover a major part of whole generators, and they can represent the current instability mode of the original system;
- Generators are coherent in either C_s -group or N_s -group.

The ME-SMIB system is thus determined by the selected generators, as shown in (7).

$$\begin{aligned} \delta &= \frac{\sum_{i \in C_s} M_i \delta_i}{\sum_{i \in C_s} M_i} - \frac{\sum_{j \in N_s} M_j \delta_j}{\sum_{j \in N_s} M_j}, \\ \Delta\omega &= \frac{\sum_{i \in C_s} M_i \Delta\omega_i}{\sum_{i \in C_s} M_i} - \frac{\sum_{j \in N_s} M_j \Delta\omega_j}{\sum_{j \in N_s} M_j}, \\ M &= \frac{\sum_{i \in C_s} M_i \sum_{j \in N_s} M_j}{\sum_{i \in C_s} M_i + \sum_{j \in N_s} M_j}, \\ P_e &= \frac{\sum_{j \in N_s} M_j \sum_{i \in C_s} P_{ei} - \sum_{i \in C_s} M_i \sum_{j \in N_s} P_{ej}}{\sum_{i \in C_s} M_i + \sum_{j \in N_s} M_j}, \\ P_m &= \frac{\sum_{j \in N_s} M_j \sum_{i \in C_s} P_{mi} - \sum_{i \in C_s} M_i \sum_{j \in N_s} P_{mj}}{\sum_{i \in C_s} M_i + \sum_{j \in N_s} M_j}, \end{aligned} \quad (7)$$

where δ , $\Delta\omega$, M , P_e and P_m are the rotor angle, the speed deviation, the inertia constant, the electrical power and the mechanical power of the ME-SMIB system, separately.

Taking the i -th generator in C_s -group as an example, the electrical power can be expressed as:

$$\begin{aligned} P_{ei} \Big|_{i \in C_s} &= \sum_{k \in C_s} E_i E_k [B_{ik} \sin(\varepsilon_i - \varepsilon_k) + G_{ik} \cos(\varepsilon_i - \varepsilon_k)] \\ &+ \sum_{l \in N_s} E_i E_l [B_{il} \sin(\delta + \varepsilon_i - \varepsilon_l) + G_{il} \cos(\delta + \varepsilon_i - \varepsilon_l)] \\ &+ \sum_{\substack{m \notin C_s \\ m \in N_s}} E_i E_m [B_{im} \sin(\delta_i - \delta_m) + G_{im} \cos(\delta_i - \delta_m)] \end{aligned} \quad (8)$$

Since ε are small-value constants in this case, the first item in (8) is a constant and the second item is a trigonometric function of δ . The third item is time-varying, which shows the effects of the ignored generators on the selected generators. The influence, however, is small because the ignored generators are a minor part of all generators, and it will be partially neutralized during the subsequent transformation in (7). Thus, P_{ei} in (8) is mainly decided by first two time-invariant items and P_e turns out to be a quasi-constant trigonometric function of δ in the ME-SMIB system. It indicates that the ME-SMIB system shows weaker time-variability and better similarity to the ideal SMIB system when compared with the conventional E-SMIB system. This superiority of ME-SMIB system will surely improve the accuracy of TSA of the multi-area interconnected power system.

Additionally, the instability mode of the interconnected power system should be identified dynamically due to its time-varying characteristics. The dynamic grouping of generators can realize the task. Thus, in this work, we present a time-updating method to track the changing generator groups. Whenever the instability mode changes, the ME-SMIB system is updated by newly identified generator groups, resulting in the segmented phase trajectories and $\Delta P - \delta$ curves. It makes some transient energy-based E-SMIB methods such as EEAC and SIME inapplicable to the interconnected power system because they need a continuous integration from fault occurrence moment to the controlling UEP on the $\Delta P - \delta$ curve. Conversely, the concave-convexity based method can obtain the instability index at each step without the limitation of the continuous phase trajectories and $\Delta P - \delta$ curves [14]. Therefore, in this work, the concave-convexity based method is used to detect the transient stability of the ME-SMIB system.

III. THE ME-SMIB BASED ONLINE TSA METHOD

The ME-SMIB based TSA method is applied to evaluate the transient stability of the interconnected power system under pre-imagined disturbances. For each given pre-imagined disturbance, the scheme is executed at each time-step of the online transient simulation and gives the TSA results of the interconnected power system efficiently. It consists

of following parts: generators information input, generator groups identification, generators selection, the ME-SMIB system formation, and transient instability detection.

A. REQUIRED GENERATOR INFORMATION INPUT

The required information includes the rotor angle δ , the rotor speed $\Delta\omega$, electrical power P_e and the mechanical power P_m of all generators. The information comes from the online transient simulation of the interconnected power system and is updated at every time-step.

B. TIME-UPDATING GENERATOR GROUPS IDENTIFICATION

In this work, a time-updating method is proposed to identify the changing generator groups in the time-variable instability mode. The details are given as follows.

- (1). Sort the generators in ascending order by the generator angle of the moment t , $\delta_i(t)$;
- (2). Compute the angle difference $\delta_{ij}(t)$ between adjacent generators in sequence;
- (3). Choose the maximum angle difference as the boundary between two generator groups. The group with larger angles is the C -group, and the rest group is the N -group.

In the proposed method, generator groups are identified at each time-step of the online transient simulation, which is different from conventional generator grouping methods. The time-variable instability mode can thus be tracked by updating generator groups. Additionally, this method features small computation and high efficiency, which promotes its application to the large-scale interconnected power system.

C. REPRESENTATIVE GENERATORS SELECTION

The representative Generator selection step intends to choose these generators which are coherent and closely related to current instability mode. Thus, we propose a coherency index in (9).

$$\sigma_A(t) = \sqrt{\frac{1}{N_A} \sum_{i \in A} [\Delta\omega_i(t) - \Delta\omega_A(t)]^2}, \quad A = C \text{ or } N, \quad (9)$$

where $\Delta\omega_A(t) = \frac{\sum_{i \in A} M_i \Delta\omega_i(t)}{\sum_{i \in A} M_i}$ is the center speed and N_A is the number of generators in group A. In (9), the standard deviation of rotor speeds is used to depict the amount of dispersion of generators around the center in each group. A low σ_A indicates that the generators are close to the grouping center while a high σ_A indicates that the generators are of bad coherency.

The coherency index is further normalized in (10).

$$\sigma_{r,A}(t) = \left| \frac{\sigma_A(t)}{\Delta\omega_A(t)} \right|, \quad A = C \text{ or } N, \quad (10)$$

where $\sigma_{r,A}(t) \subseteq \mathbb{R}^+$. A larger value indicates worse coherency of the generator groups.

In what follows, two selection criterions are proposed to select the desired generators.

Criterion 1:

Enable condition: always.

$$\begin{aligned} \forall i \in C : & \text{ if } (1 - a)\bar{M}_C < M_i < (1 + b)\bar{M}_C, \quad \text{ then } i \in C_s. \\ \forall j \in N : & \text{ if } (1 - a)\bar{M}_N < M_j < (1 + b)\bar{M}_N, \quad \text{ then } j \in N_s. \end{aligned} \quad (11)$$

In (11), $\bar{M}_C = \sum_{i \in C} M_i / N_C$, $\bar{M}_N = \sum_{j \in N} M_j / N_N$ where N_C and N_N are the numbers of generators in group C and N separately. a and b are selection parameters. To ensure that selected generators are the main part (at least more than 50%) of whole generators, the value of a and b should refer to the range of all generators' inertia.

Criterion 2:

Enable condition: $\sigma_{r,A}(t) > \sigma_{r,set}$, $A = C$ or N

$$\begin{aligned} \text{In case of } \Delta\omega_C(t) > 0 : & \forall i \in C_s, \\ & \text{if } \Delta\omega_i(t) < 0, \quad \text{ then } i \notin C_s \\ \text{In case of } \Delta\omega_N(t) < 0 : & \forall j \in N_s, \\ & \text{if } \Delta\omega_j(t) > 0, \quad \text{ then } j \notin N_s \end{aligned} \quad (12)$$

where $\sigma_{r,set}$ is the coherency index threshold.

In criterion 1, the generator inertia constants are used to select the coherent generators because generators with close inertia have more possibilities to show similar oscillation period and better coherency. The selection results of criterion 1 are related to the generator groups and are updated when the instability mode changes.

Criterion 2 is applied to further generator selection in case of bad coherency. If the coherency index is larger than the threshold, criterion 2 is used to omit these generators which are not related to current instability mode from selected generators. For example, if $\Delta\omega_C(t) > 0$, the angles of major generators in C -group are increasing. Thus, these generators with decreased angles ($\Delta\omega_i(t) < 0$) should not be selected as the critical generators of moment t . The selection results of criterion 2 are updated when the instability mode changes or generators of moment t are of bad coherency.

D. ME-SMIB SYSTEM FORMATION AND INSTABILITY DETECTION

The ME-SMIB system is constructed by (7) with selected generators at each simulation step. It should be noted that any changes in selected generators groups (C_s and N_s), which may be caused by the changes in generator grouping or representative generators selection, will lead to the update of the ME-SMIB system. As a result, the phase trajectories of the ME-SMIB system are interrupted at moments that the ME-SMIB system is updated.

The concave-convexity based method is applied to detect the transient instability of the ME-SMIB system. In this method, if the phase trajectory becomes convex, the E-SMIB system will be unstable [14]. The instability index is computed as

$$c(t) = k(t) - k(t - \Delta t), \quad (13)$$

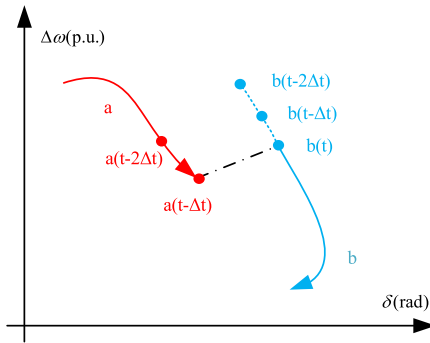

FIGURE 1. Calculation of instability index at discontinuous points of segmented phase trajectories.

where $k(t) = \frac{\Delta\omega(t) - \Delta\omega(t - \Delta t)}{\delta(t) - \delta(t - \Delta t)}$ is the slope of phase trajectory at moment t . The phase trajectory changes to convex if $c(t)$ becomes larger than 0. The transient instability of the ME-SMIB system can thus be detected by (14).

$$c(t) \geq 0 \tag{14}$$

To correctly obtain the instability index $c(t)$, one principle should be followed that the slopes of phase trajectory at two moments in (13), $k(t - \Delta t)$ and $k(t)$, should be calculated on one phase trajectory in the same ME-SMIB system. This principle is important for the method proposed in this paper because the ME-SMIB system may be updated during the transient process. For example, as shown in Figure 1, the ME-SMIB system is updated at moment t , and the phase trajectories are discontinuous between point $a(t - \Delta t)$ and $b(t)$. According to (13), the instability index at the previous moment, $c(t - \Delta t)$, is calculated by $c(t - \Delta t) = k_a(t - \Delta t) - k_a(t - 2\Delta t)$ on the phase trajectory a . But for the instability index at current moment t , $c(t)$, the correct calculation be $c(t) = k_b(t) - k_b(t - \Delta t)$ rather than $c(t) = k_b(t) - k_a(t - \Delta t)$. In other words, if the ME-SMIB system is updated at moment t , the slope of phase trajectory at the previous moment, $k(t - \Delta t)$, should be re-calculated on the new phase trajectory of the updated ME-SMIB system to obtain the correct instability index of the current moment.

If the instability criterion in (14) is satisfied, the power system is identified as unstable, and the pre-imagined disturbance is identified as harmful. Otherwise, the transient stability needs further determined with updated generator information of next time-step. If the transient simulation is terminated by pre-set end time (e.g., $T_{set} = 5s$) and no instability is detected, the system is identified as stable, and the pre-imagined disturbance is harmless. Figure 2 gives the outline of the ME-SMIB based online TSA method.

IV. CASES STUDY

To verify the validity of the proposed method, we study four scenarios in two multi-area interconnected power systems in this paper. A transient simulation software, PSD-BPA provide the required generator information in step 1 of Figure 2. The simulation time-step Δt is 0.01s. Parameters values are set as $a = 0.5$, $b = 1$ and $\sigma_{r,set} = 0.2$.

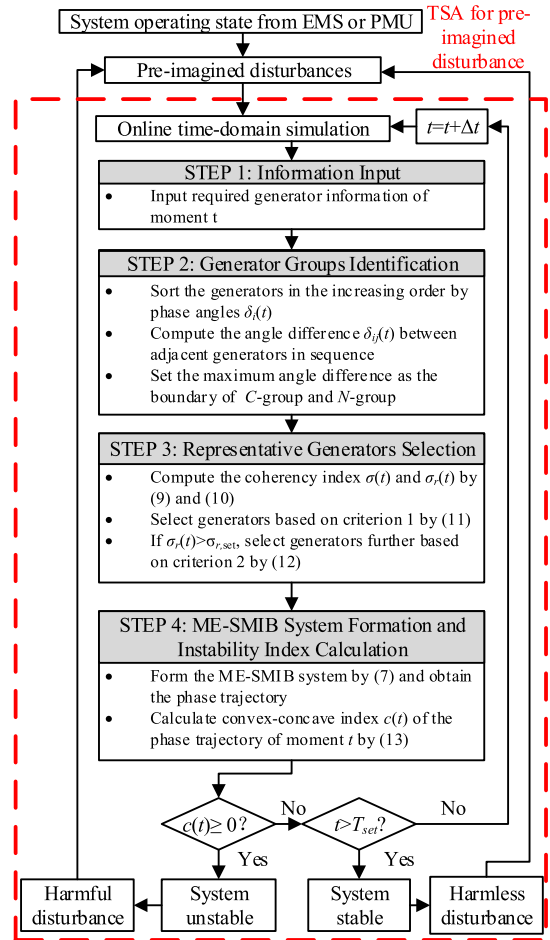

FIGURE 2. Outline of proposed ME-SMIB based online TSA method.

TABLE 1. Generator groups and selection results in case 1.

Scenario	Conventional E-SMIB		ME-SMIB	
	Group C Gen. No.	Group N Gen. No.	Group C _s Gen. No.	Group N _s Gen. No.
A	1-12	13-16	2-9	14-16
B	1-11	12-16	1-9	13-16

A. CASE1: 16-MACHINE 68-BUS POWER SYSTEM

The 5-area interconnected power system [30] is used to demonstrate the necessity of the ME-SMIB system especially when the system is in an untypical two-group instability mode. Following two scenarios are studied:

Scenario A: A three-phase short-circuit ground fault occurs in the middle of line 30-61 at 0s. Then the line is eliminated at 0.2s.

Scenario B: Same fault as Scenario A occurs at 0s and the fault line is eliminated at 0.25s.

The transient stability of the two scenarios is the opposite because of the different fault duration. Scenario A is stable while Scenario B is unstable. To compare the ME-SMIB system based on selected generators with the conventional E-SMIB system, we adopt the invariant generator groups in two scenarios, as listed in Table 1. Moreover, the generator selection criterion 2 is not enabled, and selected generators

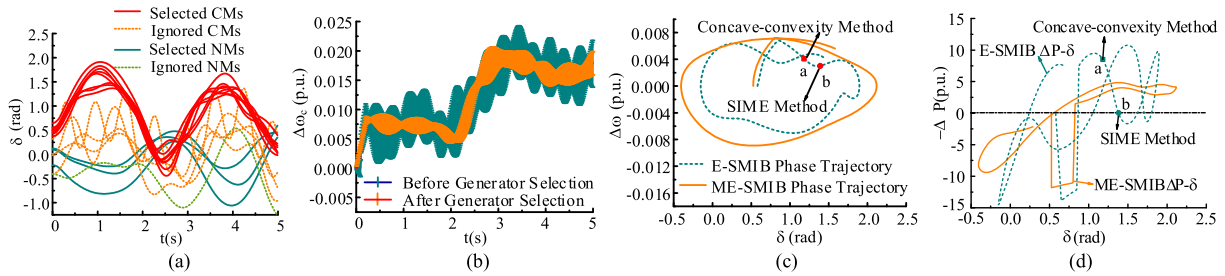

FIGURE 3. Comparison of the ME-SMIB system and conventional E-SMIB system in Case 1- Scenario A. (a) Generators angle curves, (b) Coherency indexes before and after generator selection, (c) Phase trajectory curves and (d) $\Delta P - \delta$ curves.

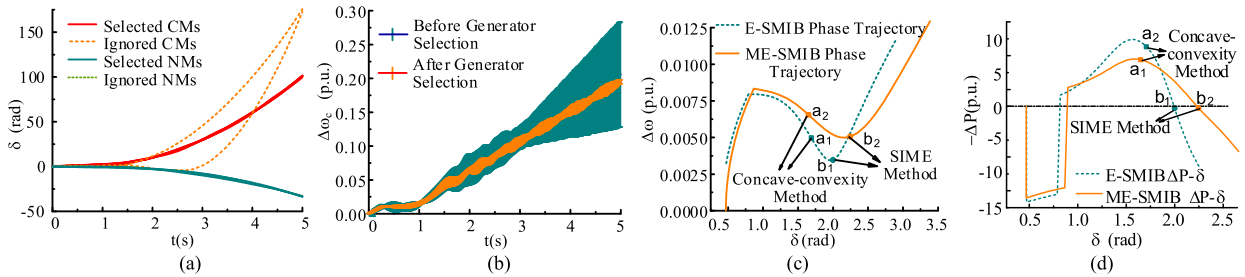

FIGURE 4. Comparison of the ME-SMIB system and conventional E-SMIB system in Case 1- Scenario B. (a) Generators angle curves, (b) Coherency indexes before and after generator selection, (c) Phase trajectory curves and (d) $\Delta P - \delta$ curves.

are also unchanged, as shown in Table 1. Therefore, the ME-SMIB system remains un-updated in two scenarios of case 1.

1) SCENARIO A

The generator’s angle curves in Figure 3 (a) indicates that system is in the untypical two-group instability mode in Scenario A. Generators are roughly separated into two groups and show apparent relative motion in each group. The original generator groups C and N thus are of bad coherency.

According to the generator selection criterions in (12), generators 2-9 and 14-16 are finally selected to construct the ME-SMIB system. The selected generators and ignored generators are distinguished by solid and dash lines in Figure 3 (a). It shows that the selected generators are coherent and can represent the instability mode of the system in Scenario A accurately.

Figure 3 (b) gives the comparison of coherency indexes before and after the generator selection. The figure is drawn in the form of error bands. The width of the band indicates the generator coherency. A narrow one means a better coherency of generators at this moment. It can be inferred that generators in the selected group C_s show much better coherency than those in the original group C .

Figure 3 (c) and (d) compare the phase trajectories and $\Delta P - \delta$ curves of the ME-SMIB system and conventional E-SMIB system, respectively. Figure 3 (d) indicates that the E-SMIB system has exceeded the UEP (point b), which is the symbol of transient instability in the ideal SMIB system. Thus, the system is identified as unstable according to the concave-convexity method at point a or SIME method at point b . However, the original system in Scenario A is proven to be stable in practice. This conflict mainly attributes to

the fact that the E-SMIB system’s time-variability changes the transient performance and makes it different from that of the ideal SMIB system. As discussed in section II, the time-variability of E-SMIB system are caused by the untypical two-group instability mode. In other words, the untypical two-group instability mode causes stability misjudgments in the conventional E-SMIB system.

The misjudgments are avoided in the proposed ME-SMIB system. The phase trajectory in Figure 3 (c) and $\Delta P - \delta$ curve in Figure 3 (d) correctly indicate the system is stable according to either SIME or concave-convexity based method. The $\Delta P - \delta$ curve of ME-SMIB system fits the description of an ideal SMIB system shown in (6). To conclude, the ME-SMIB system shows weaker time-variability and better similarity to the ideal SMIB system, which improves the accuracy of TSA.

2) SCENARIO B:

Figure 4 (a) gives the generator angles curves of scenario B. It shows the system is initially in a two-group instability mode and finally loses the synchronism in a three-group instability mode.

According to the generator selection criterions, generators 1-9 and 13-16 are selected finally to construct the ME-SMIB system. The coherency indexes before and after generator selection are compared in Figure 4 (b). It shows that the generator coherency is significantly improved after the generator selection, especially in the later stage.

The transient features of the ME-SMIB system and conventional E-SMIB system are compared in Figure 4 (c) and (d). Figures indicate that both the ME-SMIB system and the conventional E-SMIB system show unstable features. The phase trajectories in Figure 4 (c) and the curves of $\Delta P - \delta$ in Figure 4 (d) show that the system

TABLE 2. Transient stability detection results in case 1.

Scenario		A	B
Practical Stability		Stable	Unstable
Conventional E-SMIB System	SIME Method	Detected Stability	Unstable
		Detected Time	0.54s
	Concave-convexity based Method	Detected Stability	Unstable
		Detected Time	0.36s
ME-SMIB System	SIME Method	Detected Stability	Stable
		Detected Time	-
	Concave-convexity based Method	Detected Stability	Stable
		Detected Time	-

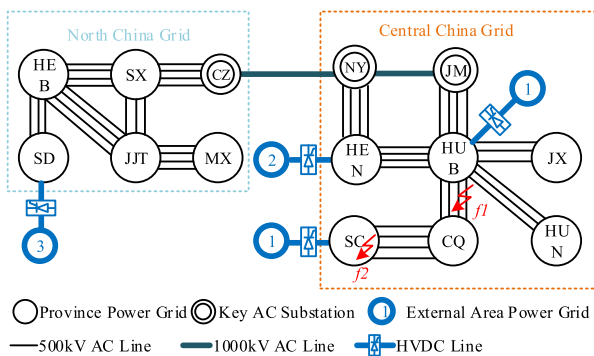
**FIGURE 5. Simplified diagram of Liang-Hua power system.**

exceeds the UEPs (at points). The instability detection points by SIME method are b_1 and b_2 , and these points by the concave-convexity method are a_1 and a_2 . Table 2 summarizes the transient stability detection results of two scenarios in case 1. The Comparisons show that:

- The ME-SMIB system can avoid stability misjudgments caused by the untypical two-group instability mode in stable scenarios (Scenario A);
- The ME-SMIB system correctly shows instability features in unstable scenarios (Scenario B) despite ignoring partial generators. These features can be detected even earlier by the ME-SMIB system.
- Compared with SIME method, the concave-convexity based method has the same accuracy but faster instability detection speed.

B. CASE2: CHINA PRACTICAL INTERCONNECTED POWER SYSTEM

The Liang-Hua power system, a reduced model of China practical interconnected power grid, is also studied to verify the applicability of the ME-SMIB based method. Figure 5 gives a simplified diagram of the Liang-Hua power system. It includes two main areas where 11 province sub-grids are involved. These sub-grids are connected by multiple HVAC (500kV and 1000kV) lines. Meanwhile, a large capacity of power transmission via HVDC lines from external-area

power grids are also included to simulate the actual system more accurately. The influence of DC parts on the AC power system angle transient stability can be ignored in this paper because we set that the DC part provides stable power transmission in the transient simulation. The total number of node buses is 12349, and the number of generators is more than 2000. High order models of generators and loads are adopted to simulate the transient response of the practical power grid. We test different faults including 2-phase/3 phase short-circuit faults on AC lines, transformer faults and bipolar blocking faults on DC lines in the test system. The proposed method can correctly identify the instability under different faults and avoid misjudgments in stable cases. Two typical scenarios are given below to show the validity of the proposed method.

1) SCENARIO A

A three-phase short-circuit ground fault ($f1$) occurs on the 500kV HVAC double transmission lines between CQ and HUB sub-grids at 0s. Then the double lines are eliminated at 0.2s. The angle curves of generators are given in Figure 6 (a). It shows the oscillation start from the interface among sub-grids and spread to the interface of the two-area interconnected power grids. Then the oscillation is damped, and the interconnected power system is eventually stable. In this scenario, the problems of time-variable instability mode and untypical two-group instability mode have occurred.

At each simulation step, generator groups are identified, and then representative generators are selected to construct the ME-SMIB system. Once the selected generator groups change, the ME-SMIB system will be updated, and the system develops from one period to the next. In scenario A, the ME-SMIB system is updated three times and forms four different periods, as shown in Figure 6 (a). The system develops from period 1 to 2 and from 3 to 4 because of the changes in the instability mode. The time-variable instability mode is thus correctly tracked by the real-time generator grouping method. The system develops from period 2 to period 3 because different generators are selected according to the selection criterion 2. Generators which are not related to current instability mode are ignored (e.g., in period 2) to handle the untypical two-group instability mode.

Figure 6 (b) and (c) give the phase trajectories and instability index curves of the ME-SMIB system. Figures show that the phase trajectories are always concave in the ME-SMIB system and the instability index curves are always under 0 in different periods, indicating that the power system is transient stable. Therefore, the ME-SMIB method correctly evaluates the transient stability of the interconnected power system despite the time-variable and untypical two-group instability mode.

By contrast, the conventional E-SMIB system is constructed by all generators in the way of unchanged generator groups. When the instability mode changes, e.g., from period 1 to 2, the unchanged generator groups cause a severe problem of generator coherency, which leads to the strong

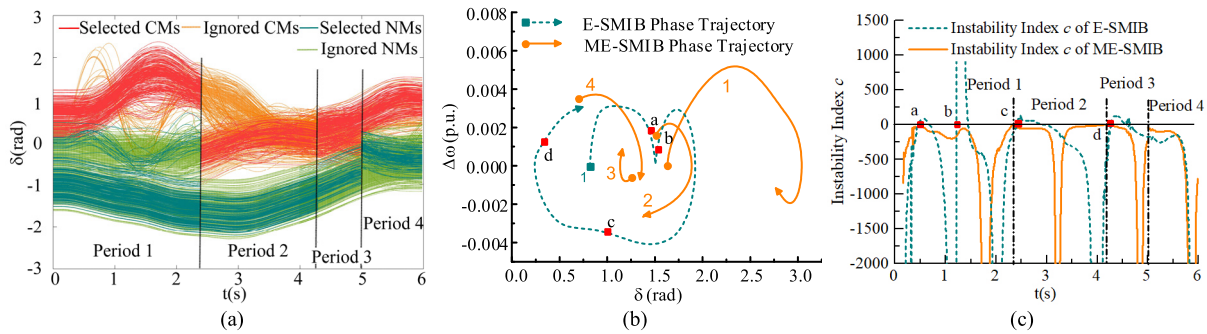

FIGURE 6. Application of ME-SMIB based method to the interconnected power system (Case 2- Scenario A). (a) Generator groups identification and selection result, (b) Phase trajectory curves and (c) Instability index curves.

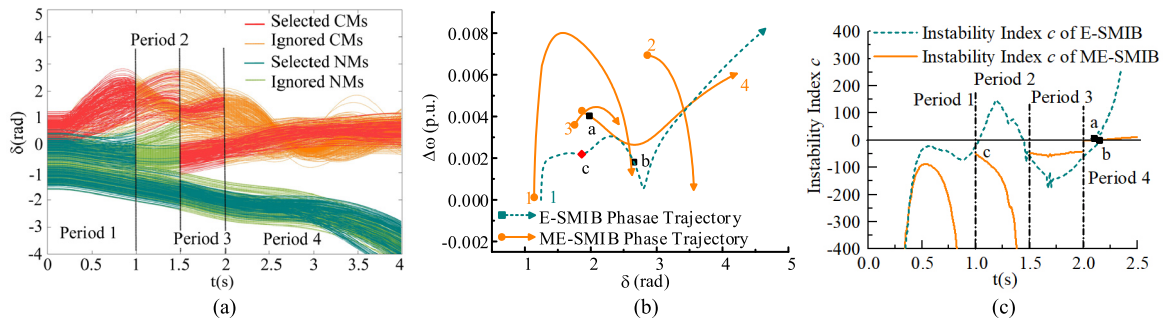

FIGURE 7. Application of ME-SMIB based method to the interconnected power system (Case 2- Scenario B). (a) Generator groups identification and selection result, (b) Phase trajectory curves and (c) Instability index curves.

time-variability of the E-SMIB system. As a result, the E-SMIB system shows different transient stability features from the ideal SMIB system. The phase trajectory of the conventional E-SMIB system in Figure 6 (b) indicates the system exceed the UEP even though the original interconnected power system is stable. The stability misjudgments are made four times (at points a, b, c and d) based on the instability index curve of the E-SMIB system in Figure 6 (c).

2) SCENARIO B

A three-phase short-circuit ground fault (f2) occurs on the 220kV AC double transmission lines inside the SC sub-grid at 0s. Then the double lines are eliminated at 0.12s. The angle curves in Figure 7 (a) shows the oscillation develops from the SC sub-grid inside to the interface of sub-grids, and then spreads to the interface of the two-area power grids, which finally results in the out-of-step of the power system. In this scenario, both time-variable instability mode and the untypical two-group instability mode occur.

Figure 7 (a) gives the results of generator grouping and generator selection. The ME-SMIB system is updated three times, resulting in four different periods. The system develops from period 1 to 2 and from 2 to 3 because of the changes in the instability mode. Then it develops from period 3 to 4 because different generators are selected according to the selection criterion 2. Figure 7(b) and (c) give the segmented phase trajectories and instability curves of the ME-SMIB system. The trajectory becomes convex, and the instability index becomes larger than 0 at point a in period 4, indicating the system is unstable. The transient instability

is thus detected by the ME-SMIB method at 2.1s. As a contrast, the instability is detected at 2.14s (point b) by the conventional E-SMIB method. It is noted that the instability index of the E-SMIB system indicates the system is unstable at 1.05s (point c). We tend to classify it as a misjudgment because the generator angles are close to each other at that moment and the instability mode of 1.05s is different from the final instability mode.

V. CONCLUSION

In this paper, an ME-SMIB based method is proposed for the online TSA of the multi-area interconnected power system. The contributions of this work are concluded as:

- (i.) In this paper, the impacts of the multi-area grid structure on the transient stability of the interconnected power system are analyzed and then summarized as the time-variable instability mode and untypical two-group instability mode.
- (ii.) The problem of time-variable instability mode is addressed by a time-updating generator grouping scheme. The scheme can track the changes of instability mode by updating generator groups at each time-step.
- (iii.) The problem of untypical two-group instability mode is addressed by selecting representative generators to construct the ME-SMIB system. Generators are selected on the principle of coherency and majority.
- (iv.) Cases verification in two test systems shows that proposed ME-SMIB system can avoid the stability misjudgments and ensure the rapidity of

instability detection, featuring superior reliability to the conventional E-SMIB system. The proposed method shows good applicability in complicated scenarios of the multi-area interconnected power system.

In this work, the influence of DC parts on the TSA of the interconnected power system is not considered. Thus, one possibility of future exploration would be the evaluation and control of angle transient stability in the AC/DC hybrid power system considering DC transients. Besides, this work also has a prospect of real-time application with the aid of Phase Measurement Units (PMUs) because all the required generator information can be accessed online from the PMUs.

REFERENCES

- [1] M. A. Tomim, J. R. Marti, and J. A. P. Filho, "Parallel transient stability simulation based on multi-area Thévenin equivalents," *IEEE Trans. Smart Grid*, vol. 8, no. 3, pp. 1366–1377, May 2017.
- [2] J. Verselle and K. Staschus, "The mesh-up: ENTSO-E and European TSO cooperation in operations, planning, and R&D," *IEEE Power Energy Mag.*, vol. 13, no. 1, pp. 20–29, Jan. 2015.
- [3] C. Wang, K. Yuan, P. Li, B. Jiao, and G. Song, "A projective integration method for transient stability assessment of power systems with a high penetration of distributed generation," *IEEE Trans. Smart Grid*, vol. 9, no. 1, pp. 386–395, Jan. 2018.
- [4] P. Pourbeik, P. S. Kundur, and C. W. Taylor, "The anatomy of a power grid blackout-Root causes and dynamics of recent major blackouts," *IEEE Power Energy Mag.*, vol. 4, no. 5, pp. 22–29, Sep. 2006.
- [5] C. Xu and A. Abur, "A fast and robust linear state estimator for very large scale interconnected power grids," *IEEE Trans. Smart Grid*, vol. 9, no. 5, pp. 4975–4982, Sep. 2018.
- [6] V. Jalili-Marandi, Z. Zhou, and V. Dinavahi, "Large-scale transient stability simulation of electrical power systems on parallel GPUs," *IEEE Trans. Parallel Distrib. Syst.*, vol. 23, no. 7, pp. 1255–1266, Jul. 2012.
- [7] M. A. Tomim, T. De Rybel, and J. R. Marti, "Extending the multi-area Thévenin equivalents method for parallel solutions of bulk power systems," *Int. J. Elect. Power Energy Syst.*, vol. 44, no. 1, pp. 192–201, 2013.
- [8] C. M. C. Arvizu and A. R. Messina, "Dimensionality reduction in transient simulations: A diffusion maps approach," *IEEE Trans. Power Del.*, vol. 31, no. 5, pp. 2379–2389, Oct. 2016.
- [9] S. Wang, S. Lu, N. Zhou, G. Lin, M. Elizondo, and M. A. Pai, "Dynamic-feature extraction, attribution, and reconstruction (DEAR) method for power system model reduction," *IEEE Trans. Power Syst.*, vol. 29, no. 5, pp. 2049–2059, Sep. 2014.
- [10] H. Dong et al., "Reduction and modelling method of large-scale alternating current/direct current power systems for electromagnetic transient simulation," *IET Gener., Transmiss. Distrib.*, vol. 8, no. 10, pp. 1667–1676, Oct. 2014.
- [11] P. Bhui and N. Senroy, "Real-time prediction and control of transient stability using transient energy function," *IEEE Trans. Power Syst.*, vol. 32, no. 2, pp. 923–934, Mar. 2017.
- [12] S. Dasgupta, M. Paramasivam, U. Vaidya, and V. Ajarapu, "PMU-based model-free approach for real-time rotor angle monitoring," *IEEE Trans. Power Syst.*, vol. 30, no. 5, pp. 2818–2819, Sep. 2015.
- [13] J. C. Cepeda, J. L. Rueda, D. G. Colomé, and D. E. Echeverría, "Real-time transient stability assessment based on centre-of-inertia estimation from phasor measurement unit records," *IET Gener., Transm. Distrib.*, vol. 8, no. 8, pp. 1363–1376, 2014.
- [14] B. Zhang, S. Yang, and H. Wang, "Closed-loop control of power system transient stability(1): Transient instability detection principle of simple power system," *Electr. Power Autom. Equip.*, vol. 34, no. 8, pp. 1–6, Aug. 2014.
- [15] S. Zhao, H. Jia, and D. Fang, "Partition-composition method for online detection of interconnected power system transient stability," *IET Gener., Transmiss. Distrib.*, vol. 10, no. 14, pp. 3529–3538, 2016.
- [16] Y. Xu, Z. Yang, J. Zhang, Z. Fei, and W. Liu, "Real-Time Compressive Sensing based Control Strategy for a Multi-area Power System," *IEEE Trans. Smart Grid*, vol. 9, no. 5, pp. 4293–4302, Sep. 2018.
- [17] D. Wu, C. Lin, V. Perumalla, and J. N. Jiang, "Impact of grid structure on dynamics of interconnected generators," *IEEE Trans. Power Syst.*, vol. 29, no. 5, pp. 2329–2337, Sep. 2014.
- [18] S. R. Islam, D. Sutanto, and K. M. Muttaqi, "A distributed multi-agent based emergency control approach following catastrophic disturbances in interconnected power systems," *IEEE Trans. Power Syst.*, vol. 31, no. 4, pp. 2764–2775, Jul. 2016.
- [19] S. Bakshi, A. Velayutham, and S. C. Srivastava, "Report of the enquiry committee on grid disturbance in northern region on 30th July 2012 and in Northern, Eastern & North-Eastern Region on 31st July 2012," Enquiry Committee, New Delhi, India, Tech. Rep. Rep_16_8_12, 2012. [Online]. Available: https://powermin.nic.in/sites/default/files/uploads/GRID_ENQ_REP_16_8_12.pdf
- [20] B. Wang, B. Fang, Y. Wang, H. Liu, and Y. Liu, "Power system transient stability assessment based on big data and the core vector machine," *IEEE Trans. Smart Grid*, vol. 7, no. 5, pp. 2561–2570, Sep. 2016.
- [21] K. Sun, S. Likhate, V. Vittal, V. S. Kolluri, and S. Mandal, "An online dynamic security assessment scheme using phasor measurements and decision trees," *IEEE Trans. Power Syst.*, vol. 22, no. 4, pp. 1935–1943, Nov. 2007.
- [22] R. Zhang, Y. Xu, Z. Y. Dong, and K. P. Wong, "Post-disturbance transient stability assessment of power systems by a self-adaptive intelligent system," *IET Generation, Transmiss. Distribution*, vol. 9, no. 3, pp. 296–305, 2015.
- [23] J. Lv, M. Pawlak, and U. D. Annakkage, "Prediction of the transient stability boundary using the lasso," *IEEE Trans. Power Syst.*, vol. 28, no. 1, pp. 281–288, Feb. 2013.
- [24] T. L. Vu and K. Turitsyn, "Lyapunov functions family approach to transient stability assessment," *IEEE Trans. Power Syst.*, vol. 31, no. 2, pp. 1269–1277, Mar. 2016.
- [25] A. Shamisa and M. Karrari, "Model free graphical index for transient stability limit based on on-line single machine equivalent system identification," *IET Gener., Transmiss. Distrib.*, vol. 11, no. 2, pp. 314–321, 2017.
- [26] M. Pavella, D. Ernst, and D. Ruiz-Vega, *Transient Stability of Power Systems: A Unified Approach to Assessment and Control*. Norwell, MA, USA: Kluwer, 2010.
- [27] M. Yin, C. Y. Chung, K. P. Wong, Y. Xue, and Y. Zou, "An improved iterative method for assessment of multi-swing transient stability limit," *IEEE Trans. Power Syst.*, vol. 26, no. 4, pp. 2023–2030, Nov. 2011.
- [28] W. Yu, Y. Xue, J. Luo, M. Ni, H. Tong, and T. Huang, "An UHV grid security and stability defense system: Considering the risk of power system communication," *IEEE Trans. Smart Grid*, vol. 7, no. 1, pp. 491–500, Jan. 2016.
- [29] B. Zhang, S. Yang, H. Wang, S. Ma, and L. Wu, "Closed-loop control of power system transient stability (2): Transient instability detection method of multi-machine power system," *Electr. Power Automat. Equip.*, vol. 34 no. 9, pp. 1–6, Sep. 2014, doi: 10.3969/j.issn.1006-6047.2014.09.001.
- [30] *IEEE 39 Bus Power System Model*. Accessed: Mar. 1, 2018. [Online]. Available: <http://www.sel.eesc.usp.br/ieee/>



SONGHAO YANG (S'18) was born in Laiwu, Shandong, China, in 1989. He received the B.S. degree in electrical engineering from Xi'an Jiaotong University, Xi'an, China, in 2012. He is currently pursuing the Ph.D. degree in electrical engineering with Xi'an Jiaotong University and Tokushima University.

His research interests are power system transient stability assessment and control.



BAOHUI ZHANG (SM'99) was born in Wei Country, Hebei, China, in 1953. He received the M.S. and Ph.D. degrees in electrical engineering from Xi'an Jiaotong University, Xi'an, China, in 1982 and 1988, respectively.

He has been a Professor with the Electrical Engineering Department, Xi'an Jiaotong University, since 1992. His research interests are power system analysis, control, communication, and protection.



MASAHIDE HOJO (S'98–M'99) was born Tokushima, Japan. He received the M.S. degree in engineering from Kobe University in 1996, and the Ph.D. degree in engineering from Osaka University in 1999.

He is currently a Professor at Tokushima University. His research interests are the advanced power system control by power electronics technologies, and analysis of power systems.

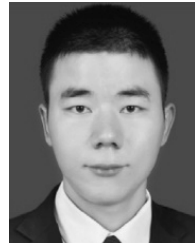

FU SU was born in Chongqing, China, in 1992. He received the B.S. and M.S. degrees in electrical engineering from Xi'an Jiaotong University, Xi'an, China, in 2014 and 2017, respectively. He is currently with the State Grid Sichuan Electric Power Dispatching Control Center, Sichuan, China.

...