

Received May 11, 2018, accepted June 14, 2018, date of publication June 21, 2018, date of current version July 25, 2018.

Digital Object Identifier 10.1109/ACCESS.2018.2849572

CERNTAURO: A Modular Architecture for Robotic Inspection and Telemanipulation in Harsh and Semi-Structured Environments

MARIO DI CASTRO^{1,2}, MANUEL FERRE², (Member, IEEE), AND ALESSANDRO MASI¹

¹European Organization for Nuclear Research, CERN, 1211 Geneva, Switzerland

²Centro de Automática y Robótica-CAR UPM-CSIC, Universidad Politécnica de Madrid, 28006 Madrid, Spain

Corresponding author: Mario Di Castro (mario.di.castro@cern.ch)

ABSTRACT Intelligent robotic systems are becoming essential for industries, nuclear plants, and for harsh environments in general, such as the European Organization for Nuclear Research (CERN) particles accelerator complex and experiments. In order to increase safety and machine availability, robots can perform repetitive, unplanned, and dangerous tasks, which humans either prefer to avoid or are unable to carry out due to hazards, size constraints, or the extreme environments in which they take place. A novel robotic framework for autonomous inspections and supervised teleoperations in harsh environments is presented. The proposed framework covers all aspects of a robotic intervention, from the specification and operator training, the choice of the robot and its material in accordance with possible radiological contamination risks, to the realization of the intervention, including procedures and recovery scenarios. The robotic solution proposed in this paper is able to navigate autonomously, inspecting unknown environments in a safe way. A new real-time control system was implemented in order to guarantee a fast response to environmental changes and adaptation to different type of scenarios the robot may find in a semi-structured and hazardous environment. Components of the presented framework are: a novel bilateral master-slave control, a new robotic platform named CERNbot, and an advanced user-friendly multimodal human-robot interface, also used for the operators' offline training, allowing technicians not expert in robot operation to perform inspection/maintenance tasks. The proposed system has been tested and validated with real robotic interventions in the CERN hazardous particle accelerator complex.

INDEX TERMS Mobile robots, robot control, robot learning, robot sensing systems, robot vision system, telerobotics, human-robot interaction, intelligent systems, Internet of Things.

I. INTRODUCTION

The revolution of Industry 4.0 involves a modern manufacturing style, known as Intelligent Manufacturing [1], which focuses on customized production and massive customization instead of the classic massive production. A key component of Industry 4.0 is the global industrial movement named Internet of Things (IoT) [2], [3], which changed the way a wide range of industries approach the procurement, processing, and distribution of raw materials and finished products.

The production in capital-intensive industries has created needs for robustness, dexterity, and cost efficiency, especially in the field of automation and robotics. Nuclear plants like Fukushima [4], power plants like ITER [5], as well as particle accelerator facilities [6], such as the European Organization for Nuclear Research (CERN) [7], The European X-ray

free-electron laser (XFEL) [8], or FERMILAB [9], present harsh environments, several kilometers of underground and semi-structured accelerator areas with thousands of different items of equipment which need to be inspected and maintained. Due to the presence of human hazards mainly produced by radiation and high magnetic fields, the plants and accelerators need to be inspected and maintained remotely, possibly using robots. Power plants and semi-structured particle accelerator environments present different constraints like accessibility, long distances, objects with various pose and occlusion in cluttered areas.

In addition, the machine's equipment are delicate and expensive and in most cases, the equipment owners and/or machine experts need to operate the robots for the remote maintenance. This aspect requires a robotic system with

a user-friendly human-machine interface, possibly equipped with haptic devices that allow the operator long operation without too much stress.

Industrial robots today are mainly assigned to repetitive and grunt work without much flexibility or even intelligence and they are not adapted to harsh and semi-structured environments. The gap between requirement and reality introduces industrial-level mobile manipulation robotic technology featured with task flexibility, robotic mobility and learning ability [10]. However, these solutions are environment specific and cannot be seamlessly adapted to different kinds of environment without a non-negligible cost in terms of hardware and software alterations. Operating robots for maintenance in dangerous environments on costly machines requires skilled and well trained, dedicated shift operators [11]. This is costly, highly time-consuming and is mainly due to the non-intuitive human robot interfaces present on industrial robot mobile manipulators. In specific remote tasks such as brazing or milling, expert technicians are unable to operate robots due to lack of teleoperation experience. Thus, a user-friendly human robot interface is required that increases the process transparency [12], reduces the operator's fatigue and does not require a pool of well-trained robotic operators which, in some cases, are dedicated to a specific robotic task.

Another crucial aspect to take into account for environments where a quick robotic intervention is needed to increase the machine uptime and reduce the operational cost, is the ability to mitigate incidents during robotic operations. For example, the robot must be able to recover an object lying on the ground or a tool, which may accidentally fall, an aspect that is not present in many of the industrial solutions. It also has to be able to be recovered by another robot or machine in case of failure. Taking into account these aspects, the robot must be lightweight and recoverable by another robot or turned off remotely in a safe way.

Moreover, in environments where radiological contamination is a risk, the materials of which the robots are composed of are fundamental to avoid radiological contamination and unwanted radiological waste with the risk that an expensive robot might become impossible to be used again. Regarding the design of robots for hazardous environments, some specific requirements are needed, such as waterproof mechanical components, security skeleton, wheels adapted to the environment, and lifting system, in order to enhance the efficiency of the mobile manipulator. This allows further use of a robot after an intervention, enabling the robot to be easily cleaned [13]. Expensive machines in hazardous and semi-structured environments in general present maintenance and dismantling challenges, which require a mobile manipulator system with vision, intelligence, and automation, which is not currently available as an industrial solution.

This work presents a novel robotic framework for autonomous inspection and supervised teleoperations in semi-structured and harsh environments. The framework covers all the aspects of a robotic intervention, from the

low-level control, the requirements analysis and the intervention simulation to the on-the-field operation including procedures, tools and recovery scenarios. The following section presents the state of the art in mobile manipulators, while Section III presents the problem formulation. In Section IV, the new proposed solution is described in detail. Section V focuses on the validation work. Finally, the paper will end with conclusions and outlooks.

II. STATE OF THE ART

In the last decades, robot developments have been through several steps of evolution (see Table 1) [14]. Mobile manipulators are robotic systems consisting of one or more robot arms mounted on a mobile platform, which allows the system to perform tasks with locomotion and manipulation abilities. Remotely operated systems allow human beings to work effectively from a safe place. Applications of such robotic systems in hazardous and semi-structured environments cover a wide range of scenarios such as underwater, where remotely operated vehicles (ROVs) [15] and autonomous vehicles (AUVs) [16]–[19] are mostly used by oil and gas industries for inspection and installation tasks [20]–[22]. Various other applications can be found in aerial fields [23], [24]. These include robotic solutions for observation [25], military operations [26]–[29], civilian and private applications [30] and payload delivery in the space field, for open space manipulation and robotic exploration vehicles [31]–[35], in mining fields [36], [37], military fields [38], [39], such as landmine eradication or bomb detonation [40], [41], as well as in nuclear and radioactive fields [42], [43].

TABLE 1. Robotic revolution for past and future years.

Robotic revolution	YEAR	Type
1.0	1970	Industrial robots
2.0	1980	Service robots
3.0	2000	Personal robots
4.0	2010	Connected robots (IoT)/ Industry 4.0
5.0	2020	Intelligent robots
6.0	2030	Singularity robots / Self-sufficient robots

Particularly for the radioactive field, the first remote handling was developed in the 1940s when the discoveries in atomic physics led to the possibility of exploring the nature of the materials associated with ionizing radiation in more detail. The first system developed was a mechanical-master-slave manipulator performing kinaesthetic and tactile feedback [44]. The mechanical coupling between the master and the slave device constituted a non-negligible problem considering that the two devices were separated by a distance of about 10 meters. This problem was largely overtaken during the late 1960s and the early 1970s, when the advent of

new technologies in electronics and computing led to the physical separation of the master and the slave, developing the first electrical master-slave manipulator [45]. During this period, research and innovation in the field of the telemanipulation defined the control system hierarchies and structures in tele robotics [46], producing several industrial products for the following years. From the 1980s onward, the development of mobile manipulators has gone through several stages, concentrating on different key components in both hardware and software. During that period, many mobile manipulators have been developed, of which MORO [47], Rob@Work [48], Little Helper [49], PR2 [50], TUM Rosie [51], KUKA OmniRob and KMR iiwa are the most representative mobile manipulators (Figure 1).



FIGURE 1. Kuka Omnirob mobile manipulator.

Robust military vehicles were built in the last decades [52], satisfying the demands of de-mining and bomb disposal, but lacking the scalability and the possibility to integrate custom control and artificial intelligence which are both mandatory in intelligent robotic systems.

Unlike the many types of industrial robots deployed in industrial environments [53], robots ready to be used in semi-structured and hazardous environments are not abundant and in general, they are built for specific needs. In recent years, significant progress has been made in advancing the state-of-the-art in the same way as mobile manipulators.

Technologies such as vision-based navigation [54], teleoperation [55]–[57] and collision free motion planning for telemanipulation are widely studied and applied on robotic platforms with satisfactory results. Several European projects include robust mobility and dexterous manipulation, such as FirstMM [58], TAPAS [59], and VALERI [60], for which the results reveal that research in mobile manipulation follows the logical integration of navigation, perception, teleoperation, manipulation and learning.

III. PROBLEM FORMULATION

Although important progress was made in the field, there is still much work left in the application of mobile manipulation in harsh and semi-structured environments. In the following, examples of robotic missions needed at CERN are listed:

1. Autonomous inspection of semi-structured tunnels
2. Nondestructive testing inspections

3. Safe use of robots in confined spaces
4. In-situ maintenance and repair using teleoperation
5. Personnel escort and health monitoring

These five examples provide a reasonably diverse overview motivating the development of customized robotic controls and systems. Challenges include the need for software flexibility, modularity and safety. Furthermore, the complication of the process of teaching a robot and programming its features, demonstrate how much work is left as well as adapting the developed solution for different needs. TABLE 2 summarizes the most common harsh environment challenges and the main CERNTAURO control features to tackle these challenges, including the possibility to control the robot via SMS using GSM-operated remote control systems.

TABLE 2. Harsh environments challenges.

Challenge	CENTAURO control feature
Limited intervention time in very long distances	Variable speeds according to the time needs. Passivation of unused on-board sensors and devices
Unexpected Obstacles	Autonomous navigation and obstacle avoidance
Environmental hazards (e.g. radiation)	Augmented reality navigation using virtual obstacles
Precision localization during environmental measurement	Precise on board odometry using modular sensor fusion according to real time measurements
Delicate equipment and safety	Anti-collision and fail-safe system, recovery scenarios
Poor communication signal, time fluctuations	Time delay passivation, control through SMS, notifications/alerts via SMS

IV. THE CENTAURO FRAMEWORK

The introduction, state of the art and problem formulation exposed in the previous chapters contributes to the necessity of developing a brand-new user-friendly robotic solution, modular and adaptable to the different robots and different scenarios presented in the harsh and semi-structured environments, like the CERN accelerator complexes or nuclear facilities. In Figure 2, the overall architecture of the CERNTAURO framework is presented. A virtual private network (VPN) using PTP connection with CHAP encryption has been implemented for communication safety. The proposed novel robotic framework allows single or cooperative operators to control different robots with using the same human-robot-interface and gives the possibility to perform tasks using multiple collaborative robots (Figure 3).

The proposed novel framework is applied following 3 main pillars, each of them consisting of different modules presented in the following paragraphs.

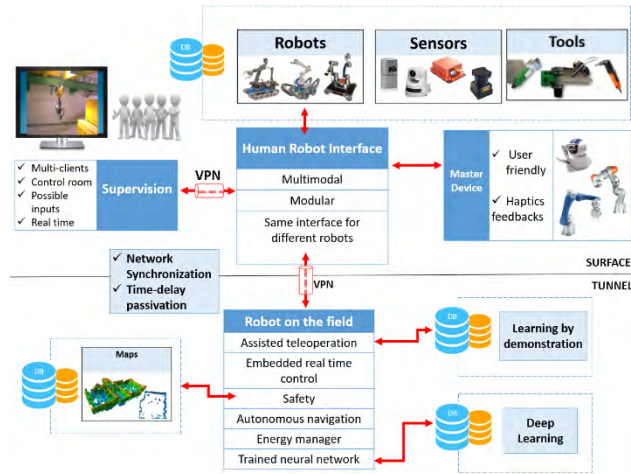

FIGURE 2. Overall architecture of the CERNTAURO framework.

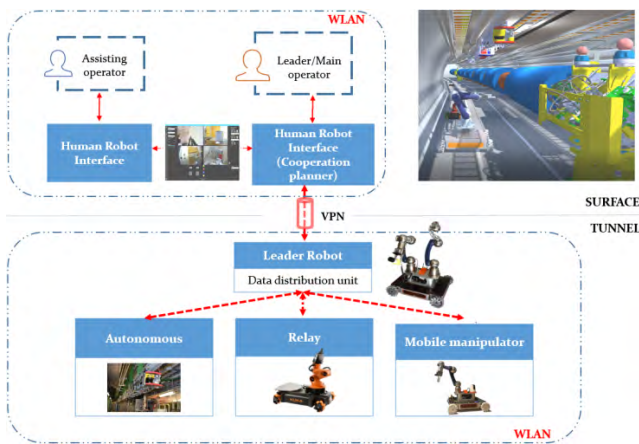

FIGURE 3. CERNTAURO Architecture for Cooperative Multirobot Interventions. Simulation in virtual reality of collaborative robots running CERNTAURO framework (top-right).

A. INTERVENTION PREPARATION AND DEBRIEFING

The intervention preparation of the CERNTAURO framework requires a series of modules that are listed below.

1) FUNCTIONAL REQUIREMENTS

The first vital step for a successful robot operation is the full acknowledgement of functional intervention requirements. Distinguishing between a machine-required task and its capabilities in reality is not an obvious task. The proposed CERNTAURO framework can be integrated into different robots (see Section V) and this feature has driven the design of the Functional Requirements Module (FRM). The FRM module is an automatic decision tree algorithm that helps the intervention preparation suggesting the choice of the robot from functional requirements like type of requested task, payload, compliancy, dexterity, hazards, intervention time and so on. The FRM takes information of the existing mechatronics and tooling possibilities from the robots and tooling pools where the most important features of each device and tools are listed and analyzed according to the

priority for different tasks (TABLE 3 and TABLE 4). The modules then automatically suggest the robots and the tools to use (Figure 4). The FRM also provides the possibility to combine different robotic components. For instance, integrating different robotic arms on different UGVs or in the case of relay robots needs, it can suggest the use of different robots as Wi-Fi relays to extend the communication coverage [61]. On the database of the robotic pools, the entire features of each robot are listed, but the proposed automatic module can dynamically configure types of robots and tool suggestions mixing the basic ones with different properties.

TABLE 3. A reduced example of a database fixed table of the CERNTAURO robotic pool.

Robot name	Payload [kg]	Angular max speed [rad/s]	Linear velocity [m/s]	Dexterity [from A to F]
A	5	15	0	B
B	7	40	1.5	C
C	50	5	2	E

TABLE 4. A reduced example of a database table of the CERNTAURO tooling pool.

Tool name	Torque [Nm]	Angular max speed [rad/s]	Linear velocity [m/s]	Dexterity [from A to F]
A	24	15	0	B
B	4	40	1.5	C
C	5	5	2	E

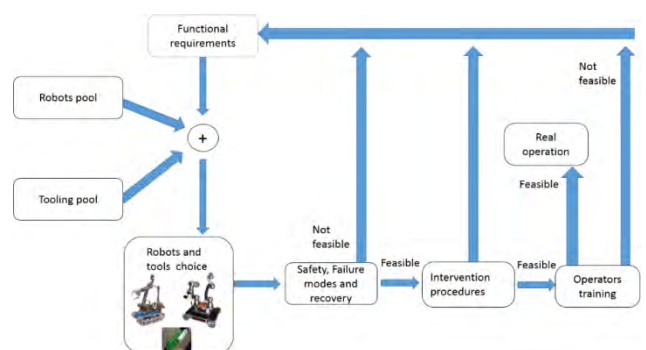

FIGURE 4. Pipeline scheme of a CERNTAURO robotic intervention.

As an example, if a fine grasping and manipulation is needed, the FRM will most likely suggest using Robot B (high dexterity required) with Tool C, while it would choose Robot C with Tool A if a high payload was needed. The module can also indicate if a robot and/or a tool that can fulfill the demanded tasks are not present in the robotic pool, leading then to the design or modification of new robots and tools.

2) FAILURE MODES AND RECOVERY SCENARIOS

Once the framework suggests the appropriate robot to use for a requested remote intervention, the functional requirements' designs are conducted through a safety aspect implementation, including failure mode identifications using clustering analysis and recovery scenario procedures. These two fundamental steps are strictly iterative during the first phase of an intervention preparation: safety or recovery scenario procedures can influence, and in some cases, adjust the requirements because of technological limitations. Machine and human safety aspects need to be taken into consideration, for example the risk of radioactive environments or places with a high magnetic field presence that can negatively influence the normal operational behavior of mechatronic systems.

3) BEST PRACTICE, PROCEDURES PREPARATION AND TRAINING

For the intervention preparation, the CERNTAURO framework has been equipped with the Virtual Environment for intelligent Robotic Operations (VERO) modules which takes in input of all relevant CAD models and drawings. From this data, a virtual environment for simulation is created using Unity [62], [63] as a framework for virtual environment simulation. This module is fundamental for the design of the robotic procedures, tools and recovery scenarios that are vital in harsh and hazardous environments.

According to the tasks and missions requested, a training program for the robot and the operators has to be set up. Part of the CERNTAURO framework is the Robot Operator Training (ROOT) module which, according to the difficulty of the mission and the dexterity demanded, suggests the type of training and learning, the operators and the robots must undertake.

During the offline training, time and operator stress are monitored. One of the main requirements during the development of this system was to create an environment which is usable for different types of operators. Therefore a classification of the operators was done and different categories of operators were defined [64] according with their robotic operation skills. The development of the system then took into account these categories, resulting in a system that is usable and learnable for entry-level operators but also provides all the advanced features required by an expert operator. From the low-level robot control to the Human-Robot Interface, the entire development was done in such a way as to provide a complete and involving experience to any type of operator.

A robotic simulator framework using Unity and Gazebo [65] was created. In this simulator, the entire robot pool in all its configurations is integrated, not only in its mechanical aspects, but also in its control and sensor systems, including cameras. In this simulator, it is then possible to include the intervention area model, which is obtained by integrating CAD drawings or real 3D reconstructions obtained from previous inspections of the same area by the use of RGB-D cameras or pictures used in a Structure from

Motion pipeline [66]. This model contains all the details of the real environment (including cable positions, unexpected objects, etc.). The simulator provides an interface, which allows an operator to control any robot through the multi-modal Human-Robot Interface. Consequently, the operator will train using exactly the same interface which will be used during the real intervention, providing a more accurate experience during the training phase. During the training period, intervention procedures are established by following best practices in remote handling, as well as the definition of the need in terms of tools and recovery scenarios in case of accidents.

After each intervention, the robots are checked for possible radiological contamination following procedures included in the proposed framework [67]. The robots of the CERNTAURO pool are modified to be air-tight avoiding contaminated dust to enter inside them minimizing contaminated waste [68]. In addition, the materials of the robots are chosen to minimize the robots radiological activation [69], [70]. The CERNTAURO framework includes a debriefing template document to be filled by the operators and the clients and its goal is to analyze eventual problems or matters which can be improved for future robotic tasks. This preventive work for future robotic tasks is fundamental in places where robotic services are needed.

B. CONTROL SYSTEM AND ARTIFICIAL INTELLIGENCE

Based on a core-periphery model [71], the Central Operating System (COS) proposed in the novel CERNTAURO framework was developed using C++ and it is interfaced with the different mechatronic parts of a robotic system (Figure 5). The framework is based on several modules with a deterministic loop time allowing their combination to be real time compatible.



FIGURE 5. COS core-periphery model.

The control architecture of the proposed framework is designed to be modular and fail-safe. In a semi-structured and hazardous environment, normally the communication link between the operator and the robot is not reliable as it is based on 3G/4G/WiFi and on standard internet protocols (TCP, UDP). Therefore, to guarantee safety and autonomy,

the entire control loop should be closed on the on-board robot control system.

The CERNTAURO systems implement two types of control:

- a. Supervisory control, in which the closed loop control is entirely on the robot side and the human operator receives feedback from the robot (visual, haptics etc.) and sends commands to it through a Human Robot Interface (HRI).
- b. Fully automatic control, in which the closed loop control is entirely on the robot side and the human operator receives only feedback from the robot.

This structure provides a major functional specification for the design of the control system, in which all the modules must be interconnected. The control system must be always able to provide safe commands to the actuators, regardless of the state of the connection with the operator. The proposed control system is portable, modular and is divided in different layers (Figure 6).

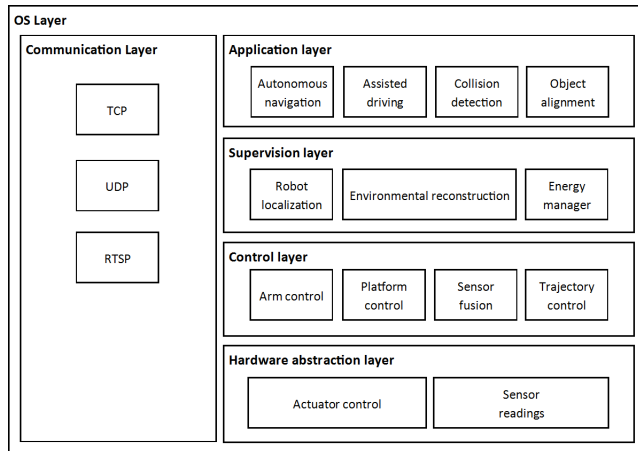

FIGURE 6. CERNTAURO control system architecture.

The Hardware Abstraction Layer (HAL) provides an interface between the system and the hardware. This layer is fundamental for the development of a modular and an adaptable system since it provides an abstraction interface between the hardware and the upper layers.

Furthermore, the HAL also allows the use and test of modules belonging to upper layers by using simulated hardware. This is extremely important for the system validation, operational procedures, and recovery scenarios and for the offline operators’ training, who can operate a simulated robot in advance as a preparation for the real intervention. The control layer provides all the control strategies for the actuators including the robotic arm controls (e.g. position control, trajectory control, kinematic control, torque control) and the robotic platform control (e.g. speed regulation, omnidirectional control).

The supervision layer contains all the modules which are responsible for determining the complete state of the system in each moment. It contains therefore the robot localization,

environmental reconstruction, the battery management, the communication optimization, etc. Finally, the application layer contains all the features that the robot can provide such as assisted and autonomous navigation [72], collision avoidance [73], autonomous object recognition and alignment [74], as well as a sequencer of multiple operations. Each part is treated as a HAL with a standard interface for the COS. This allows flexibility and portability of the proposed software, which can be adapted to different robotic types and hardware. In Figure 7, the software communication diagram implemented in the proposed framework is presented.

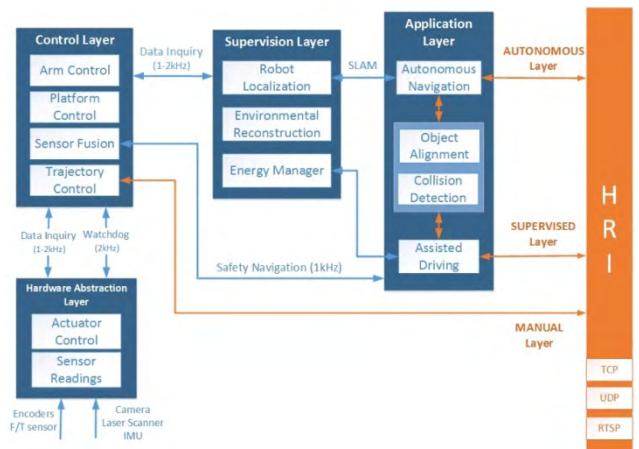

FIGURE 7. Software communication diagram.

In addition to the mentioned control layers, there are two layers which span the entire system: the communication layer and the OS layer. The communication layer provides all the communication methods with the HRI including methods for timestamp synchronization between the HRI and the robot, as well as communication compression and optimization methods.

The communication layer is connected with all the modules, since each module can provide and receive, if requested, data to and from the HRI. Above all, the OS layer provides all the functionalities in order to maintain all the modules properly active and interconnected.

All the modules communicate together through Inter Process Communication (IPC) but not all the modules are active simultaneously and modules can be activated or deactivated automatically or by the operator according to the needs. When a new module is activated or deactivated, the OS layer manages the reconnection and the redirection of the IPC. For example, the operator can choose to drive the robotic platform by sending direct commands or by the use of the assisted driving module in the application layer. The driving commands also go through the energy management to optimize the power consumption of the system. Therefore, when the operator chooses to use the assisted driving, the OS layer automatically modifies all the affected IPC connections in order to adapt to the new control configuration.

The OS layer also provides watchdog functionalities; each module has its own priority and its own criticality.

According to its criticality and priority, if the module suddenly stops, the watchdog detects this stop and manages it, by restarting it or by interrupting other modules in order to maintain the system in a safe state. As it has been conceived and realized, the COS is multi-platform and compatible with real-time controllers, features which are absent in the most common robotic control systems, such as in ROS [75].

Thanks to its implementation, the COS is light and it can manage several sub-tasks like SLAM [76], [77], autonomous navigation, data acquisition, robotic controls among others, in parallel and on-board.

The proposed novel control system has been conceived also to be a complement of ROS [78] (Table 5).

TABLE 5. Some CERNTAURO added values with respect to ROS.

Feature	ROS	CENTAURO
Multiplatform	No	YES
Computational needs	Needs a middle level computer	Runs on industrial NUCs and embedded PCs
Real time control	No	Control full real-time system compatible
Safety: control tolerant to environmental disturbance (e.g. radiation)	No	YES. Triple modular redundancy to avoid single event effect due to radiation
Real-Time messaging	YES but needs some updating	YES
Reconfigurable GUI with different robots	NO	YES
3D Setup tool	NO	YES, <i>VERO</i> module
Data security	NO	YES
Software verification and validation	NO	YES
Final scope	Intended for university and R&D applications	Intervention in real scenarios as well as R&D

1) SAFETY AND OBSTACLE AVOIDANCE

To ensure the safety of the robotic system and the machines to be maintained and inspected, as well as increasing the uptime of the plants, a real-time reconfigurable self-collision avoidance system coupled to a virtual augmented reality scenario is fundamental to help the operator during the intervention. The actuator control module of the CERNTAURO COS is featured with a novel real-time anti-collision system in between the robot components and in between robots and environments. The collision avoidance system is adaptable to the current robot hardware and software configurations.

An important novelty of the proposed solution is the capability to be adaptable to different robot configurations and

installations, taking into account different parameters like the type and the number of robotic arms, as well as their orientation. The system is capable of avoiding collision, not only within the robot itself, but also with external unexpected objects. The collision avoidance system defines virtual objects according to a configuration file, which considers the on-board modules.

The virtual objects envelope all the desired hardware systems while any control is being performed. The new commands sent to the robot are checked to be safe and feasible by computing the next location of all systems for self-collision avoidance. In case the distance of several virtual objects is less than a pre-defined threshold, the system is found in collision and stopped until the next control command is above this value. The virtual objects can be displayed through the HRI as the ones presented by providing feedback to the operator of the systems which are on course for collision.

Additionally, by deploying RGB-D cameras in the system, the safety system can provide collision avoidance in semi-structured and dynamic environments. Collisions can be avoided between robotic systems and unknown objects such as an operator, enhancing the safety in cluttered environments. This semi-structured environment can be modeled in several different ways as is most suitable to the application [73].

2) PERCEPTION AND 3D ONLINE RECONSTRUCTION

Preparing remote or human interventions in hazardous, unknown and semi-structured environments is a problematic task. The intervention should focus on the optimization of the operations in order to reduce the personnel exposure to hazards.

Optimizing these operations is not always possible, due to a lack of information about the intervention environment. Such information can be collected through a robotic inspection before the preparation of the intervention. The data collected during this inspection, such as radiation, temperature and oxygen level, must be accurate and precisely positioned in the environment in order to optimize a human beings' approach path and their stay in the intervention area. The framework includes a system for collecting physical quantities precisely positioned in the environment, which is easy to use by the robot operator and is seamlessly integrated in the robot control [79]. Using augmented reality, the operator is helped by the system in finding the most dangerous zones, which collects all the sensor readings while building a 3D model of the environment by using different RGB-D cameras installed on the robotic platform.

The system follows the following pipeline for the generation of accurate environmental maps.

- Data collection and transfer
- Surface reconstruction
- Sensor fusion for augmented reality 3D reconstruction:
- Assisted control

The operator is driven using a gradient ascending method to “hot zones” to better characterize those areas. The HRI computes the gradient of the physical dimension of interest while moving and it helps the operator, by slightly correcting their commands, to follow the computed gradient. This is done by computing the sum of the velocity vector coming from the operator’s commands while respecting the global reference frame and the gradient of the physical dimension in that point.

3) VISION DRIVEN CONTROL AND AUGMENTED REALITY SYSTEM

In tele-operation it is necessary to give the operator the correct feedback on the position of the robot with respect to the environment possibly using augmented reality. Based on robotic operational intervention feedback in the CERN accelerator complexes and specifically designed and implemented for grasping [80] and fine tasks [81], the CERNTAURO tracking system has been developed and commissioned. The CERNTAURO tracking system allows the operator to choose a region of interest (ROI) on any robot camera images and the system will guide the robot movements in a way that the selected ROI will always stay in the center of the selected camera images (see Figure 8). The core of the tracking system is based on Kernelized Correlation Filters (KCF) algorithms [82].

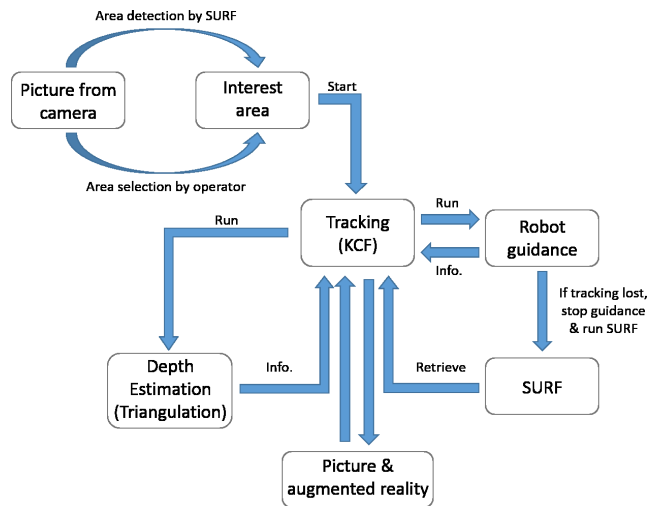

FIGURE 8. Scheme of the CERNTAURO tracking system.

The KCF method has a limitation due to partial occlusions that in the proposed method has been resolved splitting the ROI in 4 sub-regions that are treated like a single tracker (Figure 9). The movement of the four squares are related using Euclidean distances with adapted thresholds [83]. Using triangulation methods during robot and camera movements, the system will give to the operator as augmented reality information, in real-time, the estimated distance from the selected area in the ROI chosen.

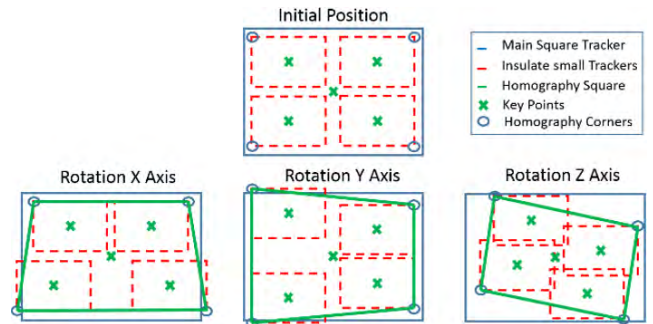

FIGURE 9. Idea of splitting the operator image ROI in 4 sub-regions individually tracked and connected using Euclidian distances.

4) AUTONOMOUS NAVIGATION AND WORKPLACE APPROACH

In most situations, it is very important to localize precisely the robot in the environment, for various reasons: data localization in the environment, robot localization for collaboration and automatic recovery in case of unexpected problem. Therefore it is important that the robot is able to localize itself automatically and build a model of the explored environment. This technique is commonly called Simultaneous Localization and Mapping (SLAM). SLAM algorithms compute the likelihood of both the robot’s pose and the environment by the use of onboard sensors, the only solution available in GPS-denied environments. The proposed framework integrates an incremental SLAM algorithm [72], which is computationally lightweight and uses a minimal set of sensors in order to be deployable on embedded systems. However, it is extendable and tunable in order to be adapted to different robot configurations in terms of sensor and processing power. Autonomous navigation in harsh environments must consider not only the spatial constraints (obstacles, narrow spaces, robot’s dimensions etc.) but also all the conditions which could be harmful for the robot itself such as high temperatures, high radiation, water leaks or even Wi-Fi and GSM signal strength for the communication between the robot and the operator. Therefore, the robot, while navigating, collects not only spatial information but also environmental data coming from the onboard sensors. Such data is localized and inserted in the map and it is used as an additional constraint for the path planning algorithm. Once the path planning algorithm is called, a virtual map is built starting from the environmental map generated by the SLAM algorithm (Figure 10).

On this map, virtual obstacles are added according to the environmental data collected. The shape of the virtual obstacle depends on the environmental characteristic of the physical quantity. By means of interpolation functions, physical data can be roughly predicted within a few meters from the robot and can be inserted as well as an obstacle in the virtual map. Thanks to the autonomous navigation module, the robot is able to navigate autonomously in an environment. Once the robot is close to the workplace, a correct robot workspace approach is fundamental for a precise pose of the robot with respect to the environment, possibly following a predefined

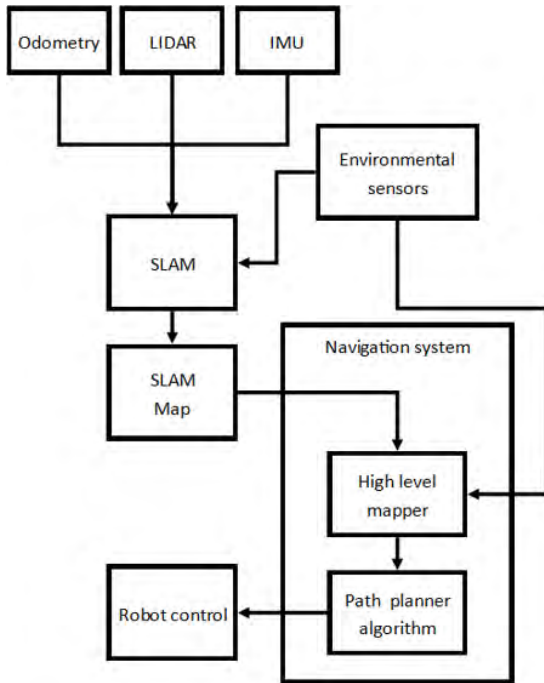

FIGURE 10. Scheme of the proposed autonomous navigation system.

trajectory learned in mock-ups or in simulations. For this purpose, a new pose estimation system for precise robotic manipulation in unstructured environment has been developed [74]. While the robot scans the area using the perception and the 3D online reconstruction module, it matches the point cloud with 3D CAD model to recover the correct pose of an object with respect to the robot. The novel proposed system integrates deep learning techniques to help the system find regions of interest to help the image segmentation process. The learning framework used is Tensorflow using Faster-RCNN and RESNET101 as neural networks [84].

5) COMMUNICATION

When dealing with Internet protocol-based communication, multiple aspects must be taken into account, which are not considered in a point-to-point radio communication. The congestion of the network must be considered: when controlling a robot deployed in an underground area several kilometers from the control station, several nodes are crossed, and the performance of the communication will therefore be affected by the workload of such nodes.

Furthermore, the two main transport layer protocols on the Internet protocol stack are TCP and UDP with their own features and drawbacks. Therefore, the communication between the operator and the robot should be semantically divided in order to use the best protocol according to the data to be sent. The communication layer of the proposed framework was designed to mitigate and control these drawbacks when using internet-based communication.

The first important aspect is the measurement of the delay between the HRI and the robot. To do this, a synchronization

of the timestamps between the robot and the HRI is performed at the first connection with the robot (Figure 11). This synchronization is based on the four timestamp mechanism of the Network Time Protocol (NTP) [79], [85], [86]. This mechanism measures the transmission delay between communicating nodes and uses this to estimate the offset between their respective clocks, in order to determine the error in the client nodes clock with respect to the time server's clock. Once the timestamps are synchronized, a custom application layer protocol has been created. In the header of each packet of this protocol, the timestamp is included at the time of sending the packet in the network. When the packet is received, the timestamp is compared with the current one, obtaining therefore the communication delay of each packet. This is used both on the robot's side as well as on the HRI's side. The controls of the operator are modified through a time-delay passivation system according to the measured delay. The result is that if the delay is low, the robot will move properly, while if the delay is high, all the control commands will be damped, reducing the speed of the robot. Thanks to this design, the control of the entire master-slave system is based on what the operator sees and feels through the haptic interfaces.

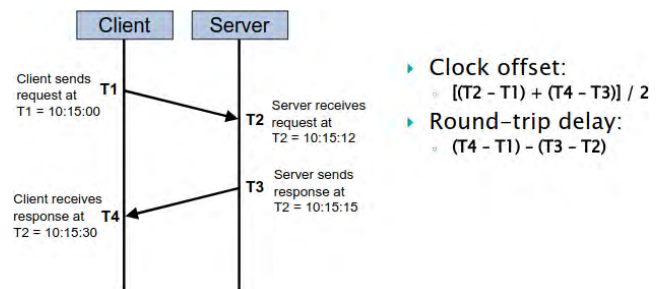

FIGURE 11. Communication synchronization scheme.

C. HUMAN-ROBOT INTERFACE

Even though the control system allows the robot to operate in a safe and robust way, it is important that the operator sends the proper commands to the robot. Therefore, a deep study for the creation of a usable, learnable and multi-modal Human-Robot Interface has been accomplished [64]. The interface provides a comfortable and uniform environment for the control of different robots, for the analysis of the collected data and for the training through simulation (Figure 12). Studies on the stress of the operator during an intervention were performed in order to design a HRI which optimizes the mental workload for the operator and the maximum telepresence in the environment. The multimodality is achieved by the integration in the HRI of different ways for interacting with the robotic system. Several control methods using different input devices are integrated. These include standard input devices such as keyboard, mouse and joysticks, together with more complex devices such as haptic devices for master slave telemanipulation and RGB-D cameras for body tracking. The operator can then choose, at any time,



FIGURE 12. Screenshot of the CERNTAURO HRI during operations.

the input device he is most comfortable with according to the skills, the type of operation that has to be performed, and the mental status and so on. Furthermore, the HRI adapts itself to the robot configuration, displaying only relevant information without filling the working memory of the operator. The HRI is highly learnable and the procedures are well-defined in order to reduce slips and lapses. Since the HRI is able to control different robots, the operator always receives the same feedback and always applies the same actuation commands. The two focal points are its usability and its user-friendliness. These aspects are essential to reduce the learning time of the operator and its associated hassle.

Reducing the learning time also means enlarging the operators' pool of a company, which, instead of having a few, well-trained operators which operate in all situations, could provide the robotic system directly to the facility expert, who has more knowledge of the environment.

1) USER FRIENDLY TELE-MANIPULATION SYSTEM

In most of the proposed bilateral master-slave systems, the master side is mainly composed of the HRI, which allows the operators to interface with the entire system and to control directly the slave robot using sample devices like keyboards and joysticks. While those instruments enable the precise control of the manipulator and fulfill most of the required tasks, they lack one of the most important aspects of a tele-manipulation system: the haptic feedback. In order to obtain the transparency of the system, the interaction of the slave robot with the remote environment has to be reported on the operator, which is the reason why an active master device is required.

The CERNTAURO system includes, as a master device, a robotic manipulator that solves the aforementioned problem and achieves the required haptic feature. The interaction of the master manipulator with the human operator is handled using a specific impedance control, which is able to reduce the inertia perceived by the operator making the manipulator light and flexible to move in every configuration of the space. The bilateral architecture control developed (see Figure 13) arises from the most general 4-Channel architecture [87], in which master and slaves can exchange forces and positions/velocities signals. The architecture in

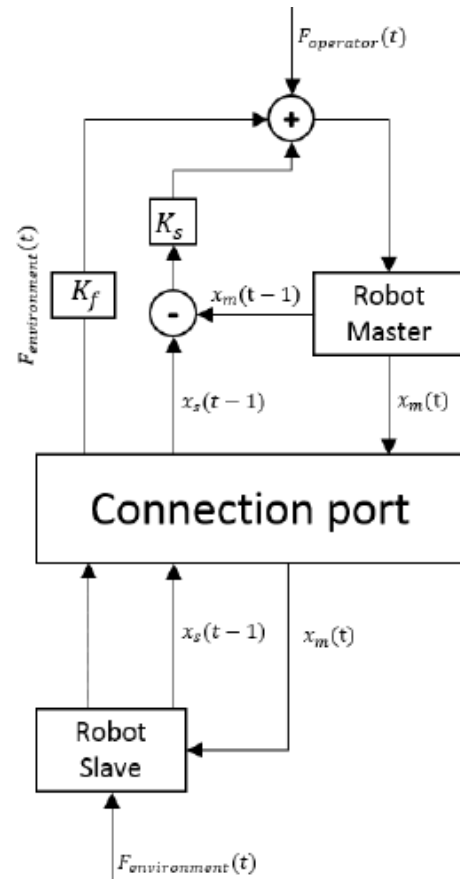

FIGURE 13. Bilateral control scheme.

the framework is composed of three channels: two are used for shared position/velocity information between master and slave and a third used to replace the environment interaction forces from the slave to the master. The specific chosen architecture is known as “Environmental Force Compensated (EFC)” whose stability and transparency have been well discussed [88], also in presence of time delay [89].

In the proposed solution, the operator feels two different kinds of force feedback, a direct one directly from the force sensor, and an indirect one caused by position or velocity error in between the master and the slave positions. The approach of the proposed framework used to accomplish autonomous tasks in harsh environments is the integration of an online modifiable trajectory generation system known as Dynamic Movement Primitives (DMP) and learning by demonstration algorithms [90].

The system relies on a learning phase which starts with kinematic demonstrations of the robot, done by a human operator. The demonstrations are encoded and learnt using locally weighted regression (LWR). With this information a dynamic movement primitives is created and stored in a database for later use. In the operational phase, an operator chooses a task to perform and a selection of DMPs are made from the library. From here, there are two modes formulated to make use of the DMPs.

The assistive mode looks to perform tasks with the interaction between human and robot (meant for supervised tele-operated tasks). On the other hand, the autonomous mode looks for task completion in a fully automated way. Both modes work with a compliant behavior that is achieved through the modification of the DMP's canonical system and use of an impedance controller (Figure 14).

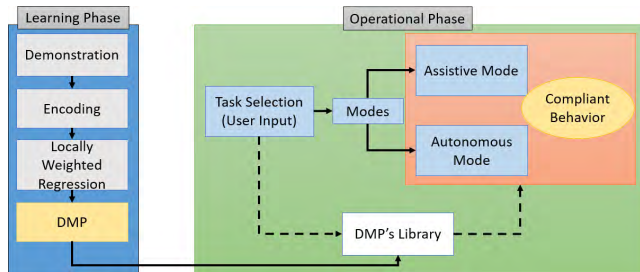

FIGURE 14. Learning by demonstration architecture.

V. DISCUSSION

Table 6 summarizes the added values of CERNTAURO with respect to the state of the art used for robotic interventions [91], [92].

TABLE 6. Some CERNTAURO added values with respect to the state of art.

Feature	State of Art solution	CERNTAURO solution	Added value
Intervention preparation	ITER code of practice	VERO	Virtual reality and flexibility
Autonomous navigation	ROS	Novel particle filter based SLAM	Speed and environment adaptability
Tele-operation	Military robot controllers	Transparent bilateral system and multimodal HRI	User friendliness and haptics
Operator training	Training area	Simulated environment using Virtual Reality	Time, space, cost and flexibility

The proposed solution has been validated since September 2016 through 82 robotic operations (Figure 15) in the CERN accelerator facilities, fulfilling 132 tasks, operating the robots for 220 hours, saving human exposure to radiation (Figure 16) maximizing machine uptime.

The CERNTAURO solution has been successfully integrated on several robotic arms (Figure 17), as well as the following robots designed and built at CERN:

- ✓ CERNbot v1.0
- ✓ CERNbot v2.0
- ✓ CRANEbot
- ✓ Train Inspection Monorail for the LHC [43]

Different robots running the CERNTAURO framework have successfully achieved, in assisted teleoperation, dexterous tasks like screwing, sewing, cutting, grasping etc., as well as autonomous inspections in harsh and semi-structured environments (TABLE 7).

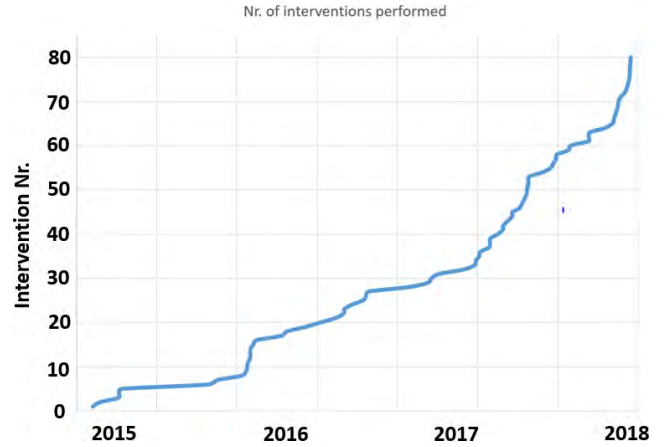

FIGURE 15. Timeline of the intervention performed during the last years using the CERNTAURO framework on different robots.

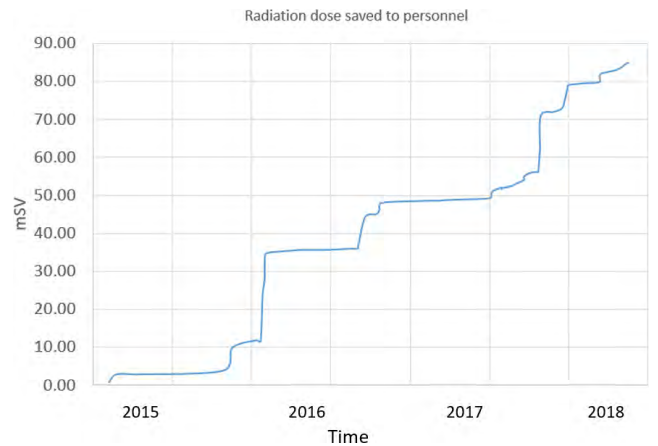

FIGURE 16. Radiation exposure saved to CERN personnel by using the CERNTAURO framework deployed on different robots.



FIGURE 17. Robotic arms controlled by the CERNTAURO framework.

CERNbot v1.0 and v2.0 [42] and CRANEbot (Figure 18), novel robotic base systems, have been built at CERN with the goal of guaranteeing autonomous inspection and supervised telemanipulation in the accelerator areas. The CERNbot robotic platform has been designed to guarantee the maximum flexibility from the mechanical and electrical point of views (Figure 19). The structure is divided in subsystems. Each subsystem could be modified separately

TABLE 7. Types of intervention performed using the CERNTAURO framework.

Intervention type	Number of times performed	Hours of in-situ operation	Hours of operator training
Environmental measurements	35	60	10
Telemanipulation (grasping, cutting, screwing, sewing etc.)	45	140	350
Personnel escort for safety	2	5	15
Reconnaissance and visual inspections	50	45	5

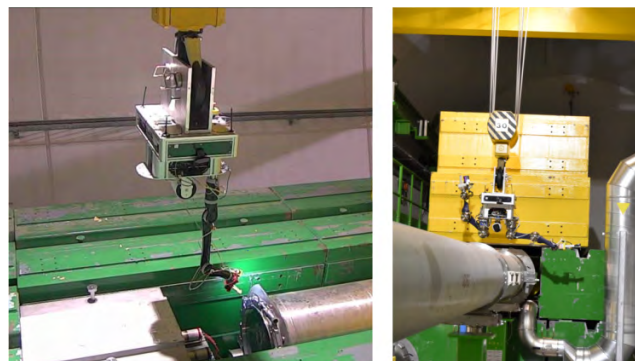

FIGURE 20. CERNbot core in dual-arms configuration integrated on a crane for accessing complicated areas (CRANEbot).



FIGURE 21. Robots in operation dismantling a beam dump water disconnection at CERN.



FIGURE 22. CERNbot doing autonomous radiation mapping of accelerator areas at CERN.



FIGURE 18. CERNbot v1.0 in single and dual arms configuration (left). CERNbot v2.0 with lifting stage in dual arms configuration (middle). CERNbot core (CRANEbot) in dual arms configuration (right).

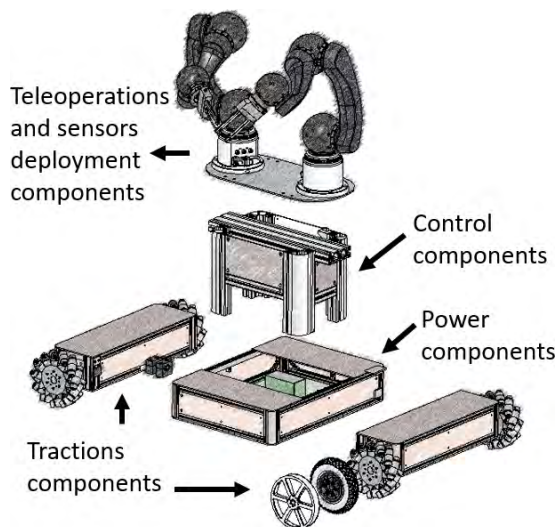

FIGURE 19. CERNbot modular architecture.

and adapted to the different use and needs of the robotic platform (Figure 20).

The CERNbot and CRANEbot have been running the CERNTAURO framework in hazardous accelerator areas at CERN (Figure 20, Figure 21, Figure 22), reducing personnel exposure to radiation and increasing machine uptime [42].

To verify the goodness of the proposed teleoperation solution, the transparency [93], [94] and the stability [95], [96] have been used. Regarding the transparency, the robot inertia perceived by the operator from the master side has been reduced setting up correctly the velocity-force parameters in order to perceive only the force reflected from the remote environment (e.g. force feedbacks from the slave's torque sensor). For the stability, using Lyapunov equations and passivity theories, the bilateral architecture chosen has been demonstrated to be stable [97] and the robustness of the

system has been validated during the real interventions performed in harsh and semi-structured environment.

The intuitive HRI coupled with the stable and transparent bilateral telemanipulation system guarantees user friendliness, demonstrated from the fact that the system has been used with success also by non-trained operators (Figure 23).

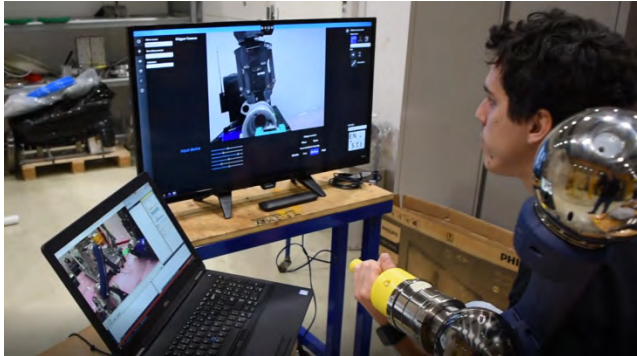

FIGURE 23. CERNTAURO master-slave bilateral system in operation during a fine grasping and screwing task of a radioactive target used at CERN facilities. In this case master and slave have the same robot arms.

The proposed system has been compared with different industrial ones [52] in achieving a screwing task using two categories of operators, six well-trained and twenty un-trained ones monitoring the heartbeat (TABLE 8 and TABLE 9).

TABLE 8. Time results obtained during the fulfilling of the screwing task.

Device	Un-trained users set [s]	Well-trained users set [s]
CERNTAURO	412 ± 9	114 ± 2
Robotic Industrial System	Failed	213 ± 31

TABLE 9. Heartbeat percentage increase during the fulfilling of the screwing task.

Device	Un-trained users set	Well-trained users set
CERNTAURO	25%	10%
Robotic Industrial System	50%	15%

Using the CERNTAURO framework, all of the un-trained operators were able to fulfill the assigned tasks with success, unlike with the use of the industrial ones. The un-trained operators declared that the force feedback has played a key role in positioning the robot in the best configuration for the task realization. In addition, a significant increase in temporal efficiency and robustness were observed also by the trained operators in using the CERNTAURO system, as well as a decrease in heartbeat activity. This demonstrates how the proposed system could be a meaningful added value in the field of teleoperation.

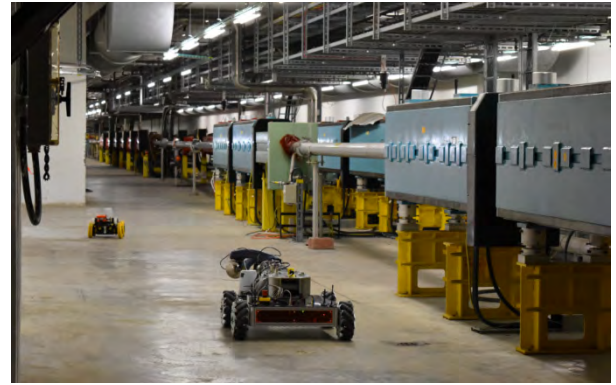

FIGURE 24. CERNbot v1.0 and EXTRM in North Area beamline.

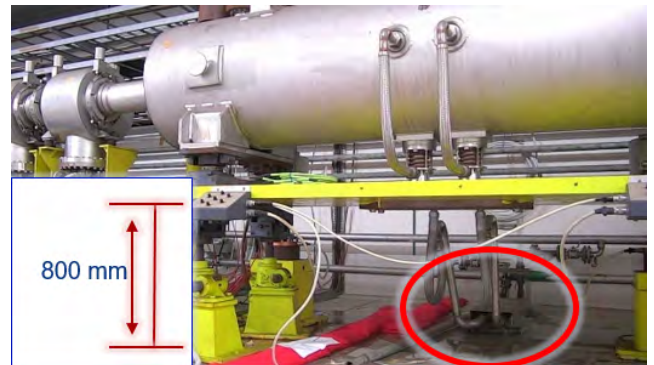

FIGURE 25. Location of the water leak.

VI. INTERVENTION EXAMPLE Nr.1: IN-SITU WATER LEAK REPAIR

One of the different successful mission that the CERNTAURO framework has done is an in-situ repair of a water leak present in a water-cooling pipe serving a proton beam collimator in the North Experimental area [98] at CERN. The location of the broken pipe below the collimator was challenging, in addition to the high radiation and fragility of the equipment (Figure 24 and Figure 25). The in-situ tasks were mainly to free the area around the leak location cutting different metal sheets using an ad-hoc tool and enclosing the broken pipe by building a container around the broken spot. The pipe's leak location has been enclosed and filled with special radiation hard resin to seal the leak (Figure 26). The intervention pipeline followed all the CERNTAURO framework steps. The compliant master slave control of the CERNTAURO framework demonstrated its versatility for different delicate tasks like precisely injecting the resin and for more harsh tasks like cutting 5 mm metal sheets using ad-hoc tools.

VII. INTERVENTION EXAMPLE Nr.2: REFILLING OF OIL TANKS

Another successful mission that the CERNTAURO framework has done is an in-situ survey and filling of 25 oil recipients on the magnetic beam kickers of the Super Proton Synchrotron accelerator [99]. at CERN (Figure 27).

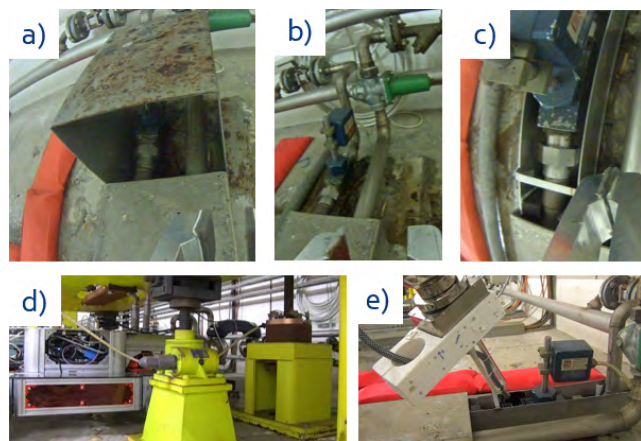

FIGURE 26. Water leak area before (a) and after the intervention with the resin injected (e). Metal cover cut (b). Building the recipient to confine the leak area (c). CERNbot running CERNTAURO framework below the collimator.

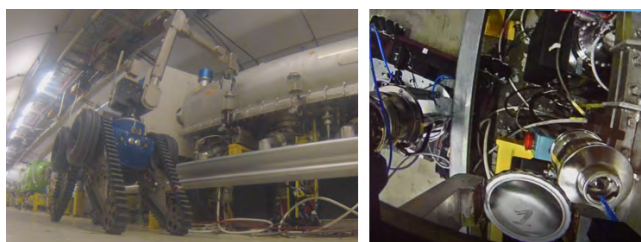

FIGURE 27. Filling of oil recipient done using industrial solution (left) and custom made solution using CERNTAURO framework (right).

In the past years this task has been accomplished using industrial robots and industrial controls [41]. By using the CERNTAURO framework, the mission time has been reduced increasing the machine availability and reducing human exposure to radiation because the operators are operating outside of the tunnel and far from hazards, as was not the case in the past years where standard industrial solutions were used.

VIII. INTERVENTION EXAMPLE Nr.3: RADIOACTIVE SOURCE HANDLING

Another success has been the handling of a radioactive iridium source. The radioactive source had a length of 20 mm and had to be removed from a radioactive transport container, taken out from its support, then being integrated into another support and the whole assembly was put in an experimental container that is irradiated by the Proton Synchrotron beam in the frame of the Antimatter Production facility [100] at CERN. For this intervention, CERNbot running CERNTAURO framework and equipped with an elevating stage and dual robotic arm system (a Kinova for fine telemanipulation and Schunk Powerball for high payload tasks) was used (Figure 28). Specific tools and procedures were built following the proposed framework approach.

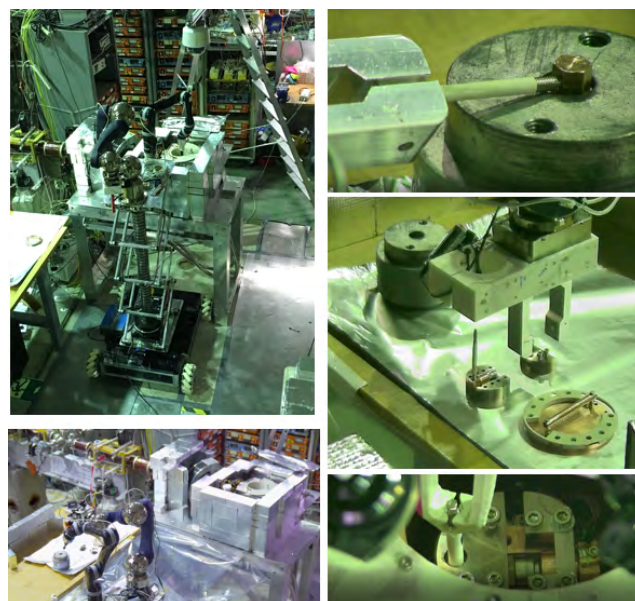

FIGURE 28. CERNbot in dual arm configuration (left pictures) and the iridium radioactive source handling (right pictures).

IX. CONCLUSION

In the last years, highly sophisticated algorithms and techniques like deep and broad learning have increased robot perception and learning, setting the base for future self-sustainable robots and opening discussions on ethical aspects not discussed in this work. From the mechatronic point of view, physics is the only limits to human creations but on the contrary, considering modern machine learning techniques, the technological limits are not yet well defined. The motivation of the proposed work is that robots must improve the quality of our lives and work by taking over dangerous, tedious, and dirty jobs which are not possible or safe for humans to perform. Robots can learn and reproduce what humans program but they will never be fully safe, bug-free or have ethical behavior. For this reason, autonomous robots are not currently suitable to intervene for the maintenance of expensive and delicate machines and tele-operation is currently the only solution. A user-friendly robot human interface coupled with artificial means (e.g. learning, virtual and augmented reality) are essential to help the operator perform robotic tasks in a comfortable way, increasing the success rate and safety, and decreasing the intervention time. A novel robotic tele-manipulation framework for harsh and hazardous environments was developed, commissioned and is currently in operation in the CERN accelerator complexes. The new framework is transportable on different robots thanks to a configuration layer, which takes several factors into account such as the type of hardware, communication layer, and operator needs. The novel system is adaptable on different robots and can perform unmanned tasks in hazardous and semi-structured environments.

The CERNTAURO architecture has demonstrated to be very efficient in terms of reliability and safety, according to

the results obtained from more than 80 real interventions. Moreover, next step is preparing the architecture for future cooperative multi-robot interventions, such as grasping and transporting objects (e.g pipes), that nowadays are being performed by using two operators, with also two mobile manipulators.

As can be appreciated in Figure 3, the enhanced architecture for cooperative multi-robot interventions is prepared to deploy a Wi-Fi Local Area Network on the robotic side, having a Leader as the main mobile platform, where the data distribution unit module is running, acting also as router from the Wi-Fi LAN Robotic team and the external 3G/4G network. Also, from the user interface side, in order to enhance the safety of the operation, is agreed to have an expert operator per mobile manipulator, having a leader operator that has access to the Cooperative Planner user interface module, where responsibilities can be shared with the assistant operator, in terms of supervising a given mobile manipulator during the intervention phase. Also, the leader operator will assign the roles of robotic relays and autonomous robots, which will for example follow a particular leader to give a specific external point of view of the target during intervention.

ACKNOWLEDGMENT

The authors would like to thank Prof. Raul Marin Prades for his precious suggestions, support and revisions of the presented work.

REFERENCES

- [1] K. Schwab, *The Fourth Industrial Revolution*. Geneva, Switzerland: World Economic Forum, 2016.
- [2] Z. Qin, G. Denker, C. Giannelli, P. Bellavista, and N. Venkatasubramanian, "A software defined networking architecture for the Internet-of-Things," in *Proc. IEEE Netw. Oper. Manage. Symp. (NOMS)*, May 2014, pp. 1–9.
- [3] Y. Cho, J. Choi, J. Choi, and Y.-J. Ryoo, "Robot software platform for IoT-based context-awareness," *Int. J. Humanoid Robot.*, vol. 14, no. 2, p. 1750012, 2017, doi: [10.1142/S0219843617500128](https://doi.org/10.1142/S0219843617500128).
- [4] T. Yoshida, K. Nagatani, S. Tadokoro, T. Nishimura, and E. Koyanagi, "Improvements to the rescue robot quince toward future indoor surveillance missions in the Fukushima Daiichi nuclear power plant," in *Field and Service Robotics*. Berlin, Germany: Springer, 2014.
- [5] J. P. Fricconneau, V. Beaudoin, A. Dammann, C. Dremel, J. P. Martins, and C. S. Pitchera, "ITER hot cell—Remote handling system maintenance overview," *Fusion Eng. Des.*, vol. 124, pp. 673–676, Nov. 2017.
- [6] A. W. Chao, Eds., *Handbook of Accelerator Physics and Engineering*. Singapore: World Scientific, 2013.
- [7] C. Lefevre, *The CERN Accelerator Complex*, document CERN-DI-0812015, 2008.
- [8] M. Altarelli et al., "The European X-ray free-electron laser," DESY, Tech. Rep., 2006, pp. 1–26, vol. 97.
- [9] L. Hoddeson et al., "Fermilab: Physics, the frontier, and megascience," *Amer. J. Phys.*, vol. 77, no. 7, pp. 671–672, 2009.
- [10] M. Hvilshøj, S. Bøgh, O. S. Nielsen, and O. Madsen, "Autonomous industrial mobile manipulation (AIMM): Past, present and future," *Ind. Robot, Int. J.*, vol. 39, no. 2, pp. 120–135, 2012.
- [11] R. Buckingham and A. Loving, "Remote-handling challenges in fusion research and beyond," *Nature Phys.*, vol. 12, no. 5, pp. 391–393, 2017.
- [12] A. Gutiérrez-Giles and A. M. Arteaga-Pérez, "Transparent bilateral teleoperation interacting with unknown remote surfaces with a force/velocity observer design," *Int. J. Control*, pp. 1–18, Sep. 2017.
- [13] W. J. Manion and T. S. LaGuardia, "Decommissioning handbook," Nucl. Energy Services Inc., Danbury, CT, USA, Tech. Rep. DOE/EV/10128-1 and RLO/SFM-80-3, 1980.
- [14] M. E. Rosheim, *Robot Evolution: The Development of Anthropotics*. Hoboken, NJ, USA: Wiley, 1994.
- [15] L. G. García-Valdovinos et al., "Modelling, design and robust control of a remotely operated underwater vehicle," *Int. J. Adv. Robotic Syst.*, vol. 11, no. 1, pp. 1–16, 2014.
- [16] J. J. Leonard and A. Bahr, "Autonomous underwater vehicle navigation," in *Springer Handbook of Ocean Engineering*. Springer, 2016, pp. 341–358.
- [17] T. Lozano-Perez, *Autonomous Robot Vehicles*. New York, NY, USA: Springer, 2012.
- [18] J. E. Manley, "Unmanned surface vehicles, 15 years of development," in *Proc. IEEE OCEANS*, Sep. 2008, pp. 1–4.
- [19] G. De Novi, C. Melchiorri, J. C. García, P. J. Sanz, P. Ridao, and G. Oliver, "New approach for a reconfigurable autonomous underwater vehicle for intervention," *IEEE Aerosp. Electron. Syst. Mag.*, vol. 25, no. 11, pp. 32–36, Nov. 2010.
- [20] A. Shukla and H. Karki, "Application of robotics in onshore oil and gas industry—A review Part I," *Robot. Auto. Syst.*, vol. 75, pp. 490–507, Jan. 2016.
- [21] A. Shukla and K. Hamad, "Application of robotics in offshore oil and gas industry—A review Part II," *Robot. Auton. Syst.*, vol. 75, pp. 508–524, Jan. 2016.
- [22] M. Rossi, D. Brunelli, A. Adami, L. Lorenzelli, F. Menna, and F. Remondino, "Gas-drone: Portable gas sensing system on UAVs for gas leakage localization," in *Proc. IEEE SENSORS*, Nov. 2014, pp. 1431–1434.
- [23] E. Feron and E. N. Johnson, "Aerial robotics," *Springer Handbook of Robotics*. Berlin, Germany: Springer, 2008, pp. 1009–1029.
- [24] D. W. Matolak and R. Sun, "Unmanned aircraft systems: Air-ground channel characterization for future applications," *IEEE Veh. Technol. Mag.*, vol. 10, no. 2, pp. 79–85, Jun. 2015.
- [25] J. Irizarry, G. Masoud, and B. N. Walker, "Usability assessment of drone technology as safety inspection tools," *J. Inf. Technol. Construction*, vol. 17, no. 12, pp. 194–212, 2012.
- [26] N. Sharkey, "The automation and proliferation of military drones and the protection of civilians," *Law, Innov. Technol.*, vol. 3, no. 2, pp. 229–240, 2011.
- [27] P. M. Asaro, "The labor of surveillance and bureaucratized killing: New subjectivities of military drone operators," *Soc. Semiotics*, vol. 23, no. 2, pp. 196–224, 2013.
- [28] K. Valavanis and G. J. Vachtsevanos, *Handbook of Unmanned Aerial Vehicles*. Dordrecht, The Netherlands, Springer, 2014.
- [29] A. Callam, "Drone wars: Armed unmanned aerial vehicles," *Int. Affairs Rev.*, vol. 18, no. 3, 2015.
- [30] G. Wild, J. Murray, and G. Baxter, "Exploring civil drone accidents and incidents to help prevent potential air disasters," *Aerospace*, vol. 3, no. 3, p. 22, 2016.
- [31] L. Pedersen, D. Kortenkamp, D. Wettergreen, and I. Nourbakhsh, "A survey of space robotics," NASA Ames Res. Center, Moffett Field, CA, USA, Tech. Rep. 20030054507, 2003.
- [32] M. Yim, K. Roufas, D. Duff, Y. Zhang, C. Eldershaw, and S. Homans, "Modular reconfigurable robots in space applications," *Auto. Robots*, vol. 14, no. 2, pp. 225–237, Mar. 2003.
- [33] M. Bajracharya et al., "Autonomy for Mars rovers: Past, present, and future," *Computer*, vol. 41, no. 12, pp. 44–50, 2008.
- [34] K. Yoshida, "Achievements in space robotics," *IEEE Robot. Autom. Mag.*, vol. 16, no. 4, pp. 20–28, Dec. 2009.
- [35] B. G. Drake, S. J. Hoffman, and D. W. Beaty, "Human exploration of Mars, design reference architecture 5.0," in *Proc. IEEE Aerosp. Conf.*, Mar. 2010, pp. 1–24.
- [36] D. W. Hainsworth, "Teleoperation user interfaces for mining robotics," *Auto. Robots*, vol. 11, no. 1, pp. 19–28, 2001.
- [37] P. Corke et al., "Mining robotics," in *Springer Handbook of Robotics*. Berlin, Germany: Springer, 2008, pp. 1127–1150.
- [38] J. Y. Chen, "UAV-guided navigation for ground robot tele-operation in a military reconnaissance environment," *Ergonomics*, vol. 53, no. 8, pp. 940–950, 2010.
- [39] J. Paul, *Military Robots and Drones: A Reference Handbook*. Santa Barbara, CA, USA: ABC-CLIO, 2013.
- [40] H. Balta, H. Wolfmayr, J. Braunstein, and Y. van Baudoïn, "Integrated mobile robot system for landmine detection," HUDEM, Zadar, Croatia, Tech. Rep., 2014.

- [41] G. de Cubber, H. Balta, and C. Lietart, "Teodor: A semi-autonomous search and rescue and demining robot," *Appl. Mech. Mater.*, vol. 658, pp. 599–605, Oct. 2014.
- [42] M. Di Castro et al., "A dual arms robotic platform control for navigation, inspection and telemanipulation," in *Proc. ICALEPCS*, 2018, pp. 709–713.
- [43] M. Di Castro et al., "LHC train control system for autonomous inspections and measurements," in *Proc. ICALEPCS*, 2018, pp. 1507–1511.
- [44] J. V. Draper, W. E. Moore, J. N. Herndon, and B. S. Weil, "Effects of force reflection on servomanipulator task performance," in *Proc. Int. Topical Meeting Robot. Remote Handling Hostile Environ.*, 1987.
- [45] R. C. Goertz, "Manipulator systems development at ANL," in *Proc. 12th Remote Syst. Technol., Amer. Nucl. Soc.*, vol. 12, 1964, p. 123.
- [46] T. B. Sheridan, *Telerobotics, Automation, and Human Supervisory Control*. Cambridge, MA, USA: MIT Press, 1992.
- [47] J. Schuler, *Integration von Förder-und Handhabungseinrichtungen*, vol. 104. New York, NY, USA: Springer-Verlag, 2013.
- [48] E. Helms, R. D. Schraft, and M. Hagele, "Rob@work: Robot assistant in industrial environments," in *Proc. 11th IEEE Int. Workshop*, Sep. 2002, pp. 399–404.
- [49] M. Hvilshøj, S. Bøgh, O. Madsen, and M. Kristiansen, "The mobile robot 'Little Helper': Concepts, ideas and working principles," in *Proc. IEEE Emerg. Technol. Factory Automat.*, Sep. 2009, pp. 1–4.
- [50] W. Garage. (2010). *Willow Garage*. [Online]. Available: <http://www.willowgarage.com/pages/pr2/overview>
- [51] TUM-Rosie. (2011). *TUM-Rosie*. [Online]. Available: <http://ias.cs.tum.edu/robots/tum/rosie/>
- [52] S. Costo and R. Molfino, "A new robotic unit for onboard airplanes bomb disposal," in *Proc. 35th Int. Symp. Robot. (ISR)*, 2004, pp. 23–26.
- [53] B. Siciliano and O. Khatib, Eds., *Springer Handbook of Robotics*. Berlin, Germany: Springer-Verlag, 2016.
- [54] J.-A. Meyer and G. Filliat, "Map-based navigation in mobile robots: II. A review of map-learning and path-planning strategies," *Cognit. Syst. Res.*, vol. 4, no. 4, pp. 283–317, Dec. 2003.
- [55] M. Ferre, Ed., *Advances in Telerobotics*, vol. 31. Heidelberg, Germany: Springer, 2007.
- [56] P. F. Hokayem and M. W. Spong, "Bilateral teleoperation: An historical survey," *Automatica*, vol. 42, no. 12, pp. 2035–2057, Dec. 2006.
- [57] S. Chitta, E. G. Jones, M. Ciocarlie, and K. Hsiao, "Mobile manipulation in unstructured environments: Perception, planning, and execution," *IEEE Robot. Autom. Mag.*, vol. 19, no. 2, pp. 58–71, Jun. 2012.
- [58] First-MM. *Flexible Skill Acquisition and Intuitive Robot Tasking for Mobile Manipulation in the Real World 2007–2013*. Accessed: Feb. 22, 2018. [Online]. Available: <http://www.first-mm.eu/>
- [59] TAPAS. *Robotics-enabled Logistics and Assistive Services for the Transformable Factory of the Future 2007–2013*. Accessed: Dec. 10, 2017. [Online]. Available: <http://www.tapas-project.eu/>
- [60] VALERI. *Validation of Advanced, Collaborative Robotics for Industrial Applications 2007–2013*. Accessed: Jan. 21, 2018. [Online]. Available: <http://www.valeri-project.eu>
- [61] Y. Wu, B. Zhang, S. Yang, X. Yi, and X. Yang, "Energy-efficient joint communication-motion planning for relay-assisted wireless robot surveillance," in *Proc. IEEE Conf. Comput. Commun.*, May 2017, pp. 1–9.
- [62] J. Jerald, P. Giokaris, D. Woodall, A. Hartbolt, A. Chandak, and S. Kuntz, "Developing virtual reality applications with Unity," in *Proc. IEEE Virtual Reality (VR)*, Mar./Apr. 2014, pp. 1–3.
- [63] J. W. Murray, *Building Virtual Reality With Unity and Steam VR*. Boca Raton, FL, USA: CRC Press, 2017.
- [64] G. Lunghi, R. M. Prades, and M. Di Castro, "An advanced, adaptive and multimodal graphical user interface for human-robot teleoperation in radioactive scenarios," in *Proc. 13th Int. Conf. Inform. Control, Automat. Robot.*, 2016, pp. 1–8.
- [65] L. Joseph, *Mastering ROS for Robotics Programming*. Birmingham, U.K.: Packt Publishing Ltd, 2015.
- [66] O. Özyeşil, V. Voroninski, R. Basri, and A. Singer, "A survey of structure from motion," *Acta Numerica*, vol. 26, pp. 305–364, May 2017.
- [67] M. L. Dingus, W. P. Zoch, T. R. Mayfield, A. Bray, and R. A. Rushing, "Methods and compositions for cleaning and decontamination," U.S. Patent 5 670 469, Sep. 23, 1997.
- [68] K. F. Langley and J. Williams, "Decontamination and waste minimisation techniques in nuclear decommissioning," *Nucl. Energy*, vol. 40, no. 3, pp. 189–195, 2001.
- [69] G. J. Butterworth, "Low activation structural materials for fusion," *Fusion Eng. Des.*, vol. 11, nos. 1–2 pp. 231–244, 1989.
- [70] C. Claeys and E. Simoen, *Radiation Effects in Advanced Semiconductor Materials and Devices*, vol. 57. Berlin, Germany: Springer-Verlag, 2013.
- [71] M. P. Rombach, M. A. Porter, J. H. Fowler, and P. J. Mucha, "Core-periphery structure in networks (revisited)," *SIAM J. Appl. Math.*, vol. 59, no. 3, pp. 619–646, 2014.
- [72] M. Di Castro, A. Masi, G. Lunghi, and R. Losito, "An incremental slam algorithm for indoor autonomous navigation," presented at the IMEKO, 2014.
- [73] M. Di Castro, D. B. Mulero, M. Ferre, and A. Masi, "A real-time reconfigurable collision avoidance system for robot manipulation," in *Proc. ACM 3rd Int. Conf. Mechatronics Robot. Eng.*, 2017, pp. 6–10.
- [74] M. Di Castro, J. C. Vera, A. Masi, and M. Ferre, "Novel pose estimation system for precise robotic manipulation in unstructured environment," in *Proc. 14th Int. Conf. Inform. Control, Autom. Robot.*, 2017, pp. 50–55.
- [75] M. Quigley et al., "ROS: An open-source robot operating system," in *Proc. ICRA Workshop Open Source Softw.*, 2009, vol. 3, nos. 3–2, p. 5.
- [76] S. Thrun, "Probabilistic robotics," *Commun. ACM*, vol. 45, no. 3, pp. 52–57, 2002.
- [77] M. W. M. G. Dissanayake, P. Newman, S. Clark, H. F. Durrant-Whyte, and M. Csorba, "A solution to the simultaneous localization and map building (SLAM) problem," *IEEE Trans. Robot. Autom.*, vol. 17, no. 3, pp. 229–241, Jun. 2001.
- [78] M. Pryor et al., "ROS-DOE: Leveraging open-source robotic software for the DOE-EM mission-17181," in *Proc. 43rd Waste Manage. Conf.*, 2017, p. 4855.
- [79] G. Lunghi et al., "An RGB-D based augmented reality 3D reconstruction system for robotic environmental inspection of radioactive areas," in *Proc. 14th Int. Conf. Inform. Control, Automat. Robot.*, 2017, pp. 233–238, doi: [10.5220/0006395802330238](https://doi.org/10.5220/0006395802330238).
- [80] A. Biechi and V. Kumar, "Robotic grasping and contact: A review," in *Proc. IEEE Int. Conf. ICRA*, vol. 1, Apr. 2000, pp. 348–353.
- [81] M. R. Cutkosky, *Robotic Grasping and Fine Manipulation*, vol. 6. New York, NY, USA: Springer, 2012.
- [82] J. F. Henriques, R. Caseiro, P. Martins, and J. Batista, "High-speed tracking with kernelized correlation filters," *IEEE Trans. Pattern Anal. Mach. Intell.*, vol. 37, no. 3, pp. 583–596, Mar. 2015.
- [83] P.-E. Danielsson, "Euclidean distance mapping," *Comput. Graph. Image Process.*, vol. 14, no. 3, pp. 227–248, 1980.
- [84] M. Abadi et al., "TensorFlow: A system for large-scale machine learning," in *Proc. OSDI*, vol. 16, 2016, pp. 1–21.
- [85] Accessed: Mar. 15, 2017. [Online]. Available: <https://tools.ietf.org/html/rfc5905>
- [86] G.-S. Tian, Y.-C. Tian, and C. Fidge, "High-precision relative clock synchronization using time stamp counters," in *Proc. 13th IEEE Int. Conf. Eng. Complex Comput. Syst. (ICECCS)*, Mar./Apr. 2008, pp. 69–78.
- [87] G. Niemeyer and J.-J.-E. Slotine, "Stable adaptive teleoperation," *IEEE J. Ocean. Eng.*, vol. 16, no. 1, pp. 152–162, Jan. 1991.
- [88] A. Haddadi, K. Razi, and K. Hashtrudi-Zaad, "Operator dynamics consideration for less conservative coupled stability condition in bilateral teleoperation," *IEEE/ASME Trans. Mechatronics*, vol. 20, no. 5, pp. 2463–2475, Oct. 2015.
- [89] A. Suzuki and K. Ohnishi, "Frequency-domain damping design for time-delayed bilateral teleoperation system based on modal space analysis," *IEEE Trans. Ind. Electron.*, vol. 60, no. 1, pp. 177–190, Jan. 2013.
- [90] J. Silvério, Y. Huang, L. Rozo, and S. Calinon. (Dec. 2017). "A learning from demonstration approach fusing torque controllers." [Online]. Available: <https://arxiv.org/abs/1712.07249>
- [91] I. Kostavelis and A. Gasteratos, "Robots in crisis management: A survey," in *Proc. Int. Conf. Inf. Syst. Crisis Response Manage. Medit. Countries*. Cham, Switzerland: Springer, 2017, pp. 43–56.
- [92] J. Guiochet, M. Machin, and H. Waeselynck, "Safety-critical advanced robots: A survey," *Robot. Auto. Syst.*, vol. 94, pp. 43–52, Aug. 2017.
- [93] K. Hashtrudi-Zaad and S. E. Salcudean, "Analysis of control architectures for teleoperation systems with impedance/admittance master and slave manipulators," *Int. J. Robot. Res.*, vol. 20, no. 6, pp. 419–445, 2001.
- [94] W. Iida and K. Ohnishi, "Reproducibility and operability in bilateral teleoperation," in *Proc. 8th IEEE Int. Workshop Adv. Motion Control (AMC)*, Mar. 2004, pp. 217–222.
- [95] A. Peer and M. Buss, "Robust stability analysis of a bilateral teleoperation system using the parameter space approach," in *Proc. IEEE/RSJ Int. Conf. Intell. Robots Syst. (IRO)*, Sep. 2008, pp. 2350–2356.
- [96] D. A. Lawrence, "Stability and transparency in bilateral teleoperation," *IEEE Trans. Robot. Autom.*, vol. 9, no. 5, pp. 624–637, Oct. 1993.

- [97] K. Hashtrudi-Zaad and S. E. Salcudean, "Transparency in time-delayed systems and the effect of local force feedback for transparent teleoperation," *IEEE Trans. Robot. Autom.*, vol. 18, no. 1, pp. 108–114, Feb. 2002.
- [98] F. Marcastel, "CERN's accelerator complex. La chaîne des accélérateurs du CERN," CERN, Genève, Switzerland, Tech. Rep. OPEN-PHOCART-2013-001, 2013.
- [99] L. Ducimetière, U. Jansson, G. H. Schroder, E. B. Vossenber, M. J. Barnes, and G. D. Wait, "Design of the injection kicker magnet system for CERN's 14 TeV proton collider LHC," in *10th IEEE Int. Pulsed Power Conf. Dig. Tech. Papers*, vol. 2, Jul. 1995, pp. 1406–1411.
- [100] A. Kellerbauer, "Proposed antimatter gravity measurement with an anti-hydrogen beam," *Nucl. Instrum. Methods Phys. Res. B, Beam Interact. Mater. At.*, vol. 266, no. 3, pp. 351–356, 2008.



MARIO DI CASTRO received the M.Sc. degree in electronic engineering from the University of Naples "Federico II", Italy. From 2007 to 2011, he was with DESY in charge of advanced mechatronics solutions for synchrotron beamlines and industrial controls. Since 2011, he has been with CERN. Since 2018, he leads the Measurements, Robotics and Operation Section, Survey, Mechatronics and Measurements Group. The section is responsible for the design, installation, operation, and maintenance

of control systems on different platforms (PLC, PXI, and VME) for all the equipment under the group's responsibility, mainly movable devices characterized by few μm positioning accuracy (e.g., scrapers, collimators, shielding, and target) in hard radioactive environment. Important section activities are the robotic support in hazardous environments for the whole CERN accelerators. His research interests are mainly focused on automatic controls, mechatronics, motion control in harsh environment, and robotics.



MANUEL FERRE (M'00) received the Laurea degree in control engineering and electronics and the Ph.D. degree in automation and robotics from the Universidad Politécnica de Madrid (UPM), in 1992 and 1997, respectively. He was a Post-Doctoral Researcher with the Human-Machine System Laboratory, Massachusetts Institute of Technology. He is currently a Professor Titular at UPM and the Director of the Centro de Automática y Robótica, UPM. He has participated and coordinated several research projects in robotics and automatic control, both at national and international programs. He has four patents of haptic devices and stereoscopic video cameras. He is author of more than 150 publications. His research interest is focused on automatic control, advanced telerobotics, and Haptics. He is a member of the EuroHaptics Society, euRobotics, and CEA. He has served as the chair of several committees. Currently, he serves as a Treasurer of the EuroHaptics Society and the Chair of the euRobotics Technical Committee on Telerobotics and Teleoperation. He has participated in the organization of several IROS and EuroHaptics conferences. He is the Editor of the *Springer Series on Touch and Haptics System*.

of control systems on different platforms (PLC, PXI, and VME) for all the equipment under the group's responsibility, mainly movable devices characterized by few μm positioning accuracy (e.g., scrapers, collimators, shielding, and target) in hard radioactive environment. Important section activities are the robotic support in hazardous environments for the whole CERN accelerators. His research interests are mainly focused on automatic controls, mechatronics, motion control in harsh environment, and robotics.



ALESSANDRO MASI was born in Napoli, Italy, in 1976. He received the M.D. degree in electronic engineering and the Ph.D. degree in computer science from the University of Napoli Federico II in 2001 and 2005, respectively. His Ph.D. research was carried out at CERN, Group of Magnetic Measurements and Tests, on high-accuracy measurement systems for superconducting magnets of the new particle accelerator, the Large Hadron Collider. In 2005, he was a CERN staff member with

the Sources, Targets and Interactions Group. In 2008, he takes the leadership of the Equipments Controls and Electronic Section. Since 2018, he has been the Head of the Survey, Mechatronics and Measurements (SMM) Group, CERN. The SMM Group develops and maintains a centralized competence in survey, mechatronic systems, test and measurement. The group is in charge of maintaining a competence in the development of radiation tolerant electronics, and provides support CERN wide for radiation tests and radiation monitoring for evaluating the dose to electronics installed in radiation areas. The groups develop robotic platforms adapted to intervention in the accelerator environment, and deploy those solutions in collaboration with all groups in the Accelerator and Technology sector.

• • •