

Received March 31, 2018, accepted May 8, 2018, date of publication May 21, 2018, date of current version June 19, 2018.

Digital Object Identifier 10.1109/ACCESS.2018.2839108

# Cooperative Economic Scheduling for Multiple Energy Hubs: A Bargaining Game Theoretic Perspective

SONGLI FAN<sup>1</sup>, (Student Member, IEEE), ZHENGSHUO LI<sup>2</sup>, (Member, IEEE),  
JIANHUI WANG<sup>3</sup>, (Senior Member, IEEE), LONGJIAN PIAO<sup>4</sup>, (Student Member, IEEE),  
AND QIAN AI<sup>1</sup>, (Senior Member, IEEE)

<sup>1</sup>Department of Electrical Engineering, Shanghai Jiao Tong University, Shanghai 200240, China

<sup>2</sup>Shenzhen Environmental Science and New Energy Technology Engineering Laboratory, Tsinghua-Berkeley Shenzhen Institute, Tsinghua University, Shenzhen 518055, China

<sup>3</sup>Department of Electrical Engineering, Southern Methodist University, Dallas, TX 75275, USA

<sup>4</sup>Faculty of Technology, Policy and Management, Delft University of Technology, 2628 BX Delft, The Netherlands

Corresponding author: Songli Fan (songli\_fan@163.com)

This work was supported by the National Natural Science Foundation of China under Grant 51577115 and Grant U1766207.

**ABSTRACT** Under the background of global energy conservation, the energy hub (EH)-based integrated energy system is becoming the transition direction of future energy structure. In this paper, we study the cooperative economic scheduling problem for multiple neighboring integrated energy systems on the basis of EH. Different with the traditional non-cooperative mode where each EH operates individually, these EHs constitute a cooperative community and can share energy among them. Considering the autonomy and self-interest of different EHs, the coordinated management problem is modeled as a bargaining cooperative game, where involved EHs will bargain with each other about the exchanged energy and the associated payments. The bargaining solution can achieve a fair and Pareto-optimal balance among the objective functions of different EHs. A distributed optimization is applied to find the bargaining solution of the cooperative system, to guarantee the autonomous scheduling and information privacy of EHs. Numerical studies demonstrate the effectiveness of the bargaining-based cooperative economic scheduling framework, and also show the improvement of benefits of the community system.

**INDEX TERMS** Cooperative game, distributed approach, energy hub, energy trading, multiple energy system, Nash bargaining.

## NOMENCLATURE

### A. ACRONYMS

EH	Energy hub
RES	Renewable energy source
EUC	Electricity utility company
GUC	Natural gas utility company
CHP	Combined heat and power unit

### B. INDICES AND SETS

$t, \mathcal{T}$	Index and set for time hours
$i, \mathcal{N}$	Index and set for energy hubs

### C. PARAMETERS

$P_{e,t}^{bg}$	Background electric demand for EUC at time $t$
----------------	--

$P_{g,t}^{bg}$	Background natural gas demand for GUC at time $t$
$\lambda_{e,t}^m$	Wholesale electricity market price at time $t$
$\lambda_{g,t}^m$	Wholesale natural gas market price at time $t$
$\lambda_e^{\min}$	Minimum profit parameter for EUC
$\lambda_g^{\min}$	Minimum profit parameter for GUC
$\kappa_{e,t}, \mu_{e,t}$	Electricity price parameters
$\kappa_{g,t}, \mu_{g,t}$	Natural gas price parameters
$P_{e,i,t}^{RES}$	Renewable outputs of EH $i$ at time $t$
$\eta_{gh}^{gf}$	Thermal generation efficiency of gas furnace
$\eta_{e,i}^s$	Charging/discharging efficiency of electric storage in EH $i$

$\eta_{h,i}^s$	Charging/discharging efficiency of thermal storage in EH $i$
$\eta_{ge}^{chp}, \eta_{gh}^{chp}$	Electric/heat generation efficiency of CHP
$L_{e,i,t}, L_{h,i,t}$	Electric/heat loads of EH $i$ at time $t$
$P_e^{in,max}, P_g^{in,max}$	Maximum transport limits of electricity and natural gas
$P_{e,i}^{chp,min}, P_{e,i}^{chp,max}$	Minimum/maximum electric outputs of CHP in EH $i$
$P_{h,i}^{chp,min}, P_{h,i}^{chp,max}$	Minimum/maximum thermal outputs of CHP in EH $i$
$P_{h,i}^{gf,min}, P_{h,i}^{gf,max}$	Minimum/maximum thermal outputs of gas furnace in EH $i$
$R_{u,i}^{chp}, R_{d,i}^{chp}$	Ramp up/down limits of CHP in EH $i$
$R_{u,i}^{gf}, R_{d,i}^{gf}$	Ramp up/down limits of gas furnace in EH $i$
$P_{e,i}^{ch,max}, P_{e,i}^{dis,max}$	Maximum charging/discharging limits of electric storage in EH $i$
$P_{h,i}^{ch,max}, P_{h,i}^{dis,max}$	Maximum charging/discharging limits of thermal storage in EH $i$
$E_{e,i}^{s,min}, E_{e,i}^{s,max}$	Minimum/maximum energy bounds of electric storage in EH $i$
$E_{h,i}^{s,min}, E_{h,i}^{s,max}$	Minimum/maximum energy bounds of thermal storage in EH $i$
$E_{e,i,0}^s, E_{h,i,0}^s$	Initial energy level of electric storage and thermal storage in EH $i$

**D. VARIABLES**

$P_{e,t}^s$	Total electric demand for EUC at time $t$
$P_{g,t}^s$	Total natural gas demand for GUC at time $t$
$P_{e,i,t}^{in}$	Purchased electricity from EUC by EH $i$ at time $t$
$P_{g,i,t}^{in}$	Purchased natural gas from GUC by EH $i$ at time $t$
$\lambda_{e,t}^{in}$	Retail electricity price at time $t$
$\lambda_{g,t}^{in}$	Retail natural gas price at time $t$
$P_{e,i,t}^{ex}$	Exchanged energy with other EHs by EH $i$ at time $t$
$C_{e,i,t}^{ex}$	Associated exchanging cost for EH $i$ at time $t$
$P_{e,i,t}^{chp}$	Electric power generated by CHP in EH $i$ at time $t$
$P_{h,i,t}^{chp}$	Thermal power generated by CHP in EH $i$ at time $t$
$P_{h,i,t}^{gf}$	Thermal power generated by gas furnace in EH $i$ at time $t$
$\alpha_{i,t}$	Dispatch ratio of natural gas input between CHP and gas furnace in EH $i$ at time $t$
$E_{e,i,t}^s$	Energy level of electric storage in EH $i$ at time $t$

$E_{h,i,t}^s$	Energy level of thermal storage in EH $i$ at time $t$
$S_{e,i,t}^{ch}, S_{e,i,t}^{dis}$	Charging/discharging binary state variable of electric storage in EH $i$ at time $t$
$S_{h,i,t}^{ch}, S_{h,i,t}^{dis}$	Charging/discharging binary state variable of thermal storage in EH $i$ at time $t$
$P_{e,i,t}^{ch}, P_{e,i,t}^{dis}$	Charging/discharging power of electric storage in EH $i$ at time $t$
$P_{h,i,t}^{ch}, P_{h,i,t}^{dis}$	Charging/discharging power of thermal storage in EH $i$ at time $t$

**I. INTRODUCTION**

Nowadays, energy crisis and environmental pollution have made utilizing multiple energy in an integrated way a trend of future energy system [1]–[5]. Meanwhile, the development of combined heating and power (CHP) plants, gas-fired units, and other multi-energy conversion technologies further accelerates this energy structure transition [2], [3]. In a multiple energy system, different forms of energy are interconnected with each other via coupling infrastructures, instead of traditional being operated independently. However, owing to the complexity of energy coupling and the diversity of involved energy devices, great challenges are posed for the coordination and management of the integrated energy system. In this context, energy hub (EH) [4], [5], is proposed to help model and manage the multiple energy system, especially for the distribution-level regional integrated energy system.

In literature, there exist many researches on the optimization and scheduling of multiple energy system on the basis of EH. Specifically, in [6], an optimization approach for multiple buildings was formulated via an EH, where the EH concept was utilized to manage a collection of buildings in a cooperative way. Based on EH, Hao *et al.* [7] proposed a hierarchical optimization model for the small and medium-sized regional multiple energy system, with time-varying tariffs and flexible operating modes. In [8], an optimal operation framework was established for an EH based micro integrated energy system, where the objective was to minimize the total operation cost related to electricity, natural gas, and heat. In [9], the market transaction problem of an EH manager was illustrated, where the EH manager needed to determine the optimal involvement in upstream energy markets, as well as the optimum electricity and heat offering prices to clients. In [10], a day-ahead dynamic optimal operation model was presented for a micro energy grid based on EH concept, and also the real-time pricing problem was considered. However, the study in [6]–[10] mainly focused on the optimal operation/ scheduling/ transaction problem from the perspective of a single EH operator, without considering the interaction with other EHs.

Due to the diversity of configurations and the proximity of locations, it is common that there exist multiple EHs managed by different operators in a region. This may bring a complex business environment for those adjacent EHs.

Specifically, the economic decisions of EHs can be tightly coupled together, as the trading of each individual EH could affect the energy prices in the local market, and further influence the decisions of other EHs. Therefore, it is necessary for an EH operator to consider the impacts from other neighboring EHs when formulating its own economic operation strategy.

Recently, the game-theoretic approaches were commonly adopted to explore the interaction among different EHs. Sheikhi *et al.* [11] and Bahrami and Sheikhi [12] formulated the problem as an ordinal potential game, where each EH locally and selfishly determined its action to minimize its operation cost. The works in [13] and [14] also developed a non-cooperative/ competitive game to address the interaction among EHs, where a Nash equilibrium was found to guarantee the stable optimal operation of EHs. Bahrami *et al.* [15] further extended the works in [11]–[14] with uncertainty about load demand and energy prices, and focused on the competition among multiple EHs using the potential game theoretic approach. In [16], the interaction among multiple parks with various energy flows was also characterized as a non-cooperative game model. Considering the self-interest and information privacy of different EHs, the game theory provides a natural model to study their conflicts and collaborations, in a distributed way [17]. However, the above non-cooperative game theory-based approaches in [11]–[16] are more focused on the independency of EHs, failing to capture the potential cooperation among EHs, and thus usually lead to non-Pareto optimal solutions.

With the popularization of smart devices, different EHs can share some information to achieve the cooperative operation. Through limited information exchange, these EHs may obtain the more favorable retail prices from upstream energy suppliers, compared with that in non-cooperative mode [18]. Moreover, it is possible that these EHs exchange energy among them, due to the diversity of both configurations and demands in different EHs. This can not only increase the operation flexibility of multi-energy systems, but also reduce the waste of surplus energy. Furthermore, it can also bring more benefits for these EHs, compared with only exchanging with the utility companies in non-cooperative mode. Therefore, it is equally important to consider the scenario that involves multiple small autonomous EHs operating in a cooperative fashion, which is considered as an important feature of the future energy business mode [1], [2].

In this paper, we are interested in studying the cooperative interaction of multiple EHs, to explore the coordinated scheduling and energy trades among them. To the best knowledge of the authors, although much research has been devoted to the economic interaction of multiple EHs, little work is available on the cooperative interaction among them. It is assumed that these EHs are autonomous but willing to collaborate together to constitute a cooperative community. They jointly optimize their scheduling and also conduct energy trading among them, by taking the advantages of diverse supply and demand patterns in different EHs. Sim-

ilar to [11]–[16], the upstream energy retail prices are also assumed to be influenced by the total energy demands of EHs in this region. Since EHs can anticipate the impact of their actions on price values, the cooperative scheduling of those EHs may also bring more favorable prices for themselves.

A common approach to optimizing the cooperative coalitions is to minimize the total cost of all participants, through a centralized or hierarchical control structure [19], [20]. However, it always leaves unclear about the associated trading costs (benefits) for each EH should pay (receive). Moreover, some private information of EHs are exposed, which is not desirable for these autonomous EHs. Therefore, this paper intends to study the cooperative interaction problem, from the bargaining game theoretic perspective. The bargaining solution not only can effectively improve the economic performances of these participants, but also can help achieve a fair benefit balance among EHs. Through a distributed optimization approach, the bargaining cooperative problem can be decomposed into local problems for each autonomous EH operator, instead of being controlled by a global operator. This enables those cooperative EHs autonomously coordinate together without exposing their own private information.

The main contributions of this paper are listed as follows:

- We develop a cooperative scheduling model for multiple EHs, where EHs not only coordinate their local operations, but also conduct energy trading with each other.
- We characterize the cooperative interaction among EHs as a bargaining game framework, which can help fairly distribute the surplus benefits among those EHs.
- We utilize a distributed solution to solve the bargaining problem, which can effectively guarantee the autonomous scheduling and information privacy of EHs.

The remainder of this paper is organized as follows: Section II elaborates on the system framework. Section III describes the energy pricing schemes of the upstream suppliers, and also formulates the bargaining cooperative interaction among EHs. Section IV presents a distributed algorithm to solve the bargaining-based model. Section V demonstrates the case studies. Finally, Section VI concludes the paper.

## II. SYSTEM FRAMEWORK

Consider a cooperative community comprised of a set  $\mathcal{N} = \{1, \dots, N\}$  of interconnected EHs as shown in Fig.1, all of which share a common natural gas utility company (GUC) and electricity utility company (EUC). These EHs involve three types of energy: electricity, natural gas, and heat. Different types of energy are coupled by EHs' distributed multi-generation units, including energy conversion, storage, and generation. Here, each EH is assumed to be equipped with the following energy devices: renewable energy source (RES), combined heat and power unit (CHP), gas furnace, electricity storage, and thermal storage. Within the hub, energy is transformed into various forms to meet the users' demands, including electric loads and thermal loads.

Theoretically, an EH can flexibly represent the multi-energy system of arbitrary scale. However, this study only focuses on small-scale EHs, e.g., residential communities, commercial buildings, industrial facilities, etc., so that these neighboring EHs can exchange energy with each other in this cooperative community. In the community, due to the distinction of the power generation and consumption profiles in different EHs, these EHs may act as either energy sellers or buyers depending on their net power profiles. Hence, the energy can be exchanged among these EHs. Belonging to different stakeholders, EHs need to bargain with each other about the exchanged amounts and the associated payments, so that their economic benefits are not jeopardized. In this regard, the cooperation among these EHs is actually a paradigm of transactive interaction, and the cooperative community be seen as a peer-to-peer network (P2P) [21], [22].

To guarantee the autonomy, each EH is assumed to have a local energy management system ( $u$ -EMS). Interiorly, the  $u$ -EMS can send controlling signals to its internal devices and customers, to optimize the operation of the EH. Exteriorly, the  $u$ -EMS can exchange real-time information with other EHs in this cooperative community and the utility companies in the upper level. Therefore, each EH can bargain with other EHs about the traded power and the associated payment. Meanwhile, the EH can also independently buy natural gas and electricity from the outer GUC and EUC at real-time retail prices.

### III. PROBLEM FORMULATION

In this section, we first illustrate the electricity pricing schemes of EUC and GUC, then demonstrate the bargaining game framework of EHs, and finally formulate the bargaining cooperative scheduling model of multiple EHs in this cooperative community.

#### A. ELECTRICITY AND NATURAL GAS PRICING SCHEMES

Considering the retail prices of EUC and GUC will affect the detailed energy purchase schedules of EHs, we first present the electricity and natural gas pricing schemes. As energy intermediaries, the EUC and GUC usually buy energy from the wholesale electricity and natural gas markets, and then sell to energy hub  $i \in \mathcal{N}$  at the retail price  $\lambda_{e,t}^{\text{in}}$  and  $\lambda_{g,t}^{\text{in}}$ . Apart from EHs, the EUC and GUC may also supply background electric and natural gas demands  $P_{e,t}^{\text{bg}}$  and  $P_{g,t}^{\text{bg}}$  for other consumers [15]. Then, the total electricity and natural gas supplied by the EUC and GUC are:

$$\begin{cases} P_{e,t}^{\text{s}} = P_{e,t}^{\text{bg}} + \sum_{i \in \mathcal{N}} P_{e,i,t}^{\text{in}}, & \forall t \in \mathcal{T} \\ P_{g,t}^{\text{s}} = P_{g,t}^{\text{bg}} + \sum_{i \in \mathcal{N}} P_{g,i,t}^{\text{in}}, & \forall t \in \mathcal{T} \end{cases} \quad (1)$$

The corresponding retail prices for EHs  $\lambda_{e,t}^{\text{in}}$  and  $\lambda_{g,t}^{\text{in}}$  depend on both the wholesale market prices and the total energy demands. The detailed dynamic pricing

model is:

$$\begin{cases} \lambda_{e,t}^{\text{in}} = \lambda_e^{\text{min}} + \kappa_{e,t} \lambda_{e,t}^{\text{m}} + \mu_{e,t} P_{e,t}^{\text{in}}, & \forall t \in \mathcal{T} \\ \lambda_{g,t}^{\text{in}} = \lambda_g^{\text{min}} + \kappa_{g,t} \lambda_{g,t}^{\text{m}} + \mu_{g,t} P_{g,t}^{\text{in}}, & \forall t \in \mathcal{T} \end{cases} \quad (2)$$

where  $\lambda_e^{\text{min}}$ ,  $\lambda_g^{\text{min}}$  guarantee the minimum profit margins for the EUC and GUC; parameters  $\kappa_{e,t}$ ,  $\kappa_{g,t}$  scale the wholesale market price  $\lambda_{e,t}^{\text{m}}$  and  $\lambda_{g,t}^{\text{m}}$ , respectively;  $\mu_{e,t}$ ,  $\mu_{g,t}$  represent the linear relationships between the retail prices and total demands. The reasoning details of the dynamic pricing model are available in [15] and omitted here to save space.

According to (1)-(2), EUC and GUC will compute the retail electricity and natural gas prices respectively, and then announce these information to EHs. After receiving the retail prices information, the EH will optimize its internal scheduling (including energy exchanged with other EHs) and transmit its determined energy demands  $P_{e,i,t}^{\text{in}}$ ,  $P_{g,i,t}^{\text{in}}$  to EUC and GUC, respectively.

#### B. BARGAINING GAME AMONG MULTIPLE EHs

In this community, these EHs recognize that they can be better off via cooperation, although they belong to different operators. Different from the individual EH operation, in the cooperative mode, EHs not only can coordinate their local energy supplies and demands, but also can conduct energy trading with each other. Consequently, the cooperation amongst EHs can provide better economic outcome (or reduced operation cost) than being isolated from each other with pure self-interest. However, the critical question for this cooperation is, how should this reduced cost be shared in a fair manner?

A common approach that is used for optimizing a coalition is to minimize the total cost of all participants, from the perspective of a global controller. Nevertheless, this method undermines the autonomy and privacy of the involved EHs; moreover, it may lead to an unequal distribution of the coalition benefits. To solve this challenge, we use the bargaining cooperative game theory-based approach, which can optimize the entire community performance whilst guaranteeing that the surplus profits of cooperation are fairly distributed among those participants [23], [24].

First, we define the payoff of EH  $i$  as  $u_i$  in this bargaining game; meanwhile,  $d_i$  represents the payoff of EH  $i$  when no cooperation is reached, also called the disagreement point. Then, the bargaining-based optimal coordination among EHs can be achieved by solving the following optimization problem:

$$\begin{aligned} & \text{Max} \quad \sum_{i=1}^N \ln(u_i - d_i) \\ & \text{subject to: } u_i \geq d_i, \quad \forall i \in \mathcal{N} \end{aligned} \quad (3)$$

To incentivize players to cooperate with each other, the feasible set of the bargaining game only includes the payoffs which are better than the payoff at the disagreement point. The obtained optimal solution of (3), i.e. Nash bargaining solution (NBS), will achieve an optimal tradeoff between

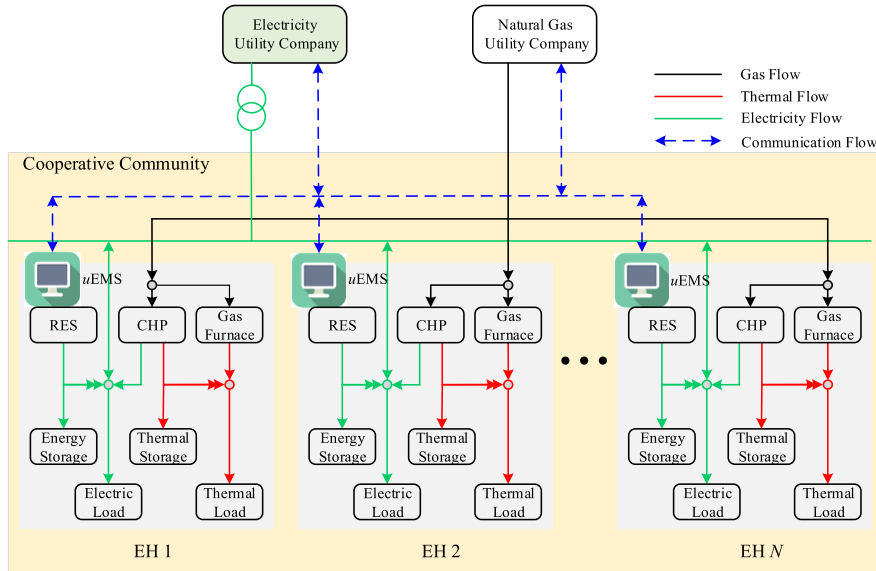

FIGURE 1. Structure of the cooperative community with multiple EHs.

Nash fairness and Nash efficiency, and thus can effectively motivate players to collaborate together [25].

Here, we regard the minus operation cost  $C_i$  of an EH in the time horizon as its payoff, i.e.,  $u_i = -C_i$ ; and the minus non-cooperative operation cost  $C_i^{\text{non}}$  of EH  $i$  as the initial disagreement point, i.e.,  $d_i = -C_i^{\text{non}}$ . Then, the bargaining cooperative model among EHs is transformed into the following form:

$$\begin{aligned} & \text{Max} \sum_{i=1}^N \ln(C_i^{\text{non}} - C_i) \\ & \text{subject to: } C_i \leq C_i^{\text{non}}, \quad \forall i \in \mathcal{N} \end{aligned} \quad (4)$$

where  $C_i^{\text{non}} - C_i$  corresponds to the cost reduction of EH  $i$  through bargaining. In this bargaining cooperative model, each EH attempts to maximize its cost reduction, compared with that in non-cooperative mode.

### C. COOPERATIVE ECONOMIC SCHEDULING MODEL OF EHS

These interconnected EHs constitute a cooperative community where they can share their surplus energy to other deficient EHs to minimize their operation costs. The cost of an EH can be partitioned into three types: electricity purchase cost from EUC, gas purchase cost from GUC, energy trading cost (or revenue) with other EHs. Here, we only consider the electricity exchange among EHs. Denote the amount of electricity exchanged of EH  $i$  as  $P_{e,i,t}^{\text{ex}}$ , and the associated cost is  $C_{e,i,t}^{\text{ex}}$ . If EH  $i$  purchases energy from other EHs at time slot  $t$ , then  $P_{e,i,t}^{\text{ex}} > 0$ , and the corresponding payment  $C_{e,i,t}^{\text{ex}} > 0$ ; otherwise, if EH  $i$  sells electricity to other EHs, then  $P_{e,i,t}^{\text{ex}} < 0$ , and  $C_{e,i,t}^{\text{ex}} < 0$ . The detailed formulation about the cost of EH  $i$  is:

$$C_i = \sum_{t \in \mathcal{T}} \left[ \lambda_{e,t}^{\text{in}} P_{e,i,t}^{\text{in}} + \lambda_{g,t}^{\text{in}} P_{g,i,t}^{\text{in}} + C_{e,i,t}^{\text{ex}} \right] \quad (5)$$

To guarantee the benefits from the community cooperation, EH  $i$  will bargain with other EHs about the trading cost  $C_{e,i,t}^{\text{ex}}$ . As illustrated above, the bargaining-based optimal coordination in this cooperative community can be achieved by solving the following optimization problem:

$$\text{Max} \sum_{i=1}^N \ln \left[ C_i^{\text{non}} - \sum_{t \in \mathcal{T}} \left( \lambda_{e,t}^{\text{in}} P_{e,i,t}^{\text{in}} + \lambda_{g,t}^{\text{in}} P_{g,i,t}^{\text{in}} + C_{e,i,t}^{\text{ex}} \right) \right] \quad (6)$$

Note that, in this bargaining-based objective function, the non-cooperative cost  $C_i^{\text{non}}$  of any EH  $i \in \mathcal{N}$  is regarded as the known input parameter. Meanwhile, it is assumed that each EH  $i \in \mathcal{N}$  would truthfully report its value of  $C_i^{\text{non}}$ , as a prerequisite for joining the cooperative community. The incentive to guarantee this truthful declaration can be achieved by the Vickrey-Clarke-Grove based mechanism, or other faithful mechanisms [26], [27].

Considering the internal balance in this community, the exchanged energy and the associated payments should satisfy the following constraints:

$$\sum_{i \in \mathcal{N}} P_{e,i,t}^{\text{ex}} = 0, \quad \forall t \in \mathcal{T} \quad (7)$$

$$\sum_{i \in \mathcal{N}} C_{e,i,t}^{\text{ex}} = 0, \quad \forall t \in \mathcal{T} \quad (8)$$

Apart from the community-level energy and payment balance, additional constraints within any EH  $i \in \mathcal{N}$  are given below:

$$P_{e,i,t}^{\text{chp}} + P_{e,i,t}^{\text{RES}} + P_{e,i,t}^{\text{dis}} - P_{e,i,t}^{\text{ch}} + P_{e,i,t}^{\text{in}} + P_{e,i,t}^{\text{ex}} = L_{e,i,t}, \quad \forall t \in \mathcal{T} \quad (9)$$

$$P_{h,i,t}^{\text{chp}} + P_{h,i,t}^{\text{gf}} + P_{h,i,t}^{\text{dis}} - P_{h,i,t}^{\text{ch}} = L_{h,i,t}, \quad \forall t \in \mathcal{T} \quad (10)$$

$$P_{e,i,t}^{\text{chp}} = \eta_{\text{gc}}^{\text{chp}} \alpha_{i,t} P_{g,i,t}^{\text{in}}, \quad \forall t \in \mathcal{T} \quad (11)$$

$$P_{h,i,t}^{chp} = \eta_{gh}^{chp} \alpha_{i,t} P_{g,i,t}^{pin}, \quad \forall t \in \mathcal{T} \quad (12)$$

$$P_{h,i,t}^{gf} = \eta_{gh}^{gf} (1 - \alpha_{i,t}) P_{g,i,t}^{pin}, \quad \forall t \in \mathcal{T} \quad (13)$$

$$0 \leq \alpha_{i,t} \leq 1, \quad \forall t \in \mathcal{T} \quad (14)$$

$$0 \leq P_{e,i,t}^{in} \leq P_e^{in,max}, \quad \forall t \in \mathcal{T} \quad (15)$$

$$0 \leq P_{g,i,t}^{in} \leq P_g^{in,max}, \quad \forall t \in \mathcal{T} \quad (16)$$

$$P_{e,i}^{chp,min} \leq P_{e,i,t}^{chp} \leq P_{e,i}^{chp,max}, \quad \forall t \in \mathcal{T} \quad (17)$$

$$P_{h,i}^{chp,min} \leq P_{h,i,t}^{chp} \leq P_{h,i}^{chp,max}, \quad \forall t \in \mathcal{T} \quad (18)$$

$$P_{h,i}^{gf,min} \leq P_{h,i,t}^{gf} \leq P_{h,i}^{gf,max}, \quad \forall t \in \mathcal{T} \quad (19)$$

$$-R_{d,i}^{chp} \Delta t \leq P_{e,i,t+1}^{chp} - P_{e,i,t}^{chp} \leq R_{u,i}^{chp} \Delta t, \quad \forall t \in \mathcal{T} - 1 \quad (20)$$

$$-R_{d,i}^{gf} \Delta t \leq P_{h,i,t+1}^{gf} - P_{h,i,t}^{gf} \leq R_{u,i}^{gf} \Delta t, \quad \forall t \in \mathcal{T} - 1 \quad (21)$$

$$0 \leq P_{e,i,t}^{ch} \leq S_{e,i,t}^{ch} P_{e,i}^{ch,max}, \quad \forall t \in \mathcal{T} \quad (22)$$

$$0 \leq P_{h,i,t}^{ch} \leq S_{h,i,t}^{ch} P_{h,i}^{ch,max}, \quad \forall t \in \mathcal{T} \quad (23)$$

$$0 \leq P_{e,i,t}^{dis} \leq S_{e,i,t}^{dis} P_{e,i}^{dis,max}, \quad \forall t \in \mathcal{T} \quad (24)$$

$$0 \leq P_{h,i,t}^{dis} \leq S_{h,i,t}^{dis} P_{h,i}^{dis,max}, \quad \forall t \in \mathcal{T} \quad (25)$$

$$0 \leq S_{e,i,t}^{ch} + S_{e,i,t}^{dis} \leq 1, \quad \forall t \in \mathcal{T} \quad (26)$$

$$0 \leq S_{h,i,t}^{ch} + S_{h,i,t}^{dis} \leq 1, \quad \forall t \in \mathcal{T} \quad (27)$$

$$E_{e,i,t+1}^s = E_{e,i,t}^s + P_{e,i,t+1}^{ch} \eta_{e,i}^s - P_{e,i,t+1}^{dis} / \eta_{e,i}^s, \quad \forall t \in \mathcal{T} - 1 \quad (28)$$

$$E_{h,i,t+1}^s = E_{h,i,t}^s + P_{h,i,t+1}^{ch} \eta_{h,i}^s - P_{h,i,t+1}^{dis} / \eta_{h,i}^s, \quad \forall t \in \mathcal{T} - 1 \quad (29)$$

$$E_{e,i}^{s,min} \leq E_{e,i,t}^s \leq E_{e,i}^{s,max}, \quad \forall t \in \mathcal{T} \quad (30)$$

$$E_{h,i}^{s,min} \leq E_{h,i,t}^s \leq E_{h,i}^{s,max}, \quad \forall t \in \mathcal{T} \quad (31)$$

$$E_{e,i,T}^s = E_{e,i,0}^s \quad (32)$$

$$E_{h,i,T}^s = E_{h,i,0}^s \quad (33)$$

In the above formulations, constraints (9) and (10) are the electric and thermal power balance equations of EH  $i$ , respectively. Constraints (11)-(13) characterize the energy conversion relationships of CHP and gas furnace, respectively. Constraint (14) imposes the bounds of natural gas ratio input to CHP in EH  $i$ . Constraints (15) and (16) restrict that the input electric and gas power from EUC and GUC for EH  $i$  are within the allowable capacities, respectively. Constraints (17)-(19) guarantee that electric and thermal power outputs of CHP and gas furnace are within the generation capacities. Constraints (20)-(21) represent the ramp up and down limits. Constraints (22)-(25) are the charging and discharging limits of electric storage and thermal storage. Constraints (26)-(27) enforce the constraints about binary state variables of energy storage and thermal storage, which require that the charging and the discharging states of a storage are mutually exclusive. Constraints (28)-(29) express the electric and thermal energy level dynamics of electric storage and thermal storage, respectively. Constraints (30)-(31) signify the bounds of stored electric and thermal energy in electric and thermal

storage, respectively. Constraints (32)-(33) require that the electric and thermal storages have the same energy level at the beginning and the end of scheduling horizon.

#### IV. DISTRIBUTED SOLUTION

In this section, we utilize a decentralized optimization method to solve the bargaining cooperative problem, which enables the EHs in this community to coordinate with each other, without exposing their own private information. The alternating direction method of multipliers (ADMM) [28] is introduced to design the distributed approach, as ADMM has good convergence properties for the optimization problems with non-strictly convex objective functions.

##### A. PROBLEM DECOMPOSITION

In this bargaining cooperative problem (6)-(33), constraints (9)-(33) can be separated into each EH; however, the community-level constraints (7)-(8) couple all EHs together. In order to decouple each EH's exchanged power variables and the associated payment variables, we introduce auxiliary variables:

$$\hat{P}_{e,i,t}^{ex} = P_{e,i,t}^{ex}, \quad \forall t \in \mathcal{T}, \forall i \in \mathcal{N} \quad (34)$$

$$\hat{C}_{e,i,t}^{ex} = C_{e,i,t}^{ex}, \quad \forall t \in \mathcal{T}, \forall i \in \mathcal{N} \quad (35)$$

By enforcing consensus constraints as in (34)-(35), the bargaining cooperative problem can be rewritten as:

$$\begin{aligned} & \text{Max} \sum_{i=1}^N \ln \left[ C_i^{\text{non}} - \sum_{t \in \mathcal{T}} \left( \lambda_{e,t}^{\text{in}} P_{e,i,t}^{\text{pin}} + \lambda_{g,t}^{\text{in}} P_{g,i,t}^{\text{pin}} + C_{e,i,t}^{\text{ex}} \right) \right] \\ & \text{subject to: } \hat{P}_{e,i,t}^{\text{ex}} = P_{e,i,t}^{\text{ex}}, \quad \forall t \in \mathcal{T}, \forall i \in \mathcal{N} \\ & \quad \hat{C}_{e,i,t}^{\text{ex}} = C_{e,i,t}^{\text{ex}}, \quad \forall t \in \mathcal{T}, \forall i \in \mathcal{N} \\ & (7) - (33) \\ & \text{variables: } \left\{ \begin{array}{l} \hat{P}_{e,i,t}^{\text{ex}}, \hat{C}_{e,i,t}^{\text{ex}}, P_{e,i,t}^{\text{ex}}, C_{e,i,t}^{\text{ex}}, P_{e,i,t}^{\text{pin}}, P_{g,i,t}^{\text{pin}}, P_{e,i,t}^{\text{chp}}, \\ P_{e,i,t}^{\text{dis}}, P_{e,i,t}^{\text{ch}}, P_{h,i,t}^{\text{chp}}, P_{h,i,t}^{\text{gf}}, P_{h,i,t}^{\text{dis}}, P_{h,i,t}^{\text{ch}}, \\ \forall t \in \mathcal{T}, \quad \forall i \in \mathcal{N} \end{array} \right\} \end{aligned} \quad (36)$$

The augmented Lagrangian function for the bargaining cooperation objective is:

$$\begin{aligned} L &= \sum_{i \in \mathcal{N}} - \ln \left[ C_i^{\text{non}} - \sum_{t \in \mathcal{T}} \left( \lambda_{e,t}^{\text{in}} P_{e,i,t}^{\text{pin}} + \lambda_{g,t}^{\text{in}} P_{g,i,t}^{\text{pin}} + C_{e,i,t}^{\text{ex}} \right) \right] \\ &+ \sum_{i \in \mathcal{N}} \sum_{t \in \mathcal{T}} \left[ \lambda_{i,t} \left( \hat{P}_{e,i,t}^{\text{ex}} - P_{e,i,t}^{\text{ex}} \right) + \frac{\rho_1}{2} \left( \hat{P}_{e,i,t}^{\text{ex}} - P_{e,i,t}^{\text{ex}} \right)^2 \right] \\ &+ \sum_{i \in \mathcal{N}} \sum_{t \in \mathcal{T}} \left[ \gamma_{i,t} \left( \hat{C}_{e,i,t}^{\text{ex}} - C_{e,i,t}^{\text{ex}} \right) + \frac{\rho_2}{2} \left( \hat{C}_{e,i,t}^{\text{ex}} - C_{e,i,t}^{\text{ex}} \right)^2 \right] \end{aligned} \quad (37)$$

where  $\lambda_{i,t}$ ,  $\gamma_{i,t}$  are the Lagrangian multipliers, and  $\rho_1 > 0$ ,  $\rho_2 > 0$  are penalty parameters, corresponding to constraints (34), (35) respectively.

By using the ADMM decomposition technique, the problem (36) can be decomposed into the lower-level subproblem for each EH and the upper-level subproblem for a virtual coordinator. The lower-level subproblem involves EHs solving their local optimization problems in parallel based on fixed dual variables  $\lambda_{i,t}$ ,  $\gamma_{i,t}$  and auxiliary variables  $\hat{P}_{e,i,t}^{\text{ex}}$ ,  $\hat{C}_{e,i,t}^{\text{ex}}$ . The upper-level subproblem involves the virtual coordinator updating the auxiliary variables and dual variables using the results from the lower-level EH problems.

Responsible for information exchanges and information updates, the virtual coordinator does not control any energy components in EHs. Generally, the virtual coordinator is a non-profit driven computing module, which can be served by the community-level cyber network [29], or public cloud computing center [13], etc. Resorting to the smart communication technologies, the virtual coordinator can communicate with all participating EHs in this cooperative community. In order to keep fairness, the virtual coordinator also should not have any tendency.

Specifically, the subproblem for each EH is formulated as:

$$\begin{aligned} \text{Min} \quad & -\ln \left[ C_i^{\text{non}} - \sum_{t \in \mathcal{T}} \left( \lambda_{e,t}^{\text{in}} P_{e,i,t}^{\text{in}} + \lambda_{g,t}^{\text{in}} P_{g,i,t}^{\text{in}} + C_{e,i,t}^{\text{ex}} \right) \right] \\ & + \sum_{t \in \mathcal{T}} \left[ -\lambda_{i,t} P_{e,i,t}^{\text{ex}} + \frac{\rho_1}{2} \left( \hat{P}_{e,i,t}^{\text{ex}} - P_{e,i,t}^{\text{ex}} \right)^2 \right] \\ & + \sum_{t \in \mathcal{T}} \left[ -\gamma_{i,t} C_{e,i,t}^{\text{ex}} + \frac{\rho_2}{2} \left( \hat{C}_{e,i,t}^{\text{ex}} - C_{e,i,t}^{\text{ex}} \right)^2 \right] \\ \text{subject to:} \quad & (9) - (33) \\ \text{variables:} \quad & \left\{ \begin{array}{l} P_{e,i,t}^{\text{ex}}, C_{e,i,t}^{\text{ex}}, P_{e,i,t}^{\text{in}}, P_{g,i,t}^{\text{in}}, P_{e,i,t}^{\text{chp}}, P_{e,i,t}^{\text{dis}}, \\ P_{e,i,t}^{\text{pch}}, P_{h,i,t}^{\text{chp}}, P_{h,i,t}^{\text{p}^{\text{gf}}}, P_{h,i,t}^{\text{dis}}, P_{h,i,t}^{\text{pch}}, \quad \forall t \in \mathcal{T} \end{array} \right\} \end{aligned} \quad (38)$$

And the subproblem for the virtual coordinator is:

$$\begin{aligned} \text{Min} \quad & \sum_{i \in \mathcal{N}} \sum_{t \in \mathcal{T}} \left[ \lambda_{i,t} \hat{P}_{e,i,t}^{\text{ex}} + \frac{\rho_1}{2} \left( \hat{P}_{e,i,t}^{\text{ex}} - P_{e,i,t}^{\text{ex}} \right)^2 \right] \\ & + \sum_{i \in \mathcal{N}} \sum_{t \in \mathcal{T}} \left[ \gamma_{i,t} \hat{C}_{e,i,t}^{\text{ex}} + \frac{\rho_2}{2} \left( \hat{C}_{e,i,t}^{\text{ex}} - C_{e,i,t}^{\text{ex}} \right)^2 \right] \\ \text{subject to:} \quad & \sum_{i \in \mathcal{N}} \hat{P}_{e,i,t}^{\text{ex}} = 0, \quad \forall t \in \mathcal{T} \\ & \sum_{i \in \mathcal{N}} \hat{C}_{e,i,t}^{\text{ex}} = 0, \quad \forall t \in \mathcal{T} \\ \text{variables:} \quad & \left\{ \hat{P}_{e,i,t}^{\text{ex}}, \hat{C}_{e,i,t}^{\text{ex}}, \forall t \in \mathcal{T}, \forall i \in \mathcal{N} \right\} \end{aligned} \quad (39)$$

### B. ALGORITHM IMPLEMENTATION

The detailed procedure for the distributed algorithm to achieve NBS is elaborated in Algorithm 1. First, each EH  $i \in \mathcal{N}$  solves the local problem (38) in parallel, to obtain the optimal solution  $\{P_{e,i}^{\text{ex}}, C_{e,i}^{\text{ex}}, P_{e,i}^{\text{in}}, P_{g,i}^{\text{in}}, P_{e,i}^{\text{chp}}, P_{e,i}^{\text{dis}}, P_{e,i}^{\text{pch}}, P_{h,i}^{\text{chp}}, P_{h,i}^{\text{p}^{\text{gf}}}, P_{h,i}^{\text{dis}}, P_{h,i}^{\text{pch}}\}$ . Then it sends the values of  $P_{e,i}^{\text{ex}}, C_{e,i}^{\text{ex}}$  to the virtual coordinator. Virtual coordinator, after receiving the update values of  $P_{e,i}^{\text{ex}}, C_{e,i}^{\text{ex}}$  from all EHs, solves the

optimization problem in (39) to obtain the optimal solution  $\{\hat{P}_{e,i}^{\text{ex}}, \hat{C}_{e,i}^{\text{ex}}\}$ . Based on the current values of  $P_{e,i}^{\text{ex}}, \hat{P}_{e,i}^{\text{ex}}, C_{e,i}^{\text{ex}}, \hat{C}_{e,i}^{\text{ex}}$ , the virtual coordinator updates the dual variables in Algorithm 1, and then send the values  $\hat{P}_{e,i}^{\text{ex}}, \hat{C}_{e,i}^{\text{ex}}, \lambda_i, \gamma_i$  to the corresponding EHs. Meanwhile, the penalty parameters  $\rho_1, \rho_2$  can be updated as diminishing stepsizes, e.g.,  $\rho_1^{[k]} = 1/k, \rho_2^{[k]} = 1/k$ , to achieve a faster convergence [28].

Note that Algorithm 1 only requires limited information exchanges between the upper-level virtual coordinator and the lower-level EHs. Such communication can be supported by many existing one-to-many communication technologies, e.g., LTE cellular technology. For the EHs, they only need to report their energy exchanged and payment schedules in this cooperative community, without disclosing their private information on internal operations. Therefore, Algorithm 1 can effectively protect the information privacy of all involved EHs.

### Algorithm 1 Distributed Energy Trading Algorithm

- 1: Initialize:  $k = 0, \lambda_i = 0, \gamma_i = 0, \forall i \in \mathcal{N}$
- 2: **repeat**
- 3:   **At each EH:**
- 4:   **repeat**
- 5:     wait
- 6:   **until** receive the updated  $\lambda_i, \hat{P}_{e,i}^{\text{ex}}, \gamma_i, \hat{C}_{e,i}^{\text{ex}}$  from the virtual coordinator
- 7:   1) solve local problem in (38) for the optimal solution  $\{P_{e,i}^{\text{ex}}, C_{e,i}^{\text{ex}}, P_{e,i}^{\text{in}}, P_{g,i}^{\text{in}}, P_{e,i}^{\text{chp}}, P_{e,i}^{\text{dis}}, P_{e,i}^{\text{pch}}, P_{h,i}^{\text{chp}}, P_{h,i}^{\text{p}^{\text{gf}}}, P_{h,i}^{\text{dis}}, P_{h,i}^{\text{pch}}\}$
- 8:   2) send  $P_{e,i}^{\text{ex}}, C_{e,i}^{\text{ex}}$  to the virtual coordinator
- 9:   **At the virtual coordinator:**
- 10:   **repeat**
- 11:     wait
- 12:   **until** receives updated  $P_{e,i}^{\text{ex}}, C_{e,i}^{\text{ex}}$  from all EHs
- 13:   1) solve the problem in (39) for optimal solution  $\{\hat{P}_{e,i}^{\text{ex}}, \hat{C}_{e,i}^{\text{ex}}, \forall i \in \mathcal{N}\}$
- 14:   2) update dual variables:
 
$$\lambda_i^{[k+1]} = \lambda_i^{[k]} + \rho_1 \left( \hat{P}_{e,i}^{\text{ex}[k+1]} - P_{e,i}^{\text{ex}[k+1]} \right)$$

$$\gamma_i^{[k+1]} = \gamma_i^{[k]} + \rho_2 \left( \hat{C}_{e,i}^{\text{ex}[k+1]} - C_{e,i}^{\text{ex}[k+1]} \right)$$
- 15:   3) send  $\hat{P}_{e,i}^{\text{ex}}, \hat{C}_{e,i}^{\text{ex}}, \lambda_i, \gamma_i$  to corresponding EH
- 16:   **update** iteration index  $k = k + 1$
- 17:   **until** terminal condition is satisfied, i.e.,
 
$$\sum_{i=1}^N \left\| \hat{P}_{e,i}^{\text{ex}[k+1]} - P_{e,i}^{\text{ex}[k+1]} \right\| \leq \epsilon_1, \quad \sum_{i=1}^N \left\| \hat{C}_{e,i}^{\text{ex}[k+1]} - C_{e,i}^{\text{ex}[k+1]} \right\| \leq \epsilon_2$$
- 18:   **end**

## V. CASE STUDIES

### A. Test Systems

To evaluate the proposed formulation, a regional test system with four interconnected EHs is considered, where all EHs are in the residential area and commonly served by one EUC and one GUC. For EUC and GUC, we set their background demands of other consumers to  $P_{e,t}^{\text{bg}} = P_{g,t}^{\text{bg}} = 0$ , as done

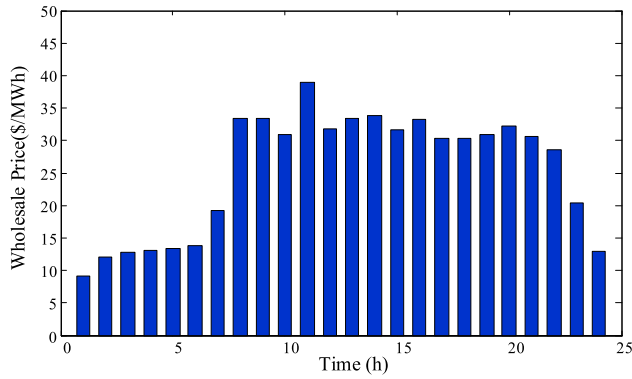

FIGURE 2. Electricity wholesale market prices.

TABLE 1. Technical parameters of controllable devices in each EH.

$P_e^{chp,max}, P_e^{chp,min}$ (kW)	$P_h^{chp,max}, P_h^{chp,min}$ (kW)	$R_d^{chp}, R_u^{chp}$ (kW/h)	$\eta_{ge}^{chp}, \eta_{gh}^{chp}$ 35%, 45.5%
200, 0	260, 0	100, 100	
$P_h^{ef,max}, P_h^{ef,min}$ (kW)	—	$R_d^{ef}, R_u^{ef}$ (kW/h)	$\eta_{gh}^{ef}$ 90%
200, 0	—	100, 100	
$E_e^{s,cap}, E_e^{s,0}$ (kWh)	$E_e^{s,max}, E_e^{s,min}$ (kWh)	$P_e^{ch,max}, P_e^{dis,max}$ (kW)	$\eta_e^s$ 95%
200, 100	180, 40	50, 50	
$E_h^{s,cap}, E_h^{s,0}$ (kWh)	$E_h^{s,min}, E_h^{s,max}$ (kWh)	$P_h^{ch,max}, P_h^{dis,max}$ (kW)	$\eta_h^s$ 95%
100, 50	90, 20	30, 30	

in [15]. Meanwhile, the wholesale electricity and natural gas prices are adopted from [30], as shown in Fig.2. The natural gas wholesale price is set to 19 \$/MWh (during the transformation, the low heating value of natural gas is 9.7 kWh/m<sup>3</sup>). Parameters  $\lambda_e^{min}, \lambda_g^{min}$  are set to 20% of the corresponding wholesale prices, respectively. Parameters  $\kappa_{e,t}, \kappa_{g,t}$  are both set to 1; and parameters  $\mu_{e,t}, \mu_{g,t}$  are set to 5 \$/MWh and 0.5 \$/MWh, respectively.

Each EH's structure is the same as shown in Fig.1. Owing energy generation, conversion and storage equipments, each EH can independently schedule its internal units or trade with external business entities to meet its local electric and thermal loads. The daily electric and thermal load curves of the four EHs are depicted in Fig.3 (a) and (b), respectively. The renewable power profiles of different EHs are shown in Fig.4. The technique parameters of the controllable devices, including CHP plant, gas furnace, electricity storage, and thermal storage, are assumed to be the same for all EHs. The detailed technical data of those energy infrastructures are tabulated in Table 1. Note that, the CHPs in this study are assumed to operate at the fixed electricity-to-heat ratio, and here the ratio is 1.3. In addition, it is assumed that the maximum transmission capabilities of electricity and natural gas for all EH are also the same, i.e.,  $P_e^{in,max} = 500$  kW,

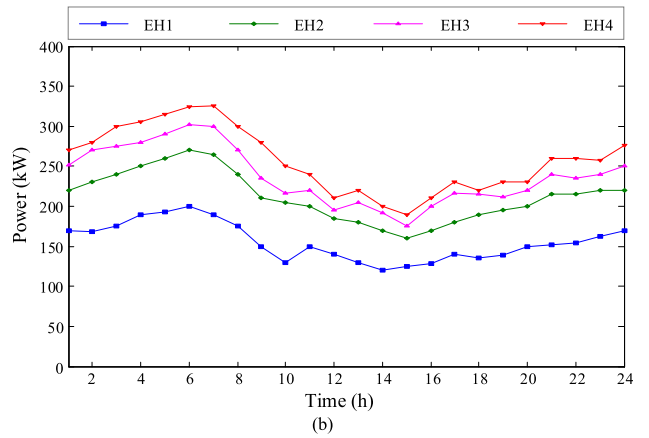
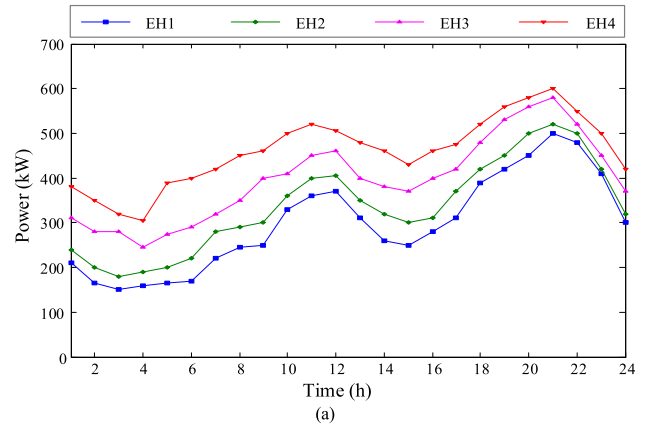

FIGURE 3. Daily load curves of four EHs in the test system. (a) Daily electric load curves of EHs. (b) Daily thermal load curves of EHs.

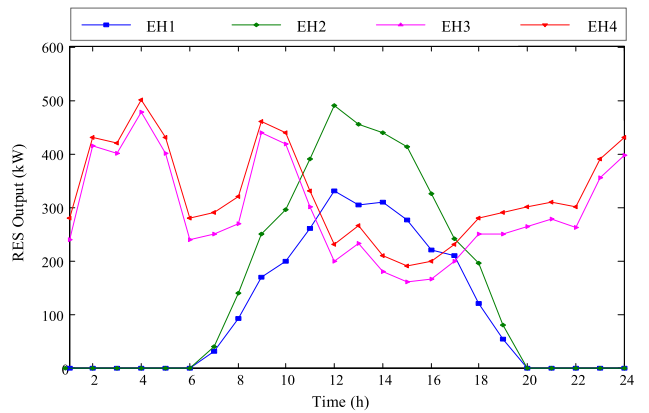

FIGURE 4. Renewable outputs of EHs.

$P_g^{in,max} = 450$  kW. All tests are conducted on a Windows 10 64-bit personal computer with Intel Core i5-3570 3.4 GHz CPU and 16 GB of RAM using Matlab with Yalmip and Gurobi.

### B. Results and Discussion

We first compare the total electricity demands from EHs and the corresponding electricity retail prices of EUC, when the studied EHs operate under the cooperative and non-



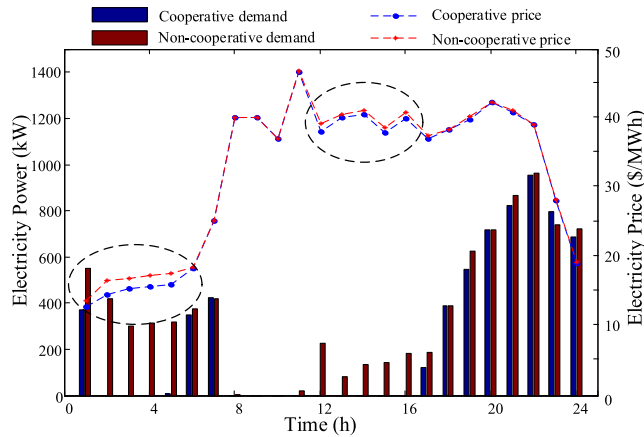

FIGURE 5. Total electricity demand and price for EUC.

cooperative modes, as depicted in Fig.5. Subject to the volatility of electricity wholesale market prices, the electricity retail price also changes relatively violently, according to Fig.5. At high-price hours, the total electricity demands from EH clusters are relatively lower. Meanwhile, the internal energy trading among EHs further lowers the electricity purchased from external EUC, compared with the scenario where each EH individually operates. As shown in Fig.5, the total demanded power drops during hours 1-6 and 12-17, when most of energy exchange among EHs occurs. This is because EHs with excess energy can sell to other EHs using more attractive prices, and that promotes the internal trading among EHs. Due to the linear relationship between the retail price and electricity demand, the electricity retail price also declines with the reduction of the corresponding total demand. Therefore, it is reasonable to conclude that the cooperative scheduling of EHs not only promotes their community-level internal trade, but also may bring more favorable retail prices for them.

Figure 6 provides the comparison of total gas demands from EHs and the corresponding gas price of GUC, under the cooperative and non-cooperative modes. Not like the electricity retail price, the change of natural gas retail prices across the whole horizon is not obvious, as presented in Fig.6, just fluctuating between the interval [19.7, 20.1]. This is mainly because the thermal loads in EHs only can be satisfied by consuming natural gas, resulting in the relatively stable gas demands regardless of the cooperative or non-cooperative modes. On the other side, it also partially attributes to the small value of the scale factor  $\mu_{g,t}$ , but the effect is very tiny. Meanwhile, we can notice that the natural gas retail prices do not show the similar trend as done by electricity prices; specifically, the natural gas retail prices in the cooperative mode are not always smaller than those in the non-cooperative mode. It can be inferred that the cooperation among EHs does not reduce EHs' demands for natural gas as done for electricity. Instead, during hours 8, 11-13, 16-18, the natural gas demands from EH clusters increase, with different increments. Accordingly, the natural gas retail

prices determined by GUC also grow higher, in the cooperative mode. This is because, during these hours, it is more economically efficient for EHs to purchase natural gas to generate energy by their own generation devices, instead of directly buying electricity from EUC. This is just the demonstration of the integrated demand response proposed in [13], i.e., from the customer side's viewpoint, the electricity consumption is not reduced, but the source of supplying electricity has been switched to natural gas. In addition, it is also reasonable to infer that the cooperation further improves the utilization of devices in EHs, since the increased gas demands are only consumed by internal CHP or gas furnace in EHs.

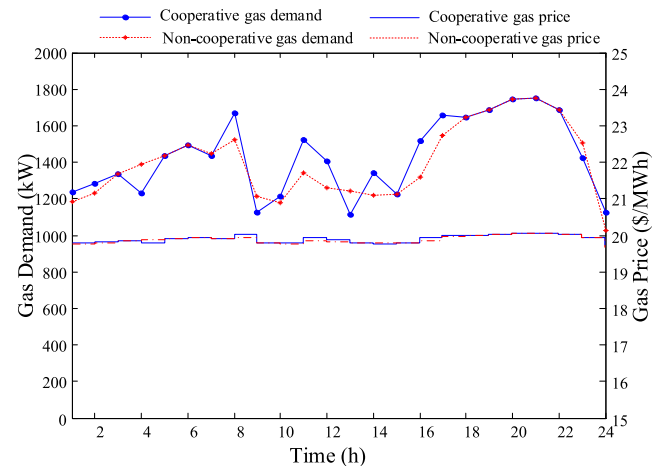

FIGURE 6. Total natural gas demand and price for GUC.

Furthermore, Fig.7 depicts the natural gas dispatch factor  $\alpha$  curve of EH3, in both cooperative and non-cooperative mode. During hours 1-7, the proportion of CHP's gas consumption is relatively small; whereas, during hours 11-23, the ratio increases remarkably. These findings are understandable because, the electricity prices at hours 1-7 are lower than the natural gas price (see Fig.2), the gas consumptions are mainly used to meet the local thermal loads. Given that the thermal conversion efficiency of gas furnace is higher than that of CHP, it is reasonable that the gas furnace is assigned with more inputs of natural gas. On the contrary, during hours 11-23, the electricity prices are apparently higher than the gas prices, the EH prefers to utilize the natural gas to generate electricity by itself. Accordingly, the gas dispatch ratio to CHP is pretty high to maximize the electricity outputs of CHP to meet its electric loads. This further demonstrates the aforementioned effect of the integrated demand response. Note that, the above performance is more obvious in the non-cooperative mode, especially during hours 12-16. This is because, in the non-cooperative mode, the EH only interact with upstream utility companies to optimize its scheduling; on the contrast, in the cooperative mode, the EH can exchange electricity with other EHs, which reduces the reliance on its CHP units. Therefore, the CHP's gas consumption ratio in the cooperative mode decreases at some slots, such as at hour 4-5, and hours 12-16.

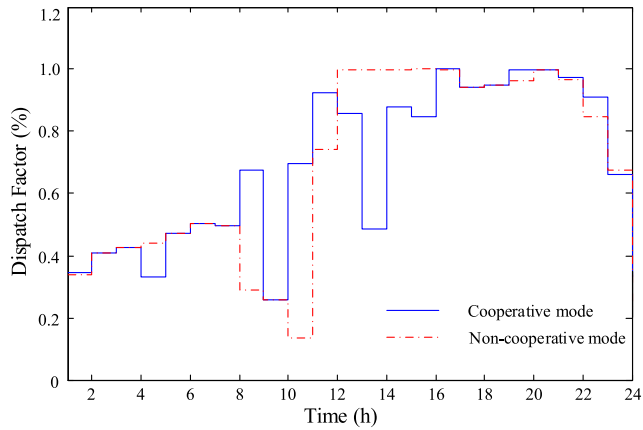

FIGURE 7. Dispatch factor for CHP in EH3.

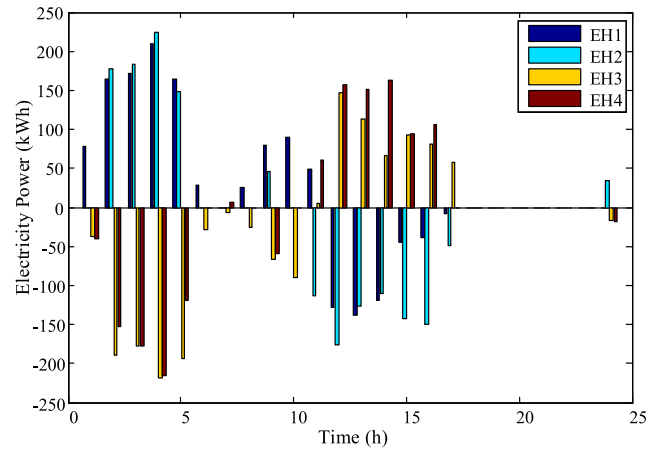

FIGURE 9. Energy trading among EHs in cooperative framework.

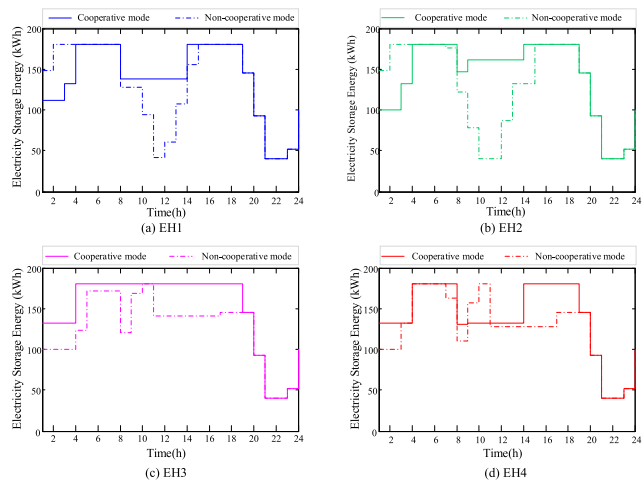

FIGURE 8. Electrical storage energy changes of EHs.

Figure 8 provides the details on energy levels of electrical storages in the studied four EHs. In the non-cooperative mode, the energy levels in both EH1's and EH2's storages decline continuously during hours 8-12, resulting from the power discharging. This is because, the EHs prefer to utilize their own energy devices to meet the local demands, with the increase of electricity wholesale market price. In other words, during high-price hours, it is more cost-effective for EH1 and EH2 to dispatch their storages, rather than purchase energy directly from the external market. On the contrary, in the cooperative mode, the discharge depths in EH1's and EH2's electrical storages during hours 8-12 diminish. Meanwhile, this cooperation helps EH1 and EH2 to reduce the frequent charge/discharge actions on their electric storages, which is conducive to the lifetimes of storages. This demonstrates that, the cooperative interaction enable EH1 and EH2 to reduce their original dependencies on their own electrical storages. Furthermore, it can be inferred that EH1 and EH2 may buy energy from EH3 and/or EH4 during hours 8-12, which can be verified by the following results on energy trades among EHs.

Notably, the stored energy in EH3 and EH4 may not be necessarily reduced as shown in Fig.8, although they sell energy during these hours. In fact, only EH4 reduces its original charging power at hours 9-11. This is because, the cooperative mode also changes the operations of CHP units in EHs, and further influences the total generated electricity in the whole community. It is possible that the CHP in EH3 generates more electricity to sell to other EHs and also to charge its own storage. This is highly consistent with the change of dispatch factor for CHP in EH3 as illustrated in Fig.7. Consequently, the energy level of the electrical storage in EH3 does not decline like EH4 does, but instead increase after cooperation. Similarly, the thermal storages in these EHs also operate in different energy levels under the cooperative and non-cooperative modes. For sake of simplicity and to focus on the cooperative energy trade among EHs, we do not include a detailed analysis of the operation results of thermal storages. However, such detailed representation can be easily incorporated.

The optimal electricity energy trades among these four EHs in this bargaining cooperative framework are depicted in Fig.9. Here, positive values represent purchasing energy, and negative values correspond to selling energy. We can see that, during night (mainly referring to hours 1-5), both EH1 and EH2 purchase energy from EH3 and EH4, while they sell energy to EH3 and EH4 during daytime (mainly referring to hours 11-17). This is because the renewable outputs of EH1 and EH2 mainly occur at the daytime (see Fig.4), which are higher than their local electricity loads, and thus EH1 and EH2 have excess energy to sell to other EHs. On the contrary, EH3 and EH4 have surplus energy mostly during hours 1-5, and hence they act as the role of seller during night. Differently, during hours 18-24, these EHs scarcely exchange any energy. This is because during these hours, almost none of these EHs have surplus energy to be shared in this cooperative community. Instead, they may need to discharge their storages and purchase energy from EUC to meet their local loads. This is also the reason that,

**TABLE 2. Costs and parameters under different modes.**

	EH1	EH2	EH3	EH4	System
Operation cost (Non-cooperative mode)	208.85	236.90	230.07	259.06	934.88
Operation cost (Cooperative mode)	199.99	236.32	213.82	233.36	883.49
Payment (for internal trading)	-3.98	-12.27	3.40	12.85	0
Net cost (Cooperative mode)	196.01	224.05	217.22	246.21	883.49

the electric storages in EH1-EH4 are all in the discharge states as shown in Fig.8, and the total demands at hours 18-24 are relative high as shown in Fig.5. These results indicate that the cooperative interaction among EHs can effectively improve the internal trade among EHs according to their net energy.

Table 2 tabulates the operating costs of EH 1-4 and their payments for energy trading. The total cost of these four EHs declines by up to 5.5% from 934.88 \$ to 883.49 \$. We see that the cooperative mode reduces the operating costs of all EHs. This is because the internal trading reduces the external retail price, and it decreases those EHs' purchasing costs from EUC. Meanwhile, since EH1 and EH2 contribute more in this cooperative mode, they receive additional payments from EH3 and EH4. Considering the overall impact of cost and payment, every EH benefits from the internal trading. For example, EH1 reduces the net operation cost from 208.85 \$ (non-cooperative mode) to 196.01 \$ (operation cost in cooperative mode plus payment), with a decrease of 6.15%. This demonstrates the effectiveness of the proposed bargaining scheme, which incentivizes EHs to participate in the cooperative mode.

**TABLE 3. Comparison between the centralized and distributed approaches.**

Types	Centralized approach	Distributed approach
EH1 cost (\$)	196.00	196.01
EH2 cost (\$)	224.07	224.05
EH3 cost (\$)	217.22	217.22
EH4 cost (\$)	246.23	246.21
Total cost (\$)	883.52	883.49
Computation time (s)	4.87	25.16

To analyze the accuracy of the distributed solution used in this paper, we compare the results of the centralized approach and distributed approach in Table 3. Here, the net operation costs (plus internal trading payment) of EHs in the cooperative mode, as well as the computation time, are presented. It is shown that the difference of the cost results under these two approaches is fairly small, but the computation speed of the distributed approach is slower than that of the centralized one. That means, the autonomy of EHs' decision making is achieved almost without sacrificing the economic performance (or optimality in terms of cost), yet this is at the cost of more computational time. This is because, in the distributed

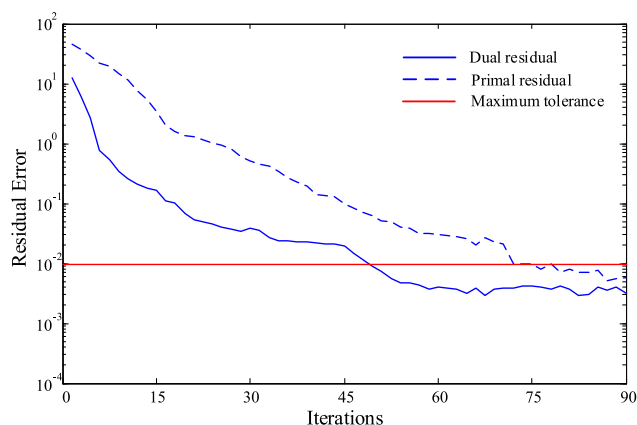
**FIGURE 10. Convergence of the primal and dual residuals in the distributed approach.**

approach, each EH will operate autonomously, and all EHs will be coordinated by a virtual coordinator. Correspondingly, iterations are needed to guarantee all EHs converge to an equilibrium state. In contrast, in the centralized approach, there exists a global controller to fully control the operation schedule of all EHs, and thus there is no need to conduct the iteration process.

Specifically, the semilog curves of the primal and dual residuals with the change of iterations in this distributed algorithm are depicted in Fig.10. After about 75 iterations, the primal and dual residuals both reach the maximum error tolerance, which indicates the solutions of the distributed algorithm satisfy the constraints in this cooperative model and achieve the optimality. To be noted that, only when the primal and dual residuals both reach the maximum error tolerance, the solutions are regarded to satisfy the convergence condition. In this regard, although the dual residual has reached the tolerance in earlier iterations, the iteration process is also needed to ensure the primal residual finally close to the convergence precision.

## VI. CONCLUSIONS

In this paper, a cooperative scheduling framework has been proposed for multiple neighboring EHs, who are commonly served by one EUC and GUC. With different supply and load patterns, these cooperative EHs can exchange power rationally, to minimize their own operational costs. To guarantee all EHs are effectively incentivized to cooperate together, the bargaining game theory is utilized to help achieve a fair and Pareto solution of the optimization problem. Simulation results demonstrate that the cooperative operation of multi-EH has better economic benefits than the non-cooperative operation. Meanwhile, the utilization of distributed approach ensures the autonomous scheduling of the EHs, without exposing their private information. For future work, we plan to include the operational constraints imposed by the electricity and natural gas networks, which are generally complex to be disposed in the game setting. Meanwhile, uncertainties in the renewables and energy demand will also be considered,

which can improve the applicability of this bargaining-based cooperative model.

## REFERENCES

- [1] L. Martini, "Trends of smart grids development as fostered by European research coordination: The contribution by the EERA JP on smart grids and the ELECTRA IRP," *Proc. IEEE 5th Int. Conf. Power Eng., Energy Elect. Drives (POWERENG)*, Riga, Latvia, May 2015, pp. 23–30.
- [2] Q. Ai and R. Hao, "Key technologies and challenges for multi-energy complementarity and optimization of integrated energy system," *Autom. Electr. Power Syst.*, vol. 42, no. 4, pp. 2–10, Feb. 2018.
- [3] Renewable Energy Institute. *Changing the Way the World Makes and Users Energy*. Accessed: Feb. 28, 2018. [Online]. Available: <http://www.integratedenergysystem.com/>
- [4] M. Geidl, G. Koeppl, P. Favre-Perrod, B. Klockl, G. Andersson, and K. Frohlich, "Energy hubs for the future," *IEEE Power Energy Mag.*, vol. 5, no. 1, pp. 24–30, Jan./Feb. 2007.
- [5] T. Krause, G. Andersson, K. Frohlich, and A. Vaccaro, "Multiple-energy carriers: Modeling of production, delivery, and consumption," *Proc. IEEE*, vol. 99, no. 1, pp. 15–27, Jan. 2011.
- [6] G. Darivianakis, A. Georghiou, R. S. Smith, and J. Lygeros, "A stochastic optimization approach to cooperative building energy management via an energy hub," in *Proc. 54th IEEE Conf. Decision Control (CDC)*, Osaka, Japan, Dec. 2015, pp. 7814–7819.
- [7] R. Hao, Q. Ai, Y. Zhu, H. Wu, and Z. Liang, "Hierarchical optimal dispatch based on energy hub for regional integrated energy system," *Elect. Power Autom. Equip.*, vol. 37, no. 6, pp. 171–178.
- [8] J. Wei, J. Wang, H. Gao, and X. Gao, "Optimal operation of micro integrated energy systems considering electrical and heat load classification and scheduling," in *Proc. IEEE Conf. Energy Internet Energy Syst. Integr. (EI2)*, Beijing, China, Nov. 2017, pp. 1–6.
- [9] A. Najafi, H. Falaghi, J. Contreras, and M. Ramezani, "A stochastic bilevel model for the energy hub manager problem," *IEEE Trans. Smart Grid*, vol. 8, no. 5, pp. 2394–2404, Sep. 2017.
- [10] T. Ma, J. Wu, and L. Hao, "Energy flow modeling and optimal operation analysis of the micro energy grid based on energy hub," *Power Syst. Technol.*, vol. 133, pp. 292–306, Feb. 2018.
- [11] A. Sheikhi, S. Bahrani, and A. M. Ranjbar, "An autonomous demand response program for electricity and natural gas networks in smart energy hubs," *Energy*, vol. 89, pp. 490–499, Sep. 2015.
- [12] S. Bahrani and A. Sheikhi, "From demand response in smart grid toward integrated demand response in smart energy hub," *IEEE Trans. Smart Grid*, vol. 7, no. 2, pp. 650–658, Mar. 2016.
- [13] A. Sheikhi, M. Rayati, S. Bahrani, and A. M. Ranjbar, "Integrated demand side management game in smart energy hubs," *IEEE Trans. Smart Grid*, vol. 6, no. 2, pp. 675–683, Mar. 2015.
- [14] F. Kamyab and S. Bahrani, "Efficient operation of energy hubs in time-of-use and dynamic pricing electricity market," *Energy*, vol. 106, no. 1, pp. 343–355, Apr. 2016.
- [15] S. Bahrani, M. Toulabi, S. Ranjbar, M. Moeini-Aghtaie, and A.-M. Ranjbar, "A decentralized energy management framework for energy hubs in dynamic pricing markets," *IEEE Trans. Smart Grid*, to be published, doi: [10.1109/TSG.2017.2723023](https://doi.org/10.1109/TSG.2017.2723023).
- [16] F. Wu, X. Liu, Y. Sun, N. Chen, T. Yuan, and B. Gao, "Game optimization strategy for multiple parks based on combined cooling heating and power," *Automat. Electr. Power Syst.*, to be published, doi: [10.7500/AEPS20170914005](https://doi.org/10.7500/AEPS20170914005).
- [17] M. Maschler, E. Solan, and S. Zamir, *Game Theory*. New York, NY, USA: Cambridge Univ. Press, 2013.
- [18] M. Ji and P. Zhang, "Transactive control and coordination of multiple integrated energy systems," in *Proc. IEEE Conf. Energy Internet Energy Syst. Integr. (EI2)*, Beijing, China, Nov. 2017, pp. 1–6.
- [19] T. Lu, Z. Wang, Q. Ai, and W.-J. Lee, "Interactive model for energy management of clustered microgrids," *IEEE Trans. Ind. Appl.*, vol. 53, no. 3, pp. 1739–1750, May/Jun. 2017.
- [20] J. Ni and Q. Ai, "Economic power transaction using coalitional game strategy in micro-grids," *IET Generat., Transmiss., Distrib.*, vol. 10, no. 1, pp. 10–18, 2016.
- [21] X. Yu and Y. Xue, "Smart Grids: A cyber-physical systems perspective," *Proc. IEEE*, vol. 104, no. 5, pp. 1058–1070, May 2016.
- [22] N. Liu et al., "Online energy sharing for nanogrid clusters: A Iyapunov optimization approach," *IEEE Trans. Smart Grid*, to be published, doi: [10.1109/TSG.2017.2665634](https://doi.org/10.1109/TSG.2017.2665634).
- [23] I. Zengin et al., "Cooperation in microgrids through power exchange: An optimal sizing and operation approach," *Appl. Energy*, vol. 203, pp. 972–981, Oct. 2017.
- [24] D. Zhang et al., "Fair electricity transfer price and unit capacity selection for microgrids," *Energy Econ.*, vol. 36, no. 3, pp. 581–593, Mar. 2013.
- [25] A. Muthoo, *Bargaining Theory With Applications*. Cambridge, U.K.: Cambridge Univ. Press, 2008.
- [26] S. Mhanna, G. Verbič, and A. C. Chapman, "A faithful distributed mechanism for demand response aggregation," *IEEE Trans. Smart Grid*, vol. 7, no. 3, pp. 1743–1753, May 2016.
- [27] A. Ehsanfar and B. Heydari, "An incentive-compatible scheme for electricity cooperatives: An axiomatic approach," *IEEE Trans. Smart Grid*, vol. 9, no. 2, pp. 1416–1424, Mar. 2018.
- [28] S. Boyd, N. Parikh, E. Chu, B. Peleato, and J. Eckstein, "Distributed optimization and statistical learning via the alternating direction method of multipliers," *Found. Trends Mach. Learn.*, vol. 3, no. 1, pp. 1–122, Jan. 2011.
- [29] Z. Wang, B. Chen, J. Wang, and C. Chen, "Networked microgrids for self-healing power systems," *IEEE Trans. Smart Grid*, vol. 7, no. 1, pp. 310–319, Jan. 2016.
- [30] Independent Electricity System Operator (IESO). *Power Data*. Accessed: Mar. 5, 2018. [Online]. Available: <http://www.ieso.ca>



**SONGLI FAN** (S'15) received the B.S. degree in electrical engineering and automation from Sichuan University, Chengdu, China, in 2013. She is currently pursuing the Ph.D. degree in electrical engineering with Shanghai Jiao Tong University, Shanghai, China. In 2016 and 2017, she was a Visiting Student with the Energy Systems Division, Argonne National Laboratory, Argonne, IL, USA, for six months. Her research interests include energy management on microgrids, virtual power plant, and regional integrated energy system.



**ZHENGSHUO LI** (S'12–M'16) received the B.S. and Ph.D. degrees from the Department of Electrical Engineering, Tsinghua University, Beijing, China, in 2011 and 2016, respectively. His research interests include economic dispatch and security analysis of smart transmission and distribution systems, distributed storage utilization, and demand response in smart grids.

Dr. Li was a recipient of the Excellent Graduates of Tsinghua University and of Excellent Doctoral Dissertation Award of Tsinghua University in 2016, the Best Paper Award of China National Doctoral Academic Annual Meeting and IEEE PES General Meeting, and the Best Reviewer Awards for IEEE Transactions on Smart Grid and for Proceedings of CSEE.

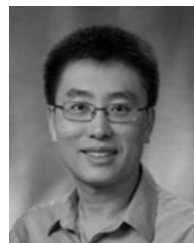

**JIANHUI WANG** (M'07–SM'12) received the Ph.D. degree in electrical engineering from the Illinois Institute of Technology, Chicago, IL, USA, in 2007.

He is currently an Associate Professor with the Department of Electrical Engineering, Southern Methodist University, Dallas, TX, USA. He is also the Secretary of the IEEE Power & Energy Society, Power System Operations, Planning & Economics Committee. He has held visiting positions in Europe, Australia, and Hong Kong, including a VELUX Visiting Professorship at the Technical University of Denmark. He was a recipient of the IEEE PES Power System Operation Committee Prize Paper Award in 2015. He is the Editor-in-Chief of the IEEE TRANSACTIONS ON SMART GRID and an IEEE PES Distinguished Lecturer.



**LONGJIAN PIAO** received the M.S. degree in electrical engineering from Shanghai Jiao Tong University, China, and from the Technical University of Berlin, Germany. He is currently pursuing the Ph.D. degree with the Delft University of Technology, The Netherlands. His research interests include direct current distribution systems and electricity market design for community grids.



**QIAN AI** (M'03–SM'16) received the B.S. degree from Shanghai Jiao Tong University, Shanghai, China, in 1991, the M.S. degree from Wuhan University, Wuhan, China, in 1994, and the Ph.D. degree from Tsinghua University, Beijing, China, in 1997, all in electrical engineering. He was with Nanyang Technological University, Singapore, for one year; the University of Bath, U.K., for two years. He is currently a Professor with the Department of Electrical Engineering, Shanghai Jiao Tong University, Shanghai, China. His research interests include load modeling, smart grid, microgrids, virtual power plant, regional integrated energy system, big data, and artificial intelligence.

...