

Received February 24, 2018, accepted April 16, 2018, date of publication April 25, 2018, date of current version June 5, 2018.

Digital Object Identifier 10.1109/ACCESS.2018.2830187

Analyzing Integrated Renewable Energy and Smart-Grid Systems to Improve Voltage Quality and Harmonic Distortion Losses at Electric-Vehicle Charging Stations

ASIF KHAN¹, SAIM MEMON, AND TARIQ PERVEZ SATTAR

Division of Electrical and Electronic Engineering, School of Engineering, London South Bank University, London SE1 0AA, U.K.

Corresponding author: Saim Memon (s.memon@lsbu.ac.uk)

This work was supported by London South Bank University.

ABSTRACT Increasing the use of electric vehicles (EVs) is regarded as a step in the right direction to reduce air pollution and carbon emissions. However, a dramatic increase of EV and charging stations has raised voltage quality and harmonic distortion issues that affect the performance of integrated renewable power sources (wind and solar) and smart-grid electrical transmission networks. This paper models an integrated electric vehicle charging and battery storage system operating in the presence of unpredictable wind and solar power sources. The aim is to enable the design of an electrical control system that develops the correct duty cycle to stabilize and regulate the voltage at the dc/dc power conversion station. Simulations are performed to evaluate energy management by the proposed control system. The proposed system effectively manages the electric power on the grid by drawing power from the batteries at peak times and then charging them in off-peak times, reducing the load on the converter and enabling the reduction of charging time for electric vehicles. A constant voltage is achieved on the grid irrespective of fluctuations in renewable energy generation and in the load.

INDEX TERMS Smart grid, electrical systems, voltage quality, electric vehicle, ac/dc conversion.

NOMENCLATURE

T_S	Switching frequency
R_p	Resistance on the micro grid (Ω)
I_{scn}	Solar current generation
V_3	Storage terminal voltage
I_{p3}	Storage current (A)
ΔT	Temperature difference [$^\circ$]
V_p	Micro grid voltage (V)
I_p	Micro grid current (A)
P_p	Power on micro grid (W)
P_1	Wind/solar terminal power (W)
V_c	AC/DC converter capacitor voltage (V)
I_1	AC/DC converter inductor current (I)

ABBREVIATIONS

kWh	kilowatt hour
VDC	Direct voltage current
EV	Electric-vehicle charging station
D	Duty cycle
IGBT	Insulated gate bipolar transistor

I. INTRODUCTION

Integration of large scale wind and solar farms into the UK transmission system has raised power quality, system stability and network synchronization problems [1]. Between 2015 to 2016, wind and solar farms increased by 51.2% with total capacity of 8.1 TWh [2]–[4]. In 2016, these renewable energy plants were connected to the UK national transmission system where they created several challenges of voltage quality and harmonic distortions due to variable wind flow/sunlight and variations in the electric load [5]. This paper investigates an isolated micro grid to solve the problems of power flow due to the creation of transients, inrush currents and disturbances in the grid, which can damage grid mechanisms and power generation units. The power flow on this type of micro grid can be via AC (alternating current) or DC (direct current). For DC type loads such as electric and hybrid vehicle charging stations, it is advantageous to develop a DC grid to reduce the charging time by reducing the number of power electronic converters [6]. There is no reactive power flow and no synchronization problems on the DC micro

grid and hence no phase correction is required in the power flow [7], [8]. DC storage systems can be connected to the micro grid as a better approach to maintain the power flow during disturbances in the wind and solar energy generation resources. Also, energy generation resources can be connected efficiently to the micro grid through power electronics converters. DC-DC converters are required for the solar farm and AC-DC converters are required for the wind farm. Electrical power control techniques can be implemented to maintain constant voltage on the grid. DC loads such as car batteries can be connected to the micro grid at car charging stations.

On the micro grid transmission network it is very important to keep voltages close to nominal values else it can lead the system to instability [9]–[11]. Instability due to the addition of power from battery banks, wind/solar energy and fuel generators can create massive damage to the network, equipment and eventually the economy [12]. Stability measurements can examine whether the system is performing in the correct state or heading towards instability [13] and should be considered at every point of the grid in order to take the appropriate action.

This paper focuses on methods to improve the voltage quality on the micro grid by examining voltage spikes and transmission of transients to reduce the effect of external parameters that create instability such as wind flow/sunlight and internal elements such as capacitance, inductance, and frequency control of IGBT switches. A voltage and power conversion closed-loop control system is implemented part of the smart grid and investigated to assess whether the grid is capable of handling large scale power flow. The control system prevents voltage reduction by applying a controlled duty cycle to the power conversion system and applying low pass filter techniques to remove transients. Power flow is maintained and regulated on the grid by drawing power from the batteries during energy shortages and batteries charged up at off peak times. The system is investigated by performing simulations using MATLAB/Simulink to study environmental effects on electric power generation and to discover the effects of over loading, under loading in the micro grid and simulation results are compared with a mathematical analysis.

II. PROPOSED SYSTEM

Construction of wind and solar farms are increasing every day. But in the meantime the transmission networks are getting overloaded and their efficiency is being reduced. For carrying out renewable energy transmission on a transmission grid, it is essential to study environmental conditions and load variations. Because it is a fact that load and environmental conditions are changing all the time. Therefore, it is very complicated to keep the constant stability for renewable energy transmission. The main reasons of instability issues due to renewable energy transmission are environmental conditions, synchronization and overloading. The efficiency of the network is also reduced as a result of overloading and related types of variations [14]. There is the need for a separate

type of network which should be able to transmit the power appropriately by accommodating constraints associated with these renewable resources. The power network should be able to deal with instability problems (due to changing climate conditions and load changes within the network) by maintaining stability at every point in the network. Instability can create massive damage to the network, equipment’s and eventually the economy.

Smart micro grid design is still unattainable for renewable energy transmission. Therefore, it is necessary to carry out research on the smart micro grid to solve the problems of power flow. The micro grid is beneficial to the power industry because generated energy is being transmitted in this grid; instead of the distribution grid. The author is contributing and proposing a new model for transmitting renewable energy. The research is contributed to improve renewable energy efficiency and reducing the power flow issues at the National grid. It connected electric cars directly to the micro grid where electric cars are capable of receiving and sending power. The research is also useful for transmitting renewable energy in rural areas and on the Islands. Power flow control and stability have to be achieved automatically by means of closed loop control principles. The implemented structure of the system is shown in Fig.1.

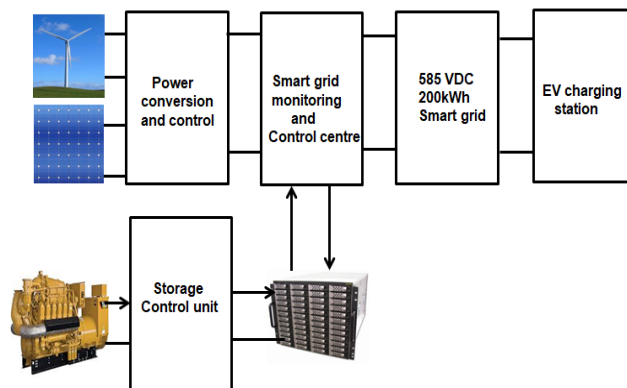

FIGURE 1. Implemented schematic structure of the system.

The proposed model structure of the smart grid is shown in Fig.2 is simulated in a MATLAB/Simulink environment. It comprises of a control and monitoring center, a smart protection system, a stability control system, a measurement system to regulate the power flow on the micro grid. The smart micro grid transmission system is the part between the energy sources (wind, solar, fuel generator, energy storage system) and the load (EV charging station). The smart grid uses the control, protection, computer technology and communications to transmit the energy with high reliability. The smart grid incorporates the renewable energy generations and storage options and enabling new services such as vehicle-grid energy flow. It is categorized to increase reliability of power applications such as voltage regulations, power efficiency etc. The energy storage system is one of major component of the smart grid. Transmitting renewable energy

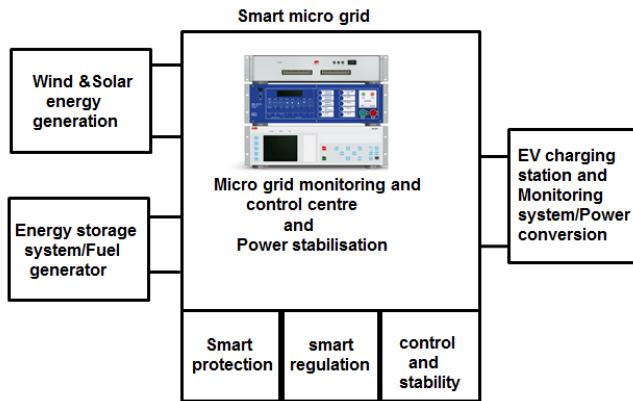

FIGURE 2. A schematic diagram of the integrated smart model consisting of wind unit, Photovoltaic (PV) system, storage system, Electric Vehicle (EV) charging station, and the micro grid related components.

effectively into grid requires energy storage system that stores large amount of energy. Lithium ion and sodium sulphate type batteries are most suitable for these types of applications. It supports the energy demands during the peak times and charge up in the off-peak times.

A DC micro grid consists of only resistances in series along the length of a line and capacitance and inductance are not considered due to DC power transmission. Power in a DC grid fed from wind and solar energy generation units is always fluctuating. If the load is inductive or capacitive than transients and spikes arise in the grid and a regulatory system is required to create balance. Achieving the desired voltage depends on the duration of current flow where the inductor has better performance at lower frequencies while the capacitor has better performance at higher frequencies.

A. RENEWABLE ENERGY

The power is injected on the network from several power supplying resources such as wind turbines, photovoltaic panels. In the wind energy system, a doubly fed induction generator is used to generate electrical energy because it provides constant frequency and amplitude of the output voltage. It does not depend on the wind speed because its stator winding is directly connected to the grid. On the other hand, rotor windings transfer approximately 30% of the total power by using converters and operate at lower wind speed. Energy storage system is included that supplies electric power back to the grid when there is not enough power generated from wind/solar sources. This storage system is connected to a fuel generator that charges up batteries only in emergency when there is a deficiency of nominal power transmission to the grid. Tab.1 shows the energy generation units that contain the wind/solar system to supply energy to the Electric Vehicle (EV) charging station.

B. ELECTRIC VEHICLES CHARGING POINTS

UK power Network has installed the 60 dual outlet charging point across London in July 2013 in 12 London underground

TABLE 1. Energy resources and storage system/fuel generation system.

Wind energy	100kWh
Solar energy	100kWh
Total solar units required	304
Single unit energy generation capacity	330Wh
Storage system	200kWh
Fuel generator	200kWh
EV max load	103.50kWh

car parks. The rated capacity of these installed charging points is 3.5kWh to 120kWh. The voltage used to charge up the electric-vehicles is 230VAC to 400VAC. These charging points are connected to the distribution grid.

Charging up the electric-vehicles directly from the grid are not suitable creates power flow issues such as voltage sags, harmonics and voltage spikes. Electric vehicles are powered by batteries but currently it takes a long time to charge up. The vehicle engine needs to be running to store power in the batteries, support vehicles when climbing hills and to maintain a given speed [15], [16]. To meet these requirements, demands on the new technology are investigated. DC power flow is found to be most reliable and efficient for this task because it charges up batteries in very short time [17]. DC power charging up also improves the efficiency of the power flow in electric cars by supplying the required power using converters to AC electric machines used in electric or hybrid cars [18].

The proposed system drives the charging points of UK power network by a voltage of 585VDC. The electric vehicle charging station consists of 4 charging points with maximum power consuming capacity of 103.50 kWh. The power consuming capacity of individual EV charging terminal is shown in Tab.2.

TABLE 2. The operating features for the electric-vehicle charging station.

Electric-vehicle charging point capacity	Voltage at the grid side (DC)
3.5kW	585V
7kW	585V
43kW	585V
50kW	585V
Fully operational	585V

Fig.3 shows a charging time comparison for the electric-vehicles batteries between the AC grid and DC grid. 8kWh battery takes 45 minutes to charge up from the AC grid while it is reduced to 10 minutes from the DC grid. It takes 160 minutes to charge up from the main grid. The purpose of designing such system is to reduce the power flow issues at the existing transmission system. The power network should be able to deal with instability problems (due to changing

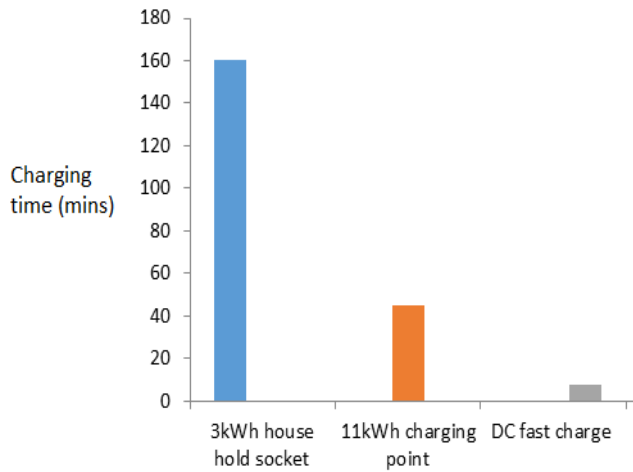

FIGURE 3. Charging time reduction between the AC grid (3kWh and 11kWh) and the DC grid.

climate conditions and load changes within the network) by maintaining stability at every point in the network.

C. ENERGY CONVERSION

The power conversion system with AC/DC and DC/DC components used to stabilise the voltage and to control the frequency of insulated gate bipolar transistor (IGBT) switches is shown in Fig.4. It senses the voltage and current and applies the correct duty cycle to IGBT switches in order to regulate the voltage flow at the micro grid. Buck converters are implemented at the EV charging station to reduce the voltage. Boost converters are used to step up the voltage from the solar panels while buck-boost converters are used to regulate the voltage at the micro grid monitoring and control centre.

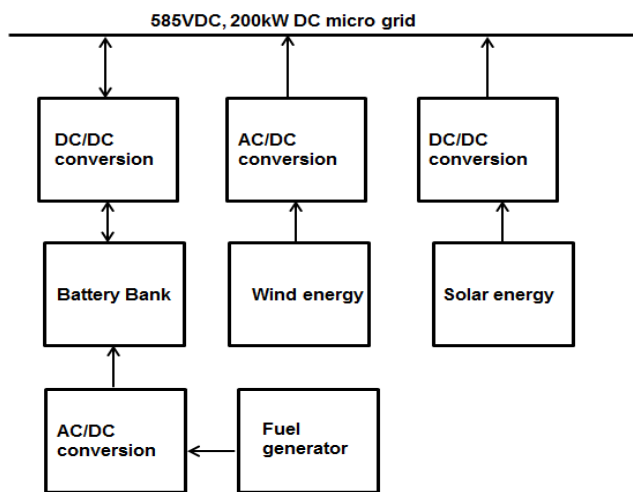

FIGURE 4. Block diagram of power conversion system connected to micro grid.

In the AC/DC power conversion system, the structure of the control system used to regulate the voltage flow on the micro grid is shown in Fig.5. A MATLAB script is used to

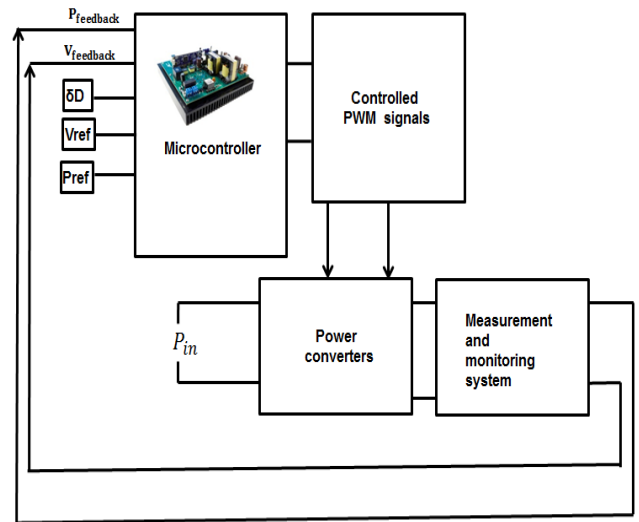

FIGURE 5. The block diagram of applied control system to achieve voltage regulation.

implement the feedback controller to calculate the correct duty cycle. The controller is equivalent to a microcontroller that would be used in practice to control the frequency of the converter IGBT switches by applying variable pulses to achieve the desired voltage. The controller receives two sensor signals from the converter output and compares them with a reference signals to generate error signals and compute the correct output to reduce instability. The input δD is used to create a variability of 0.001 in the duty cycle. The switching frequencies of high power IGBT switches are very low and they produce voltage spikes in the voltage. To solve this problem, a PWM control strategy is applied to reduce the harmonics and smooth the output waveforms. The output voltage of the power converters is decided by the PWM switching by applying the eight ON and OFF states of the three phase PWM pulses. The duty cycle applied to the power converter switches is between 0 and 1. The duty cycle controls the speed of the IGBT switches at the converter station. It is observed that by increasing the PWM pulse frequency, voltage spikes are reduced. Transients and voltage spike waveforms are analyzed and reduced by using power electronic filters.

The structure of the protection system used to protect the micro grid is shown in Fig.6. The protection system consists of all the necessary tools such as controller, sensors, relays and breaker or switches. Voltage and current flow signals on the grid are transmitted to a controller to perform required actions. The output of the controller is connected to a DC circuit breaker. The Controller isolates the grid and power components when voltage or current exceeds a high threshold level. The reference voltage represents the maximum voltage which a circuit breaker compares to the grid voltage.

III. EV PERFORMANCE AND ENERGY MANAGEMENT

Power flow in the system is intermittent due to energy generation from the renewable energy solar/wind sources. The algorithm to manage power on the micro grid is shown

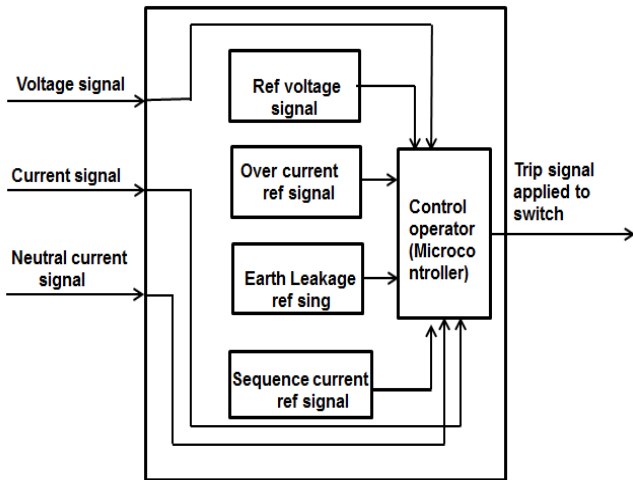

FIGURE 6. Block diagram shows an interconnected power conversion system implemented at the micro grid.

in Fig.7. The electric-vehicle charging station is considered to be fully operational. Four charging points with the total capacity of 103.50 kWh are connected to the micro grid terminal which is extracting energy from the wind/solar system. These representative charging points are commonly found in most EV charging stations in London. The proposed system has the capability to run the electric-vehicle charging station from wind/solar and storage system/fuel generators.

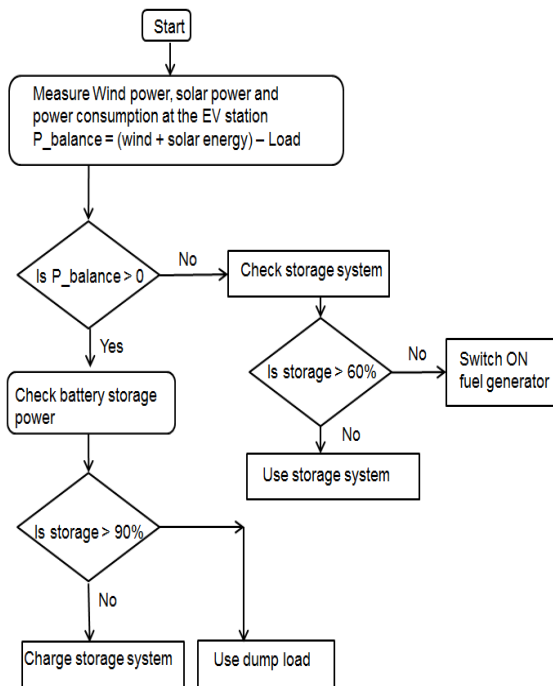

FIGURE 7. The system energy management algorithm.

Investigations are performed by comparing the energy generated by the wind turbines and solar units with the EV station and the losses in the converters/grid. The controller located

at the micro grid and control centre measures the generated energy from the wind and solar system to compare with the load side. If the combined energy from the wind and solar system is more than the total energy consumption at the load side and the losses in the system than it checks the charging of the storage system. If the storage system is less than 80% of the full capacity then it charges the storage units. The storage system is not charged if the wind/solar generated energy is less than or equal with the load on the micro grid. If the load on the micro grid is more than the total generated energy by the wind/solar system, than the storage system will be used to supply power to the micro grid. The nominal power generation capacity of the wind/solar energy resources are shown in Fig.8.

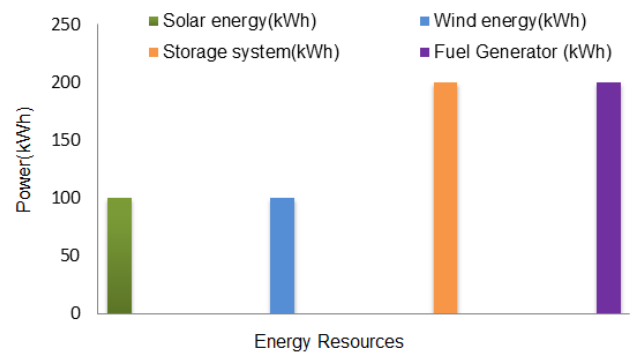

FIGURE 8. The energy resources connected to the micro grid.

A 24 hour analysis is carried out to maintain the power flow on the micro grid. The energy generation pattern for a 24 hour period is shown in Fig.9 where the effects of temperature, irradiation and wind flow are illustrated. From 12am to 9pm, the energy generated is close to the nominal values. The fewer losses are due to temperature effects on the solar system and wind flow. From 9pm-5am, there is solar energy generation due to irradiation effects on the solar system, but the wind units is still operational and generating the electrical energy.

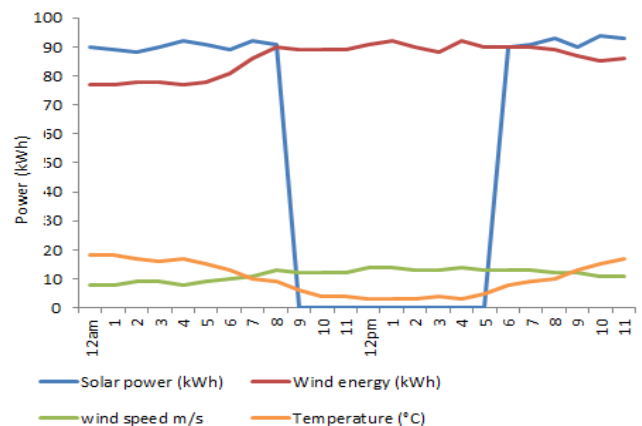

FIGURE 9. Energy generated by the solar/wind farms for a 24 hours period.

At this point (9pm-5am), the combined solar and wind energy is not enough to run the EV station during the peak times.

The battery storage system will be required to be operational from 9pm to 5am to balance the power on the micro grid because no energy is being generated by the solar system during this period. The storage system should have the capability to meet the energy demand at the electric-vehicle charging station during this scenario. Fig.10 demonstrates the power supplied by the storage system; initially the storage system is 200kWh (fully charged) and then the storage energy reduces at 10pm when it is supplying power to electric-vehicle charging station. The fuel generator is switched ON from 2pm to 6pm to charge up the storage system after its storage capacity falls to 60%. The equation used to calculate the terminal voltage at the storage system is given by Eq.1.

$$V_i = V_o + R_i \cdot I_3 - K \frac{Q}{Q} \int i_3 dt + A \cdot \exp \left(\int_0^t i_i dt \right) \quad (1)$$

Where V_i is the i -th terminal voltage and current of the storage system during functioning, V_o is the terminal voltage during open circuits, R_i is the storage system internal resistance, I_3 is the storage current, Q is the rated capacity of the storage system, and K is the polarisation resistance, and A is the exponential voltage. The storage system is connected to the DC micro grid by DC/DC bi-directional converters and an electrical control system. The controller is used to detect the voltage/power flow on the micro grid and then supply power from the storage system during power shortages.

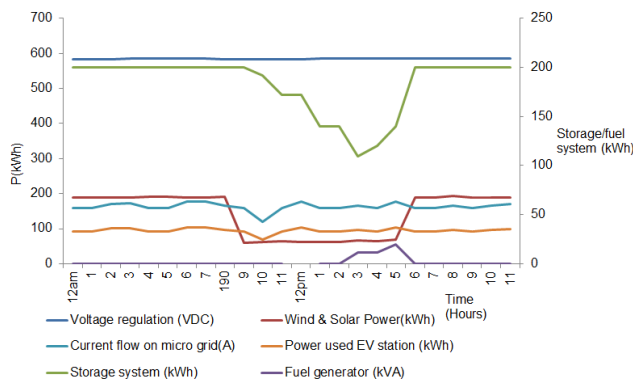

FIGURE 10. Energy management when EV is charging during the 24 hours period.

During the operational hours from 5am-9pm; the transmitted energy is received from the renewable energy resources (wind/solar) and the storage system is in standby mode at this point. The solar unit is fully operational and generating the maximum energy during this period and meeting the energy demands at the EV charging station. The comparison of the combined energy from the wind/solar with the EV charging station is shown in Fig.11 and at this stage several charging points are considered operational.

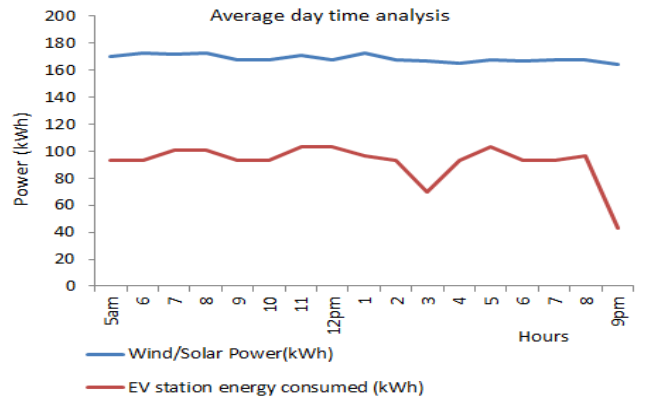

FIGURE 11. Graph showing that the wind/solar energy generation is capable of running the EV station independently from 5am-9pm.

A. VOLTAGE REGULATION AND CONTROL

The voltage on the DC micro grid is maintained by implementing the correct duty cycle at the AC/DC IGBT converter switches and by supplying the required power to the loads. The closed loop feedback system, shown in Fig.12, is used to generate the precise duty cycle; controller receives the signal from the output of the converter by closed feedback links and generates the variable duty cycle by comparing the output feedback voltage with the reference voltage. It updates the duty cycle by detecting the voltage difference between the output voltage and the reference voltage. The regulated voltage is then transmitted on the smart grid to the electric-vehicle charging station.

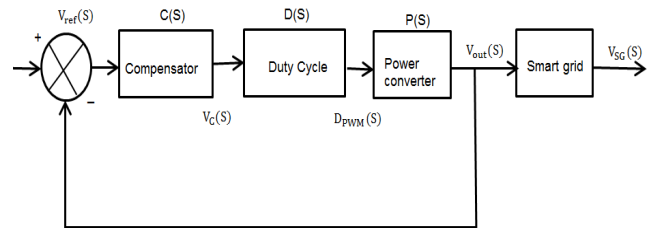

FIGURE 12. Schematic diagram of the closed loop feedback control system for the converter sections for voltage regulation.

By using the transfer functions; an expression are derived to generate the duty cycle and to perform converters analysis. For the state space representation inductor current and capacitor voltage are considered. The inputs are duty cycle, the input current i_{DC} and the converter output voltage. D is the duty cycle applied to the converters, v_c represents the capacitor voltage and i_l is the inductor current and controller is represented by $R_{contoller}$. $\frac{di_l}{dt}$ is the change in current and $\frac{dv_{c_i}}{dt}$ is the change in voltage in the converters.

$$D(S) = \frac{D_{PWC}(S)}{V_C(S)} \quad (2)$$

$$PS(S) = \frac{V_C(S)}{D_{PWC}(S)} \quad (3)$$

The expression below illustrates the transfer function for the duty cycle generation

$$D(S) = \frac{\tilde{D}_{PWC}(S)}{\tilde{V}_C(S)} \quad (4)$$

The following equations describe the voltage that is driving the PWM controller.

$$v_c = V_c + \tilde{v}_c \quad (5)$$

$$\text{If } \tilde{v}_c = a \cdot \sin(\omega t - \phi) \quad (6)$$

The duty cycle generation from the controller is given by

$$D_{pwm} = \frac{V_C}{V_{max}} + \frac{a}{V_{max}} \sin(\omega t - \phi) \quad (7)$$

where

$$D_{pwm} = dp_{PWM} + \tilde{d}_{pwm} \quad (8)$$

By combining the two equations the transfer function for the PWM controller can be obtained.

$$D = \frac{D_{pwm}}{\tilde{v}_c} \quad (9)$$

$$D = \frac{1}{\frac{V_{max}}{1}} \quad (10)$$

$$D = \frac{1}{V_{max}} \quad (11)$$

The two differential equations are:

$$\frac{di_l}{dt} = \frac{vc_i}{L} - \frac{vb(1-D)}{L} \quad (12)$$

$$\frac{dvc_i}{dt} = \frac{i_{DC}}{C_i} - \frac{vc_i}{C_i * R_{cnt}} - \frac{i_l}{c_i} \quad (13)$$

In matrix form:

$$\begin{bmatrix} \frac{di_l}{dt} \\ \frac{dvc_i}{dt} \end{bmatrix} = \begin{bmatrix} 0 & \frac{1}{L} \\ -\frac{1}{C_i} & -\frac{1}{C_i * R_{cnt}} \end{bmatrix} \begin{bmatrix} i_l \\ VC_i \end{bmatrix} + \begin{bmatrix} vb & 0 & \frac{-1+D}{L} \\ 0 & \frac{1}{C_i} & 0 \end{bmatrix} \begin{bmatrix} d \\ i_{dc} \\ vb \end{bmatrix} \quad (14)$$

$$\dot{x} = A_1 \cdot x + B_1 \cdot V_d \quad (15)$$

Therefore $x = \begin{bmatrix} i_l \\ VC_i \end{bmatrix}$, $A_1 = \begin{bmatrix} 0 & \frac{1}{L} \\ -\frac{1}{C_i} & -\frac{1}{C_i * R_{cnt}} \end{bmatrix}$,

$$B_1 = \begin{bmatrix} vb & 0 & \frac{-1+D}{L} \\ 0 & \frac{1}{C_i} & 0 \end{bmatrix}, V_d = \begin{bmatrix} d \\ i_{dc} \\ vb \end{bmatrix} \quad (16)$$

The equations, as detailed below, are used to measure the magnitude of ripples for the capacitor voltage and inductor

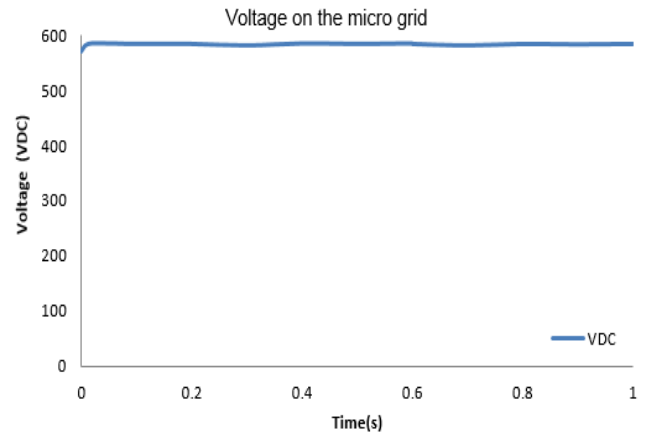

FIGURE 13. Voltage regulation on the micro grid.

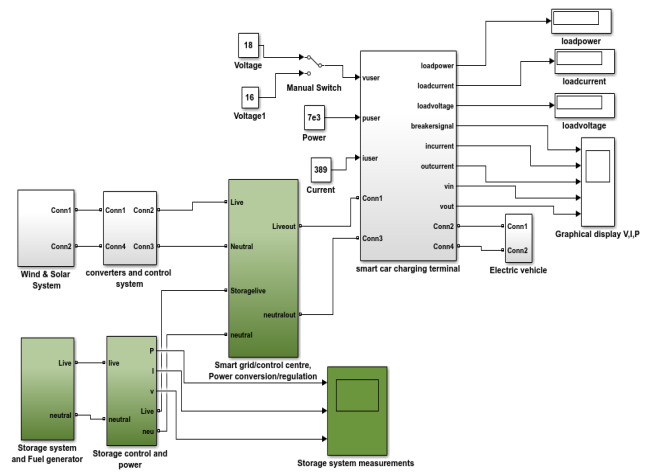

FIGURE 14. Simulation of the system used to investigate the smart grid that connects wind/solar to the EV charging station.

current where T_s is the switching frequency applied to converter switches and D is the duty cycle.

$$\Delta i_L = \frac{vc_i}{2L} DT_s \quad (17)$$

$$\Delta vc_i = \frac{DT_s}{2C_i} \left(I_{DC} - \frac{vc_i}{R_{cnt}} - i_l \right) \quad (18)$$

From the state space equations, the transfer function $G_d(s)$ between input voltage to the converters and the duty cycle is given by

$$G_d(s) = -\frac{R_{cnt}Lv_b}{LC_iR_{cnt}s^2 + Ls + R_{cnt}} \quad (19)$$

The observability matrix of the system is given in Eq.20 and it shows that system is observable.

$$Ob = \begin{bmatrix} 0 & 1 \\ -\frac{1}{C_i} & \frac{1}{c_i R_{cnt}} \end{bmatrix} \quad (20)$$

From the controllability matrix below, the system is always controllable if the determinant of this matrix is non-zero,

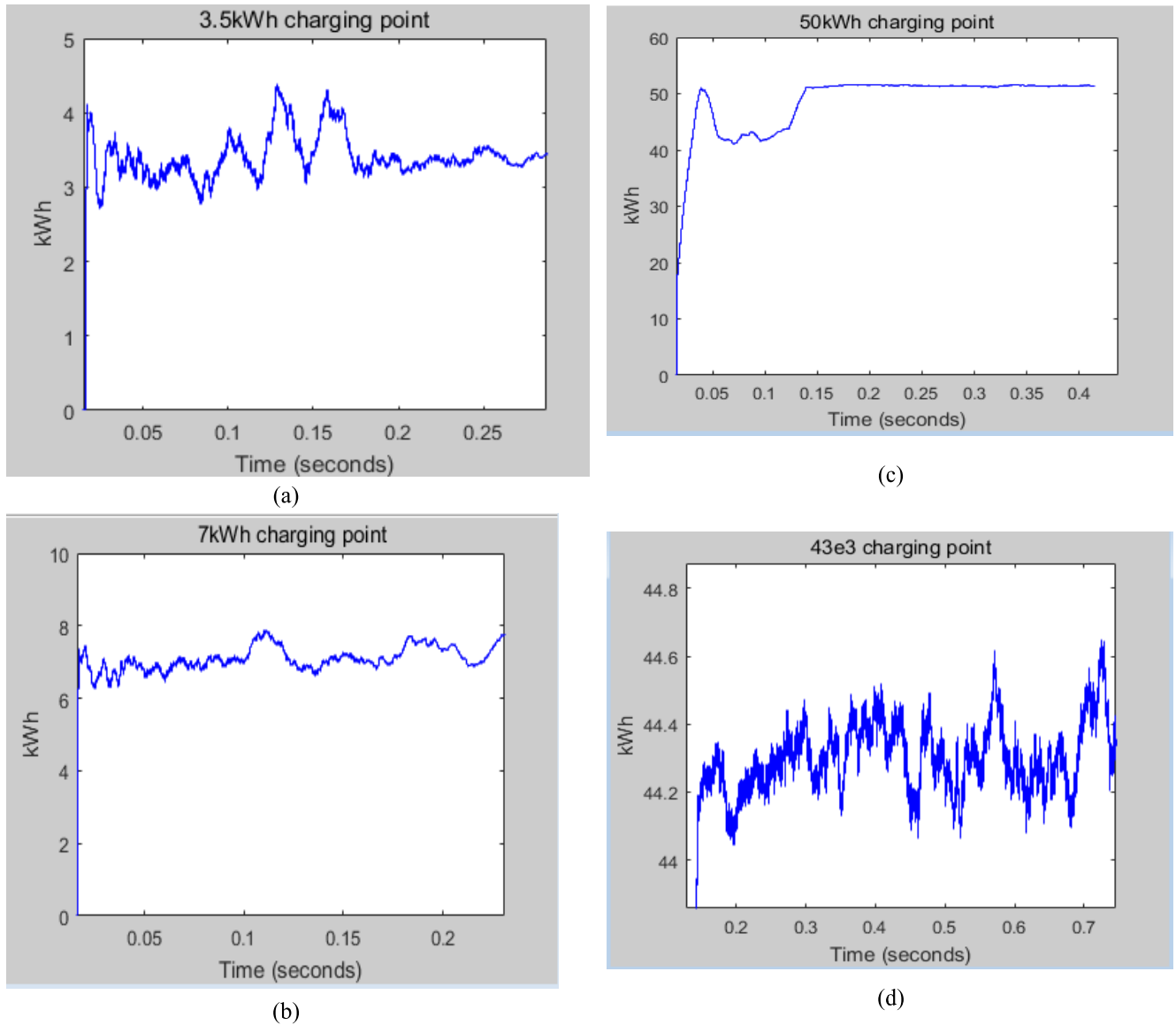

FIGURE 15. Simulation results of power drawn by four charging point.

similarly the observability.

$$C_o = \begin{bmatrix} V_b & 0 \\ 0 & -\frac{v_b}{c_i} \end{bmatrix} \quad (21)$$

To examine the stability of power flow/voltage on the micro grid, resistance, power, and voltage are considered at a terminal to create the mathematical model. A constant voltage (V) is assumed at every terminal because it is stabilized by the converter stations which are linked to the grid. The other converters are assumed to be constant power (P) regulators that connect the renewable energy sources, storage system, and fuel based generation system with the grid. Constant resistance (R) is assumed due to the linear and fixed size conductors used for power transmission. The power in the DC micro grid is divided into three subsets of {V, R, P}.

Multiple constant voltage terminals are represented by $v = N \times N$ with a linked resistance where N is the number of the terminals. Five power converter stations of the type shown in Fig.2 are connected to the grid at several points. The main terminal to maintain a constant voltage on the grid is the micro grid control and monitoring center, shown in Fig. 1, and is linked with the others terminals connected to the grid.

The list of power conversion stations connected to the Grid terminals are as follows,

- a) AC/DC power conversion station for the wind turbines
- b) DC/DC power conversion station for the solar units
- c) Central micro grid control and monitoring center for power regulation
- d) DC/DC bidirectional conversion systems for the storage system
- e) AC/DC conversion systems for the fuel generator

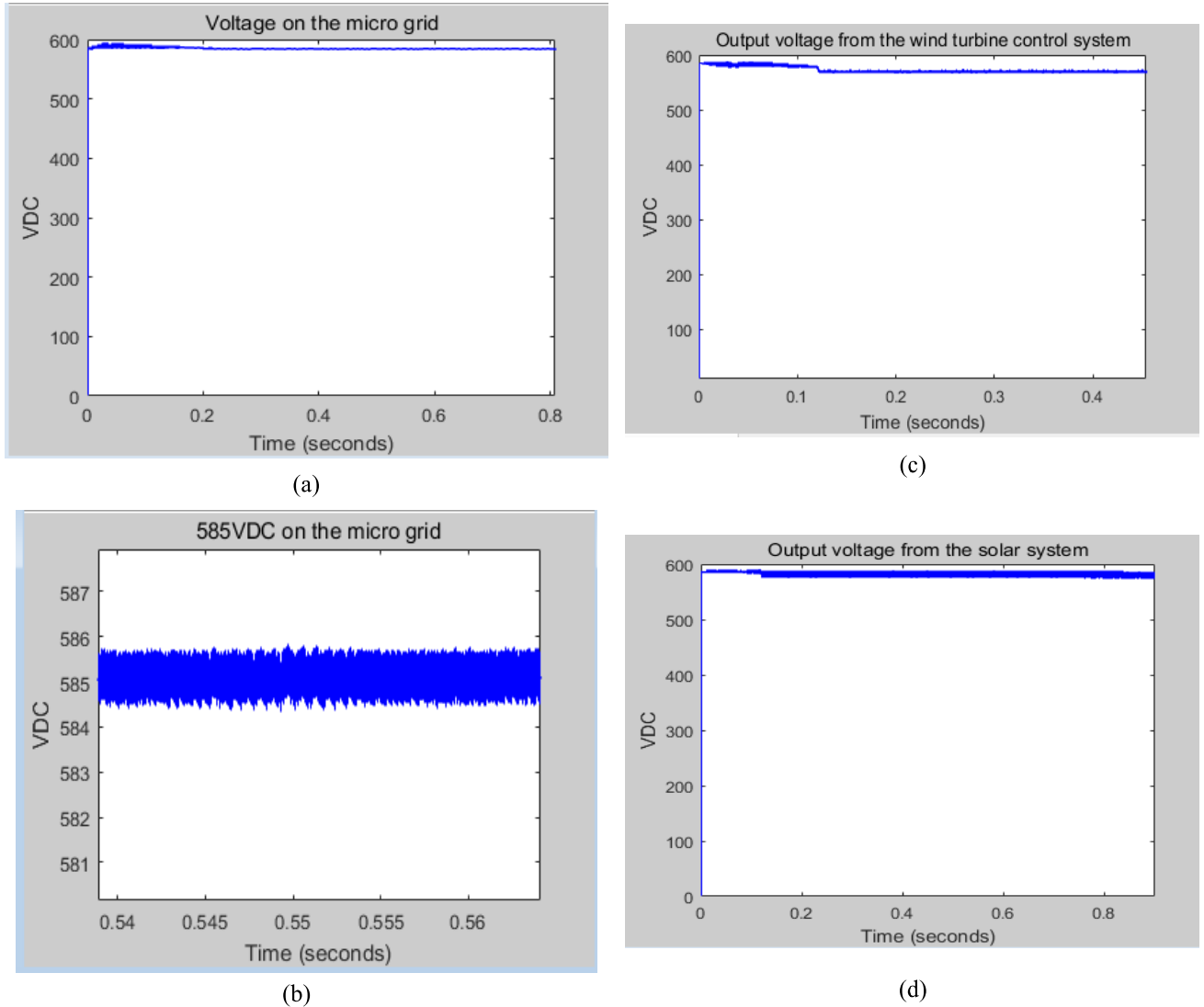

FIGURE 16. (a) Illustrates voltage regulation on the micro grid (b) Voltage output from the solar system (c) minor oscillations in the desired voltage on the micro grid (d) regulated DC voltage achieved at AC/DC power conversion station from the wind turbines.

Grid nodes are classified in terms of control being used to regulate the voltage and power flow from the terminals. The admittance matrix for the terminals voltage V and current I on the grid $G \in \mathbb{R}^{N \times N}$ is as follows in Eq.22 and I_R in Eq.23.

$$\begin{bmatrix} I_V \\ I_R \\ I_P \end{bmatrix} = \begin{bmatrix} G_{VV} & G_{VR} & G_{VP} \\ G_{RV} & G_{RR} & G_{RP} \\ G_{PV} & G_{PR} & G_{PP} \end{bmatrix} \cdot \begin{bmatrix} V_V \\ V_P \\ V_R \end{bmatrix} \quad (22)$$

$$I_R = -D_{RR} \cdot V_R \quad (23)$$

For a single step node such as the smart grid control and monitoring centre, this matrix can be singular as shown in Eq.24. Where the admittance matrix is D_{RR} is diagonal and comprises of constant power links.

$$V_R = -(D_{RR} + G_{RR})^{-1} (G_{RV} \cdot V_V + G_{RP} \cdot V_P) \quad (24)$$

$$I_P = J_P + B_{PP} \cdot V_P \quad (25)$$

The power flow is evaluated by using the constant medium voltage of 585VDC. Power terminals are linked by the

following equations where V_P is the voltage on the micro grid is and I_P is the current flow.

$$P_P = \text{diag}(V_P) \cdot I_P \quad (26)$$

The main terminal required to regulate the power flow on the grid is the storage system connection with the micro grid. This terminal detects the voltage drops and power requirement on the grid to activate the storage system for supplying electric energy. P_P is simplified to Eq.27.

$$P_P = \text{diag}(V_P) \cdot (J_P + B_{PP} \cdot V_P) \quad (27)$$

Where,

$$J_P = G_{PV} - G_{PR} \cdot (D_{RR} + G_{RR})^{-1} \cdot G_{RV} \cdot V_V \quad (28)$$

$$B_{PP} = G_{PP} - G_{PR} \cdot (D_{RR} + G_{RR})^{-1} \cdot G_{RP} \quad (29)$$

B_{PP} is the susceptance.

The level of voltage on the DC micro grid was set with Eq.30.

$$V_P = B_{PP}^{-1} \cdot (\text{diag}(V_P^{-1}) \cdot P_P - J_P) \quad (30)$$

$$\alpha = \frac{\|B_{PP}^{-1}\| \cdot \|P_{PP}\|}{V_{\min}^2} \quad (31)$$

Where α is the ratio between short circuit current and operational current flow at minimum voltage. The voltage on the DC grid is maintained by supplying the required power to the loads and by applying the correct duty cycle at the converter switches. Fig.13 shows the voltage stability obtained on the micro grid. This graph is generated from the mathematical equations above and is validated by the simulation results presented in section 4. The transients and oscillations are removed by using a 50kHz switching frequency that is applied to IGBT converter switches and by using low pass filters.

IV. SIMULATION RESULTS

Power flow on the micro grid is investigated by performing simulations of the system in MATLAB/SIMULINK is shown in Fig.14 and models of its power components.

The amount of power flow depends on the number of electric vehicles/type of batteries. The required energy is available on the micro grid constantly irrespective of variations in wind/solar energy as shown in Fig.15 (a-d). It shows the capability of the system to supply the required power to the EV charging station for the 24 hours period. The losses on the micro grid are recorded negligible due to short operation times and limited power flow. A spike in power flow is observed when charging up of converter components. Power flow on this grid is available constantly irrespective of variations in wind/solar energy.

It is verified that the proposed control algorithm is operating correctly; that it increases the efficiency of the system by reducing the losses and by extracting maximum power from th solar/wind energy sources. The controller senses the input voltage and current to generate the duty cycles to regulate voltage. The voltage flow recorded on the grid is 585VDC, as shown in Fig.16 (a-d). Oscillations are observed because of energy fluctuations in the inductance and capacitance in the converters/line and on the load side. It is observed that different inductors provide different load response. Higher inductance creates lower peak currents and reduces losses and improves the efficiency. Secondly, the switching frequency of the IGBT switches affects the current flow on the micro grid. Higher switching frequency creates lower ripples in current and vice versa. The amount of power flow depends on the numbers of cars and type of batteries.

To remove the transients and harmonics from the micro grid transmission system; low pass filters are implemented which regulate the voltage and maintain the current level by reducing the voltage spikes. A bidirectional converter with control is placed between the DC micro grid and the

battery bank which charges up and discharges the batteries by monitoring the power flow at the grid. Sensors are connected at every section of the micro grid to measure the power flow. The grid includes circuit breakers which are used to protect the grid during short circuits and any other types of faults. This grid enables plug in electric vehicles to be directly connected to the micro grid. The main parameters are calculated by using typical sizes and types of conductor. If the rate of change of current is double or inductance increases to double than the induced e.m.f also doubles in the line [19], [20].

The inductance and the output capacitance of the DC-DC power converters form a second order low pass filter. This filter is used to reduce the ripples in the energy supply generated by PWM pulses. Any changes to inductance or capacitance affect the voltage and output current from the converter system. The output capacitors of a low pass filter is an important part of the feedback converter system because it is the key component to reduce the transient's response in the power supply. The load current has the direct impacts on the input voltage deviations, because increase in transients at the output current creates transients in the input voltage. Higher input capacitance is required to minimise the transients in the voltage because lower input voltage will allow higher current to flow and increases transients. The output capacitors of the converter must be charged and discharged to allow the flow of energy and reduce the voltage. The transients are reduced by increasing the capacitor values and by increasing the switching frequency of the converters. When a transient occurs in the system, then the controller receives the changes in the output voltage and compensates it by changing the duty cycle as shown in Fig.17. The change in output current is limited by the inductance of the output filters even if the duty cycle rises to 100%.

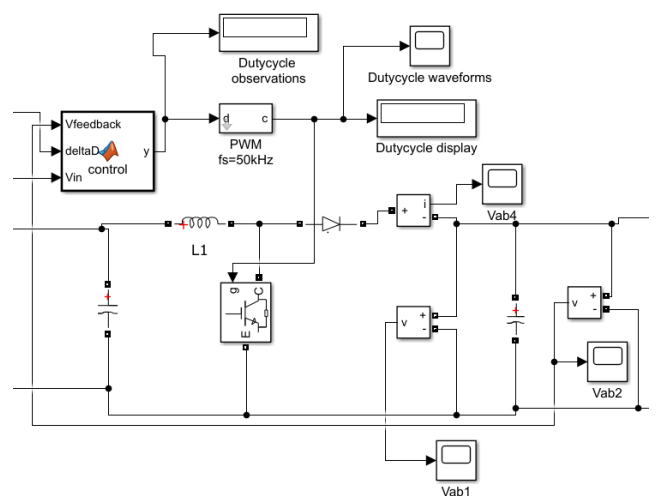

FIGURE 17. The applied control system to regulate the power flow.

The aim of implementing the control algorithm is to stabilize the power flow in fast changing environmental conditions such as irradiance and wind speeds. This is achieved by

applying the correct variable duty cycle as shown in Fig.18 to the energy converter switches.

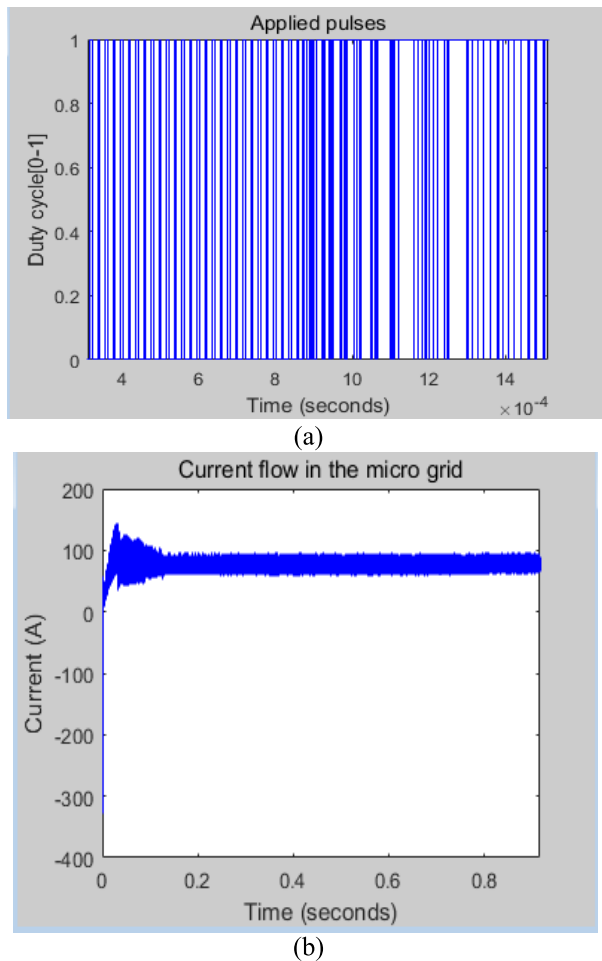

FIGURE 18. (a) Applied duty cycle to stabilise the fluctuating voltage from the wind and solar farms (b) Regulation of current flow in the micro grid.

V. CONCLUSION

A smart DC micro grid is proposed that connects fluctuating renewable energy sources such as wind and solar to electric vehicle charging stations on a grid that is separate from the national distribution grid. The aim is to avoid power flow issues such as transients, voltage reductions, harmonics and losses at the existing UK national transmission system. The smart grid includes energy storage systems to supply power to the grid during higher energy demands and when the renewable sources are not producing enough energy. The advantages of an independent DC micro grid are that it reduces charging time for electric and hybrid vehicles, has lower line losses due to shorter lengths and requires fewer power converters. Voltage regulation on the grid is achieved by measuring power flow at different points, implementing a smart communication system to provide feedback signals to a control system. The control system applies the correct duty cycle to converter switches at a higher switching frequency at the buck converter station. Power fluctuations are minimized

by applying filters following the mathematical modelling and simulation results. The proposed micro grid is analyzed mathematically and simulated with standard Simulink toolboxes over a twenty four hour period to assess its voltage regulation capability. The desired voltage level of 585 VDC is attained at the car charging station and findings indicate an improvement of the voltage regulation efficiency to 99% and reduction of electrical power losses in the micro grid to 1%.

ACKNOWLEDGEMENTS

The authors would like to thank the London South Bank Innovation Centre for Automation of NDT and the Research Enterprise & Innovation Centre at London South Bank University. For the research facilities support provided. This research did not receive any specific grant from funding agencies in the public, commercial, or not-for-profit sectors.

REFERENCES

- [1] M. Sheng, D. Zhai, X. Wang, Y. Li, Y. Shi, and J. Li, "Intelligent energy and traffic coordination for green cellular networks with hybrid energy supply," *IEEE Trans. Veh. Technol.*, vol. 66, no. 2, pp. 1631–1646, Feb. 2017.
- [2] C. Edwards, "The 100 per cent solution," *IET J. Eng. Technol.*, vol. 11, pp. 38–41, 2016.
- [3] G. Parkes and C. Spataru, "Integrating the views and perceptions of U.K. energy professionals in future energy scenarios to inform policymakers," *Energy Policy*, vol. 104, pp. 155–170, May 2017.
- [4] S. J. G. Cooper, G. P. Hammond, M. C. McManus, and D. Pudjianto, "Detailed simulation of electrical demands due to nationwide adoption of heat pumps, taking account of renewable generation and mitigation," *IET Renew. Power Generat.*, vol. 10, no. 3, pp. 380–387, 2016.
- [5] Y. V. P. Kumar and R. Bhimasingu, "Electrical machines based DC/AC energy conversion schemes for the improvement of power quality and resiliency in renewable energy microgrids," *Int. J. Elect. Power Energy Syst.*, vol. 90, pp. 10–26, Sep. 2017.
- [6] M. Dufour, A. Devie, and K. McKenzie, "Durability and reliability of electric vehicle batteries under electric utility grid operations: Bidirectional charging impact analysis," *J. Power Sources*, vol. 358, pp. 39–49, Aug. 2017.
- [7] Y. Shi, R. Li, Y. Xue, and H. Li, "High-frequency-link-based grid-tied PV system with small DC-link capacitor and low-frequency ripple-free maximum power point tracking," *IEEE Trans. Power Electron.*, vol. 31, no. 1, pp. 328–339, Jan. 2016.
- [8] K. S. H. Beagam, R. Jayashree, and M. A. Khan, "A new DC power flow model for Q flow analysis for use in reactive power market," *Int. J. Eng. Sci. Technol.*, vol. 20, no. 2, pp. 721–729, 2017.
- [9] H. Liu and J. Sun, "Voltage stability and control of offshore wind farms with AC collection and HVDC transmission," *IEEE J. Emerg. Sel. Topics Power Electron.*, vol. 2, no. 4, pp. 1181–1189, Dec. 2014.
- [10] A. Mohantya, M. Viswandyaa, S. Mohanty, P. K. Ray, and S. Patrad, "A new DC power flow model for Q flow analysis for use in reactive power market," *Int. J. Elect. Power Energy Syst.*, vol. 20, pp. 444–458, 2016.
- [11] S. Kazemlou and S. Mehraeen, "Decentralized discrete-time adaptive neural network control of interconnected DC distribution system," *IEEE Trans. Smart Grid*, vol. 5, no. 5, pp. 2496–2507, Sep. 2014.
- [12] M. Nijhuis, M. Gibescu, and J. F. G. Cobben, "Application of resilience enhancing smart grid technologies to obtain differentiated reliability," in *Proc. IEEE 16th Int. Conf. Environ. Elect. Eng. (EEEIC)*, Florence, Italy, Jun. 2016, pp. 1–6.
- [13] E. Jiménez, M. J. Carrizosa, A. Benchaib, G. Damm, and F. Lammabhi-Lagarrigue, "A new generalized power flow method for multi connected DC grids," in *Proc. Int. J. Elect. Power Energy Syst.*, vol. 74, pp. 329–337, Jan. 2016.
- [14] Q.-T. Tran, A. V. Truong, and P. M. Le, "Reduction of harmonics in grid-connected inverters using variable switching frequency," *Int. J. Elect. Power Energy Syst.*, vol. 82, pp. 242–251, Nov. 2016.
- [15] J.-C. Guan and B.-C. Chen, "Adaptive power management strategy for a four-mode hybrid electric vehicle," *J. Energy Procedia.*, vol. 105, pp. 2403–2408, May 2017.

- [16] Y. Cao, R. C. Kroeze, and P. T. Krein, "Multi-timescale parametric electrical battery model for use in dynamic electric vehicle simulations," *IEEE Trans. Transport. Electrification*, vol. 2, no. 4, pp. 432–442, Dec. 2016.
- [17] W. Shengjun, X. Qingshan, L. Qun, Y. Xiaodong, and C. Bing, "Optimal EV charging control strategy based on DC microgrid," *J. Energy Procedia*, vol. 100, pp. 243–247, Nov. 2016.
- [18] L. Tan, B. Wu, S. Rivera, and V. Yaramasu, "Comprehensive DC power balance management in high-power three-level DC-DC converter for electric vehicle fast charging," *IEEE Trans. Power Electron.*, vol. 31, no. 1, pp. 89–100, Jan. 2016.
- [19] J. Y. Yong, V. K. Ramachandaramurthy, K. M. Tan, and N. Mithulananthan, "Bi-directional electric vehicle fast charging station with novel reactive power compensation for voltage regulation," *Int. J. Elect. Power Energy Syst.*, vol. 64, pp. 300–310, Jan. 2015.
- [20] A. M. Nobrega, M. L. B. Martinez, and A. A. de Queiroz, "Investigation and analysis of electrical aging of XLPE insulation for medium voltage covered conductors manufactured in Brazil," *IEEE Trans. Dielectr. Electr. Insul.*, vol. 2, no. 2, pp. 628–640, Apr. 2013.



able energy sources and storage devices/electric cars.

ASIF KHAN received the B.Eng. degree (Hons.) in electrical engineering from the University of Hertfordshire, U.K., the B.Tech. degree in electrical and electronics engineering from the Bedford College, and the M.Sc. degree in electrical and electronics engineering from Coventry University. He is currently a Ph.D. Researcher in electrical engineering with London South Bank University. His research interests include developing an isolated smart micro grid connecting renewable energy sources and storage devices/electric cars.



SAIM MEMON received the B.Eng. degree (Hons.) in electrical engineering from the Mehran University of Engineering and Technology, the M.Sc. degree in mechatronics from Staffordshire University, and the Ph.D. degree in electrical and electronic engineering from Loughborough University. He has multi-disciplinary research and academic experiences in electrical, electronic, solar thermal, and solar energy materials engineering. He teaches HND/B.Eng./M.Eng. modules, supervises B.Eng. students' projects, and co-supervises a Ph.D. student. He is specialized in solar energy materials for sustainable low-carbon buildings, smart-grid electrical supply, and improving the energy-efficiency of thermo-electric materials with vacuum insulation for electrical power generation. He is currently a Senior Lecturer in electrical engineering with the Division of Electrical and Electronic Engineering. He has over 20 research publications in the form of journals, conferences, and newsletter. He is a fellow of HEA with a qualified teacher status by GTCS and PGCert Teaching Qualification from the University of Aberdeen.



TARIQ PERVEZ SATTAR was born in Nairobi, Kenya. He received the degree in biology, the degree in electrical and electronic engineering in U.K., and the Ph.D. degree in adaptive and self-tuning control systems from the Department of Electrical, Computer and Communications Engineering, London South Bank University. He held the posts of principal lecturer (10 years), reader (5 years), and acting head (3 years) with the Department of Electrical, Computer and Communications Engineering, London South Bank University. His expertise and teaching is in the areas of control engineering, robotics, and mechatronics. He currently leads the Robotics, Mechatronics and Non-Destructive Testing Research Group and directs the Research Centre for Automated and Robotic Non-Destructive Testing, which has been at the forefront of the development of robotic non-destructive testing.

• • •