

Received December 5, 2017, accepted January 4, 2018, date of publication January 17, 2018, date of current version February 28, 2018.

Digital Object Identifier 10.1109/ACCESS.2018.2793851

A Systematic Review of Compressive Sensing: Concepts, Implementations and Applications

MEENU RANI¹, (Student Member, IEEE), S. B. DHOK, AND R. B. DESHMUKH, (Member, IEEE)

Center for VLSI and Nanotechnology, Visvesvaraya National Institute of Technology, Nagpur 440010, India

Corresponding author: Meenu Rani (meenubanait@gmail.com)

ABSTRACT Compressive Sensing (CS) is a new sensing modality, which compresses the signal being acquired at the time of sensing. Signals can have sparse or compressible representation either in original domain or in some transform domain. Relying on the sparsity of the signals, CS allows us to sample the signal at a rate much below the Nyquist sampling rate. Also, the varied reconstruction algorithms of CS can faithfully reconstruct the original signal back from fewer compressive measurements. This fact has stimulated research interest toward the use of CS in several fields, such as magnetic resonance imaging, high-speed video acquisition, and ultrawideband communication. This paper reviews the basic theoretical concepts underlying CS. To bridge the gap between theory and practicality of CS, different CS acquisition strategies and reconstruction approaches are elaborated systematically in this paper. The major application areas where CS is currently being used are reviewed here. This paper also highlights some of the challenges and research directions in this field.

INDEX TERMS Compressive sensing, sparsity, CS acquisition strategies, random demodulator, CS reconstruction algorithms, OMP, CS applications.

I. INTRODUCTION

After the famous Shannon sampling theorem, introduction of compressive sensing (CS) is like a major breakthrough in signal processing community. CS was introduced by Donoho, Candes, Romberg, and Tao in 2004 [1]–[3]. They have developed its mathematical foundation. CS is basically used for the acquisition of signals which are either sparse or compressible. Sparsity is the inherent property of those signals for which, whole of the information contained in the signal can be represented only with the help of few significant components, as compared to the total length of the signal. Similarly, if the sorted components of a signal decay rapidly obeying power law, then these signals are called compressible signals, refer Fig.1. A signal can have sparse/compressible representation either in original domain or in some transform domains like Fourier transform, cosine transform, wavelet transform, etc. A few examples of signals having sparse representation in certain domain are: natural images which have sparse representation in wavelet domain, speech signal can be represented by fewer components using Fourier transform, better model for medical images can be obtained using Radon transform, etc. A good introduction about basis, frames and dictionaries in which the sparsest possible representation of a signal can be obtained, is available in

articles [12]–[16]. Acquisition of sparse signals using traditional methods requires: i) sampling using Nyquist-criterion, which results in too many samples compared to the actual information contents of the signal, ii) compressing the signal by computing necessary transform coefficients for all the samples, retaining only larger coefficients and discarding the smaller ones for storage/transmission purposes. Addressing the question “why to take too many samples, when most of them are to be discarded?”, CS simplifies the signal acquisition by taking far fewer random measurements. Fig.2 depicts the comparison between traditional sampling and CS sampling schemes.

Another limitation of sampling using Nyquist-rate is that the rate at which sampling has to be done, may not be practical always. For example, in case of multiband signals having wide spectral range, sampling rate suggested by Nyquist-criterion may be orders of magnitude higher than the specifications of best available analog-to-digital converter (ADC). The sampling rate using Nyquist-criterion is decided by the highest frequency component present in signal, whereas, sampling rate in CS is governed by the signal sparsity. The CS measurements are non-adaptive, *i.e.*, not learning from previous measurements. The resulted fewer compressive measurements can be easily stored or transmitted. This

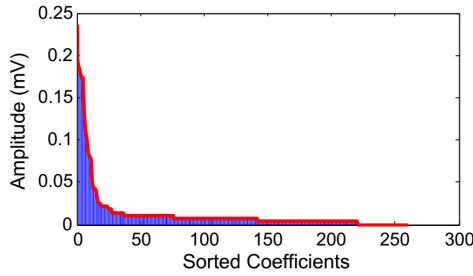

FIGURE 1. Rapid decay of coefficients of a signal when represented using suitable transform, obeying power law.

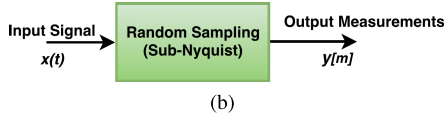
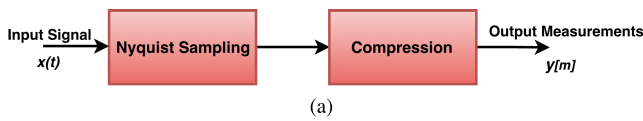

FIGURE 2. A comparison of sampling techniques: (a) traditional sampling, (b) compressive sensing.

gives an impression of compressing the signal at the time of acquisition only and hence the name ‘Compressive Sensing’. CS allows the faithful reconstruction of the original signal back from fewer random measurements by making use of some non-linear reconstruction techniques. Because of all these features, CS finds its applications especially in the areas i) where, number of sensors are limited due to high cost, e.g., non-visible wavelengths, ii) where, taking measurements is too expensive, e.g., high speed A/D converters, imaging via neutron scattering, iii) where, sensing is time consuming, e.g., medical imaging, iv) where, sensing is power constrained, etc. [4]–[7].

Motivation and Contribution: Although, there are other good survey papers, like, [160], [161], available in literature in the area of CS, this area lacks a systematic review paper, which covers both theory and implementations, for a smooth transition from theory to practicality. Also the current research areas and the challenges encountered in the field, needs to be surveyed to further boost the research in this area. This paper tries to cover the above mentioned aspects and also present some related future scopes. As far as the theoretical aspects of CS are concerned, the field of CS is equipped with rigorous mathematical analysis and proofs, which are not easy to grasp. After an in-depth literature survey, the important concepts underlying CS, are briefed here, in an easy to understand manner.

A. ACQUISITION MODEL

CS works by taking fewer random measurements which are non-adaptive. The CS acquisition model can be described

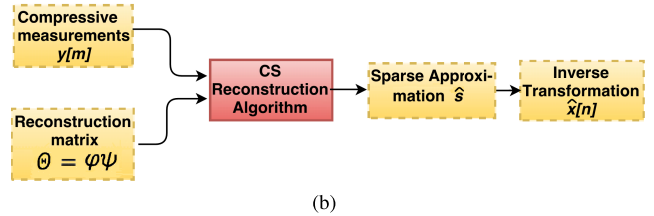
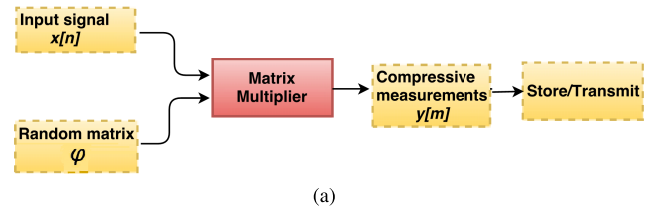

FIGURE 3. CS Model: (a) acquisition model, (b) reconstruction model.

mathematically by (1) and is shown in Fig.3(a).

$$y = \varphi x, \tag{1}$$

where, $x \in \mathbb{R}^n$ or \mathbb{C}^n is an input signal of length n , $\varphi \in \mathbb{R}^{m \times n}$ or $\mathbb{C}^{m \times n}$ is an $m \times n$ random measurement matrix and $y \in \mathbb{R}^m$ or \mathbb{C}^m is the measurement vector of length m . The Input signal and the random measurement matrix are multiplied together to generate compressive measurements. Here, the number of measurements taken are much lesser than the length of input signal, i.e., $m \ll n$. The size of measurement matrix and hence the number of measurements is proportional to the sparsity of input signal. To further reduce the number of measurements which are necessary for perfect reconstruction, the measurement matrix must be incoherent with basis in which signal has sparse representation [4], [5], [8].

B. RECONSTRUCTION MODEL

The CS reconstruction model is shown in Fig.3(b). The inputs to the reconstruction algorithm are the measurement vector y and reconstruction matrix Θ , where $\Theta = \varphi \times \psi \in \mathbb{R}^{m \times n}$ or $\mathbb{C}^{m \times n}$ and ψ is the sparsifying basis of the signal x . The signal x can be represented as a linear combination of columns of ψ or the basis vectors as

$$x = \sum_{i=1}^n s_i \psi_i = \psi s, \tag{2}$$

where, $s \in \mathbb{R}^n$ is the sparse coefficient vector of length n , having fewer significant/nonzero entries. The original signal can be recovered back from compressive measurements by solving (1), which is an underdetermined system of linear equations and have infinite number of possible solutions. In such cases, the unique solution can be obtained by posing the reconstruction problem as an ℓ_0 -optimization problem given by (3). The ℓ_0 -optimization problem searches for a solution having minimum ℓ_0 -norm subject to the given constraints. This is equivalent to trying all the possibilities to find the desired solution [4], [5], [8].

$$\hat{s} = \arg \min_s \|s\|_0 \quad \text{subject to } \Theta s = y, \tag{3}$$

where \hat{s} is the estimate of s and $\|s\|_0$ denotes the ℓ_0 -norm of s . Although ℓ_0 is not a proper norm, it is a pseudonorm or quasi-norm, which represents the number of non-zero elements of a vector [17]. Searching for a solution of (3) by trying all possible combinations is computationally extensive exercise even for a medium sized problem. Hence, ℓ_0 -minimization problem has been declared as NP-hard. Alternates have been proposed in literature, which are capable of obtaining a solution similar to the ℓ_0 -minimization for the above problem, in near polynomial time. One of the options is to use convex optimization and searching for a solution having minimum ℓ_1 -norm, as given by (4). This is considered as a feasible option because solvers available from linear programming can be used for solving the ℓ_1 -minimization problems in near polynomial time.

$$\hat{s} = \arg \min_s \|s\|_1 \quad \text{subject to } \Theta s = y, \quad (4)$$

where $\|s\|_1$ denotes the ℓ_1 -norm of s , which represents the absolute sum of elements of a vector. The generalized expression of a norm is given by (5), from which definition of ℓ_1 and other relevant norms can be obtained wherever required [17].

$$\ell_p : \|x\|_p = \sqrt[p]{\sum_i |x_i|^p}. \quad (5)$$

The output of CS reconstruction algorithm is an estimate of sparse representation of x , i.e., \hat{s} . The estimate of x , i.e., \hat{x} can be obtained from \hat{s} by taking its inverse transform [10], [11], [28].

C. NECESSARY AND SUFFICIENT CONDITIONS FOR PERFECT RECOVERY

1) RESTRICTED ISOMETRY PROPERTY (RIP)

Let k be the sparsity of vector s , then necessary condition for recovering s from measurements y is that the matrix Θ must obey RIP of order k , as given in (6).

$$1 - \delta \leq \frac{\|\Theta u\|_2}{\|u\|_2} \leq 1 + \delta, \quad (6)$$

where u is a vector having the same k -nonzero entries as s and $\delta > 0$ is known as restricted isometry constant [4]. This inequality states that matrix Θ must preserve the distance between two k -sparse vectors. However, a sufficient condition for a robust solution is that matrix Θ must satisfy relation given by (6) for an arbitrary $3k$ -sparse vector u . It has been found in literature that calculating δ is itself a very tough task, so another simpler condition which guarantees stable solution is incoherence [8], [9].

2) INCOHERENCE

This condition states that for faithful reconstruction, the measurement basis φ and sparse basis ψ must be incoherent from each other. The relation for finding the coherence between two matrices is given in (7). This is a measure of maximum correlation among any two elements of given pair of matrices.

$$\mu(\varphi, \psi) = \sqrt{n} \max_{1 \leq i, j \leq n} |\langle \varphi_i, \psi_j \rangle|. \quad (7)$$

TABLE 1. Number of required compressive measurements.

Matrix type	Number of measurements
i.i.d. Gaussian and Bernoulli	$m \gtrsim ck \log n/k$
Partial Fourier	$m \gtrsim c\mu k(\log n)^4$
Any other random	$m \approx O(k \log n)$
Deterministic	$m \approx O(k^2 \log n)$

The range of coherence is $\mu(\varphi, \psi) \in [1, \sqrt{n}]$ [5]. In case of partial Fourier sensing matrix, the relation of coherence, μ , with number of measurements, m , is given in Table 1. This dependency shows that a lower value of coherence is desired, which in turn lowers the number of measurements required for CS reconstruction. A few examples of incoherent pairs of basis are spikes and Fourier, wavelets and noiselets, spikes and sinusoids, etc. [7], [8].

D. MEASUREMENT MATRICES AND NUMBER OF MEASUREMENTS

A proper selection of measurement matrix, φ is the key to the success of CS. The general measurement matrices used in CS are the random matrices drawn from i.i.d. Gaussian or Bernoulli distribution and partial Fourier matrices, etc. It has been proved in literature that these random matrices are incoherent with any other basis, as well as obeys the RIP condition of perfect recovery. If φ has Gaussian distribution and ψ belongs to an orthonormal basis, then matrix $\Theta = \varphi\psi$, will also have Gaussian distribution and hence will be able to recover exact solution with high probability [8]. The number of measurements required for faithful reconstruction for particular choice of measurement matrix are given in Table 1, where c is a positive constant [6], [7].

Although, the CS has been proposed along with random measurement matrices. But the problem with random matrices is that we can't store and reproduce them at receiver. It means that these matrices needs to be transmitted along with the signal, which is not practical for signal processing applications. So the research interest has been diverted towards the design of deterministic and structured measurement matrices that can be used as CS measurement matrices. Examples of such matrices are circulant, toeplitz, structured random matrices, etc., which has made it possible to use CS for practical applications. The advantages of structured random matrices are faster acquisition, lesser storage requirement, reproducibility and reduced transmission overhead, while the drawback is the requirement of higher number of measurements compared to random matrices [53]–[55].

This section has presented the theoretical concepts of CS in a simplified manner. Now, relating theory to practicality, a systematic review of implementation aspects of CS is presented in next sections. Section II reviews the acquisition techniques proposed in literature, for the sampling a signal using CS. Section III presents the CS reconstruction approaches with a discussion on popular algorithms under

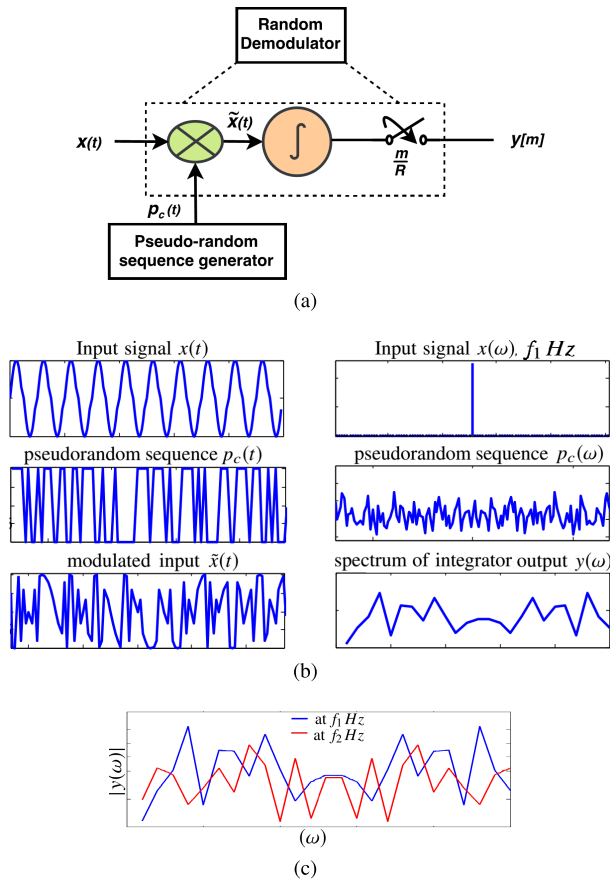

FIGURE 4. CS acquisition using RD technique. (a) Block diagram of RD. (b) Input-output waveforms generated at each stage. (c) Unique frequency signatures obtained after integrator stage for two different frequencies f_1 Hz and f_2 Hz.

each category. A comparison of reconstruction approaches is also presented, which will help readers to choose a suitable reconstruction approach for a particular application in hand. Section IV categorizes the prominent application areas where CS is currently being used, along with the basic idea behind some of the areas. Section V discusses some of the challenges and associated research opportunities in this field.

II. CS ACQUISITION STRATEGIES

The main requirement of CS for proper reconstruction is that the measurements must be taken randomly. To meet this requirement, different techniques has been proposed in literature. This section summarizes the operating principle of these acquisition techniques.

A. RANDOM DEMODULATOR

Random demodulator (RD), proposed by Laska *et al.*, in 2007, is a compressive sampler used to sample signals at a rate below the Nyquist. RD shown in Fig.4(a), also termed as analog to information converter (AIC), is an efficient wideband signal sampler. The input signal $x(t)$ is first multiplied with a pseudorandom sequence consisting of $+/-$ 1s, known as chipping sequence $p_c(t)$. This is equivalent to the

convolution in frequency domain and results in spreading the signal frequency to low frequency regions, as shown in Fig.4(b). The next stage is an integrator, serving as a low pass filter (LPF), which is used to obtain a unique frequency signature of signal in lower frequency region. Fig.4(c) shows the unique frequency signatures, obtained from RD, for two different frequency signals. Now, the highest frequency of the signal so obtained lies in lower frequency region and hence can be sampled using a low rate ADC to obtain vector of digital measurements. These fewer compressive measurements can be easily then be stored or transmitted. The unique frequency signature is the information about the original signal that is contained in random measurements and helps in reconstructing the original signal back from compressive measurements.

In matrix form the operation of the RD can be described by two matrices P and H , shown in (8). The matrix P is an $n \times n$ diagonal matrix of chipping sequence, having elements $p_i \in +/- 1$ and H is an $m \times n$ accumulate and dump matrix serving as an integrator. The number of ones in each row of matrix H determines the number of samples to be accumulated for one measurement and are generally given by the ratio $R = \lfloor n/m \rfloor$. In (9), \tilde{x} is the result of multiplying x with pseudorandom sequence of $+/-$ 1s, \tilde{x} is further multiplied by H to obtain the measurement vector y . Here, φ can be considered as the product of two matrices H and P [18], [19].

$$P = \begin{bmatrix} p_1 & & \\ & \ddots & \\ & & p_n \end{bmatrix}; \quad H = \begin{bmatrix} 111 \dots & & \\ & 111 \dots & \\ & & 111 \dots \end{bmatrix} \quad (8)$$

$$\left. \begin{aligned} \tilde{x} &= Px \\ y &= H\tilde{x} = \varphi x \\ \varphi &= HP \end{aligned} \right\} \quad (9)$$

In case of RD, the minimum number of measurements required for perfect reconstruction are $O(k \log W/k)$, where k is the sparsity and W is the Bandwidth of signal x .

B. MODULATED WIDEBAND CONVERTER (MWC)

MWC was proposed by Mishali and Eldar [21], in 2010. This is a parallel architecture and is used for sampling sparse wideband signals, like multiband signals. The block diagram of MWC is shown in Fig.5. The input signal $x(t)$ is applied to all the channels simultaneously, which is then multiplied with the different chipping sequence in each channel, *i.e.*, $p_{c1}(t)$, $p_{c2}(t)$ upto $p_{cN}(t)$. This results in spreading the spectral portion from each band to the baseband. This signal is passed through a low pass filter and then sampled at a rate much below the Nyquist. If the cutoff frequency of the filter is say $\frac{1}{2T_s}$, then the sampling rate will be $\frac{1}{T_s} \ll f_{Nyq}$ and depends on B , the width of single band of $x(t)$. The overall sampling rate is $N \times f_s$, where, N is the number of channels and f_s is the per channel sampling frequency. A sufficiently large number of low rate band mixtures $y_1[m]$ to $y_N[m]$, allows to recover a sparse multiband signal $x(t)$. MWC construct

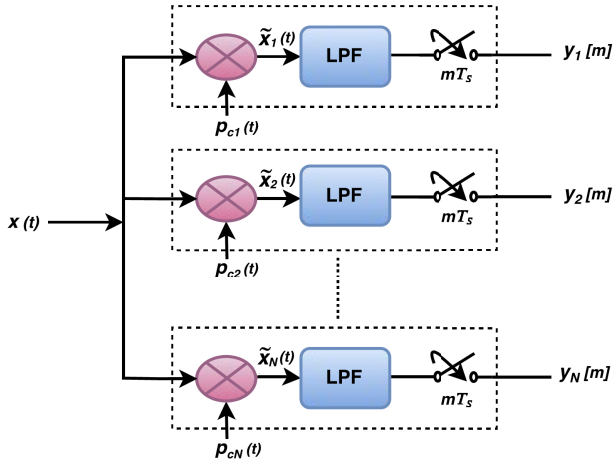

FIGURE 5. CS acquisition using MWC technique.

the reconstruction model in frequency domain and solves the ℓ_1 block sparsity problem periodically, to find the bands of spectrum having non-zero power content. Compared to RD, this architecture is faster and easier to implement.

C. RANDOM MODULATION PRE-INTEGRATOR (RMPI)

RMPI was proposed by Yoo et al., in 2012. This architecture is similar to MWC and is the paralleled version of RD. This is being utilized for sampling ultrawideband (UWB) signals. A simplified version of RMPI is shown in Fig.6. The UWB input signal $x(t)$ is first divided into different frequency bands. Each channel of RMPI selects a particular frequency band from input signal with the help of frequency selective filters. The selected frequency band is then multiplied with a different chipping sequence in each channel, i.e., $p_{c1}(t)$ to $p_{cN}(t)$. After integrating and sampling, N sets of measurement vectors $y_1[m]$ to $y_N[m]$ are generated in parallel. Different from MWC, RMPI uses integrator in place of LPF, which plays an important role in differing their reconstruction method. Compared to RD, this architecture allows further reduction in sampling rate by the amount of parallelism used.

D. RANDOM FILTERING

This technique was proposed by Tropp et al. [22], in 2006. The input signal x , is acquired by performing convolution with a random-tap finite impulse response (FIR) filter h . The first stage is then followed by downsampling the filtered signal by a factor of $\lfloor n/m \rfloor$ to obtain compressive measurements y , as shown in Fig.7. The filter taps are random and can be obtained from random distributions like Gaussian distribution $\mathcal{N}(0, 1)$ with zero mean and variance one, Bernoulli distribution of $+/-1$ s. This technique is applicable for compressible, continuous and streaming signals.

E. RANDOM CONVOLUTION

This measurement strategy was proposed by Romberg [23], in 2009. In this technique, the first row of measurement matrix φ consists of random pulses. Then, next row is

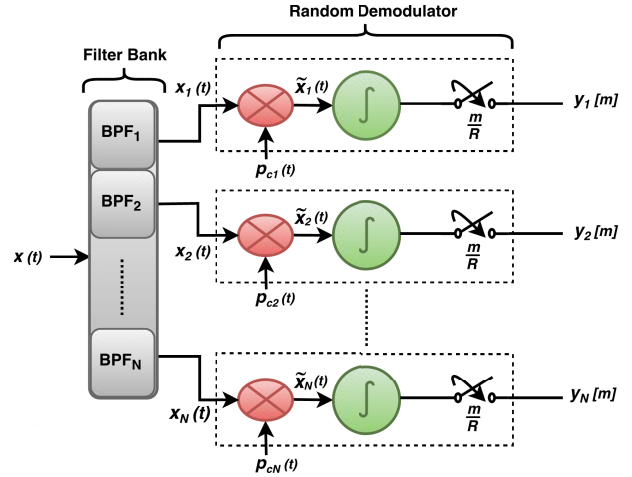

FIGURE 6. CS acquisition using RMPI technique.

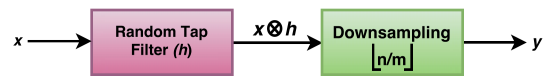

FIGURE 7. CS acquisition using random filter technique.

obtained by circular shift of a previous row. This procedure is repeated for all other rows to generate measurement matrix. The measurement matrix so generated, is then convolved with the input signal x to obtain the measurement vector $y = \varphi * x$. This matrix is a structured random matrix and have advantages like faster acquisition, easy storage and transmission. It has been shown as a universal sampling method, i.e. incoherent with any fixed orthobasis.

F. COMPRESSIVE MULTIPLEXER

Slavinsky et al. [24], in 2011 proposed another parallel architecture for signal acquisition using CS, known as compressive multiplexer (CMUX). Exploiting the joint signal sparsity, this architecture samples the multichannel data using single ADC operating at sub-Nyquist-rate, as shown in Fig.8. In each channel, the baseband signal is obtained from conventional RF tuner, which is then smeared in frequency by multiplying random chipping sequences $p_{c1}(t)$ to $p_{cN}(t)$, where N is the number of channels required to sample the given bandwidth B . The number of channels can be upper bounded by $N \leq \frac{B}{k} \frac{1}{c(\log B)^4}$, where $B = NW$. The modulated signals are then summed across the channels and sampled once per chip by single ADC operating at Nyquist-rate. This multiplexed signal is recovered via multi-channel separation.

G. RANDOM EQUIVALENT SAMPLING (RES)

This is another technique which is based on random sampling mechanism. This is being used to sample the periodic high frequency analog signals at sub-Nyquist-rate. The use of CS reconstruction for the signals acquired using RES, was proposed by Zhao et al. [25], in 2011. CS reconstruction for RES achieves higher SNR while requiring fewer RES samples

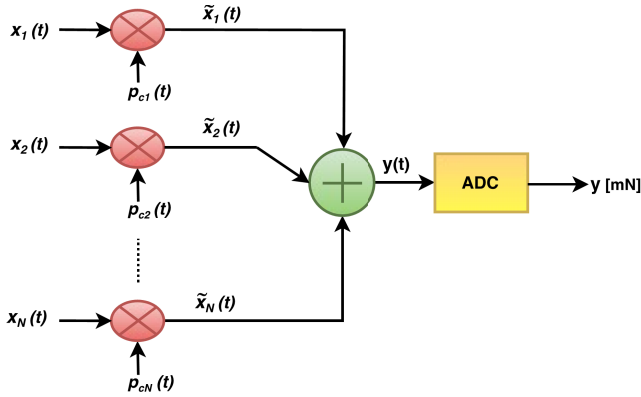

FIGURE 8. CS acquisition using CMUX technique.

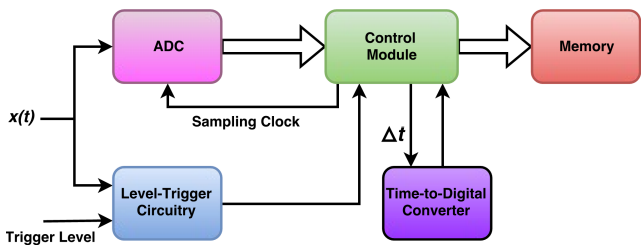

FIGURE 9. CS acquisition using RES technique.

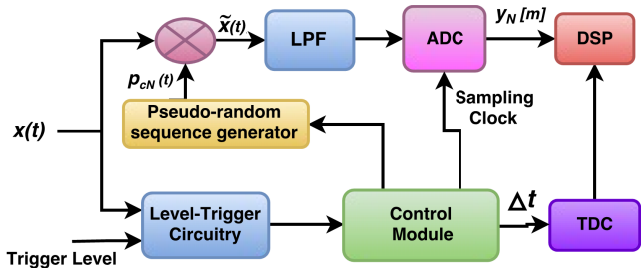

FIGURE 10. CS acquisition using RT-MWCS technique.

compared to the traditional method. The block diagram of signal acquisition using RES is shown in Fig.9. RES samples the signal at random positions by dithering the phase of ADC sampling clock with the help of a variable delay circuitry implemented using the control module. A level-triggering circuitry is used to provide fixed reference trigger-pulses to the control module to align the samples. The time-to-digital converter (TDC) circuitry is used to measure the relative sample positions, which are required to generate the measurement matrix using Whittaker-Shannon interpolation formula. The measurement matrix so generated is used for applying the CS reconstruction on RES sampled signal.

H. RANDOM TRIGGERING-BASED MODULATED WIDEBAND COMPRESSIVE SAMPLING (RT-MWCS)

RT-MWCS was proposed by Zhao et al. [26], in 2016, for sparse multiband signals. The block diagram of RT-MWCS is shown in Fig.10. Compared to MWC, this is a single

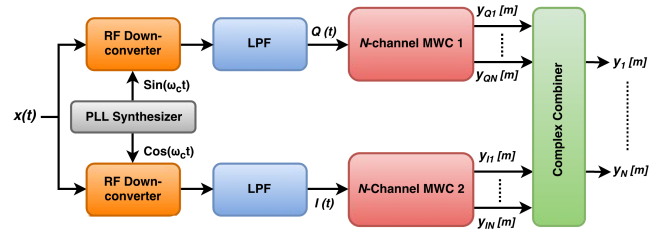

FIGURE 11. CS acquisition using QAIC technique.

channel architecture, which requires multiple runs of acquisition. Once triggered, the input signal $x(t)$ is first multiplied with a pseudorandom sequence consisting of $+/- 1$ s. After low pass filtering the multiplied signal $\tilde{x}(t)$, the signal is sampled at random positions using RES mechanism. For reconstruction, a multiple measurement vector (MMV) method is used to estimate the sparse multiband signal in frequency domain. RT-MWCS has simple architecture and is not subjected to the ADC bandwidth barrier. The disadvantage of this scheme is the more time required for acquisition.

I. QUADRATURE ANALOG-TO-INFORMATION CONVERTER (QAIC)

QAIC was proposed by Haque et al. [27], in 2014. This is a bandwidth flexible and spectrum blind approach for wideband sensing. The bandwidth flexibility and improved energy efficiency are achieved at the cost of increased complexity, compared to MWC. The block diagram of QAIC is shown in Fig.11. The input signal $x(t)$, is first downconverted and low pass filtered to restrict the RF bandwidth. The two outputs $Q(t)$ and $I(t)$ of downconverter, are then passed through the two N -channel MWCs separately. The downconversion allows us to use short and low frequency pseudorandom sequences during signal randomization step of MWC. The outputs of MWCs are the given to a pairwise complex combiner to select either upper or lower band cluster and to generate N outputs $y_1[m]$ to $y_N[m]$.

The important features of all CS acquisition strategies are summarized in Table 2. This may be helpful in selecting an acquisition technique for a particular application, since, acquisition strategies seems to be signal dependent.

III. CS RECONSTRUCTION APPROACHES

CS reconstruction algorithms try to find out the sparse estimation of the original input signal, from compressive measurements, in some suitable basis or frame or dictionary. A lot of research has been done on this aspect of CS, to come up with better performing algorithms. The research driving factors in this area are ability to recover from minimum number of measurements, noise robustness, speed, complexity, performance guarantees, etc. [8]. The CS reconstruction algorithms are mainly classified under six approaches, as shown in Fig.12. This section summarizes the popular algorithms under each approach.

TABLE 2. Summary of CS acquisition strategies.

Acquisition Strategy	Measurement Type used	Measurement Constraint	Features	Application
RD	Pseudorandom	$m \approx O(k \log W/k)$	<ul style="list-style-type: none"> -Serial Architecture - Easy to implement 	Wideband signal acquisition
MWC	Pseudorandom	$N \approx 4M \log(L/2M)$ $N \Rightarrow$ number of channels $M \Rightarrow$ number of bands $L \Rightarrow$ length of PRBS	<ul style="list-style-type: none"> -Parallel Architecture - Multi ADCs - faster and easier to implement compared to RD - reconstruction requires solution of ℓ_1 block sparsity problem periodically 	Wideband signal acquisition
RMPI	Pseudorandom	$m \gtrsim c\mu^2 k(\log n)^5$	<ul style="list-style-type: none"> -Parallel Architecture - Multi ADCs - Sampling rate decreases as order of parallelism increases 	UWB signal acquisition
Random Filtering	Random Gaussian or Bernoulli	$m \gtrsim ck \log n/k$	<ul style="list-style-type: none"> - Serial Architecture - Easy to implement 	Streaming and compressible signal acquisition
Random Convolution	Structured Random	$m \gtrsim ck(\log n)^5$	<ul style="list-style-type: none"> -Serial Architecture -Requires full knowledge of signal beforehand 	Universal Acquisition strategy
CMUX	Pseudorandom	$N \leq \frac{B}{k} \frac{1}{c(\log B)^4}$ $N \Rightarrow$ number of channels	<ul style="list-style-type: none"> - Parallel Architecture - Single ADC - Exploits joint sparsity 	Multi-channel data acquisition
RES	Random position based	$T_s = Q \cdot T_0 + T_s \pmod{T_0}$ $T_s \Rightarrow$ sampling period $T_0 \Rightarrow$ fundamental period	<ul style="list-style-type: none"> -Serial Architecture -single ADC -stores sample positions 	high frequency analog signal acquisition
RT-MWCS	Pseudorandom+Random position based	Runs of acquisition $\approx 4M \log(L/2M)$	<ul style="list-style-type: none"> -Serial Architecture - Single ADC - low complexity - higher acquisition time - uses MMV method for reconstruction 	Wideband signal acquisition
QAIC	Pseudorandom	$N \approx 4M \log(2L/M)$	<ul style="list-style-type: none"> -Parallel Architecture - improved energy efficiency - bandwidth flexibility - higher complexity 	Wideband signal acquisition

A. CONVEX OPTIMIZATION APPROACH

This approach poses the CS reconstruction problem as a convex optimization problem which can be solved by utilizing solver from linear programming. The convex formulations proposed in literature, for obtaining the sparse representation of a signal, are discussed below:

1) BASIS PURSUIT

Basis Pursuit (BP) was proposed by Chen *et al.* [28], in 1999 . It is a convex optimization problem, which searches for a solution having minimum ℓ_1 -norm, subject to the equality constraint given in (10).

$$\hat{s} = \arg \min_s \|s\|_1; \quad \text{subject to } \Theta s = y. \quad (10)$$

BP is used in CS to find the sparse approximation \hat{s} of input signal x , in dictionary or matrix Θ , from compressive measurements y . BP can recover faithfully only if, the measurements are noise-free.

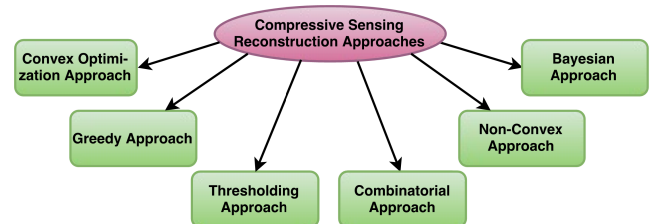

FIGURE 12. CS reconstruction approaches.

2) DENOISING USING CONVEX APPROACH

If the measurements are corrupted by noise, then to suppress the noise, exact reconstruction is not desired. The denoising can be achieved by relaxing the equality constraint in (10) to account for measurement noise. The widely used formulations for robust data recovery from noisy measurements are Dantzig selector, basis pursuit denoising (BPDN), total variation (TV) minimization based denoising, etc.

- **Basis Pursuit Denoising:** BPDN was introduced by Chen et al. [28], in 1999, in the field of computational harmonics. This is same as Least Absolute Shrinkage Selection operator (LASSO), which was introduced by Tibshirani [30] in 1996, in statistics. To account for the noise in measurements, BPDN poses the sparse estimation problem, as an optimization problem given by (11). It shows that, BPDN searches for a solution having minimum ℓ_1 -norm subject to the relaxed condition on constraint. The quadratic inequality constraint used by BPDN states that for the obtained solution, the squared ℓ_2 -norm of the error between y and Θs should be less than or equal to ϵ .

$$\hat{s} = \arg \min_s \|s\|_1; \quad \text{subject to } \frac{1}{2} \|y - \Theta s\|_2^2 \leq \epsilon, \quad (11)$$

where, ℓ_2 , also known as euclidean norm, represents the length or size of a vector [17]. Some algorithms solve BPDN in its Lagrangian form, which is an unconstrained optimization problem and can be rewritten as in (12).

$$\hat{s} = \arg \min_s \lambda \|s\|_1 + \frac{1}{2} \|y - \Theta s\|_2^2. \quad (12)$$

Equations (11) and (12) are equivalent for certain value of λ , which is unknown a priori. Value of λ balances between error and sparsity of solution. Popular algorithms that has been used to solve (12) are primal-dual interior-point method, fixed-point continuation, etc. A slightly different version of BPDN posed by LASSO in constrained form is (13).

$$\hat{s} = \min_s \frac{1}{2} \|y - \Theta s\|_2^2; \quad \text{subject to } \|s\|_1 \leq \epsilon. \quad (13)$$

- **Dantzig Selector:** This formulation was introduced by Candès and Tao [29] in 2007. They tackled the noise in measurements by posing the sparse estimation problem, as an optimization problem given by (14). Dantzig searches for a solution having minimum ℓ_1 -norm subject to the constraint that the squared ℓ_∞ -norm of the error between y and Θs should be less than or equal to ϵ .

$$\hat{s} = \arg \min_s \|s\|_1; \quad \text{subject to } \frac{1}{2} \|y - \Theta s\|_\infty^2 \leq \epsilon, \quad (14)$$

where, ℓ_∞ -norm is defined as $\|x\|_\infty = \max_i |x_i|$ and represents the max value in array [17].

- **Total Variation Denoising:** TV norms are the ℓ_1 -norms of derivatives. This method was originally proposed for image denoising by Rudin et al. [31], in 1992. This searches for a solution having minimum total variation among its components, subject to the constraint of keeping squared norm of error less than or equal to ϵ . The constraints of this optimization program (15) are determined by signal statistics, which allows noise removal.

$$\hat{s} = \arg \min_s \|s\|_{TV}; \quad \text{subject to } \frac{1}{2} \|y - \Theta s\|_2^2 \leq \epsilon. \quad (15)$$

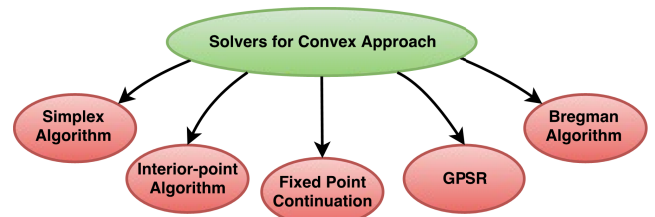

FIGURE 13. Solvers used for solving convex optimization problem of CS reconstruction.

3) SOLVERS FOR CONVEX APPROACH

Solvers are required to solve the optimization problems described above. The BP problem in (10) can be solved by linear programming algorithms like simplex algorithm known as BP-simplex, interior-point algorithm known as BP-interior. Here, simplex can be defined as a convex polyhedron formed by the set of all feasible solutions (points) [28]. Apart from simplex and interior-point algorithms, the other popular algorithms for solving convex optimization problems are fixed point continuation (FPC), gradient projection for sparse representation (GPSR), Bregman iteration algorithm, etc. Fig.13 shows some popular solvers for solving the convex optimization problems. The algorithmic steps of these solvers are described below:

- **BP-Simplex Algorithm:** The basic steps for solving the BP problem using simplex algorithm are shown in Fig.14(a) and are described below:
 - Initial basis selection: initial basis are a set of n linearly independent columns selected from a dictionary. Using initial basis, find the initial feasible solution, which corresponds to one of vertices of the simplex.
 - Swapping: swap one column in current basis with the column not in the basis that gives best improvement in objective function. This is equivalent to jumping on the vertices of simplex for searching the solution, in the direction of improving the objective function.
 - Repeat step ii), until no further improvement is possible. At last, the optimal solution is achieved.
- **BP-Interior Algorithm:** The basic steps for solving the BP problem using interior-point algorithm are shown in Fig.14(b) and are described below:
 - Initial solution: start from a non-sparse initial solution which is well inside the interior of simplex.
 - Apply transformation that sparsifies the solution. This corresponds to moving the solution inside the simplex in the direction of reaching to a vertex.
 - Repeat step ii), until a solution having $\leq n$ significant non-zero entries, is reached. The result so obtained is a feasible solution and corresponds to the vertex of simplex.
- **Fixed Point Continuation Algorithm:** FPC was proposed by Hale et al. [32], in 2007. It solves the unconstrained formulation of ℓ_1 -minimization problem of the type (12) or (16).

$$\hat{s} = \arg \min_s \lambda \|s\|_1 + G(s), \quad (16)$$

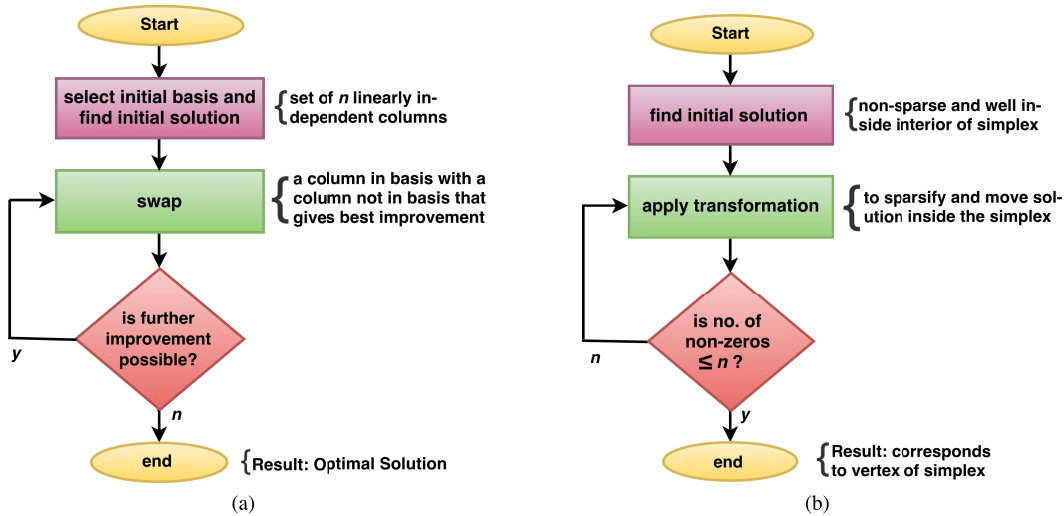

FIGURE 14. Algorithmic steps of solvers for basis pursuit namely: (a) simplex method and (b) interior-point method.

where G is convex and differential. For noisy case G can be $\|(y - \Theta s)\|_2^2$. Selection of parameter λ has an impact on solution, which may be chosen by trial and error. FPC uses shrinkage based iterative procedure shown in (17) for solving the convex optimization problem given in (16).

$$s_i^{t+1} = \text{shrink}((s^t - \tau \nabla G(s^t))_i, \mu \tau), \quad (17)$$

where, the shrinkage operator for scalar components can be defined as in (18). The other parameters like $\tau > 0$, decides the step size of gradient descent and μ decides the allowable distance between s^{k+1} and s^k .

$$\text{shrink}(u, \beta) = \begin{cases} u - \beta & \text{if } u > \beta \\ 0 & \text{if } -\beta \leq u \leq \beta \\ u + \beta & \text{if } u < -\beta. \end{cases} \quad (18)$$

- **Gradient Projection for Sparse Representation:** GPSR proposed by Figueiredo et al. [33], in 2007, also solves the unconstrained formulation of ℓ_1 -minimization problem of the type (12) or (16). GPSR makes use of backtracking line search and updates in the negative gradient direction for finding the solution. The updates performed in each iteration of GPSR are given in (19), which are repeated until the convergence criteria is met.

$$\left. \begin{aligned} w^t &= (s^t - \alpha^t \nabla F(s^t))_+ \\ s^{t+1} &= s^t + \lambda^t (w^t - s^t) \end{aligned} \right\}, \quad (19)$$

where, $\alpha^t > 0$ and $\lambda^t \in [0, 1]$ are some scalar parameters and $F(\cdot)$ is the function to be minimized in the optimization problem.

- **Bregman Iteration Algorithm:** For solving the constrained optimization problem in (10), Osher et al. [34], proposed a method in 2005, known as Bregman iteration algorithm. This iteratively solves a small number of unconstrained problems, known as Bregman Iterations,

given in (20). It gives a faster and stable solution to the ℓ_1 -minimization problem. Other improved versions of this algorithm are linearized Bregman algorithm [35], Split Bregman algorithm [36], etc.

$$\left. \begin{aligned} y^{t+1} &= y^t + y - \Theta s^t \\ s^{t+1} &= \arg \min_s \|s\|_1 + \frac{1}{2} \|(\Theta s - y^{t+1})\|_2^2 \end{aligned} \right\}. \quad (20)$$

B. GREEDY APPROACH

The convex optimization approach presented above is a global optimization method. Different from that, the greedy approach is a step-by-step iterative method. In each iteration, the solution is updated by selecting only those columns of reconstruction matrix, which are highly correlated with the measurements. The selected columns are called atoms. Generally, the atoms selected once, are not included in subsequent iterations of the algorithm. This idea lowers the computational complexity of the algorithm. Here, the solution is approached in a greedy fashion and hence, the name. The advantages of this approach are simple operation, low computational complexity and faster execution. Drawback is, it requires knowledge of sparsity of the underlying signal, before hand [8]. The algorithms that work on this approach can be further classified into two categories:

1) SERIAL GREEDY ALGORITHMS

The algorithms that can be put under this category are matching pursuit (MP) proposed by Mallat and Zhang [37], in 1993, orthogonal matching pursuit (OMP) proposed by Y. C. Pati et al. [38], in 1993 and gradient pursuit (GP) proposed by Bluemensath and Davies [39], in 2008. Each iteration of these algorithms selects only one atom in each iteration and computes the corresponding non-zero entry of solution vector. Therefore, these algorithms are termed as serial greedy algorithms. The basic steps of these algorithms are described below and are shown in Fig.15. All the steps

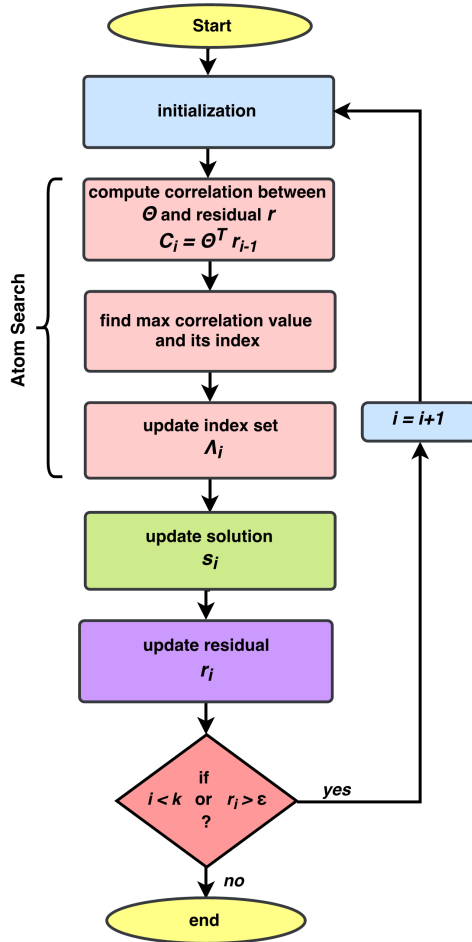

FIGURE 15. Algorithmic steps of serial greedy algorithms.

same for the three algorithms, except the update solution step, as outlined below:

- **Initialization:** The vector r , an $m \times 1$ residual vector is initialized with measurement vector y . Vector s , an $n \times 1$ solution set and index set Λ of size $m \times 1$ are initialized to null vector. Iteration counter, i is initialized to 1.
- **Atom Search:** This step finds a column of reconstruction matrix which is maximally correlated with the residual vector r . Position of that atom of Θ is updated in the index set or active set Λ . Here, Θ^T is the transpose of matrix Θ .
- **Update sparse solution:** Corresponding to the selected atoms of Θ , the solution set s_i is updated. The method of updating the solution set is described below, which is different for all the algorithms in this category.
 - In MP, the direct update is performed by directly adding the previous solution s_{i-1} , with the maximum correlation value C_{θ_i} , of current iteration, using a unit vector U_{θ_i} . The unit vector U_i consists of a 1 at position θ_i and rest of the entries are zero.
 - In OMP, the solution set is updated using least square method. This gives a solution, which

best fits the subspace, spanned by selected atoms of Θ .

- iii). GP updates the solution set in gradient direction.
- **Update residual:** New residual is calculated by subtracting product $\Theta_{\Lambda_i} s_i$ from measurement vector y . These steps are repeated either k times or until the desired value of the residual is reached.

2) PARALLEL GREEDY ALGORITHMS

The algorithms that can be put under this category are compressive sampling matching pursuit (CoSaMP) and subspace pursuit (SP). Instead of selecting only one atom from matrix Θ , these algorithms operate by selecting k or multiple of k atoms at a time and hence termed as parallel greedy pursuits. Rest of the steps are same as described for serial greedy algorithms. These algorithms are more powerful than serial counterparts, because they have the capability of removing the wrong atoms selected during previous iterations. The main differences between CoSaMP and SP are given below:

- **CoSaMP:** CoSaMP was proposed by Needell and Tropp [40] in 2009. Each iteration of CoSaMP selects $2k$ columns of Θ , which are maximally correlated with the residual vector. These $2k$ atoms are then added with k atoms of previous iteration. Out of these $3k$ atoms, the best k atoms are retained after least square step of finding the best fit for sparse vector s . Then, the positions of these atoms is updated in the active set Λ .
- **Subspace Pursuit:** SP was proposed by Dai and Milenkovic [41] in 2009. SP selects k atoms in each iteration, compared to $2k$ atoms by CoSaMP, which in turn reduces its complexity. The larger restricted isometry constant is required to guarantee convergence in case of SP as compared to CoSaMP.

C. THRESHOLDING APPROACH

The algorithms under this category, operates on k atoms of Θ , simultaneously. This approach uses some thresholding operation to update the solution set s_i . Rest of the steps are similar to greedy algorithms. Some of the popular algorithms that use this approach are iterative hard thresholding (IHT), iterative soft thresholding (IST), approximate message passing (AMP), etc.

1) ITERATIVE HARD THRESHOLDING ALGORITHM

This algorithm was proposed by Blumensath and Davies [42], in 2009. This uses a non-linear thresholding operator $\eta_k(\cdot)$ to keep k largest entries in s and sets all others to zero. The operation of IHT can be understood by (21).

$$s = \eta_k(s + \lambda \Theta^T (y - \Theta s)), \quad (21)$$

where λ denotes the step size used. The problem with the IHT algorithm is that if the step size is kept fixed, then algorithm may not converge. On the other hand, if the step size is adaptive, then algorithm becomes more complicated [43].

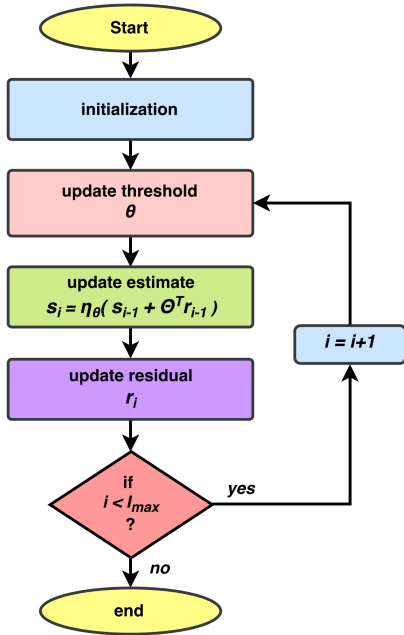

FIGURE 16. Algorithmic steps of AMP algorithm.

2) ITERATIVE SOFT THRESHOLDING ALGORITHM

This algorithm was introduced by Daubechies et al. [44], in 2004. In this algorithm, hard thresholding used in IHT algorithm is replaced by element wise soft thresholding operation $\eta_\theta(\cdot)$ with adaptive threshold θ , as given in (22).

$$\eta_\theta(s) = \text{sign}(s)[|s| - \theta]_+ \tag{22}$$

The value of θ is contracted gradually by multiplying with a scalar parameter $\mu \in (0, 1]$, i.e., $\theta_t = \mu\theta_{t-1}$. The solution is updated according to this thresholding operator as per (23), with initial conditions $r_0 = y, s_0 = 0$ and $C_0 = \Theta^T r_0$.

$$s_i = \eta_{\theta_{i-1}}(s_{i-1} + C_{i-1}) \tag{23}$$

Although, the IST has simpler data flow and is faster than ℓ_1 -minimization based approaches but its performance degrades as the signal sparseness decreases, i.e., as value of k increases.

3) APPROXIMATE MESSAGE PASSING ALGORITHM

The AMP algorithm is an improvement over IST, proposed by Donoho et al. [45], in 2009. AMP combines thresholding algorithms with message passing algorithms. The steps of AMP algorithm are shown in Fig.16. Similar to IST, AMP also employs component wise thresholding and same thresholding operator $\eta_\theta(\cdot)$ [46]. The main differences between the two which leads to improved convergence rate of AMP are:

- The threshold θ is updated using regularization parameter λ as well as past residual r_{i-1} , i.e., $\theta = \lambda \frac{1}{\sqrt{m}} \|r_{i-1}\|_2$.
- The current residual r_i is computed using current estimate s_i as well as past residual r_{i-1} , i.e., $r_i = y - \Theta_{\Lambda_i} s_i + br_{i-1}$, where, $b = \frac{1}{m} \|s_i\|_0$.

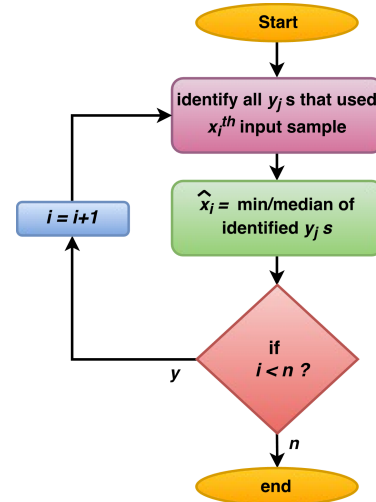

FIGURE 17. Algorithmic steps of count-min/median strategies used by algorithms under combinatorial approach.

The term br_{i-1} in calculation of residual is derived from the theory of belief propagation in graphical models. This helps in achieving a significant improvement in the sparsity-undersampling trade-off. AMP performs very well for deterministic and highly structured measurement matrices, like partial Fourier, toeplitz and circulant matrices, etc. The advantages like regular structure, fast convergence and low storage requirement makes them attractive choice for hardware implementation.

D. COMBINATORIAL APPROACH

Combinatorial algorithms were originally developed for solving sparse approximation problems in group testing to minimize the number of tests to be performed. The algorithms that come under this category are random Fourier sampling, heavy hitters on steroids (HHS), chaining pursuits and sparse sequential matching pursuit [47]. Reconstruction using these algorithms requires a specific measurement pattern. The measurement matrix φ is constructed using a set of discrete-valued functions, resulting in a specific pattern in φ , like exactly equal number of ones in each column but distributed randomly. This means that each measurement y_j is obtained by combining same number of samples of input signal.

The algorithms that come under this category make use of two strategies, namely, count-min and count-median. The steps for obtaining estimate of each sample of original signal using count-min/median approaches are described below and are shown in Fig.17. Let x_i be the i^{th} sample of the original input signal and \hat{x}_i be the estimate of x_i .

- Identify all the measurements y_j s that have used x_i^{th} sample of input signal in their calculation. This can be done with the help of measurement matrix.
- For count-min strategy, compute minimum value from the measurements identified in previous step. The minimum value so obtained is the estimate of the i^{th} sample of input

TABLE 3. Comparative summary of CS reconstruction approaches.

Approach	Complexity	Attributes	Pros	Cons
Convex	$\approx O(m^2n^3)$	<ul style="list-style-type: none"> – global optimization method – minimizes ℓ_1-norm to find solution 	<ul style="list-style-type: none"> – noise robustness – ability to superresolve 	<ul style="list-style-type: none"> – slower, Complex – difficult to implement for problems of larger size
Greedy	<ul style="list-style-type: none"> –serial version: $O(mnk)$ –parallel version: $O(mn.iter)$ 	<ul style="list-style-type: none"> –correlation based step-by-step iterative method 	<ul style="list-style-type: none"> –faster, low complexity and noise robustness –parallel versions has ability to discard wrong entries selected in previous iterations 	<ul style="list-style-type: none"> –prior knowledge of signal sparsity is required – requires more measurements than convex counterparts –convergence issues
Thresholding	$O(mn.iter)$	<ul style="list-style-type: none"> –uses some nonlinear thresholding criteria to select atoms 	<ul style="list-style-type: none"> –faster and low complexity – ability to add/discard multiple entries per iterations 	<ul style="list-style-type: none"> –Convergence issue with IST –better performance requires adaptive step size which increases complexity
Combinatorial	linear in n	<ul style="list-style-type: none"> –computes min or median of measurements identified as consisting of a particular I/P sample 	<ul style="list-style-type: none"> –faster and simpler 	<ul style="list-style-type: none"> –requires noiseless and specific pattern in measurements
Non-Convex	same as convex approaches	<ul style="list-style-type: none"> –minimizes ℓ_p-norm to find solution, where $0 < p < 1$ –global optimization method 	<ul style="list-style-type: none"> – recovers from fewer measurements than ℓ_1 counterpart – functions under weaker RIP – no. of measurements and error decreases with p 	<ul style="list-style-type: none"> –slower, complex – difficult to implement for problems of larger size
Bayesian	$O(nm^2)$	<ul style="list-style-type: none"> –poses recovery as Bayesian inference problem –applicable for signals belonging to some known probability distribution 	<ul style="list-style-type: none"> –faster and yields more sparser solution –estimates signal parameters without user intervention 	<ul style="list-style-type: none"> –results are prior dependent which is difficult to select –high computational cost

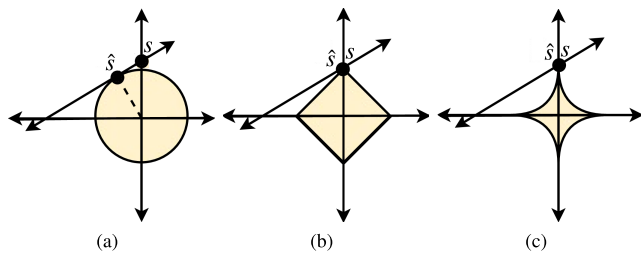

FIGURE 18. Example to illustrate sparse solution approximation using unit normed-balls in 2-D space: (a) ℓ_2 -ball, (b) ℓ_1 -ball, (c) $\ell_{1/2}$ -ball.

signal. In count-median strategy, instead of taking minimum value as estimate, median is computed and is used as estimate. Count-median is more general than count-min approach.

E. NON-CONVEX APPROACH

All CS reconstruction algorithms tries to find the sparsest possible solution from compressive measurements. An example explaining the ability of different norms to reconstruct the sparsest solution is shown with the help of unit normed-balls in Fig. 18. In 2-D space, the unit normed-balls can be obtained by connecting all the points for which the value of their respective norm is equal to 1. In this example, the solution s is assumed to be sparse with $k = 1$ and lies on the line intersecting the axes. To estimate the solution, when ℓ_2 -ball is expanded, it touches the line at a point which is not sparse, as shown in Fig.18(a). On the other hand, both ℓ_1

and $\ell_{1/2}$ -balls are able to hit the desired result, as shown in Fig.18(b) and Fig.18(c), respectively. As described earlier, the ℓ_1 -minimization, which is a convex optimization approach, searches for a solution with minimum ℓ_1 -norm. The non-convex approach replaces ℓ_1 -norm by ℓ_p -norm, where, $0 < p < 1$. This approach is able to recover the sparse solution from much fewer measurements compared to the convex approach. Another advantage of non-convex approach is that a weaker version of RIP condition is sufficient for perfect reconstruction. The algorithms that come under this category are focal underdetermined system solution (FOCUSS), iteratively re-weighted least squares (IRLS), etc. [48].

F. BAYESIAN APPROACH

Different from previous approaches which consider the input signal to be deterministic, Bayesian approach is applicable for the input signals which belongs to some known probability distribution. Hence, this approach seems to be of more practical interest. The distribution of coefficients of input signal can be two-state Gaussian-mixture model, i.i.d. Laplace prior model, etc. This approach pposes the reconstruction as Bayesian inference problem. The coefficients of input signal can be estimated using maximum likelihood estimate (MLE) or maximum a posteriori (MAP) estimate. The algorithms that are used to solve the Bayesian inference problem are belief propagation, sparse Bayesian learning using relevance vector machines, etc. These algorithms are

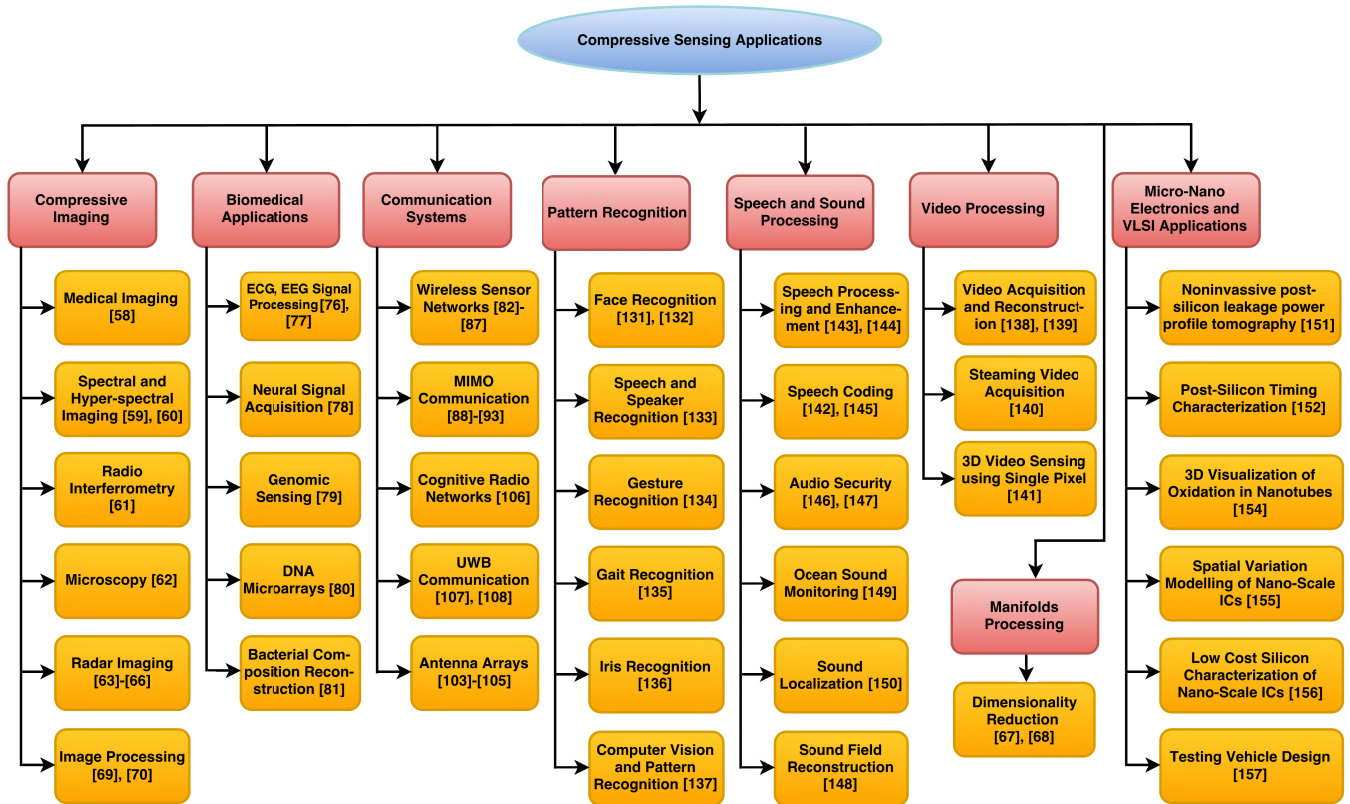

FIGURE 19. Major applications of CS.

not accompanied with the notion of reconstruction error. Another algorithm in this category is Bayesian compressive sensing (BCS) algorithm, which can compute the error term and accordingly makes adaptive decisions to find the solution [56].

A comparative summary of all CS reconstruction approaches is shown in Table 3, which may be helpful in selecting a reconstruction approach to meet system’s requirement. There is a rich literature on CS reconstruction algorithms, improving further upon the algorithms like OMP, AMP, weighted ℓ_1 and others [49]–[52].

IV. APPLICATIONS OF COMPRESSIVE SENSING

CS is being a growing field and a wide variety of applications has benefited from this sensing modality. Fig.19, shows a taxonomy listing major applications of CS. This section overviews the application areas where CS finds its applicability in current scenario. This may be helpful in identifying an application area to work on using CS.

A. COMPRESSIVE IMAGING

1) SINGLE-PIXEL CAMERA

For image acquisition using CS, several imaging architectures have been proposed in literature. One of the early and very famous architecture that demonstrates compressive imaging is the single-pixel camera proposed by Duarte *et al.* [57],

in 2008. This consists of a digital micro-mirror devices (DMD) array and the mirrors in this array can be turned on/off using a pseudorandom pattern generated by a pseudorandom sequence generator as shown in Fig.20. The operation upto this stage is equivalent to demodulation stage of RD, refer Fig.4. This multiplies light incident from scene with the pseudorandom pattern through DMD array. The reflected light from DMD array is then collected and focused onto a single photon detector and hence the name ‘single-pixel camera’. The job of this photodiode is equivalent to the integrator stage RD. The output of photodiode is then sampled by a low rate ADC to generate set of compressive measurements. These measurements can be easily stored or transmitted. At receiver end, the original scene can be reconstructed using CS reconstruction approach.

2) RADAR IMAGING SYSTEMS

The various types of radar imaging techniques where CS has been used are synthetic aperture radar (SAR), inverse synthetic aperture radar (ISAR), through the wall imaging radar (TWR) and ground penetrating radar imaging (GPR). In SAR imaging CS has been used to obtain high resolution map of spatial distribution of targets and terrain from much lesser transmitted/received data, simultaneously offering the advantages like resistance to countermeasures and interception, capturing much wider swaths while requiring lesser

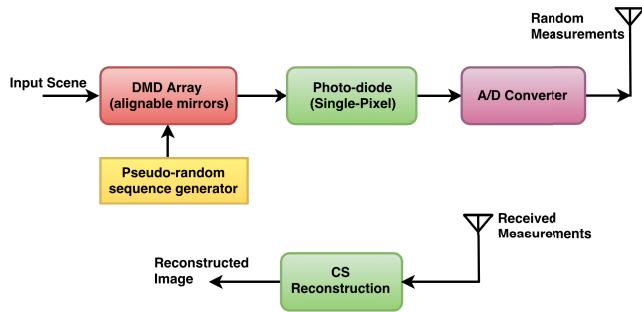

FIGURE 20. Block diagram of single-pixel camera.

on-board storage. In ISAR imaging, CS makes use of sparsity inherent in these images since the targets are concentrated at scattering centers. Here, CS offers advantages like robustness, high resolution from limited pulses. The problems of TWR imaging like prolonged and high amount of data acquisition required to achieve high resolution 2-D images, can be solved by using CS. In GPR imaging also, CS exploits the sparsity and recovers from fewer measurements.

Other imaging applications where CS has been applied are parallel imaging [71], microwave imaging [72], Sub-wavelength Imaging [73], underwater imaging [75], etc.

B. BIOMEDICAL APPLICATIONS

Major application of CS in biomedical field is biomedical imaging. Apart from that, CS has also been applied to the processing of other biological signals like electrocardiogram (ECG), electroencephalographic (EEG) and neural signals, etc., by exploiting the sparsity present in their features. The other biomedical applications are genomic sensing, DNA micro-arrays, study of proteins and bacterial composition reconstruction, etc.

C. COMMUNICATION SYSTEMS

The research community has accepted the wider applicability of CS in communication systems. In this section a review of widely used communication systems where CS is being applied is presented and also highlighted some important aspects of communication systems where CS plays an important role in making these systems efficient.

1) COMMUNICATION NETWORKS

- *Wireless Sensor Networks:* The efficient data gathering schemes based on CS has been proposed for wireless sensor networks (WSN) in exploiting raw data compressibility using opportunistic routing. These compressive data gathering schemes offers advantages like robustness, prolonged network lifetime, reduced energy consumption and simple routing scheme, etc. Apart from data gathering, the other aspects of WSNs like routing protocols, channel estimation, multiple access scheme, mitigating the data loss problem during transmission, clone identification, link quality information exchange,

data acquisition protocols for reactive WSN and target localization in WSNs has also been looked from the point of view of CS.

The various WSNs where CS has been applied are wireless body area networks [93], brain-machine interface [94] and wireless surface electromyography (EMG) [95] for tele-health monitoring; wireless structural health monitoring [96] and wireless cold chain monitoring [97]; surveillance [98]; lookup for roadside open wireless access points [100] and environment data gathering protocols for environment reconstruction application for in-depth understanding of physical world [99]. In context to IoT, CS has been applied to address the issues like reduction in energy consumption in handling big data [101], multiuser-detection [102], etc.

- *Antenna Arrays:* CS has been used to reduce the number of elements and background interference in antenna array to achieve desired beamforming. CS has also been used to optimize the design of tripole arrays and to determine target range and azimuth using random frequency diverse antenna array.
- *Cognitive Radio (CR) Networks:* CS finds its applicability in CR communication by exploiting the sparsity in spectrum occupancy due to under-utilization of spectrum. CS based AICs have been proposed for efficient wideband spectrum sensing in CRs. The problem of primary user detection in CRs has also been addressed using total variation minimization, modified OMP algorithm, Bayesian framework, blind spectrum detection, cooperative sensing, distributed sensing, adaptive sensing, etc.
- *UWB Communication:* UWB communication basically makes use of CS architecture called RMPI, for acquisition of UWB signals. The reconstruction of original signal can be done by exploiting its spatial and temporal information. The other issues like, impulse radio detection, echo detection, channel estimation, high precision ranging and non-coherent UWB systems, etc. has also been addressed using CS.

2) VARIOUS ASPECTS OF COMMUNICATION SYSTEMS

- *Direction of Arrival (DoA) Estimation:* Method for compressive beamforming using random projections of the sensor data for DoA estimation has been proposed. CS also has been used to solve problems in beamforming like grid-mismatch, reducing the number of sensors, DoA estimation for non-circular sources and also for the arrays with multiple co-prime frequencies [109], [110].
- *Information Security:* Information security is an important aspect of communication system. CS addresses this issue by using measurement matrix as a secret key and the compressive measurements as an encrypted message. This is an auto-encryption feature of CS, which makes CS as a technique for simultaneous acquisition, compression and encryption of signals. This security

feature of CS has been used in image processing for image tempering localization, image copy detection, secure image coding, secure watermarking, multi-image encryption, simultaneous compression-encryption and fusion, visual cryptography for multichannel transmission, double encryption, remote sensing image compression, encryption and optical encryption using computational ghost imaging, etc. The audio signal processing also makes use of security feature of CS in audio tempering identification. Similarly, addressing security aspect in video processing, CS has been used for video coding, video forgery detection, etc. The other application utilizing this feature are differential encryption providing privacy guarantee against adversaries with arbitrary prior knowledge, multi-signal encryption, ECG encryption, secure compressive wire-tap channel, etc. [111]–[120].

- *Network Traffic Monitoring*: Compressing sensing has been used to monitor network traffic with minimum number of measurements, while maintaining acceptable estimation accuracy. CS with expander graphs has been used to maintain a compressed summary of average packet arrival rate and instantaneous packet count using small number of counters at a router in communication network. It has also been used to reduce the number of training symbols in a communication packet and in joint source-channel network coding [121]–[123].
- *Superresolution*: Robust superresolution has been achieved using CS. Prominent work on this aspect includes spectral estimation in spaceborn tomographic SAR, single image superresolution, geometric separation and multi-dimensional superresolution using primal ℓ_1 -minimization, etc. [127]–[129].
- *Blind Source Separation (BSS)*: CS for BSS addresses the separation of signal sources from the mixed music/speech signal using two-stage cluster-then- ℓ_1 -optimization approach and using non-negative matrix factorization, etc. [130].

The other aspects of communication systems addressed using CS are feedback reduction for joint user identification and SNR estimation, dynamic spectrum access, indoor white-space exploration, random access in machine type communications over frequency-selective fading channels, multichannel sampling, channel estimation in wireless OFDM systems, etc. [124]–[126].

D. PATTERN RECOGNITION

An expression invariant face recognition technique has been proposed based on CS. This exploits the fact that expression changes are sparse in consideration to whole image. Another face recognition technique based on sparsity preserving projections and ℓ_1 -minimization has been proposed. These projections have been shown to be invariant to rotations, rescalings and translations of the data and also contain natural discriminating information even in absence of class labels.

A robust speech recognition technique from missing data has been proposed using CS. This exploits the fact that missing features are sparse in a wider time window. Another techniques for robust speaker recognition have also been proposed in literature. In gesture recognition, a technique based on ℓ_1 -minimization has been proposed, achieving almost perfect user-dependent recognition and mixed-user recognition. The applicability of CS for gait recognition has also been demonstrated using gait energy image as the feature extraction process. Similar applications are iris recognition using sparse representation, dictionary based computer vision and pattern recognition, etc.

E. VIDEO PROCESSING

CS has enabled a real-time 3D video acquisition using single pixel camera. Among CS based video processing techniques, few are: distributed compressed video sensing in which sampling of video frames is done independently while reconstruction is done jointly, adaptive video sensing utilizing block based CS reconstruction and streaming CS for high speed periodic videos based on coded projections of dynamic events, etc.

F. SPEECH AND SOUND PROCESSING

The applicability of CS for speech and sound processing has been demonstrated in literature. Some of the ways that have been used for compressive speech processing are: sparse linear predictions and sparse pattern retrieval in residual domain, deriving and capturing compressively the sparse feature vector from mechanism of speech production which is different for voiced and nonvoiced speeches, speech enhancement based on BCS, and CS for speech coding exploiting the sparsity in phonological features, etc. Similarly, CS for audio signals includes aspects like security and relative impulse response estimation, etc. CS has also been applied to sound field reproduction with application to acoustic and ultrasound treatment, anthropogenic ocean sound monitoring and source localization, etc.

G. MANIFOLDS PROCESSING

Manifold models provide a strong framework for representing structure underlying the high dimensional data with the help of small number of parameters. CS has been applied to manifold-modeled data for achieving dimensionality reduction. The key information regarding manifold-modeled signal can be preserved using random linear projections. Exploiting the dependencies among the different dimensions of high dimensional data, a CS based joint manifold framework has also been proposed.

H. MICRO AND NANO-ELECTRONICS AND VLSI APPLICATIONS

The applications in these areas that have been explored using CS are: noninvasive post-silicon leakage power profile tomography by exploiting the sparsity due to correlations in tomogram, post-silicon timing characterization by

exploring the sparsity of timing variations in wavelet domain, fine grained processor performance monitoring by exploiting structured sparsity of processor's micro-architectural information [153], 3D Visualization of the iron oxidation state in FeO/Fe₃O₄ core-shell nanocubes, modeling the spatial variations of nanoscale ICs by exploring sparsity due to correlated representation of spatial variations in frequency domain, quantum state tomography [74], low-cost silicon characterization of nanoscale integrated circuits, CS based testing vehicle for 3D TSV pre-bond and post-bond testing data, online estimation of system's power distribution factors [158] and low complexity method for long term field measurement of insulator leakage current [159], etc.

V. CHALLENGES AND FUTURE SCOPE

CS has gained a wider acceptance in a shorter time span, as a sampling technique for sampling the signals at their information rate. CS takes the advantage of sparsity or compressibility of the underlying signal to simultaneously sample and compress the signal. CS has a strong mathematical foundation also. But, the increasing popularity and acceptability of CS faces some challenges. We are highlighting some of the challenges, which also leads to some working directions in the field.

- There is need for a simple and efficient, universal CS acquisition strategy which is applicable to majority of the signals and also leads to faster acquisition.
- Similarly, a universal CS reconstruction algorithm, which is faster, robust, less complex and gives guaranteed convergence is needed.
- Searching a suitable basis, in which signal to be acquired has sparsest possible representation, is itself a tough task. If one can identify the basis in which signal has the sparsest possible representation, then it will help in faithful reconstruction from further reduced CS measurements. So, a system needs to be developed, which can determine the sparsifying basis of signal.
- Development of rigorous performance bounds for the issues like minimum number of measurements and reconstruction iterations required for perfect reconstruction, guaranteed convergence, stable recovery, etc., are also workable areas in this field.
- Also, research is being going on structured CS. The advantages of this approach are faster acquisition, lower complexity, easier to implement, etc. But the drawback is that the faithful reconstruction requires more number of measurements. Also, it is difficult to have structured measurement matrices which obey RIP condition. Some proposals of RIPless CS have also been seen in literature, which can be worked further to take advantages of structured measurements in CS.

The theoretical concept of CS described earlier in this paper is the classical CS. There can be application specific challenges, that needs to be tackled by modifying the classical version. Some of the highlights in this regard are presented

below:

- In case of multidimensional signals, design of an acquisition system and identification of a sparsifying basis is very difficult. Kronecker product matrices has been incorporated in CS to solve these problems. Other methods can be tried in this situation.
- The type of the signals in which non-zero coefficients occur in clusters, are termed as block sparse signals. The challenges encountered in applying CS to this type of the signals are: block-sparsity and block coherence considerations for block based acquisition, modifications in reconstruction algorithms to account for block sparsity and model mismatches, etc.
- In some cases, CS measurements are gathered from multiple sources, which are related in some sense. In this situation, Bayesian framework helps in reducing the number of measurements by a criterion to stop acquisition when the sufficient number of measurements have been taken. This also gives a way for robust data fusion from multiple sources. Another approach is to use distributed coding algorithms, by exploring the joint sparsity in multiple signals. Applicability of other approaches can also be researched for this.
- Inference problems in signal processing like, detection, classification, estimation and filtering, do not require full signal reconstruction. Solving the inference problems from CS compressed measurements only, without reconstructing the signal is a bigger challenge. This aids in reducing measurement cost further and allows to get rid of complex reconstruction process.
- Considering the importance of quantizing the CS measurements in lieu of finite precision, a distortion is introduced in CS measurements. Therefore, reconstruction algorithms needs to be modified to account for quantization error of CS measurements. Also, the research is progressing towards recovering the CS measurements which are quantized using a single bit only. This 1-bit version of CS offers advantages like simple acquisition and robustness to gross non-linearities. This is also a promising direction to explore further.
- Other challenges are, reconstruction from binary CS measurements, incorporating prior knowledge to enhance reconstruction performance, addressing architectural issues for efficient hardware implementation, efficient software implementations, measurement techniques to further reduce minimum number of measurements, etc.

VI. CONCLUSION

Introduction of CS has revolutionized many areas in signal processing, where there were limited scopes. Some of the major contributions are faster MRI, high quality image and video acquisition using single pixel camera, acquisition of UWB signals while drastically reducing the power consumption, etc. This paper has presented a systematical review of

CS. Considering its rigorous mathematics, which is sometimes a barrier for many young researchers, we presented a simplified introduction of CS. For an easy transition from theory with practicality, a summary of CS acquisition techniques and reconstruction approaches has also been presented. The CS acquisition approach may vary from signal to signal. Similarly, the reconstruction approach to be used is also highly signal dependent, which may further needs to be modified to suit a particular situation. It will be highly beneficial to have a universal CS acquisition and reconstruction strategy. A review of major application areas where CS is currently being utilized has also been presented.

REFERENCES

- [1] E. J. Candès, J. Romberg, and T. Tao, "Robust uncertainty principles: Exact signal reconstruction from highly incomplete frequency information," *IEEE Trans. Inf. Theory*, vol. 52, no. 2, pp. 489–509, Feb. 2006.
- [2] D. L. Donoho, "Compressed sensing," *IEEE Trans. Inf. Theory*, vol. 52, no. 4, pp. 1289–1306, Apr. 2006.
- [3] E. J. Candès and T. Tao, "Near-optimal signal recovery from random projections: Universal encoding strategies?" *IEEE Trans. Inf. Theory*, vol. 52, no. 12, pp. 5406–5425, Dec. 2006.
- [4] R. G. Baraniuk, "Compressive sensing [lecture notes]," *IEEE Signal Process. Mag.*, vol. 24, no. 4, pp. 118–121, Jul. 2007.
- [5] E. J. Candès and M. B. Wakin, "An introduction to compressive sampling," *IEEE Signal Process. Mag.*, vol. 25, no. 2, pp. 21–30, Mar. 2008.
- [6] E. J. Candès, "Compressive sampling," in *Proc. Int. Congr. Math.*, Madrid, Spain, Aug. 2006, pp. 1433–1452.
- [7] E. Candès and J. Romberg, "Sparsity and incoherence in compressive sampling," *Inverse Problems*, vol. 23, no. 3, pp. 969–985, 2007.
- [8] R. Baraniuk. (Apr. 2, 2011). *An Introduction to Compressive Sensing*. OpenStax-CNX. [Online]. Available: <http://legacy.cnx.org/content/col11331/1.5/>
- [9] E. J. Candès, "The restricted isometry property and its implications for compressed sensing," *Comptes Rendus Math.*, vol. 346, nos. 9–10, pp. 589–592, 2008.
- [10] D. L. Donoho, "For most large underdetermined systems of linear equations the minimal ℓ^1 -norm solution is also the sparsest solution," *Commun. Pure Appl. Math.*, vol. 59, no. 6, pp. 797–829, Jun. 2006.
- [11] E. J. Candès and T. Tao, "Decoding by linear programming," *IEEE Trans. Inf. Theory*, vol. 51, no. 12, pp. 4203–4215, Dec. 2005.
- [12] S. Mallat, *A Wavelet Tour of Signal Processing: The Sparse Way*, 3rd ed. Burlington, MA, USA: Academic, 2009.
- [13] J. Kovacevic and A. Chebira, "Life beyond bases: The advent of frames (Part I)," *IEEE Signal Process. Mag.*, vol. 24, no. 4, pp. 86–104, Jul. 2007.
- [14] J. Kovacevic and A. Chebira, "Life beyond bases: The advent of frames (Part II)," *IEEE Signal Process. Mag.*, vol. 24, no. 5, pp. 115–125, Sep. 2007.
- [15] R. Rubinfeld, A. M. Bruckstein, and M. Elad, "Dictionaries for sparse representation modeling," *Proc. IEEE*, vol. 98, no. 6, pp. 1045–1057, Jun. 2010.
- [16] R. Gribonval and M. Nielsen, "Sparse representations in unions of bases," *IEEE Trans. Inf. Theory*, vol. 49, no. 12, pp. 3320–3325, Dec. 2003.
- [17] G. H. Golub and C. F. Van Loan, "Matrix analysis," in *Matrix Computations*, 4th ed. Baltimore, MD, USA: The Johns Hopkins Univ. Press, 2013, ch. 2, pp. 68–73.
- [18] J. N. Laska, S. Kirolos, M. F. Duarte, T. S. Ragheb, R. G. Baraniuk, and Y. Massoud, "Theory and implementation of an analog-to-information converter using random demodulation," in *Proc. IEEE Int. Symp. Circuits Syst.*, New Orleans, LA, USA, May 2007, pp. 1959–1962.
- [19] J. A. Tropp, J. N. Laska, M. F. Duarte, J. K. Romberg, and R. G. Baraniuk, "Beyond Nyquist: Efficient sampling of sparse banded signals," *IEEE Trans. Inf. Theory*, vol. 56, no. 1, pp. 520–544, Jan. 2010.
- [20] J. Yoo, S. Becker, M. Monge, M. Loh, E. J. Candès, and A. Emami-Neyestanak, "Design and implementation of a fully integrated compressed-sensing signal acquisition system," in *Proc. IEEE Int. Conf. Acoust., Speech Signal Process. (ICASSP)*, Kyoto, Japan, Mar. 2012, pp. 5325–5328.
- [21] M. Mishali and Y. C. Eldar, "From theory to practice: Sub-Nyquist sampling of sparse wideband analog signals," *IEEE J. Sel. Topics Signal Process.*, vol. 4, no. 2, pp. 375–391, Apr. 2010.
- [22] J. A. Tropp, M. B. Wakin, M. F. Duarte, D. Baron, and R. G. Baraniuk, "Random filters for compressive sampling and reconstruction," in *Proc. IEEE Int. Conf. Acoust., Speech Signal Process.*, Toulouse, France, May 2006, p. 3.
- [23] J. K. Romberg, "Compressive sensing by random convolution," *SIAM J. Imag. Sci.*, vol. 2, no. 4, pp. 1098–1128, Dec. 2009.
- [24] J. P. Slavinsky, J. N. Laska, M. A. Davenport, and R. G. Baraniuk, "The compressive multiplexer for multi-channel compressive sensing," in *Proc. IEEE Int. Conf. Acoust., Speech Signal Process. (ICASSP)*, Prague, Czech Republic, May 2011, pp. 3980–3983.
- [25] Y. Zhao, Y. H. Hu, and H. Wang, "Enhanced random equivalent sampling based on compressed sensing," *IEEE Trans. Instrum. Meas.*, vol. 61, no. 3, pp. 579–586, Mar. 2012.
- [26] Y. Zhao, Y. H. Hu, and J. Liu, "Random triggering-based sub-Nyquist sampling system for sparse multiband signal," *IEEE Trans. Instrum. Meas.*, vol. 66, no. 7, pp. 1789–1797, Jul. 2017.
- [27] T. Haque, R. T. Yazicigil, K. J.-L. Pan, J. Wright, and P. R. Kinget, "Theory and design of a quadrature analog-to-information converter for energy-efficient wideband spectrum sensing," *IEEE Trans. Circuits Syst. I, Reg. Papers*, vol. 62, no. 2, pp. 527–535, Feb. 2015.
- [28] S. S. Chen, D. L. Donoho, and M. A. Saunders, "Atomic decomposition by basis pursuit," *SIAM J. Sci. Comput.*, vol. 20, no. 1, pp. 33–61, 1999.
- [29] E. J. Candès and T. Tao, "The Dantzig selector: Statistical estimation when p is much larger than n ," *Ann. Statist.*, vol. 35, no. 6, pp. 2313–2351, 2007.
- [30] R. Tibshirani, "Regression shrinkage and selection via the lasso," *J. Roy. Statist. Soc. B, Methodol.*, vol. 58, no. 1, pp. 267–288, 1996.
- [31] L. I. Rudin, S. Osher, and E. Fatemi, "Nonlinear total variation based noise removal algorithms," *Phys. D, Nonlinear Phenomena*, vol. 60, nos. 1–4, pp. 259–268, 1992.
- [32] E. Hale, W. Yin, and Y. Zhang, "A fixed-point continuation method for ℓ_1 -regularized minimization with applications to compressed sensing," CAAM Tech. Rep. TR07-07, 2007, pp. 1–45.
- [33] M. A. T. Figueiredo, R. D. Nowak, and S. J. Wright, "Gradient projection for sparse reconstruction: Application to compressed sensing and other inverse problems," *IEEE J. Sel. Topics Signal Process.*, vol. 1, no. 4, pp. 586–597, Dec. 2007.
- [34] S. Osher, M. Burger, D. Goldfarb, J. Xu, and W. Yin, "An iterative regularization method for total variation-based image restoration," *Multiscale Model. Simul.*, vol. 4, no. 2, pp. 460–489, 2005.
- [35] J.-F. Cai, S. Osher, and Z. Shen, "Linearized Bregman iterations for compressed sensing," *Math. Comput.*, vol. 78, no. 267, pp. 1515–1536, 2009.
- [36] T. Goldstein and S. Osher, "The split Bregman method for L1-regularized problems," *SIAM J. Imag. Sci.*, vol. 2, no. 2, pp. 323–343, 2009.
- [37] S. G. Mallat and Z. Zhang, "Matching pursuits with time-frequency dictionaries," *IEEE Trans. Signal Process.*, vol. 41, no. 12, pp. 3397–3415, Dec. 1993.
- [38] Y. C. Pati, R. Rezaifar, and P. S. Krishnaprasad, "Orthogonal matching pursuit: Recursive function approximation with applications to wavelet decomposition," in *Proc. 27th Asilomar Conf. Signals, Syst. Comput.*, vol. 1. Pacific Grove, CA, USA, 1993, pp. 40–44.
- [39] T. Blumensath and M. E. Davies, "Gradient pursuits," *IEEE Trans. Signal Process.*, vol. 56, no. 6, pp. 2370–2382, Jun. 2008.
- [40] D. Needell and J. A. Tropp, "CoSaMP: Iterative signal recovery from incomplete and inaccurate samples," *Appl. Comput. Harmon. Anal.*, vol. 26, no. 3, pp. 301–321, May 2009.
- [41] W. Dai and O. Milenkovic, "Subspace pursuit for compressive sensing signal reconstruction," *IEEE Trans. Inf. Theory*, vol. 55, no. 5, pp. 2230–2249, May 2009.
- [42] T. Blumensath and M. E. Davies, "Iterative hard thresholding for compressed sensing," *Appl. Comput. Harmon. Anal.*, vol. 27, no. 3, pp. 265–274, Nov. 2009.
- [43] T. Blumensath and M. E. Davies, "Normalized iterative hard thresholding: Guaranteed stability and performance," *IEEE J. Sel. Topics Signal Process.*, vol. 4, no. 2, pp. 298–309, Apr. 2010.
- [44] I. Daubechies, M. Deffrise, and C. De Mol, "An iterative thresholding algorithm for linear inverse problems with a sparsity constraint," *Commun. Pure Appl. Math.*, vol. 57, no. 11, pp. 1413–1457, Nov. 2004.

- [45] D. L. Donoho, A. Maleki, and A. Montanari, "Message-passing algorithms for compressed sensing," *Proc. Nat. Acad. Sci. USA*, vol. 106, no. 45, pp. 18914–18919, Sep. 2009.
- [46] A. Montanari. (Mar. 2011). "Graphical models concepts in compressed sensing." [Online]. Available: <https://arxiv.org/abs/1011.4328>
- [47] G. Cormode, "Sketch techniques for approximate query processing," in *Foundations and Trends in Databases*. Norwell, MA, USA: Now Publishers, 2011.
- [48] R. Chartrand and V. Staneva, "Restricted isometry properties and non-convex compressive sensing," *Inverse Problems*, vol. 24, no. 3, p. 35020, May 2008.
- [49] D. Needell and R. Vershynin, "Signal recovery from incomplete and inaccurate measurements via regularized orthogonal matching pursuit," *IEEE J. Sel. Topics Signal Process.*, vol. 4, no. 2, pp. 310–316, Apr. 2010.
- [50] J. Wang, S. Kwon, and B. Shim, "Generalized orthogonal matching pursuit," *IEEE Trans. Signal Process.*, vol. 60, no. 12, pp. 6202–6216, Dec. 2012.
- [51] S. Rangan, "Generalized approximate message passing for estimation with random linear mixing," in *Proc. IEEE Int. Symp. Inf. Theory*, St. Petersburg, Russia, Jul./Aug. 2011, pp. 2168–2172.
- [52] M. A. Khajehnejad, W. Xu, A. S. Avestimehr, and B. Hassibi, "Weighted ℓ_1 minimization for sparse recovery with prior information," in *Proc. IEEE Int. Symp. Inf. Theory*, Seoul, South Korea, Jun./Jul. 2009, pp. 483–487.
- [53] W. Yin, S. Morgan, J. Yang, and Y. Zhang, "Practical compressive sensing with Toeplitz and circulant matrices," *Proc. SPIE*, vol. 7744, p. 77440K, Apr. 2010.
- [54] T. T. Do, L. Gan, N. H. Nguyen, and T. D. Tran, "Fast and efficient compressive sensing using structurally random matrices," *IEEE Trans. Signal Process.*, vol. 60, no. 1, pp. 139–154, Jan. 2012.
- [55] M. F. Duarte and Y. C. Eldar, "Structured compressed sensing: From theory to applications," *IEEE Trans. Signal Process.*, vol. 59, no. 9, pp. 4053–4085, Sep. 2011.
- [56] S. Ji and L. Carin, "Bayesian compressive sensing and projection optimization," in *Proc. 24th Int. Conf. Mach. Learn. (ICML)*, 2007, pp. 377–384.
- [57] M. F. Duarte et al., "Single-pixel imaging via compressive sampling," *IEEE Signal Process. Mag.*, vol. 25, no. 2, pp. 83–91, Mar. 2008.
- [58] R. Otazo, E. J. Candès, and D. K. Sodickson, "Low-rank plus sparse matrix decomposition for accelerated dynamic MRI with separation of background and dynamic components," *Magn. Reson. Med.*, vol. 73, no. 3, pp. 1125–1136, 2014.
- [59] P. Cao and E. X. Wu, "Accelerating phase-encoded proton MR spectroscopic imaging by compressed sensing," *J. Magn. Reson. Imag.*, vol. 41, no. 2, pp. 487–495, 2014.
- [60] W. Huang, L. Xiao, H. Liu, and Z. Wei, "Hyperspectral imagery super-resolution by compressive sensing inspired dictionary learning and spatial-spectral regularization," *Sensors*, vol. 15, no. 1, pp. 2041–2058, 2015.
- [61] S. V. Kartik, R. E. Carrillo, J.-P. Thiran, and Y. Wiaux, "A Fourier dimensionality reduction model for big data interferometric imaging," *Monthly Notices Roy. Astron. Soc.*, vol. 468, no. 2, pp. 2382–2400, 2017.
- [62] T. Arildsen, C. S. Oxvig, P. S. Pedersen, J. Østergaard, and T. Larsen, "Reconstruction algorithms in undersampled AFM imaging," *IEEE J. Sel. Topics Signal Process.*, vol. 10, no. 1, pp. 31–46, Feb. 2016.
- [63] V. M. Patel, G. R. Easley, D. M. Healy, Jr., and R. Chellappa, "Compressed synthetic aperture radar," *IEEE J. Sel. Topics Signal Process.*, vol. 4, no. 2, pp. 244–254, Apr. 2010.
- [64] L. Zhang et al., "Resolution enhancement for inversed synthetic aperture radar imaging under low SNR via improved compressive sensing," *IEEE Trans. Geosci. Remote Sens.*, vol. 48, no. 10, pp. 3824–3838, Oct. 2010.
- [65] Q. Huang, L. Qu, B. Wu, and G. Fang, "UWB through-wall imaging based on compressive sensing," *IEEE Trans. Geosci. Remote Sens.*, vol. 48, no. 3, pp. 1408–1415, Mar. 2010.
- [66] A. C. Gurbuz, J. H. McClellan, and W. R. Scott, Jr., "Compressive sensing for subsurface imaging using ground penetrating radar," *Signal Process.*, vol. 89, no. 10, pp. 1959–1972, 2009.
- [67] M. A. Davenport, C. Hegde, M. F. Duarte, and R. G. Baraniuk, "Joint manifolds for data fusion," *IEEE Trans. Image Process.*, vol. 19, no. 10, pp. 2580–2594, Oct. 2010.
- [68] R. G. Baraniuk and M. B. Wakin, "Random projections of smooth manifolds," *Found. Comput. Math.*, vol. 9, no. 1, pp. 51–77, 2009.
- [69] C. A. Metzler, A. Maleki, and R. G. Baraniuk. (Apr. 2016). "From denoising to compressed sensing." [Online]. Available: <https://arxiv.org/abs/1406.4175>
- [70] S. Li and B. Yang, "A new pan-sharpening method using a compressed sensing technique," *IEEE Trans. Geosci. Remote Sens.*, vol. 49, no. 2, pp. 738–746, Feb. 2011.
- [71] X. Peng et al., "Incorporating reference in parallel imaging and compressed sensing," *Magn. Reson. Med.*, vol. 73, no. 4, pp. 1490–1504, 2014.
- [72] M. T. Bevacqua, L. Crocco, L. D. Donato, and T. Isernia, "Microwave imaging of nonweak targets via compressive sensing and virtual experiments," *IEEE Antennas Wireless Propag. Lett.*, vol. 14, pp. 1035–1038, 2015.
- [73] A. Szameit et al., "Sparsity-based single-shot subwavelength coherent diffractive imaging," *Nature Mater.*, vol. 11, no. 5, pp. 455–459, 2012.
- [74] D. Gross, Y.-K. Liu, S. T. Flammia, S. Becker, and J. Eisert, "Quantum state tomography via compressed sensing," *Phys. Rev. Lett.*, vol. 105, no. 15, p. 150401, 2010.
- [75] B. Ouyang et al., "Underwater laser serial imaging using compressive sensing and digital mirror device," *Proc. SPIE*, vol. 8037, p. 803707, Jun. 2011.
- [76] M. Abo-Zahhad, "Compression of ECG signal based on compressive sensing and the extraction of significant features," *Int. J. Commun., Netw. Syst. Sci.*, vol. 8, no. 5, pp. 97–117, 2015.
- [77] K.-K. Poh and P. Marziliano, "Compressive sampling of EEG signals with finite rate of innovation," *EURASIP J. Adv. Signal Process.*, vol. 2010, p. 183105, Dec. 2010.
- [78] X. Liu, H. Zhu, M. Zhang, A. G. Richardson, T. H. Lucas, and J. Van der Spiegel, "Design of a low-noise, high power efficiency neural recording front-end with an integrated real-time compressed sensing unit," in *Proc. IEEE Int. Symp. Circuits Syst. (ISCAS)*, Lisbon, Portugal, 2015, pp. 2996–2999.
- [79] W. Tang, H. Cao, J. Duan, and Y. P. Wang, "A compressed sensing based approach for subtyping of leukemia from gene expression data," *J. Bioinform. Comput. Biol.*, vol. 9, no. 5, pp. 631–645, 2011.
- [80] W. Dai, M. A. Sheikh, O. Milenkovic, and R. G. Baraniuk, "Compressive sensing DNA microarrays," *EURASIP J. Bioinform. Syst. Biol.*, vol. 2009, p. 162824, Dec. 2008.
- [81] A. Amir and O. Zuk, "Bacterial community reconstruction using compressed sensing," *J. Comput. Biol.*, vol. 18, no. 11, pp. 1723–1741, 2011.
- [82] X.-Y. Liu et al., "CDC: Compressive data collection for wireless sensor networks," *IEEE Trans. Parallel Distrib. Syst.*, vol. 26, no. 8, pp. 2188–2197, Aug. 2015.
- [83] K. Xin, P. Cheng, and J. Chen, "Multi-target localization in wireless sensor networks: A compressive sampling-based approach," *Wireless Commun. Mobile Comput.*, vol. 15, no. 5, pp. 801–811, 2013.
- [84] A. Aziz, "Efficient compressive sensing based technique for routing in wireless sensor networks," *INFOCOMP J. Comput. Sci.*, vol. 12, no. 1, pp. 1–9, 2013.
- [85] J. P. Hong, W. Choi, and B. D. Rao, "Sparsity controlled random multiple access with compressed sensing," *IEEE Trans. Wireless Commun.*, vol. 14, no. 2, pp. 998–1010, Feb. 2015.
- [86] H. Okada, S. Suzaki, T. Kato, K. Kobayashi, and M. Katayama, "Link quality information sharing by compressed sensing and compressed transmission for arbitrary topology wireless mesh networks," *IEICE Trans. Commun.*, vol. 100, no. 3, pp. 456–464, 2017.
- [87] F. A. Aderohunmu, D. Brunelli, J. D. Deng, and M. K. Purvis, "A data acquisition protocol for a reactive wireless sensor network monitoring application," *Sensors*, vol. 15, no. 5, pp. 10221–10254, 2015.
- [88] W. U. Bajwa, J. Haupt, A. M. Sayeed, and R. Nowak, "Compressed channel sensing: A new approach to estimating sparse multipath channels," *Proc. IEEE*, vol. 98, no. 6, pp. 1058–1076, Jun. 2010.
- [89] M. E. Eltayeb, T. Y. Al-Naffouri, and H. R. Bahrami, "Compressive sensing for feedback reduction in MIMO broadcast channels," *IEEE Trans. Commun.*, vol. 62, no. 9, pp. 3209–3222, Sep. 2014.
- [90] J.-C. Shen, J. Zhang, E. Alsusa, and K. B. Letaief, "Compressed CSI acquisition in FDD massive MIMO: How much training is needed?" *IEEE Trans. Wireless Commun.*, vol. 15, no. 6, pp. 4145–4156, Jun. 2016.
- [91] R. W. Heath, Jr., N. González-Prelcic, S. Rangan, W. Roh, and A. M. Sayeed, "An overview of signal processing techniques for millimeter wave MIMO systems," *IEEE J. Sel. Topics Signal Process.*, vol. 10, no. 3, pp. 436–453, Apr. 2016.

- [92] N. Garcia, H. Wymeersch, E. G. Larsson, A. M. Haimovich, and M. Coulon, "Direct localization for massive MIMO," *IEEE Trans. Signal Process.*, vol. 65, no. 10, pp. 2475–2487, May 2017.
- [93] A. Wang, F. Lin, Z. Jin, and W. Xu, "A configurable energy-efficient compressed sensing architecture with its application on body sensor networks," *IEEE Trans. Ind. Informat.*, vol. 12, no. 1, pp. 15–27, Feb. 2016.
- [94] X. Liu, M. Zhang, B. Subei, A. G. Richardson, T. H. Lucas, and J. V. D. Spiegel, "The PennBMBI: Design of a general purpose wireless brain-machine-brain interface system," *IEEE Trans. Biomed. Circuits Syst.*, vol. 9, no. 2, pp. 248–258, Apr. 2015.
- [95] M. Balouchestani and S. Krishnan, "Robust compressive sensing algorithm for wireless surface electromyography applications," *Biomed. Signal Process. Control*, vol. 20, pp. 100–106, Jul. 2015.
- [96] Z. Zou, Y. Bao, H. Li, B. F. Spencer, and J. Ou, "Embedding compressive sensing-based data loss recovery algorithm into wireless smart sensors for structural health monitoring," *IEEE Sensors J.*, vol. 15, no. 2, pp. 797–808, Feb. 2015.
- [97] X. Xiao, Q. He, Z. Fu, M. Xu, and X. Zhang, "Applying CS and WSN methods for improving efficiency of frozen and chilled aquatic products monitoring system in cold chain logistics," *Food Control*, vol. 60, pp. 656–666, Feb. 2016.
- [98] B. Kang and W.-P. Zhu, "Robust moving object detection using compressed sensing," *IET Image Process.*, vol. 9, no. 9, pp. 811–819, Sep. 2015.
- [99] L. Kong et al., "Resource-efficient data gathering in sensor networks for environment reconstruction," *Comput. J.*, vol. 58, no. 6, pp. 1330–1343, 2014.
- [100] D. Wu, D. I. Arkhipov, Y. Zhang, C. H. Liu, and A. C. Regan, "Online war-driving by compressive sensing," *IEEE Trans. Mobile Comput.*, vol. 14, no. 11, pp. 2349–2362, Nov. 2015.
- [101] L. Kong, D. Zhang, Z. He, Q. Xiang, J. Wan, and M. Tao, "Embracing big data with compressive sensing: A green approach in industrial wireless networks," *IEEE Commun. Mag.*, vol. 54, no. 10, pp. 53–59, Oct. 2016.
- [102] J. Liu, H.-Y. Cheng, C.-C. Liao, and A.-Y. A. Wu, "Scalable compressive sensing-based multi-user detection scheme for Internet-of-Things applications," in *Proc. IEEE Workshop Signal Process. Syst. (SIPS)*, Hangzhou, China, Oct. 2015, pp. 1–6.
- [103] G. F. Edelmann and C. F. Gaumont, "Beamforming using compressive sensing," *J. Acoust. Soc. Amer.*, vol. 130, no. 4, pp. EL232–EL237, 2011.
- [104] M. Hawes, W. Liu, and L. Mihaylova, "Compressive sensing based design of sparse tripole arrays," *Sensors*, vol. 15, no. 12, pp. 31056–31068, 2015.
- [105] Y. Liu, H. Ruan, L. Wang, and A. Nehorai, "The random frequency diverse array: A new antenna structure for uncoupled direction-range indication in active sensing," *IEEE J. Sel. Topics Signal Process.*, vol. 11, no. 2, pp. 295–308, Mar. 2017.
- [106] S. K. Sharma, E. Lagunas, S. Chatzinotas, and B. Ottersten, "Application of compressive sensing in cognitive radio communications: A survey," *IEEE Commun. Surveys Tuts.*, vol. 18, no. 3, pp. 1838–1860, 3rd Quart., 2016.
- [107] G. Shi, J. Lin, X. Chen, F. Qi, D. Liu, and L. Zhang, "UWB echo signal detection with ultra-low rate sampling based on compressed sensing," *IEEE Trans. Circuits Syst. II, Exp. Briefs*, vol. 55, no. 4, pp. 379–383, Apr. 2008.
- [108] W. Wang, "Under-sampling of PPM-UWB communication signals based on CS and AIC," *Circuits, Syst., Signal Process.*, vol. 34, no. 11, pp. 3595–3609, 2015.
- [109] A. Xenaki and P. Gerstoft, "Grid-free compressive beamforming," *J. Acoust. Soc. Amer.*, vol. 137, no. 4, pp. 1923–1935, 2015.
- [110] S. Qin, Y. D. Zhang, M. G. Amin, and B. Himed, "DOA estimation exploiting a uniform linear array with multiple co-prime frequencies," *Signal Process.*, vol. 130, pp. 37–46, Jan. 2017.
- [111] C. J. Colbourn, D. Horsley, and C. McLean, "Compressive sensing matrices and hash families," *IEEE Trans. Commun.*, vol. 59, no. 7, pp. 1840–1845, Jul. 2011.
- [112] Y. Wan, F. Wu, J. Yang, and T. Man, "Multiple-image encryption based on compressive holography using a multiple-beam interferometer," *Opt. Commun.*, vol. 342, pp. 95–101, May 2015.
- [113] X. Liu, W. Mei, and H. Du, "Simultaneous image compression, fusion and encryption algorithm based on compressive sensing and chaos," *Opt. Commun.*, vol. 366, pp. 22–32, May 2016.
- [114] N. Zhou, J. Yang, C. Tan, S. Pan, and Z. Zhou, "Double-image encryption scheme combining DWT-based compressive sensing with discrete fractional random transform," *Opt. Commun.*, vol. 354, pp. 112–121, Nov. 2015.
- [115] X. Huang, G. Ye, H. Chai, and O. Xie, "Compression and encryption for remote sensing image using chaotic system," *Secur. Commun. Netw.*, vol. 8, no. 18, pp. 3659–3666, 2015.
- [116] S. Zhao, L. Wang, W. Liang, W. Cheng, and L. Gong, "High performance optical encryption based on computational ghost imaging with QR code and compressive sensing technique," *Opt. Commun.*, vol. 353, pp. 90–95, Oct. 2015.
- [117] L. Su, T. Huang, and J. Yang, "A video forgery detection algorithm based on compressive sensing," *Multimedia Tools Appl.*, vol. 74, no. 17, pp. 6641–6656, 2014.
- [118] R. Fay, "Introducing the counter mode of operation to compressed sensing based encryption," *Inf. Process. Lett.*, vol. 116, no. 4, pp. 279–283, 2016.
- [119] L. N. Sharma, "Coding ECG beats using multiscale compressed sensing based processing," *Comput. Elect. Eng.*, vol. 45, pp. 211–221, Jul. 2015.
- [120] B. Kailkhura, T. Wimalajeewa, and P. K. Varshney, "Collaborative compressive detection with physical layer secrecy constraints," *IEEE Trans. Signal Process.*, vol. 65, no. 4, pp. 1013–1025, Feb. 2017.
- [121] M. Raginsky, S. Jafarpour, R. Willett, and R. Calderbank. (Mar. 2010). "Fishing in Poisson streams: focusing on the whales, ignoring the minnows." [Online]. Available: <https://arxiv.org/abs/1003.2836>
- [122] B. B. Yilmaz and A. T. Erdoğ̃an, "Compressed training adaptive equalization," in *Proc. IEEE Int. Conf. Acoust., Speech Signal Process. (ICASSP)*, Shanghai, China, Mar. 2016, pp. 4920–4924.
- [123] S. Feizi and M. Medard, "A power efficient sensing/communication scheme: Joint source-channel-network coding by using compressive sensing," in *Proc. 49th Annu. Allerton Conf. Commun., Control, Comput.*, Monticello, IL, USA, 2011, pp. 1048–1054.
- [124] K. Elkhail, M. E. Eltayeb, A. Kammoun, T. Y. Al-Naffouri, and H. R. Bahrami, "On the feedback reduction of multiuser relay networks using compressive sensing," *IEEE Trans. Commun.*, vol. 64, no. 4, pp. 1437–1450, Apr. 2016.
- [125] D. Liu, "FIWEX: Compressive sensing based cost-efficient indoor white space exploration," in *Proc. 16th ACM Int. Symp. Mobile Ad Hoc Netw. Comput. (MobiHoc)*, Hangzhou, China, Jun. 2015, pp. 17–26.
- [126] S. A. Razavi, M. Valkama, and D. Cabric, "Covariance-based OFDM spectrum sensing with sub-Nyquist samples," *Signal Process.*, vol. 109, pp. 261–268, Apr. 2015.
- [127] X. X. Zhu and R. Bamler, "Super-resolution power and robustness of compressive sensing for spectral estimation with application to spaceborne tomographic SAR," *IEEE Trans. Geosci. Remote Sens.*, vol. 50, no. 1, pp. 247–258, Jan. 2012.
- [128] Y. Sun, G. Gu, X. Sui, Y. Liu, and C. Yang, "Single image super-resolution using compressive sensing with a redundant dictionary," *IEEE Photon. J.*, vol. 7, no. 2, pp. 1–11, Apr. 2015.
- [129] Y. De Castro, F. Gamboa, D. Henrion, and J.-B. Lasserre, "Exact solutions to super resolution on semi-algebraic domains in higher dimensions," *IEEE Trans. Inf. Theory*, vol. 63, no. 1, pp. 621–630, Jan. 2017.
- [130] A. Cichocki and A. Phan, "Fast local algorithms for large scale nonnegative matrix and tensor factorizations," *IEICE Trans. Fund. Electron., Commun. Comput. Sci.*, vol. E92.A, no. 3, pp. 708–721, 2009.
- [131] P. Nagesh and B. Li, "A compressive sensing approach for expression-invariant face recognition," in *Proc. IEEE Conf. Comput. Vis. Pattern Recognit.*, Miami, FL, USA, Jun. 2009, pp. 1518–1525.
- [132] L. Qiao, S. Chen, and X. Tan, "Sparsity preserving projections with applications to face recognition," *Pattern Recognit.*, vol. 43, no. 1, pp. 331–341, 2010.
- [133] J. F. Gemmeke, H. Van Hamme, B. Cranen, and L. Boves, "Compressive sensing for missing data imputation in noise robust speech recognition," *IEEE J. Sel. Topics Signal Process.*, vol. 4, no. 2, pp. 272–287, Apr. 2010.
- [134] A. Akl, C. Feng, and S. Valaee, "A novel accelerometer-based gesture recognition system," *IEEE Trans. Signal Process.*, vol. 59, no. 12, pp. 6197–6205, Dec. 2011.
- [135] S. Sivapalan, R. K. Rana, D. Chen, S. Sridharan, S. Denmon, and C. Fookes, "Compressive sensing for gait recognition," in *Proc. Int. Conf. Digit. Image Comput. Techn. Appl.*, Noosa, QLD, Australia, 2011, pp. 567–571.
- [136] A. K. Bhateja, S. Sharma, S. Chaudhury, and N. Agrawal, "Iris recognition based on sparse representation and k -nearest subspace with genetic algorithm," *Pattern Recognit. Lett.*, vol. 73, pp. 13–18, Apr. 2016.

- [137] J. Wright, Y. Ma, J. Mairal, G. Sapiro, T. S. Huang, and S. Yan, "Sparse representation for computer vision and pattern recognition," *Proc. IEEE*, vol. 98, no. 6, pp. 1031–1044, Jun. 2010.
- [138] T. T. Do, Y. Chen, D. T. Nguyen, N. Nguyen, L. Gan, and T. D. Tran, "Distributed compressed video sensing," in *Proc. 16th IEEE Int. Conf. Image Process. (ICIP)*, Cairo, Egypt, Nov. 2009, pp. 1393–1396.
- [139] S. Mun and J. E. Fowler, "Residual reconstruction for block-based compressed sensing of video," in *Proc. Data Compress. Conf.*, Snowbird, UT, USA, 2011, pp. 183–192.
- [140] A. Veeraraghavan, D. Reddy, and R. Raskar, "Coded strobing photography: Compressive sensing of high speed periodic videos," *IEEE Trans. Pattern Anal. Mach. Intell.*, vol. 33, no. 4, pp. 671–686, Apr. 2011.
- [141] M. Edgar et al., "Real-time 3D video utilizing a compressed sensing time-of-flight single-pixel camera," *Proc. SPIE*, vol. 9922, p. 99221B, Sep. 2016.
- [142] D. Giacobello, M. G. Christensen, M. N. Murthi, S. H. Jensen, and M. Moonen, "Retrieving sparse patterns using a compressed sensing framework: Applications to speech coding based on sparse linear prediction," *IEEE Signal Process. Lett.*, vol. 17, no. 1, pp. 103–106, Jan. 2010.
- [143] V. Abrol, P. Sharma, and A. K. Sao, "Voiced/nonvoiced detection in compressively sensed speech signals," *Speech Commun.*, vol. 72, pp. 194–207, Sep. 2015.
- [144] H. You, Z. Ma, W. Li, and J. Zhu, "A speech enhancement method based on multi-task Bayesian compressive sensing," *IEICE Trans. Inf. Syst.*, vol. 100, no. 3, pp. 556–563, 2017.
- [145] A. Asaei, M. Cernak, and H. Bourlard, "On compressibility of neural network phonological features for low bit rate speech coding," in *Proc. Interspeech*, 2015, pp. 418–422.
- [146] S. N. George, N. Augustine, and D. P. Pattathil, "Audio security through compressive sampling and cellular automata," *Multimedia Tools Appl.*, vol. 74, no. 23, pp. 10393–10417, 2014.
- [147] Z. Koldovský, J. Málek, and S. Gannot, "Spatial source subtraction based on incomplete measurements of relative transfer function," *IEEE/ACM Trans. Audio, Speech, Language Process.*, vol. 23, no. 8, pp. 1335–1347, Aug. 2015.
- [148] G. N. Lilis, D. Angelosante, and G. B. Giannakis, "Sound field reproduction using the Lasso," *IEEE Trans. Audio, Speech, Language Process.*, vol. 18, no. 8, pp. 1902–1912, Nov. 2010.
- [149] P. Harris, R. Philip, S. Robinson, and L. Wang, "Monitoring anthropogenic ocean sound from shipping using an acoustic sensor network and a compressive sensing approach," *Sensors*, vol. 16, no. 3, p. 415, 2016.
- [150] Z. Lei, K. Yang, R. Duan, and P. Xiao, "Localization of low-frequency coherent sound sources with compressive beamforming-based passive synthetic aperture," *J. Acoust. Soc. Amer.*, vol. 137, no. 4, pp. EL255–EL260, 2015.
- [151] D. Shamsi, P. Boufounos, and F. Koushanfar, "Noninvasive leakage power tomography of integrated circuits by compressive sensing," in *Proc. ACM/IEEE Int. Symp. Low Power Electron. Design (ISLPED)*, Bengaluru, India, Aug. 2008, pp. 341–346.
- [152] F. Koushanfar, P. Boufounos, and D. Shamsi, "Post-silicon timing characterization by compressed sensing," in *Proc. IEEE/ACM Int. Conf. Comput.-Aided Design*, San Jose, CA, USA, Nov. 2008, pp. 185–189.
- [153] T. Tuma, S. Rooney, and P. Hurley, "On the applicability of compressive sampling in fine grained processor performance monitoring," in *Proc. 14th IEEE Int. Conf. Eng. Complex Comput. Syst.*, Potsdam, Germany, Jun. 2009, pp. 210–219.
- [154] P. Torruella et al., "3D visualization of the iron oxidation state in FeO/Fe₃O₄ core-shell nanocubes from electron energy loss tomography," *Nano Lett.*, vol. 16, no. 8, pp. 5068–5073, 2016.
- [155] C. Liao, J. Tao, X. Zeng, Y. Su, D. Zhou, and X. Li, "Efficient spatial variation modeling of nanoscale integrated circuits via hidden Markov tree," *IEEE Trans. Comput.-Aided Design Integr. Circuits Syst.*, vol. 35, no. 6, pp. 971–984, Jun. 2016.
- [156] W. Zhang, X. Li, F. Liu, E. Acar, R. A. Rutenbar, and R. D. Blanton, "Virtual probe: A statistical framework for low-cost silicon characterization of nanoscale integrated circuits," *IEEE Trans. Comput.-Aided Design Integr. Circuits Syst.*, vol. 30, no. 12, pp. 1814–1827, Dec. 2011.
- [157] H. Huang, H. Yu, C. Zhuo, and F. A. Ren, "A compressive-sensing based testing vehicle for 3D TSV pre-bond and post-bond testing data," in *Proc. Int. Symp. Phys. Design (ISPD)*, Santa Rosa, CA, USA, 2016, pp. 19–25.
- [158] Y. C. Chen, A. D. Domínguez-García, and P. W. Sauer, "A sparse representation approach to online estimation of power system distribution factors," *IEEE Trans. Power Syst.*, vol. 30, no. 4, pp. 1727–1738, Jul. 2015.
- [159] R. Ghosh, B. Chatterjee, and S. Chakraborty, "A low-complexity method based on compressed sensing for long term field measurement of insulator leakage current," *IEEE Trans. Dielectr. Electr. Insul.*, vol. 23, no. 1, pp. 596–604, Feb. 2016.
- [160] K. Hayashi, M. Nagahara, and T. Tanaka, "A user's guide to compressed sensing for communications systems," *IEICE Trans. Commun.*, vol. E96, no. 3, pp. 685–712, 2013.
- [161] S. Qaisar, R. M. Bilal, W. Iqbal, M. Naureen, and S. Lee, "Compressive sensing: From theory to applications, A survey," *J. Commun. Netw.*, vol. 15, no. 5, pp. 443–456, Oct. 2013.



MEENU RANI (S'16) received the B.Tech. and M.Tech. degrees in VLSI design from NIT Kurukshetra, Kurukshetra, India, in 2008 and 2012, respectively. She is currently pursuing the Ph.D. degree with the Visvesvaraya National Institute of Technology, Nagpur, India. She served as a Polytechnic Lecturer from 2008 to 2010 and as an Assistant Professor with Sharda University, Greater Noida, India, from 2012 to 2014. Her research interests include the signal processing using compressive sensing, pattern recognition, and CMOS VLSI design. She received the Teaching Assistantship from the Ministry of Human Resource Development.



S. B. DHOK received the Ph.D. degree in electronics engineering from the Visvesvaraya National Institute of Technology, Nagpur, India. He is currently an Associate Professor with the Centre for VLSI and Nanotechnology, Visvesvaraya National Institute of Technology, Nagpur, India. He has published many research papers in national and international journals and conferences. His area of interest includes signal processing, image processing, data compression, wireless sensor networks, and VLSI design. He is a member of the IEEE society.



R. B. DESHMUKH (M'17) received the Ph.D. degree in electronics engineering from the Visvesvaraya National Institute of Technology, Nagpur, India. He is currently a Professor with the Centre for VLSI and Nanotechnology, Visvesvaraya National Institute of Technology, Nagpur, India. He has published many research papers in national and international journals and conferences. His area of interest includes digital design, CMOS design, and reconfigurable FPGA design. He is a member of the IEEE Society.

• • •