

Received October 5, 2016, accepted October 19, 2016, date of publication October 31, 2016, date of current version November 18, 2016.

Digital Object Identifier 10.1109/ACCESS.2016.2621752

Internet of Things Based Energy Aware Smart Home Control System

MURAD KHAN, BHAGYA NATHALI SILVA, AND KIJUN HAN

School of Computer Science and Engineering, Kyungpook National University, Daegu 702-701, South Korea

Corresponding author: K. Han (kjhan@knu.ac.kr)

This work was supported in part by the BK21 Plus Project SW Human Resource Development Program for Supporting Smart Life by the Ministry of Education, School of Computer Science and Engineering, Kyungpook National University, South Korea, under Grant 21A20131600005, and in part by Basic Science Research Program through the National Research Foundation of Korea(NRF) funded by the Ministry of Education(2016R1D1A1B03933566).

ABSTRACT The concept of smart home is widely favored, as it enhances the lifestyle of the residents involving multiple disciplines, i.e., lighting, security, and much more. As the smart home networks continue to grow in size and complexity, it is essential to address a handful among the myriads of challenges related to data loss due to the interference and efficient energy management. In this paper, we propose a smart home control system using a coordinator-based ZigBee networking. The working of the proposed system is three fold: 1) smart interference control system controls the interference caused due to the co-existence of IEEE 802.11x-based wireless local area networks and wireless sensor networks; 2) smart energy control system is developed to integrate sunlight with light source and optimizes the energy consumption of the household appliances by controlling the unnecessary energy demands; and 3) smart management control system to efficiently control the operating time of the electronic appliances. The performance of the proposed smart home is testified through computer simulation. Simulation results show that the proposed smart home system is less affected by the interference and efficient in reducing the energy consumption of the appliances used in a smart home.

INDEX TERMS ZigBee, interference, IEEE 802.11x, WLAN, smart home.

I. INTRODUCTION

The emergence of smart devices has boosted the concept of connecting everyday objects via the existing networks. The drastic increase of connected devices has outreached the boundaries of the conventional networks, resulting the renaissance of the web as the third wave “Internet of Things (IoT)”. IoT is rapidly growing network of heterogeneous devices and objects, which are uniquely addressable within the network and capable of identifying and sharing information with or without human interaction. Consequent to the development of everyday objects embedded with minuscule and machine-readable identifiers i.e. Radio Frequency Identification (RFID), IoT has become a remarkable spotlight among diversified interest groups. The IoT concept is matured with the extensive attention, leading towards the innovation of novel applications i.e. smart home, smart transportation, smart healthcare, smart industry, etc. Initially, the smart home concept was coined for better management mechanisms with the rapid increase of using smart devices for domestic purposes [1]. However, this notion has revolutionized from switching on lights to security systems, heating control

systems, remotely controllable devices, smart device management, enhance energy consumption, etc. [2]–[4].

The dramatic increase of energy consumption accelerates the demand, resulting a relative increase in the monetary value of energy. Thus, creating a crucial demand to implement smart home applications focusing on consuming energies efficiently in residential buildings. Unintentionally, it influences positively on the energy consumption habits of the residents, meanwhile creating an energy saving, demand reducing and low carbon emission phenomenon [5]. Synthesizing new connections with home automation bring about more realistic and energy efficient smart home concepts. The home automation is widely used for central controlling of lighting, heating, ventilation and air conditioning appliances (HVAC) and security locks. Regardless of the purpose, smart home applications extensively rely on WSN. Among multiple technologies, WIFI seems to be advantageous due to its higher bandwidth, large coverage, easy expansion, etc. [6]. However, its power consumption is higher compared to Bluetooth and ZigBee, which are widely accepted as the ideal communication protocols for resource constrained

sensor devices. In fact, the technologies operate on the same ISM band i.e. WIFI, ZigBee, and Bluetooth (2.4 GHz), cause network interference in the WSN leading to a massive data loss [7]. It is a compelling requirement to address this regard, to enhance the Quality of Service (QoS) provided by smart home applications.

However, implementing an efficient smart home control system under heterogeneous WSN is a challenging task. One of the major challenges in this regard is the standardization of IoT. Thus, making IoT as a standard can help the researchers in providing a common platform for producing products and services for smart home designing. Therefore, multiple attempts have made in order to overcome the technology and application demands, while adapting to dynamicity of service requests. A resource-aware smart home management system was proposed with an effective mechanism for managing home resources and presents a base architecture for autonomic services is presented in [1]. Similarly, the integration of ZigBee with IEEE 802.15.4 is capable of delivering effective solutions in multiple interest areas i.e. energy management and efficiency, building automation, industrial plant management, etc. [8]. For example, DOMotics and SECurity (DOMOSEC) home automation system proposes a novel communication protocol that connects the architecture's IP-based elements through UDP employing ZigBee technology [2]. Moreover, the DOMOSEC has been evolved to adapt into multiple settings with regards to the contextual requirement i.e. greenhouse, e-health, elderly care, and energy efficiency. However, DOMOSEC does not provide any solution to avoid interference and control packet loss, which can ultimately affect the performance of the smart home automation system. Similarly, many other challenges are present in the current literature such as high-energy consumption, high packet loss due to the co-existence of heterogeneous technologies, smart light control systems, etc.

In this paper, we, therefore, proposed a smart home control system based on CoZNET to mitigate the effect of interference and reduces the energy consumption of the smart home appliances. The proposed interference control system divides the wireless channels among the sensor nodes and the WIFI users based on Multi-Attribute Decision Modeling (MADM). Similarly, a smart light control system is used to tune the illumination level in a room by incorporating the natural light. A management station is designed to control the working time of the smart home appliances. The simulation results reveal that the proposed CoZNET in integration with the management station delivered an energy and interference aware solution than a relay and pure WSN based smart home systems.

II. STATE OF THE ART

The recent emerging smart home services provide various benefits ranging from improving customer experience to energy usage efficiency. However, designing a generic

communication model integrating each entity of the smart home system is still a challenging job. Since, IoT and M2M plays an important role in enabling communication between different objects in a smart home and smart city, therefore, several smart homes and cities are based on these new communication systems. For example, an architecture solving various smart city issues such as dealing with unreliable objects, enhancing resilience capabilities, automatic aggregation of data from sensors and different Virtual Objects (VO), health care systems, etc. based on Composite VO (CVO) has been proposed in [9]. The CVO is responsible for providing services to the applications based on a cognitive mixture of semantically interoperable VOs. Moreover, the CVO architecture operates in three cognition levels i.e. 1) In the case of VO level, the cognition is performed to enable self-management and self-configuration, 2) The CVO level enables cognition functionality to perform the application requirement services, and 3) In the service level, the cognition is performed to capture the application requirements. The proposed system is tested in a specific scenario and therefore, it cannot guarantee the similar services in a generic environment. In fact, the energy consumption of the smart home appliances is a critical task, which requires great care and management while addressing. To test the IoT in a generic environment, recently researchers proposed several techniques. For instance, energy-aware smart home systems are proposed in [10] and [11]. The authors developed a smart controller scheduling system to efficiently the energy consumption of the household appliances. A dynamic programming-based algorithm is designed to control the activities of the smart home individuals. However, to maintain and manage the behavior of each individual requires a context-aware mechanism. Thus, highly increases the complexity of the system by adding extra modules to the system. Therefore, instead of wasting efforts on the design of a smart home which require high modification in the existing architecture. It is better to remain focused on the energy consumption of the household appliances using WSN technology. The sensors technology helps in controlling the household appliances through self-management. Moreover, self-management functionality in integration with WSN widely helps in reducing the unnecessary electricity consumption of the household appliances. In [12], the authors developed an Energy Communication Unit (ECU) to record the energy usage of the household appliances and perform necessary actions such as supplying and blocking the electrical energy to a household appliance. Moreover, a communication module is proposed based on ZigBee technology to transfer energy, power, voltage and current consumed by a household appliance to a central home server. In [13], the authors proposed a Home Energy Management (HEM) system for power consumption control based on a predefined voltage threshold during peak hours. The HEM follows a customer experience model to achieve high customer comfort level. Moreover, based on a user experience a local profile model for weekdays and weekends is designed to keep the system updated with the

latest customer experience. Furthermore, the load profile helps in adjusting the usage of the power consumption of the household appliances by tuning the required voltage.

Renewable energy sources such as wind turbine, solar panels, etc. are largely incorporated with the existing energy sources to reduce electricity expenses. The recent literature consists of various methods to integrate the renewable energy sources in smart home scenarios. However, the management and maintenance of various energy sources are some of the challenging jobs. In this regard, in [14], the authors presented a scheduling technique of electrical and thermal appliances based on resident behavior, weather conditions, discomfort index, etc. The energy of various renewable energy sources is computed and incorporated it for operating various home appliances such as a boiler, vacuum cleaner, etc. However, implanting the renewable energy sources in each home is a difficult job because of various environmental conditions, etc. Several companies investigating the smart home systems such as Apple developed a home kit based on a software framework to control household appliances [15]. Similarly, Amazon provides a complete solution from designing to operating a smart home [16]. The Qualcomm offers various smart home services to improve the communications architecture of a smart home [17]. However, those services are mostly based on advanced solutions which require 24/7 connectivity to a high data rate internet service. Thus, providing high data rate internet service increases the chance of interference in a smart home environment. Therefore, an efficient communication model is required to lessen the occurrence of interference due to the heterogeneous technologies present in a smart home [18]. Recently, various interference-aware communication models have been proposed based on a fair communication between low data rate technologies such as WIFI, 3G, LTE, LTE-A, etc. For example, a Disjoint Multi-Path Routing (DMPR) protocol based on Kruskal's algorithm is proposed in [8]. Whenever a sensor node wants to transfer a data packet to the management stations, the sensor node always selects the next hop with the best Kruskal's algorithm value. The DMPR follows a relay based WSN networks architecture. In the relay based WSN, each sensor node acts as a relay node for other nodes. However, relay based WSN suffered from high packet loss, if the physical distance between the relay node and the other technologies is less than 3 meters [19]. Several efforts have been made to mitigate the effect of interference caused due to the co-existence of WSN and other technologies. For instance, in [20], the authors presented a scheme called Proactive Dummy-byte Preamble padding (PDBPP) to mitigate the effect of interference by analyzing the data obtain in the co-existence of ZigBee and WIFI technologies. The proposed mechanism significantly improve the performance of packet transmission in terms of minimizing the packet loss and maximizing the transmission efficiency. Implementing such systems in a smart home scenario requires modifications in the existing architecture of the WLAN packet format. Thus, the practical

usage of such architecture is beyond the reality because of the already installed infrastructure.

Summarizing, the above literature reveals some important challenges that need to be addressed. For example, most of the energy management systems work in a specific environment, the modifications in the existing infrastructure, co-existence of heterogeneous technologies, etc. Finally, we identify the need for an efficient communication model for IoT-based smart home systems.

III. SMART HOME SERVICES

In general, electrical loads of a smart home can be categorized into constant current loads, constant impedance loads, and constant power loads [13]. Constant current and constant impedance loads are known as passive loads, since the power consumption is varying according to the voltage level. Therefore, these loads are also known as manageable loads [21]. In [22], passive loads are further classified into three sub categories i.e. shiftable loads, interruptible loads, and weather based loads. Appliances with significant power consumption and capable of affording flexible delays belong to shiftable loads e.g. washing machine. Interruptible loads appliances consume fixed energy while being in ON state. However, their ON cycle relies on user requirements e.g. refrigerator [21]. Air conditioner is a weather based load appliance, which operation depends on climatic changes. Constant power loads are non-manageable loads, since it requires maintaining a static power level by altering other parameters.

In fact, the consideration on electrical load is crucial for the management of energy consumption in smart homes. However, a majority of recent literatures were focused on managing passive electrical loads. The rationale for this notion is most of the home appliances belong to manageable loads category. This idea was further established and supported, since manageable appliances, e.g. washing machine, refrigerator, air conditioner, etc. have a comparatively higher energy consumption than non-manageable appliances e.g. television and lights. Further, a larger portion of efforts were aimed to manage energy consumption by shifting electrical loads of household appliances [23], [24]. Further, load shifting is mainly considered for manageable loads, which leaves out nearly 30% of household appliances [13]. Therefore, in this study we propose a smart home energy management scheme that manages both active and passive electrical loads considering immediate user behaviors without involving any shifting mechanism.

A. SMART HOME APPLIANCES

We consider a smart home environment consists with major appliances that are used in a general household i.e. refrigerator, air conditioner (AC), washing machine with dryer, dish washer, lights, etc. In fact, electricity consumption and cycle completion time are varying from one appliance to another. Moreover, power consumption is variable for an appliance depending on the phase of the execution cycle e.g. for a time unit, power consumption of washing cycle is less

than the power consumption of drying cycle of a washing machine. Thus, it is worthy to determine exact durations for the completion of cycles and power consumption vector at definite time slots. On one hand, these measurements can be found experimentally by measuring power consumption at similar time intervals until the end of execution cycles. On the other hand, these can be revealed from appliance specifications.

Refrigerator works continuously throughout the day. However, the compressor of the refrigerator rests when 1) the inside temperature drops below the set temperature and 2) in defrost heating process. The power loads of refrigerator fluctuate between 0.37 kW and 0 kW. It reaches the peak during defrosting process. The cooling element of the refrigerator is heated to melt down surrounding frost. Thus, it requires more energy, which reaches the power load peak. Refrigerators consume approximately 3.4 kWh per day. The dishwasher operates in three phases to complete a single operation cycle 1) wash, 2) rinse, and 3) dry. In general, the dishwasher operation cycle takes about 105 minutes. Power load of the dishwasher varies from 1.2 kW to 0.6 kW during the operation cycle. The lapse time between wash and rinse phase consume 0.2 kW power load. Further, the power load demand depends on the inner material of the dishwasher i.e. stainless steel and plastic. Approximately a dishwasher's power consumption is 1.44 kWh per one cycle. Dishwashers are flexible for delayed operation, thus belong to shiftable load appliances. Washing machine is another important appliance in household. We considered clothes dryer operates sequentially after the completion of washing machine's cycle. Washing machine also complete wash, rinse, and dry tasks to complete a single cycle. It takes around 45 minutes to complete all three tasks. The power load of the washing machine varies from 0.52 kW to 0.65 kW. The clothes dryer starts 15 minutes after the completion of washer's cycle. The dryer operates for an hour with a power load fluctuating between 2.97 kW and 0.19 kW. Energy consumption for combined appliances is 2.7 kWh per cycle. Both of these appliances belong to shiftable load category. Moreover, the smart home scenario included an AC. It is a compressor based cooling system. The compressor works continuously until the temperature is equal or below the set level. The power load reaches a maximum of 2.75 kW, when the compressor is ON. The compressor is switched OFF when the temperature drops below the set level. However, minimum power load is not 0 kW, since the air fan works continuously to ensure air circulation of the house. Thus, the minimum power load of AC was 0.25 kW. Daily power consumption of the AC is nearly 31 kWh. AC power load belongs to non-shiftable weather based loads. The cooking oven is an appliance that can use more than once within a day. Assume that the oven is used for two times per day, once in the morning and once in the evening. Usually, cooking time is extended in the evening. We assumed that the oven operates for 90 minutes in the evening. The power load for that duration was fluctuated between 2.35 kW and 0.75 kW. Total power consumption for the evening

usage was 1.72 kWh. Lights belong to unmanageable load appliances. The energy consumption of lights is less compared to the above stated appliances. However, the consumption is not negligible, since unnecessary usage of lights can lead to energy wastage. Unlike in most other proposed schemes, iEASH manages power consumption of unmanageable (active) load appliances.

B. SMART HOME SCHEDULING MECHANISMS

This section elaborates on using scheduling of household appliances to minimize the energy consumption. Therefore, the scheduling mechanisms follow environmental factors i.e. weather conditions and home users' routines to propose efficient execution schedules within occupants' comfort zone. Scheduling is further classified into static scheduling and runtime scheduling.

In static scheduling, weather forecast for the day and smart home users' activities schedule have been used to define the models and profiles for smart grid, local energy sources, and home appliances. Moreover, it is assumed that smart grids have variable electricity charges. Whenever the voltage level of a smart grid is equal or greater than the defined threshold, electricity power can not be sold back to the smart grid. Consequent to the smart grid's production and demand electricity cost varies over time. Thus, scheduling of electricity usage is a valuable solution to reduce the total cost of electricity. The cost factors are further reduced by local generation of electricity, which satisfies energy demands of a household with a minimal expenditure. Hence, static scheduling was introduced with the aim of minimizing total cost of electricity considering prior data. Accordingly, static schedules were made on the basis of local power generation capacity, received power supply from smart grid, and energy demand of household appliances. Initially, the static scheduler generates profiles for smart grid, home appliances and local energy sources with aid of previous records of smart grid, energy sources, and appliances usage. In addition, it considers weather forecast for the next day and activity plan of smart home users.

Static scheduling considers planned activities and forecasted weather report to create the electrical usage schedule. However, the reality of weather forecast and occupants activities can be far away from the schedule. Further, smart grid operation, local energy sources, and power demand of home appliances can extend the gap between reality and the schedule. Thus, it is essential to reschedule shiftable appliances to meet power demands at a minimum cost. This procedure is known as runtime scheduling. Runtime scheduling take place when,

- 1) Updated weather forecast is significantly different from the previous forecast at the creation of the static schedule.
- 2) Significant difference in the operation status of local power sources, smart grid, or appliances' power demand. In this scenario, shiftable appliances check the status before start their operation.

Thus, runtime scheduling immensely helps energy saving requirements of the smart home. As it adapts the static schedule according to the current operational status and weather conditions.

IV. PROPOSED FRAMEWORK OVERVIEW

This effort proposes a smart home control system that addresses the issues mentioned before:

- High packet loss caused due to the interference resulted from the coexistence of heterogeneous wireless technologies
- Unnecessary energy consumption by the smart home appliances
- Inappropriate lighting control system, which neglects the natural illumination

To overcome these, we have identified the need for an energy efficient autonomous controlling of the home appliances in an interference free environment, which provides all potential smart home services to meet consumer expectations and application demands.

The backbone of the architecture is the Smart Interference Control System (SICS). The SICS mitigates the coexistence interference in the entire smart home, to provide uninterrupted communication services. Multi-attribute decision-making (MADM) based channel assignment mechanism is proposed in SICS, to ensure resilience in identifying and assigning less interfered channels, dynamically. The channel assignment process to each sensor takes place in collaboration with ZigBee coordinators. Since it facilitates a smoother communication with a minimal packet loss.

The existing Home Energy Management Systems (HEMS) utilize renewable energies such as photovoltaic power and wind power to serve the consumer demands. In order to meet the consumer demands, the energy consumption efficiency is heightened in the smart home scenario with the aid of the smart energy control system (SECS). The SECS is built up with a household appliance control system and a light control system, respectively, supported by ZigBee sensors attached to each electrical appliance and light sensors placed in the smart home.

The piece of component, which manages the functionality of the smart home, is the smart management control system (SMCS). SMCS is the fundamental unit, which provides various facilities to the user in order to exploit the controlling of the entire smart home. Thus, it is called to be the brain of the smart home, as it offers logical decisions for an effective energy consumption, schedules events, stores information in a database, etc. In fact, the SMCS information flow is bi-directional.

- Receive sensor inputs from the coordinators connected to the SMCS
- Send commands to control the appliances attached to the sensor

The complete architecture enables seamless communication with a minimal interference, to facilitate punctual and appropriate controlling of household appliances in order to

reduce the residential energy consumption. The related smart home scenario is clearly illustrated in Figure 1 and the rest of CoZNET system is divided into a three different parts i.e. 1) Smart Interference Control System (SICS), 2) Smart Energy Control System (SECS), and 3) Smart Management Control System (SMCS).

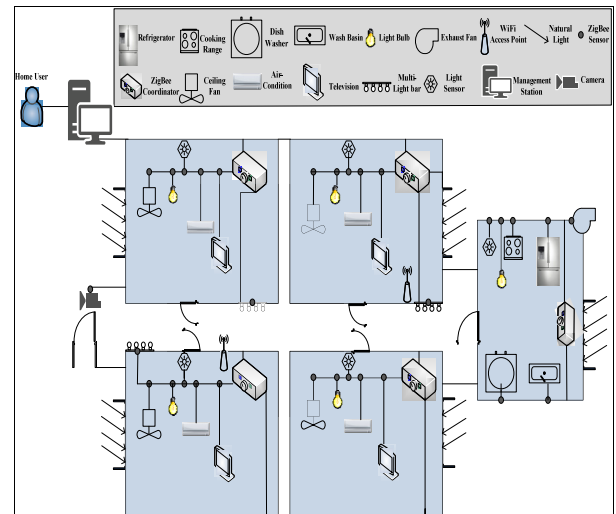

FIGURE 1. Proposed smart home scenario.

A. SMART INTERFERENCE CONTROL SYSTEM (SICS)

The major concern of the CoZNET scheme is to address the key issues identified above with respect to the existing and past efforts. It is revealed that the coexistence of multiple wireless technologies on the same ISM band influences the performance deterioration of each other. The smart home architecture utilizes WLAN and ZigBee WSN, which both operates on the 2.4GHz band, thus resulting the interference. The distance from the Wi-Fi Access Point (AP) is also considered to be another key influential factor for the interference. Hence, the physical distance between the sensors and the Wi-Fi AP is taken into account to bring forth a solution, which addresses the consequences of interference. In the conventional WSN, the sensor nodes communicate with the management station directly or via relay nodes. Thus, causing a significant packet loss due to the high level of interference. In fact, the chances of packet loss are higher, while transferring data packets to a farther destination via sensors or relay nodes. These consequences degrade the performance of the smart home devices and sensors. Accordingly, the coordinators are introduced into the CoZNET scheme. They are placed in each room and kitchen, in order to minimize the packet loss due to the interference caused by coexistence and the distance from sensors to the management station. The physical distance is the vital factor to consider for the coordinator implantation in the smart home. Mindful placement of coordinators ensures less chance of interference. Such stated placement of the coordinators guarantees the resilience of the network to reduce the number of hops to the management station, eventually minimizing the number of packet loss.

Furthermore, the complete collection of the sensors within the smart home environment is divided into n number of groups as per to the distance factor between the sensors and sensor with WIFI AP. However, in this work, we are interested in the interference between the sensors and WIFI AP. The sensors in proximity to the WIFI AP belongs to the first group (G_1). Moreover, the physical distance is less than the distance threshold ($d[\theta]_1$). In a similar way, the remaining sensors are divided into groups i.e. $G_2 \dots G_n$, which adheres to lesser physical distance than the distance thresholds $d[\theta]_1 \dots d[\theta]_n$, respectively. Undoubtedly, the proximity to WIFI AP increases the level of interference, provoking the sensors in G_1 to reach the highest level of interference. Once a ZigBee channel is occupied by a WLAN signal, the possibility of occupying adjacent channels by the WLAN is comparatively high. In order to address this phenomenon, each group G is assigned with a specific set of channels. The G_1 is assigned with non-overlapping channels because the sensor present in this group are closer to the WIFI AP. The rest of the channel assignment is carried out using the MADM decision modeling. The criteria (c) used to select a channel using MADM technique is consists of bandwidth, occupancy, Signal-to-Interference-plus-Noise-Ratio (SINR), and quality. The entire MADM mechanism follows a five-step model as follows.

Step 1 Classifying and normalizing the criteria in a decision matrix

Step 2 Constructing a weighted normalized decision matrix

Step 3 Computing negative and positive ideal situations

Step 4 Finding the separation from negative and positive ideal situations

Step 5 Computing the ranks of the available networks

The weight (w) to each criterion is assigned by $w_i = ci / \sum_{i=2}^k c_i$. After computing the ranks of the available channels, they are arranged in ascending order. The channels with high rank is assigned to groups available at closer distance to the WIFI AP and vice versa. Ultimately, SICS ensures smooth and uninterrupted communication in the smart home environment in the presence of multiple wireless technologies.

B. SMART ENERGY CONTROL SYSTEM (SECS)

Energy management is a major concern in today's world due to various reasons. This component aims to enhance the energy consumption efficiency in accordance with the consumer needs. The energy efficiency of the smart home is achieved with the aid of two sub-components.

- ZigBee sensor supported household appliance control system
- Light sensor supported lighting control system

In this scenario, the energy consumption activities are solely depending on the residents' activities within the home environment. Therefore, the SECS is implemented to operate in a semi-automated manner. Once the user switches on an appliance manually, SECS is capable of switching off the appliance on commands from the management station.

The energy consumption is monitored by means of the functioning time. Whenever the user turns on a device the time is recorded in the management station. As mentioned before, the appliances' activities are controlled corresponding to the user behavior. Therefore, the presence of the user is checking periodically by the SECS. As the user leaves a particular location, all the active appliances are turned off to avoid energy wastage. Simultaneously, the appliance's turned off time is updated in the management station. Differential identification of the appliances is a crucial demand in terms of automated controlling. Thus, each appliance is attached with a ZigBee sensor deployed in the smart home environment. Each sensor is assigned a unique identification number, eventually served to distinguish the appliances from each other. In this context, the awareness of SECS related to the habitants' behavior appliances functioning is crucial. Therefore, the management station handles the communication between the home users with an event management system. The description of the events is provided in the next section.

Apart from the controlling of home appliances, SECS enforces the utilization of natural light by its lighting control system. This promotes energy saving by adjusting the luminance of the smart home light source accordingly. The intensity of the sunlight is computed as a function of the area covered by the sunlight in a room, etc. As shown in Figure 2, four different cases are identified in terms of the situation parameter (θ), which denotes the angle of the sunlight upon the window of a room or any other location. In all the four cases, lighting control system imposes the light sensor to acquire the natural light intensity of the room. Accordingly, the intensity (I) of the smart home light source is adjusted using the following relation.

$$I_{\theta_i} = \begin{cases} \varphi \left[\frac{1}{2}(b1 \times h1) + (b2 \times x) \right] \pm \delta & 0^\circ \leq \theta_1 < 15^\circ \\ \varphi [(b3 \times h2) + (b4 \times h3)] \pm \delta & 15^\circ \leq \theta_2 < 30^\circ \\ \varphi \left[\frac{1}{2}(b6 \times x) + (b5 \times x) \right] \pm \delta & 30^\circ \leq \theta_3 < 45^\circ \\ \varphi \left[\frac{1}{2}(b6 \times x) + (b5 \times x) \right] \pm \delta & 45^\circ \leq \theta_4 < 60^\circ \\ \varphi x^2 & \text{Otherwise} \end{cases} \quad (1)$$

The tuning factor δ regulates the intensity of the smart home light in line with different environmental conditions. The intensity of the luminous flux by a unit length light source is denoted by φ and it is computed as below.

$$\varphi = \frac{F_L \times F_M \times R_f}{\Gamma} \quad (2)$$

Where F_L is the total luminous flux by a light source, F_M is the lumen maintenance of the light source, R_f is the lampshade reflection coefficient, and Γ is the length of the light source.

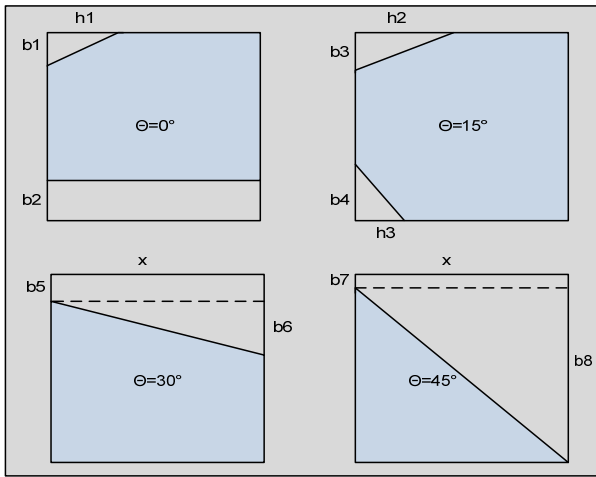

FIGURE 2. Area covered by sunlight at different time of the day.

C. SMART MANAGEMENT CONTROL SYSTEM (SMCS)

Uninterrupted communication channels and acquired situational parameters are not just enough for the realization of an effective smart home energy management system. The processing of gathered data is essential to formulate worthwhile control commands. Hence, the data collected from the sensors and coordinators are sent to the brain of the smart home, SMCS. Not only the processing of data but also organizing the data in the database, decision-making, event generation, performing actions, etc. are performed by SMCS to the empowerment of the smart home performance.

As the gathered data are organized in the database, a threshold value is defined for each service i.e. electricity, gas, and water. Whenever the predefined threshold value is surpassing by any service it is taken as a sign of excessive energy consumption. In this respect, the SMCS periodically checks the service consumption against the predefined threshold. In addition, it triggers to generate an event to notify the smart user about the elevated service consumption. The smart home user has the authority to take necessary actions via remote access functionality. Once the SMCS receives the user acceptance for the event, the respective event is generated and is conveyed to the sensors. For example, if the electricity consumption reaches beyond the threshold, each sensor attached to an electric appliance receives the event generated by the SMCS. Thereupon, the sensor checks for the presence of the user. If the user is available, the SMCS opts to wait until the user leaves, otherwise turn off the corresponding appliances immediately.

In addition to the management of service consumption, the SMCS is capable of generating a monthly record of the utilization of services. In real world situation, the users are benefited if they are allowed to act proactively. Thus, the SMCS provides the statistics of the usage with respect to individual appliances, so that the user can manage them accordingly. As a result, the smart home is operated within the threshold limits for the service consumption. In general, the smart home

user may not be available at a certain time to carry out the decision-making. Hence, the SMCS is automated along with a Human Machine Interface (HMI) for future adjustments, following the smart home user experience. Therefore, the unavailability of the user may not influence adversely to finalize the decisions. The automation system helps the user to adjust different tasks in the smart home such as a refrigerator and air-condition cooling, surveillance system i.e. locking the doors, etc. These functionalities help the user in reducing the energy consumption of the devices and ultimately helps in low bills, etc.

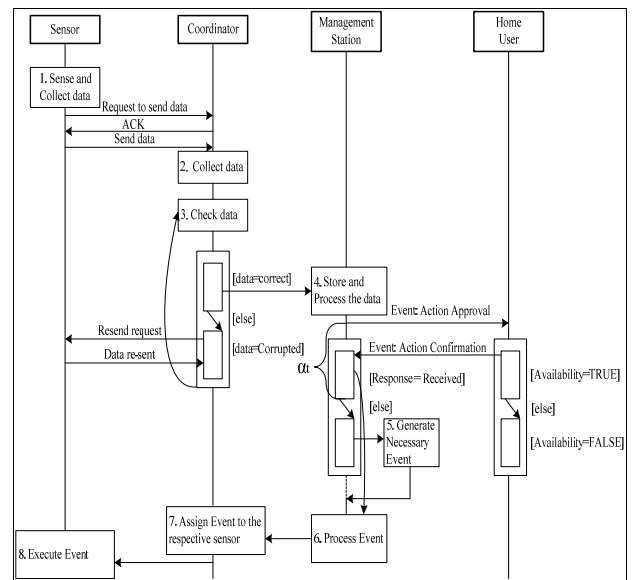

FIGURE 3. Working of the SMCS module.

An example scenario of the operation of the SMCS is shown in Figure 3. Initially, a sensor collects data and then make a connection with the coordinator. During the connection, the sensor and coordinator synchronize on a particular channel. After the connection, the sensor sends data to the coordinator. The coordinator collects the data and assigns a sequence number to the respective sensor. In order to ensure the error-free data, the coordinator checks the data. If the data is corrupted, the coordinator sends a resend request to the sensor. After ensuring the correct data from the sensor, the coordinator sends the data to the management station. The management station stores the data based on the sequence number of the coordinator and generates an event i.e. Action Approval to the home user. The management station waits for a particular amount of time i.e. Waiting Time (α_t) for the confirmation event. Once the α_t expires the management station, generates an event based on the previous responses of the home user by concerning the HMI module. On the other hand, if the user responded before expiration of α_t , the management station sends the respective event to the respective coordinator. Similarly, the coordinator sends the event to the respective sensor for execution.

V. PERFORMANCE EVALUATION

The co-existence of the heterogeneous wireless network highly affect the performance of the smart home entities such as home users, sensor, and the electronic appliances. The existing techniques of smart home design do not consider the interference caused due to the heterogeneous technologies. Therefore, the interference mainly affects the communication between sensors and sensor and coordinator, etc. Moreover, natural light can be use with the light source to illuminate the home. In this section, we evaluate the interference caused due to the co-existence of heterogeneous technologies and a solution of integrating the natural light with light sources. Two different scenarios are simulated i.e. 1) single user in a single room with various household appliances and 2) multiple users with various rooms and household appliances.

The performance is evaluated in the C# programming language. A smart home is designed with fixed WIFI APs and a various number of home users. The users are performing two different type of tasks i.e. 1) constantly generating traffic with a packet size from 1000 to 5000 bytes and 2) randomly switches on and off a household appliance. The entire smart home is tested for all the electronic appliances for a duration of 6 hours. Both the energy consumption by the sensors and appliances is computed by taking the user activity as a random variable between 5 to 30 seconds except for the burner in the kitchen. In order to be more realistic, the simulation time for the gas burner is changed to 5 to 15 minutes. Moreover, we deployed various light sources in a different room with F_L , L_M , R_f , and Γ of 1700 lm, 65%, 2.16 and 330 mm, respectively. The entire room size is set to 3000 mm × 3000 mm. The home user stays in one particular room for 5 to 10 minutes while randomly turning on and off the appliances available in the room.

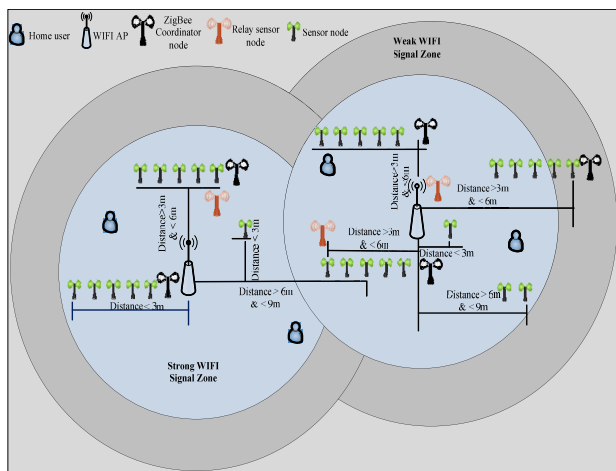
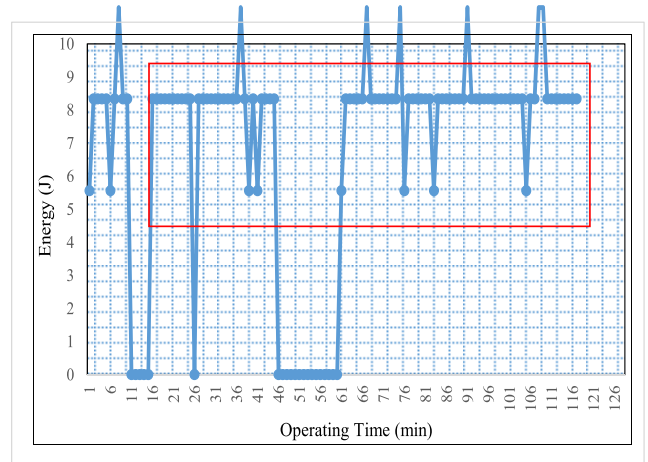

FIGURE 4. The simulation scenario.

A. SIMULATION SCENARIO AND RESULTS

To evaluate the proposed interference avoidance technique and the smart energy management system under the interference of a WIFI AP, a home scenario is considered with



(a) Load profile of refrigerator

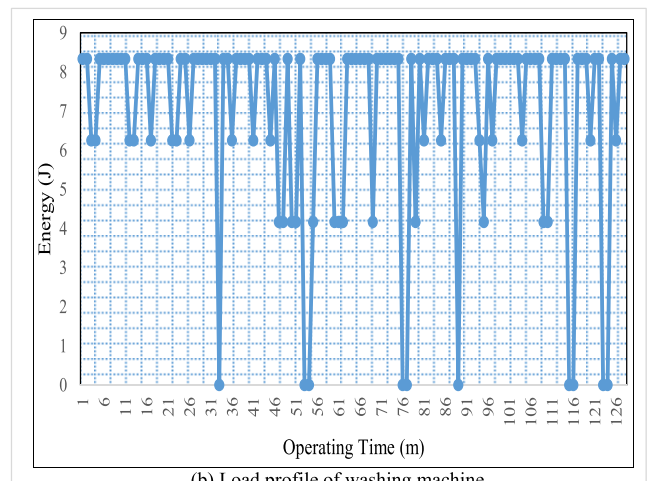

(b) Load profile of washing machine

FIGURE 5. Load profile of refrigerator and washing machine. (a) Load profile of refrigerator. (b) Load profile of washing machine.

four home users, two WIFI APs and several ZigBee sensors as shown in Figure 4. Each household appliance is connected with a sensor, which is further connected with a ZigBee coordinator. The ZigBee coordinator is responsible for aggregating data from the sensors attached to each appliance and send it to the management station. Each home user is continuously generating unicast data packets to the WIFI AP. Similarly, the same environment is tested with a relay and pure WSN based networking. Furthermore, the relay sensor nodes are not configured to sense data; they are only used to forward the data to the next available hop. To be more realistic, the relay nodes are tested in both near and far locations from the WIFI AP. Four group of sensors are considered in the entire home scenario. The first group is available at a very close distance ($d[\theta]_1 < 3m$) to the WIFI AP. The second, third, and fourth group is available at a distance $d[\theta]_2 < 6m$, $d[\theta]_3 < 9m$, and $d[\theta]_4 < 13m$, respectively. Similarly, each sensor is programmed to sense the device status (switch on or off) periodically after each 10 seconds. The amount of power requires to operate a device is fixed based on the standard energy consumption units.

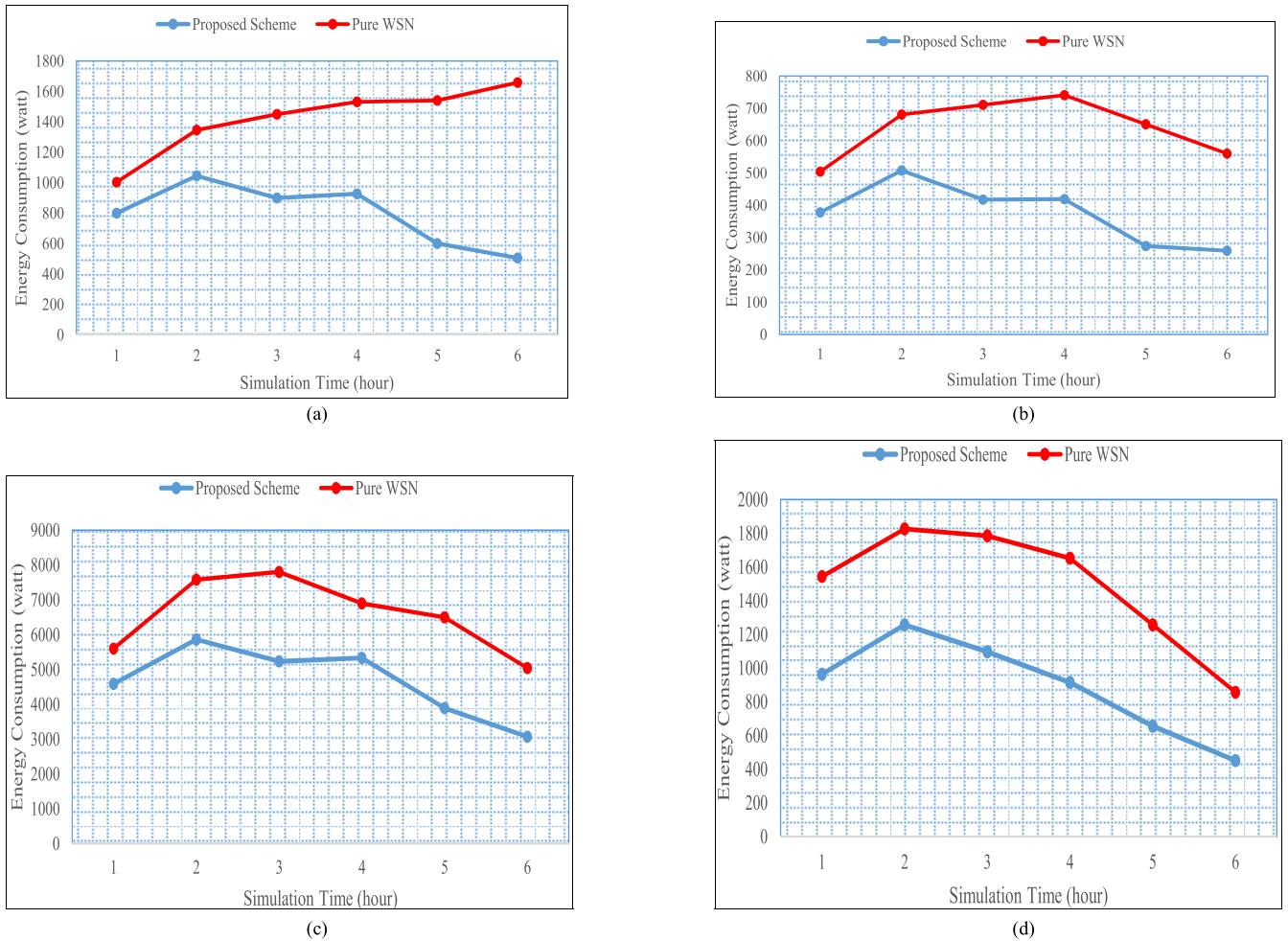
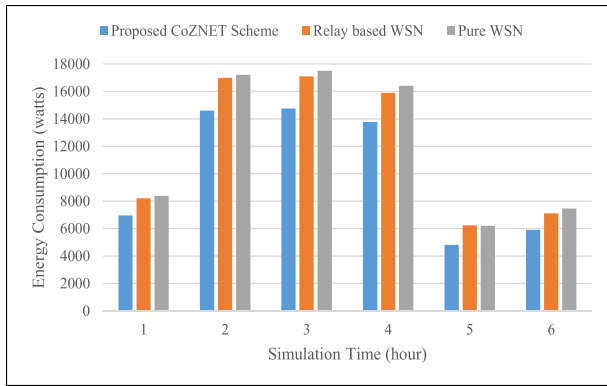

FIGURE 6. Energy consumption of various home appliances. (a) Energy consumption of the Television. (b) Energy consumption of the Fan. (c) Energy consumption of the Air-conditioning system. (d) Energy consumption of the Refrigerator.

The load profile of refrigerator and washing machine during different daytime is shown in Fig. 5 (a), (b), (c) and (d). The load profile of each appliance helps in designing an optimal scheduling of the appliances used in the smart home. However, our main concern is to find out various patterns that helps in reducing the energy consumption during off time. For example, if a smart home user is not able to switch off a home appliance, the system automatically switch off the appliance, if it is operating without any significance. Moreover, the load profile is used to assign a schedule to each appliance. This makes the process autonomous. Therefore, without the smart home user intervention, an efficient scheduling technique can be designed. However, performing autonomous decisions is still a challenging job because it directly depends on the human behavior. On the other hand, require load of each appliance helps in designing a semi- autonomous system. For example, the load profile of the refrigerator as shown in Fig. 5 (a) helps in the designing of such system, if a similar number of patterns (boxed with red color) are computed for a duration of a week or a month. The washing machine load profile is high on weekends as shown in Figure 5 (b). Thus, it

reveals that the washing machine is always operates by the user on weekends. Therefore, to maintain a uniform load balancing among the appliance for the entire week or month, it is important to efficiently optimize the workload among the appliances.

In the case of relay based WSN, three relay sensors are used to forward data to the next available hop. In the case of pure WSN, the sensors attached with the household appliances can switch on and off a household appliance without concerning the management station. Such systems do not keep the record of the operating time of a household appliance. Therefore, the home user is unable to adjust the household appliance for better usage concerning the previous history of the household appliances. In particular, these systems does not provide the functionality of smartness and thus not suitable to use in the future IoT-based smart home systems. However, the proposed CoZNET system provides the functionality of managing the household appliances operating time based on the previous record. Moreover, the SMCS is able to generate necessary events, if the home user is not available or offline. The energy consumption of the household appliances such as television,



(a). Energy consumption of the light source

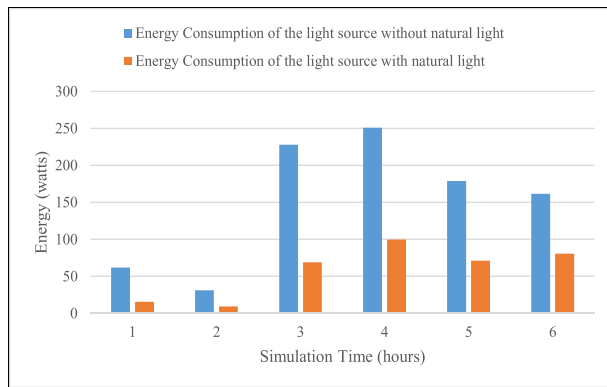

(b). Energy consumption of the light source without natural light

FIGURE 7. Energy consumption of the light source employing proposed scheme. (a) Energy consumption of the light source. (b) Energy consumption of the light source without natural light.

fan, air-conditioning system, and refrigerator is tested in the case of proposed system and pure WSN as shown in Fig 6 (a), (b), (c), and (d), respectively. The energy consumption of the appliances is significantly reduced. The proposed scheme perform switching on and off an appliance based on the user context. Thus, inappropriate energy consumption is saved in the case of proposed scheme. Moreover, the user is controlling the appliances energy consumption by checking the daily and monthly records. Thus, a user is able to maintain an optimal energy consumption level of the appliances.

The light source in room 1 is tested with and without the natural light. In order to ensure a real time scenario, we performed an intuitive test in our laboratory for the sunlight falling on the window at the different time of the day. The intensity of the natural light falling on the window is computed at a different time starting from 8:00 AM to 2:00 PM. Initially, the natural light covers the maximum portion of the room. However, after 12 PM, the sunlight reduces and covers almost half of the room. This experiment reveals that the natural light in daytime can be used with the light source to save the energy as shown in Figure 6 (a). Similarly, the energy consumption of the rest of the devices except burner, washbasin, dishwasher, and light source in the home is significantly reduced as shown in Figure 6 (b). In order to reflect a real-time environment, for the first and last two

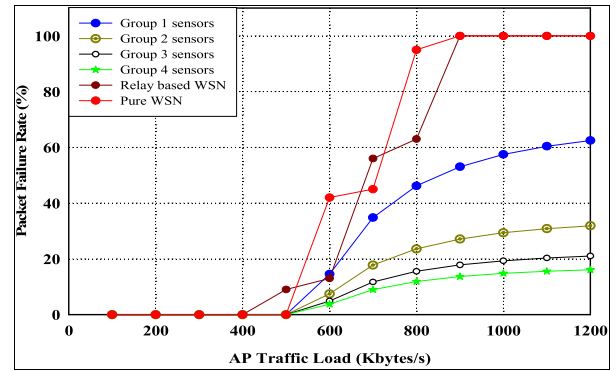

(a). Average packet failure rate in all groups

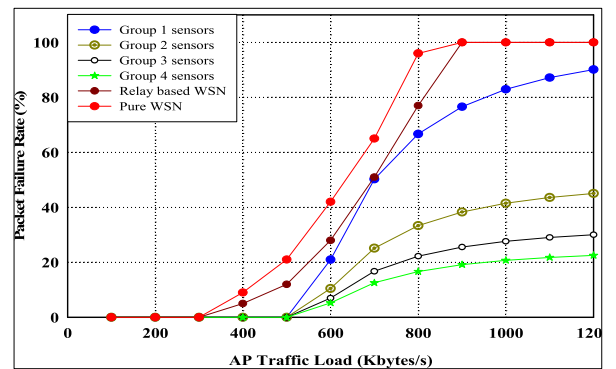

(b). Maximum packet failure rate in all groups

FIGURE 8. Average packet failure in various groups of sensors. (a) Average packet failure rate in all groups. (b) Maximum packet failure rate in all groups.

hours, the user activity is kept low. However, for the rest of the hours, it is kept to 100%. The results show that the proposed scheme save an average of 15% electrical energy than a relay and pure WSN. In addition, the simulation shows that the interference is highly affected the relay and pure WSN communication. Thus, the proposed CoZNET helps in controlling the unnecessary energy consumption of the smart home devices.

The average and maximum packet failure rate among G_1 , G_2 , G_3 , and G_4 is computed and compared with the relay based WSN and pure WSN as shown in Figures 7 (a) and (b), respectively.

The packet failure rate in pure and relay based WSN is measured by calculating the number of failed packets divided by the total number of packets under different WLAN scenarios. The group of sensors that is present near to the WIFI AP i.e. G_1 , has a relatively high interference than the rest of the groups. The simulation reveals that as the physical distance between the sensors and WIFI AP increases, the interference level decreases. However, in the case of the pure WSN and relay based WSN, the packet loss rate is high than the proposed CoZNET scheme. The division of channels among the group of sensors helps the sensors to connect to a particular channel set. Consequently, it significantly reduces the probability of interference. Thus, the CoZNET is an accurate solution for reducing the effect of radio interference in a smart home scenario. Moreover, the proposed smart home control

system can help in placing the WSN nodes in appropriate locations that further helps in efficient communication with the SMCS system.

VI. CONCLUSION

The coexistence of heterogeneous networks and energy efficiency in the smart home environment stand front among the multiple challenges in the realization of HEMS. This paper presented an architecture of energy and interference aware smart home design. The proposed smart home system employed a CoZNET mechanism to mitigate the effect of interference caused due to the co-existence of WSN and WIFI networks. A light control system is developed to use natural light with the light source to reduce the energy consumption of the light source. The proposed smart home architecture is tested for both energy consumption by the devices and the interference caused due to the co-existence of WIFI and WSN networks. The simulation results revealed that the proposed CoZNET mechanism is significantly less affected by the interference. Moreover, the household appliances in the smart home required less energy comparing to the pure WSN and relay based WSN.

REFERENCES

- [1] J.-Y. Son, J.-H. Park, K.-D. Moon, and Y.-H. Lee, "Resource-aware smart home management system by constructing resource relation graph," *IEEE Trans. Consum. Electron.*, vol. 57, no. 3, pp. 1112–1119, Aug. 2011.
- [2] M. Zamora-Izquierdo, J. Santa, and A. Gomez-Skarmeta, "An integral and networked home automation solution for indoor ambient intelligence," *IEEE Pervasive Comput.*, vol. 9, no. 4, pp. 66–77, Oct./Dec. 2011.
- [3] S. Ahmed and D. Kim, "Named data networking-based smart home," *ICT Exp.*, vol. 2, no. 3, pp. 130–134, 2016.
- [4] S. Ahmed, D. Kim, S. Bouk, and N. Javaid, "Error control based energy minimization for cooperative communication in WSN," *SIGAPP Appl. Comput. Rev.*, vol. 14, no. 3, pp. 55–64, 2014.
- [5] Y. Zhao, W. Sheng, J. Sun, and W. Shi, "Research and thinking of friendly smart home energy system based on smart power," in *Proc. Int. Conf. Electr. Control Eng. (ICECE)*, Yichang, China, 2011, pp. 4649–4654.
- [6] L. Li, H. Xiaoguang, C. Ke, and H. Ketai, "The applications of WiFi-based wireless sensor network in Internet of things and smart grid," in *Proc. 6th IEEE Conf. Ind. Electron. Appl. (ICIEA)*, Beijing, China, 2011, pp. 789–793.
- [7] A. N. Alvi, S. H. Bouk, S. H. Ahmed, M. A. Yaqub, M. Sarkar, and H. Song, "BEST-MAC: Bitmap-assisted efficient and scalable TDMA-based WSN MAC protocol for smart cities," *IEEE Access*, vol. 4, pp. 312–322, Jan. 2016.
- [8] D.-M. Han and J.-H. Lim, "Smart home energy management system using IEEE 802.15.4 and ZigBee," *IEEE Trans. Consum. Electron.*, vol. 56, no. 3, pp. 1403–1410, Aug. 2010.
- [9] P. Vlacheas et al., "Enabling smart cities through a cognitive management framework for the Internet of things," *IEEE Commun. Mag.*, vol. 51, no. 6, pp. 102–111, Jun. 2013.
- [10] L. Liu, Y. Liu, L. Wang, A. Zomaya, and S. Hu, "Economic and balanced energy usage in the smart home infrastructure: A tutorial and new results," *IEEE Trans. Emerg. Topics Comput.*, vol. 3, no. 4, pp. 556–570, Dec. 2015.
- [11] S. Rani, R. Talwar, J. Malhotra, S. Ahmed, M. Sarkar, and H. Song, "A novel scheme for an energy-efficient Internet of things based on wireless sensor networks," *Sensors*, vol. 15, no. 11, pp. 28603–28626, 2015.
- [12] J. Han, C. S. Choi, W. K. Park, I. Lee, and S. H. Kim, "Smart home energy management system including renewable energy based on ZigBee and PLC," *IEEE Trans. Consum. Electron.*, vol. 60, no. 2, pp. 198–202, May 2014.
- [13] O. Elma and U. S. Selamogullari, "A new home energy management algorithm with voltage control in a smart home environment," *Energy*, vol. 91, pp. 720–731, Nov. 2015.
- [14] E. Shirazi, A. Zakariazadeh, and S. Jadid, "Optimal joint scheduling of electrical and thermal appliances in a smart home environment," *Energy Convers. Manage.*, vol. 106, pp. 181–193, Dec. 2015.
- [15] Apple. (Jun. 2016). *Working With HomeKit*. [Online]. Available: <https://developer.apple.com/homekit/>.
- [16] E. E. Room. (Mar. 22, 2016). *Wireless Indoor Sensor With Apple HomeKit Technology*. [Online]. Available: <http://www.amazon.com/Elgato-Wireless-Indoor-HomeKit-technology/dp/B00YHKL6A>
- [17] Qualcomm. (Mar. 22, 2016). *QI (Quite Interesting) Everything*. [Online]. Available: <https://www.qualcomm.com/internet-of-everything/>
- [18] S. Rani and S. Ahmed, *Multi-hop Routing in Wireless Sensor Networks: An Overview, Taxonomy, and Research Challenges*. New York, NY, USA: Springer, 2016.
- [19] S. Y. Shin, H. S. Park, S. Choi, and W. H. Kwon, "Packet error rate analysis of ZigBee under WLAN and bluetooth interferences," *IEEE Trans. Wireless Commun.*, vol. 6, no. 8, pp. 2825–2830, Aug. 2007.
- [20] T. Du, Z. Wang, D. Makrakis, and H. T. Mouftah, "Protective dummy-byte preamble padding for improving ZigBee packet transmission under Wi-Fi interference," in *Proc. WCNC*, New Orleans, LA, USA, 2015, pp. 1918–1923.
- [21] F. A. Qayyum, M. Naeem, A. S. Khwaja, A. Anpalagan, L. Guan, and B. Venkatesh, "Appliance scheduling optimization in smart home networks," *IEEE Access*, vol. 3, pp. 2176–2190, Oct. 2015.
- [22] A. Agnetis, G. De Pascale, P. Detti, and A. Vicino, "Load scheduling for household energy consumption optimization," *IEEE Trans. Smart Grid*, vol. 4, no. 4, pp. 2364–2373, Dec. 2013.
- [23] M. Pipattanasomporn, M. Kuzlu, and S. Rahman, "An algorithm for intelligent home energy management and demand response analysis," *IEEE Trans. Smart Grid*, vol. 3, no. 4, pp. 2166–2173, Dec. 2012.
- [24] S. H. Hong, M. Yu, and X. Huang, "A real-time demand response algorithm for heterogeneous devices in buildings and homes," *Energy*, vol. 80, pp. 123–132, Feb. 2015.



MURAD KHAN received the B.S. degree in computer science from the University of Peshawar, Pakistan, in 2008. He is currently pursuing the Ph.D. degree with the School of Computer Science and Engineering, Kyungpook National University, Daegu, South Korea.

His area of expertise includes ad hoc and wireless networks, architecture designing for Internet of Things, and communication protocols.



BHAGYA NATHALI SILVA received the B.S. and M.S. degrees in information technology from the Sri Lanka Institute of Information Technology, Colombo, in 2011. She is currently pursuing the degree with the School of Computer Science and Engineering, Kyungpook National University, Daegu, South Korea.

Her area of expertise includes architecture designing for Internet of Things, machine-to-machine communication, cyber physical systems, and communication protocols.



KIJUN HAN received the B.S. degree in electrical engineering from Seoul National University, South Korea, in 1979, the M.S. degree in electrical engineering from KAIST, South Korea, in 1981, and the M.S. and Ph.D. degrees in computer engineering from the University of Arizona, in 1985 and 1987, respectively.

He has been a Professor with the School of Computer Science and Engineering, Kyungpook National University, South Korea, since 1988.

• • •