

Received February 27, 2015, accepted March 27, 2015, date of publication April 10, 2015, date of current version April 28, 2015.

Digital Object Identifier 10.1109/ACCESS.2015.2421517

An Efficient MAC Protocol With Adaptive Energy Harvesting for Machine-to-Machine Networks

YI LIU¹, ZUYUAN YANG^{1,2}, (Member, IEEE), RONG YU¹, (Member, IEEE),
YONG XIANG², (Senior Member, IEEE), AND SHENGLI XIE¹, (Senior Member, IEEE)

¹School of Automation, Guangdong University of Technology, Guangzhou 510006, China

²School of Information Technology, Deakin University, Melbourne Burwood Campus, Melbourne, VIC 3125, Australia

Corresponding author: Z. Yang (yangzuyuan@aliyun.com)

This work was supported in part by the High Education Excellent Young Teacher Program of Guangdong Province under Grant YQ2013057, in part by the Science and Technology Program of Guangzhou under Grant 2014J2200097 through the Zhujiang New Star Program, in part by the Program for New Century Excellent Talents in University under Grant NCET-13-0740, in part by the Guangdong Natural Science Funds for Distinguished Young Scholar under Grant 2014A030306037, in part by the National Natural Science Foundation of China under Grant 61273192, Grant 61333013, Grant 61370159, Grant 61403086, Grant 61422201, and Grant U1201253, and in part by the Guangdong Province Natural Science Foundation under Grant S2011030002886.

ABSTRACT In a machine-to-machine network, the throughput performance plays a very important role. Recently, an attractive energy harvesting technology has shown great potential to the improvement of the network throughput, as it can provide consistent energy for wireless devices to transmit data. Motivated by that, an efficient energy harvesting-based medium access control (MAC) protocol is designed in this paper. In this protocol, different devices first harvest energy adaptively and then contend the transmission opportunities with energy level related priorities. Then, a new model is proposed to obtain the optimal throughput of the network, together with the corresponding hybrid differential evolution algorithm, where the involved variables are energy-harvesting time, contending time, and contending probability. Analytical and simulation results show that the network based on the proposed MAC protocol has greater throughput than that of the traditional methods. In addition, as expected, our scheme has less transmission delay, further enhancing its superiority.

INDEX TERMS Machine-to-machine network, adaptive energy harvesting, medium access control.

I. INTRODUCTION

Machine-to-machine (M2M) communication technology has been deemed as one of the next promising technologies in networking, as it has the potential to connect billions of trillions of machine-type devices to provide automatic and persistent wireless services [1], [2]. Under the M2M communication scheme, there may exist tremendous numbers of devices to communicate with the base stations (BSs) concurrently and continually. To promote the throughput of the whole M2M network, two issues should be considered seriously: 1) massive access control, which is vital in providing a simultaneous communication for enormous numbers of devices and BSs; 2) continuous energy supply, which is critical for battery-driven wireless devices and systems to work efficiently [3]–[5].

Regarding massive access control, 3GPP LTE launches several work items about M2M communications, concerning overload control [6], [7]. Also, an enhanced standard IEEE 802.16p is developed to support M2M applications, providing better massive access control than traditional

IEEE 802.16m standard [8], [9]. Considering that the massive access management of M2M communication over wireless channels generally happens at the medium access control (MAC) layer, we shall focus on the design of the MAC protocol. In the traditional MAC protocols, the contention based random access (RA) schemes are often utilized, where all of the devices are allowed to freely contend the transmission opportunities [10]–[12]. Clearly, the contention scheme is beneficial for improving the throughput of the whole network.

Now, let us have a look at the energy supply aspect under the MAC protocol. The existing methods/protocols mainly focus on how to save energy to prolong the data transmission in the M2M networks, where the energy is assumed to be fixed in prior. For example, in order to lower uplink energy consumption in M2M communication, the grouping and coordinator selection method is utilized in [5]. In [13], a hybrid MAC protocol is designed, where the devices are assigned to contend the transmission opportunities, and those failed in contention will turn to the sleep mode.

Such arrangement keeps the wake-up time of a device to be minimal, and can save abundant amount of energy. In [2], the authors focus on energy-efficiency challenges in the cognitive M2M for smart grid communications. A machine coordination is proposed for spectrum discovery, where machines with better sensing ability may cooperate with each other to reduce energy consumption during the spectrum discovery phase.

Taking into account of the energy supply problem in M2M network, a recently developed technology, called energy-harvesting, has attracted considerable attentions [14], [15]. By using energy harvesting, wireless networks could potentially have unlimited and green energy, supplied by renewable energy sources, such as solar, wind, thermal, acoustic, etc. This motivates us to promote the throughput of the M2M network by employing the energy-harvesting technology, instead of the existing fixed-energy methods. Since harvesting energy takes time, it will reduce the subsequent data transmission time. Thus, it is important to design proper methods to balance the requirements of energy harvesting and high-throughput data transmission.

In this paper, an efficient MAC protocol with adaptive energy-harvesting is proposed for the M2M network, which contains three processes: the energy harvesting process, the contending process, and the transmission process. In this protocol, different devices firstly harvest energy and then contend the transmission opportunities with different contending priorities which are related to their energy level. The devices with lower energy level after energy harvesting will be assigned higher contending probabilities. The parameters (or variables) related to energy harvesting and contending are obtained by solving a new model about the throughput of the network. After contention, only the successful devices are allowed to transmit data in the next transmission period. Compared with existing methods, the adaptive energy-harvesting based scheme shows greater potential to increasing the throughput of the M2M network, as it can better balance the time used for data transmission and energy harvesting.

The contributions of this paper are summarized as follows:

- An efficient MAC protocol incorporating with p -persistent CSMA mechanism is designed for energy harvesting M2M networks.
- By giving different contending priorities, the proposed MAC protocol allows devices with different energy harvesting abilities to obtain hierarchical transmission probabilities.
- To maximize the network throughput, an optimization problem is formulated to obtain the optimal contending probabilities, duration of energy harvesting period and contending period, respectively.

The remainder of the paper is organized as follows. In Section II, we describe the system model. The proposed MAC protocol design is presented in Section III. Section IV shows the analysis and maximization of average throughput. Simulation results are given in Section V, followed by concluding remarks in Section VI.

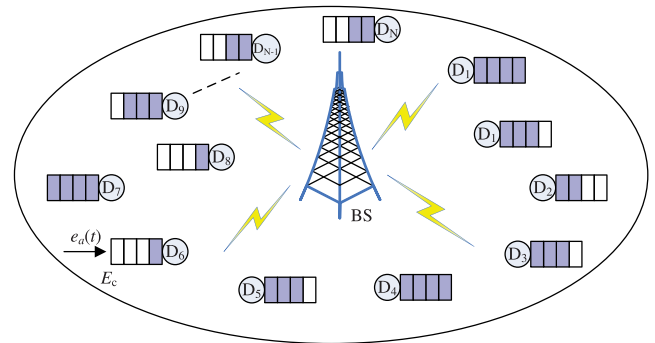

FIGURE 1. System model of M2M network.

II. SYSTEMS MODEL

A. M2M NETWORK MODEL

In this paper, we consider an energy harvesting M2M network consisting of one BS and N devices $\{D_1, \dots, D_N\}$, as shown in Fig. 1. The BS is supplied by traditional grid and responsible for operating medium access control for different active devices (the devices that have packet to transmit). The active devices are assigned different contending probabilities $\{p_q, q = 1, \dots, Q\}$ according to their energy amount and whether they have data packet to transmit. The energy amount is classified by pre-set energy ranges which are defined as $\{[E_1, E_2], \dots, [E_Q, E_{Q+1}]\}$, where the value of $\{E_q, q = 1, \dots, Q\}$ are predefined. Without loss of generality, we assume $E_1 < E_2 < \dots < E_{Q+1}$. In addition, the contending probabilities have the following relationship

$$p_q = \max\{1, (1 + \alpha)^{q-1} p_{inl}\}, \quad 0 \leq p_1 = p_{inl} \leq 1 \quad (1)$$

where α and p_{inl} denote the incremental indicator and the initial contending probability, respectively.

For each active device, the data packet arrival process is modeled as a Poisson arrival process with packet arrival rate λ_d . Here, for simplicity, we assume all devices have the same packet arrival rate which is known by BS. A new packet that arrives at a device is buffered until the device successfully contends the transmission opportunity and transmits the data packet. If a new packet arrives at the device before the transmission, the buffered packet will be replaced by the new one. Hence, there is one packet at most in the buffer of each device. Moreover, in order to maintain stationary property, we assume that all devices in the network are static (i.e., we do not consider mobility effects).

B. ENERGY MODEL

Suppose that each device equipped with an energy harvester which is able to convert ambient energy (e.g., solar, wind, thermal, vibration, and even ambient radio power) into electricity. Such electricity is first stored in a rechargeable battery of finite capacity E_c . Considering the rechargeable batteries cannot charge and discharge simultaneously, we assume that the devices need to cease the

energy harvesting before transmission. Then, the devices will consume the stored electricity for contention or transmission. For each device, the energy arrival process $\{e^H(t), t = 1, 2, \dots\}$ is modeled as an independent and identically distributed (i.i.d.) sequence of random variables with mean $\mathbb{E}[e^H(t)] = \bar{e}^H$. The energy arrival process is assumed to be independent of the data arrival process at each device and the primary users' activities.

At the beginning of a time slot, a device may make the decision of being active or sleep depending on whether there is a data packet arrival or not. If the sleep mode is selected, the SU will turn off its transceiver until the next slot. We assume that the energy amount consumed in this mode can be ignored. If the active model is chosen, the SU will start the harvesting-contending-transmission process. In this process, the device firstly harvests the energy during energy harvesting period and the harvested energy is $E^H = T^H \bar{e}^H$, where T^H is the length of the energy harvesting period. After that, the device consumes the contending energy, denoted by $E^C = T^C \mathcal{P}_r$, where T^C is the length of the contending period and \mathcal{P}_r is the transmitting power, in contention. In transmission phase, the device consumes the transmission energy, denoted by $E^R = T^R \mathcal{P}_r$, where T^R is the transmission time.

III. DESIGN OF ENERGY EFFICIENT MAC PROTOCOL

In this section, we present the specifications of the proposed MAC protocol with energy harvesting heterogeneity.

A. OVERVIEW

In Fig. 2, we show the time frame of series operations of devices and BS in the proposed MAC protocol. The whole frame is divided into four parts: notification period, harvesting period, contention period and transmission period. During notification period, the BS broadcasts notification message to all devices for notifying the beginning of a frame. Then, during the harvesting period, the active devices will turn on the energy harvesting module to harvest energy. After that, the BS starts the contention period. In contention period, devices randomly send the transmission request to BS based on

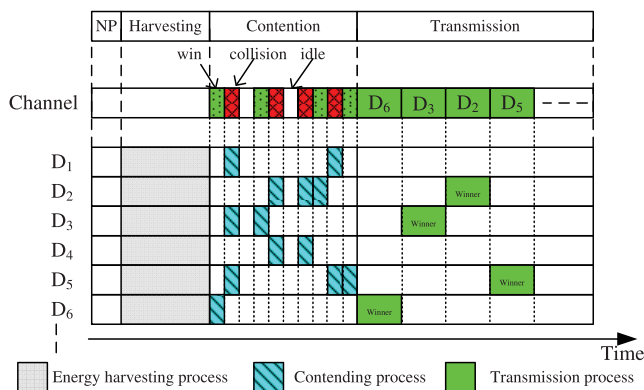

FIGURE 2. The work flow of the proposed MAC protocol.

p -persistent CSMA access method [16]. The devices succeeded in contention are allowed to transmit data packet in the following transmission period which provides a TDMA type of communication for the devices. We assume that each assigned transmission slot has the same length and there is no transmission error for each device [5], [13]. More detailed description of the MAC protocol design is given in the next subsection.

B. MAC PROTOCOL DESIGN

1) NOTIFICATION PERIOD (NP)

At the start of each frame, the BS broadcasts a notification message to all N devices to start a frame and inform the active devices' identification (ID). Upon receiving the notification message, the active devices prepare to harvest energy and contend the transmission time slots. Other devices that do not have packets to send will enter sleep mode to preserve energy. The notification message includes information about the length of energy harvesting period, contending period and contending probabilities of each device. Then, the M2M network enters to energy harvesting period.

2) HARVESTING PERIOD (HP)

At the beginning of HP, the active devices turn on energy harvesting mode and start to harvest energy from surrounding environment. They firstly store the harvested energy in the battery and then use the stored energy for contention and transmission. Meanwhile, the devices report the amount of the harvested energy to BS. At the end of HP, the devices cease the energy harvesting process and prepare the contending process.

3) CONTENTION PERIOD (CP)

In this period, the operations of the devices and BS are as follows:

Devices: The devices contend the transmission opportunities based on p -persistent CSMA mechanism. In each subplot of the contention period, the active devices send the transmission request (Tran-REQ) message to the BS, according to their own contending probability p . The contention is declared as success only when one device sends the Tran-REQ message. When more than one devices are sending Tran-REQ during the same time interval, a collision occurs. The idle period is a time interval in which the contention is not happening. Upon receiving the ACK message from BS, the device will stop sending Tran-REQ message and waits for the next period. In addition, the ACK message includes the index of the transmission time slot of the device which is allowed to transmit in transmission period.

BS: If a Tran-REQ message from a device is successfully received, the BS sends ACK message and the index of a transmission time slot to this device. Meanwhile, the BS records the number of the successful devices. Once such number is greater than the theoretical optimal number of successful devices or the timer exceeds theoretical optimal duration

of CP, the BS will stop the CP and declare the beginning of next period, i.e., transmission period. The calculation of optimal number of successful devices and optimal duration of CP will be shown in Section IV.

4) TRANSMISSION PERIOD (TP)

In TP, the devices that failed in contention cease their contending operations and turn to sleep mode. Other devices succeeded in contention sequentially operate the transmission following the TDMA mechanism. These devices turn on their transmitters and transmit the data packet during their own transmission time slots. When the transmission is finished, the devices report the residual amount of energy to BS and turn off the radio module at other time slots. When the timer of TP is out, the BS declares the beginning of a new frame.

Discussion: To maximize the throughput of the M2M network, it is expected that more energy and transmission opportunities can be harvested if NP and CP become longer [17], [18]. However, given the fixed duration of a frame, increasing NP and CP will lead to the decrease of TP. Thus, the transmission time for the active devices will be reduced. Hence, there is a tradeoff among the durations of NP, CP and TP. To maximize the throughput, it is necessary to control the devices' access behaviors according to the optimal lengths of NP and CP as well as the contending probability for each device.

IV. PERFORMANCE ANALYSIS

In this section, we will analyze and optimize the average throughput by considering the tradeoff among the lengths of NP, CP and TP. Given the length of TP, our goal is to find four design parameters: the optimal lengths of NP and CP, the initial contending probability p_{inl} and incremental indicator α . A hybrid differential evolution algorithm is developed to solve the proposed optimization problem.

A. THROUGHPUT DERIVATION

Denote $C_{i,m}$ and $b_{i,m}$ to be the data rate and the transmission time slot of device m at frame i , respectively. Then, the average throughput of the network over I frames can be expressed as [19]:

$$U = \frac{1}{I} \sum_{i=1}^I \sum_{m=1}^{\mathcal{M}_i} C_{i,m} b_{i,m} \quad (2)$$

where \mathcal{M}_i denotes the number of the devices which have opportunities to transmit data during TP at frame i . Practically, it is often assumed that the values of $b_{i,m}, \forall i, m$ are the same, denoted by b without loss of generality, and $C_{i,m}$ can be calculated by [19]:

$$C_{i,m} = \log_2 \left(1 + \frac{h(E_{m,i-1}^R + E_{m,i}^H - E_{m,i}^C)}{\delta b} \right) \quad (3)$$

where $h, \delta, E_{m,i-1}^R, E_{m,i}^H$ and $E_{m,i}^C$ denote channel gain, noise power, residual energy, harvested energy, and the contending energy of device m at frame i , respectively. For simplicity,

we make the assumption that the three items $E_{m,i-1}^R, E_{m,i}^H$ and $E_{m,i}^C$ remain the same when m changes, and thus will remove the index m accordingly. Then, (2) can be rewritten as:

$$U = \frac{1}{I} \sum_{i=1}^I \sum_{m=1}^{\mathcal{M}_i} b \log_2 \left(\frac{\delta b + h(E_{m,i-1}^R + E_{m,i}^H - E_{m,i}^C)}{\delta b} \right) \\ = \frac{1}{I} \sum_{i=1}^I \mathcal{M}_i b \log_2 \left(\frac{\delta b + h(E_{i-1}^R + E_i^H - E_i^C)}{\delta b} \right). \quad (4)$$

In (4), the parameters I, b, δ, h are pre-set and known. As shown later, \mathcal{M}_i is related to the variables about time. For consistence, the energy variables will also be replaced by the corresponding time variables. Actually, in our protocol, it satisfies that

$$\begin{cases} E_i^H = T_i^H \mathcal{P}_r \\ E_i^C = T_i^C \mathcal{P}_r \\ E_i^R = E_{i-1}^R + E_i^H - E_i^C - E_i^T \end{cases} \quad (5)$$

where T_i^H and T_i^C denote periods of the energy harvesting and contention at frame i , respectively, $E_i^T = b \mathcal{P}_r$, and \mathcal{P}_r denotes the transmission power and it is known in prior.

Now, let us turn to \mathcal{M}_i . This variable is mainly affected by two factors. One is the number of the devices succeeded in contention at frame i , denoted by M_i^C . The other is the total number of the transmission devices allowed by the network. In this paper, \mathcal{M}_i is calculated by

$$\mathcal{M}_i = \min \left\{ M_i^C, \left\lfloor \frac{T_i - T_i^N - T_i^H - T_i^C}{b} \right\rfloor \right\} \quad (6)$$

where T_i and T_i^N denote the durations of frame and notification, respectively, and they are known in prior. M_i^C can be calculated by

$$M_i^C = \sum_{q=1}^Q [M_{q,i} P(\text{Success}_q^i)] \quad (7)$$

where $M_{q,i}$ is the number of the type q devices at frame i and Q denotes the pre-set total device types. $P(\text{Success}_q^i)$ denotes the probability that a type q device succeeded in contention at frame i , and it is controlled by T_i^H and $M_{q,i}$. The detailed derivation of $P(\text{Success}_q^i)$ is shown in Appendix A.

Based on the analysis above, to calculate (4), one needs only to explore $M_{q,i}, T_i^H, T_i^C$, where $M_{q,i}, T_i^H$ are explicit and will be optimized directly. As for T_i^C , it will be further analyzed, based on the p -persistent CSMA where devices have prioritized contending probabilities [16].

Following the p -persistent CSMA method, the contending period contains two parts: the unity contending subperiod and the contending delay. Let a and $\mathbb{E}[R_i^j]$ be the unity length of a contending subperiod and the average contending delay between the $(j-1)$ th and the j th successful contentions at frame i , respectively. Then, T_i^C can be decomposed by

$$T_i^C = \sum_{j=1}^{M_i^C} (\mathbb{E}[R_i^j] + a) \quad (8)$$

where a is a pre-set constant. For simplicity, we assume that $\mathbb{E}[R_i^j]$ keeps the same for all j . Then, (8) is rewritten as

$$T_i^C = M_i^C (\mathbb{E}[R_i] + a). \quad (9)$$

Based on [20], the involved $\mathbb{E}[R_i], \forall i$ can be further decomposed by

$$\mathbb{E}[R_i] = a \sum_{g=1}^G P(R_i \geq ga) \quad (10)$$

where $G \in \{1, \dots, \lfloor T_i/a \rfloor\}$ is chosen randomly, and $P(R_i \geq ga)$ denotes the probability that the contending subperiod length has at least g time slots at frame i .

To calculate the probability $P(R_i \geq ga)$, we will introduce four important probabilities. The first one is the probability that the energy of a device after harvesting belongs to the energy range $\{[E_{q-1}, E_q], q = 1, \dots, Q\}$ at frame i , and we denote this probability by $\beta_{q,i}$. It is known that the energy arrival process has Poisson distribution in the network and the current energy of a device consists of the residual energy from last frame and the harvested energy in current frame. Then, denoting the energy arrival rate to be λ_e , we can obtain $\beta_{q,i}$ by

$$\beta_{q,i} = e^{-T_i^H \lambda_e E_{q-1}} - e^{-T_i^H \lambda_e E_q} \quad (11)$$

where E_q is pre-set and known.

Considering that the data packet arrival process is also of a Poisson distribution [21], [22], the second probability is introduced as

$$\gamma_{q,i} = \beta_{q,i} \eta_i \quad (12)$$

where $\eta_i = 1 - e^{-\lambda_d T_i}$ denotes the probability that a device has at least one new packet arrival during T_i , and λ_d denotes the packet arrival rate at each device. This probability reflexes how a type q device will join the contention at frame i .

The third one is the probability that the transmission delay is at least g time slots in a contending subperiod when only considering type q traffic at frame i , and it is labeled as $P(R_{q,i} \geq ga)$. The fourth one represents the probability that the transmission delay is at least g time slots and no arrivals occurred in a contending subperiod when only considering type q traffic at frame i . This probability is symbolized as $P(R_{q,i}^0 \geq ga)$.

Next we will derive the explicit expressions of the third probability $P(R_{q,i} \geq ga)$ and the fourth probability $P(R_{q,i}^0 \geq ga)$. Let $L_{q,i}^0$ be the number of type q devices that will join the contending at a contending subperiod at frame i . Then, the probability that $L_{q,i}^0$ equals n is [20]:

$$P(L_{q,i}^0 = n) = \binom{M_{q,i}}{n} \gamma_{q,i}^n (1 - \gamma_{q,i})^{(M_{q,i} - n)}. \quad (13)$$

Also, denote $L_{q,i}^s$ to be the number of non-empty type q devices when $R_{q,i} = ga$ at frame i . Given $L_{q,i}^0 = n$, the

conditional probability that $R_{q,i} \geq ga$ and $L_{q,i}^s = n + m$ is

$$\begin{aligned} P(R_{q,i} \geq ga, L_{q,i}^s = n + m | L_{q,i}^0 = n) \\ = (1 - p_{q,i})^{gn} (1 - \gamma_{q,i})^{g(M_{q,i} - n)} \binom{M_{q,i} - n}{m} \\ \cdot \left(\frac{\gamma_{q,i}}{p_{q,i} - \gamma_{q,i}} \right) \left[1 - \left(\frac{1 - p_{q,i}}{1 - \gamma_{q,i}} \right)^g \right]^m \end{aligned} \quad (14)$$

where $p_{q,i}$ denotes the contention probability of the type q device at frame i .

Similar to the method in [20], by evaluating (14) over the full range of possible values of m , we have

$$\begin{aligned} P(R_{q,i} \geq ga | L_{q,i}^0 = n) \\ = (1 - p_{q,i})^{gn} \left[\frac{p_{q,i}(1 - \gamma_{q,i})^g - \gamma_{q,i}(1 - p_{q,i})^g}{p_{q,i} - \gamma_{q,i}} \right]^{M_{q,i} - n}. \end{aligned} \quad (15)$$

Combining (13) with (15), we can get the following total probability by evaluating over the range of possible values for $L_{q,i}^0$:

$$\begin{aligned} P(R_{q,i} \geq ga) \\ = \sum_{n=0}^{M_{q,i}} P(R_{q,i} \geq ga | L_{q,i}^0 = n) \times P(L_{q,i}^0 = n) \\ = \left[(1 - p_{q,i})^g - (1 - \gamma_{q,i}) p_q \frac{(1 - p_{q,i})^g - (1 - \gamma_{q,i})^g}{p_{q,i} - \gamma_{q,i}} \right]^{M_{q,i}}. \end{aligned} \quad (16)$$

Similarly, the total probability about $L_{q,i}^0$ can be calculated by:

$$\begin{aligned} P(R_{q,i}^0 \geq ga) \\ = P(R_{q,i}^0 \geq ga | L_{q,i}^0 = 0) \times P(L_{q,i}^0 = 0) \\ = \left[(1 - \gamma_{q,i}) \frac{p_{q,i}(1 - \gamma_{q,i})^g - \gamma_{q,i}(1 - p_{q,i})^g}{p_{q,i} - \gamma_{q,i}} \right]^{M_{q,i} - n}. \end{aligned} \quad (17)$$

Up to this point, we have obtained the expressions of all four introduced probabilities, which are shown in (11), (12), (16), and (17), respectively. Then, by using the probability decomposition scheme in [23], $P(R_i \geq ga)$ in (10) can be calculated by

$$P(R_i \geq ga) = \frac{\prod_{q=1}^Q P(R_{q,i} \geq ga) - \prod_{q=1}^Q P(R_{q,i}^0 \geq ga)}{1 - \prod_{q=1}^Q (1 - \gamma_{q,i})^{M_{q,i}}} \quad (18)$$

where the term $\prod_{q=1}^Q P(R_{q,i} \geq ga)$ shows that for $R_i \geq ga$ all devices of all traffic types must defer by at least g time slots, the term $\prod_{q=1}^Q P(R_{q,i}^0 \geq ga)$ removes the probability of $R_i \geq ga$ when $L_{q,i}^0 = 0$, and the term $1 / (1 - \prod_{q=1}^Q (1 - \gamma_{q,i})^{M_{q,i}})$ adds the condition that a busy subperiod will occur (they are all at frame i).

Finally, substitute (18) into (10), $\mathbb{E}[R_i]$ in (9) can be calculated by

$$\begin{aligned} \mathbb{E}[R_i] &= a \sum_{g=1}^G P(R_i \geq ga) \\ &= \frac{a \sum_{g=1}^G \left(\prod_{q=1}^Q P(R_{q,i} \geq ga) - \prod_{q=1}^Q P(R_{q,i}^0 \geq ga) \right)}{1 - \prod_{q=1}^Q (1 - \gamma_{q,i})^{M_{q,i}}} \end{aligned} \quad (19)$$

Combining with (4)-(9) and (19), one can conclude that the throughput in (4) is affected by the variables T_i^H , $p_{q,i}$, $M_{q,i}$, and an optimization problem about them will be constructed to calculate the throughput in the next subsection.

B. PROBLEM FORMULATION AND SOLUTION

Given the duration of frame i (T_i), longer energy harvesting period (T_i^H) provides bigger chance to obtain more energy which leads to higher throughput. Meanwhile, longer contending period (T_i^C) allows more devices to contend and obtain transmission opportunities which also can increase the system throughput. However, the incremental T_i^H and T_i^C will reduce the duration of transmission duration subjecting to the constraint as $T_i^H + T_i^C + M_i b \leq T_i$. To balance this tradeoff, we formulate an optimization problem to maximize the average throughput as follows

$$\max U = \frac{1}{I} \sum_{i=1}^I M_i b \log_2 \left(\frac{\delta b + h(E_{i-1}^R + T_i^H \mathcal{P}_r - T_i^C \mathcal{P}_r)}{\delta b} \right) \quad (20)$$

$$s.t. \begin{cases} T_i^C + T_i^H + M_i b \leq T_i \\ M_i = \min \left\{ M_i^C, \left\lfloor \frac{T_i - T_i^N - T_i^H - T_i^C}{b} \right\rfloor \right\} \\ M_i^C = \sum_{q=1}^Q [M_{q,i} P(\text{Success}_q^i)] \\ p_{q,i} = \max\{1, (1 + \alpha)^{q-1} p_{inl}\} \\ 0 < p_{inl} \leq 1, \alpha > 0 \\ \forall i \in \{1, \dots, I\}, \forall q \in \{1, \dots, Q\}. \end{cases}$$

In the model above, I , b , h , δ , \mathcal{P}_r , T_i , T_i^N , Q are pre-set and known, T_i^C is controlled by $p_{q,i}$, T_i^H , $M_{q,i}$ and $P(\text{Success}_q^i)$ is decided by T_i^H , $M_{q,i}$. In addition, E_i^R is calculated by $E_i^R = E_{i-1}^R + T_i^H \mathcal{P}_r - T_i^C \mathcal{P}_r - b \mathcal{P}_r$ iteratively. The optimization problem in (20) implies a mixed-integer non-linear programming problem which comprises integer or discrete variables in addition to continuous variables. It is difficult to use the existing linear programming tool to solve it. Hence, in this paper, we employ a hybrid differential evolution algorithm to solve the mixed-integer non-linear programming problem, which extends the different evolution algorithm to the problem. We also replace the constrained optimization problem with an unconstrained one, whose solutions ideally converge to that of the original problem, and define the penalty function as

$$\mathcal{F} = -U + \mu((T_i^C + T_i^H + M_i^C b - T_i)^+)^2 \quad (21)$$

where μ is the penalty factor (which iteratively increase) and $[x]^+ = \max\{x, 0\}$.

The hybrid differential evolution algorithm proposed for solving the optimization problem is summarized in Algorithm 1. Here, PS , MF and CC denote the population size, mutation factor and crossover constant, respectively. C_{tep} and C_{max} denote the iteration step and maximum number of iterations, respectively. $\epsilon = 10^{-10}$ is the improvement threshold in stopping criterion. At first, by randomly selecting PS vectors from $S = (T_i^H, M_{q,i}, \alpha, p_{inl})$, the evaluation function \mathcal{F} can be calculated. Then, if the minimum value of $\mathcal{F}(S) - OPT$ is greater than ϵ or the iteration step C_{tep} less than C_{max} , the new solution is accepted or rejected according to the evaluation process executed at Steps 06 to 15. Finally, at Steps 16 and 17, the algorithm records the optimal $\mathcal{F}(S)$ to the OPT and returns the optimal vector S^* .

Algorithm 1: Hybrid Differential Evolution Algorithm

```

01: Initiation:  $OPT = 0$ ,  $C_{tep} = 0$ ,  $C_{max} = 1000$ ,
 $PS = 30$ ,  $MF = 0.85$ ,  $CC = 0.7$ ,
 $\{S = (T_i^H, M_{q,i}, \alpha, p_{inl}), T_i^H \in [0, T_i],$ 
 $M_{q,i} \in [1, N], \alpha \in [0, \infty), p_{inl} \in [0, 1]\}$ ;
02: Randomly select  $PS$  vectors from  $S$ ;
03: While  $C_{tep} < C_{max}$  or
 $|\min\{\mathcal{F}(S_k), k = 1, \dots, PS\} - OPT| \geq \epsilon$  do;
04:  $C_{tep} \leftarrow C_{tep} + 1$ ;
05: for all  $k \in \{1, \dots, PS\}$  do;
06: Randomly select  $z$ ,  $x$ , and  $y \in \{1, \dots, PS\} - \{k\}$ ;
07:  $S_l \leftarrow S_y + \lfloor \mathcal{F}(S_y - S_z) \rfloor$ ;
08: Randomly select  $c_1 \in [0, 1]$ ;
09: If  $c_1 > CC$  then  $S_t \leftarrow S_k$ ;
10: else  $S_t \leftarrow S_l$ ;
11: end If;
12: If  $\mathcal{F}(S_t) < \mathcal{F}(S_k)$  then;
13:  $S_k \leftarrow S_t$ ;
14: end If;
15: end for;
16:  $OPT \leftarrow \min\{\mathcal{F}(S_k), k = 1, \dots, PS\}$ ;
17: end While;
18:  $S^* = \arg \min\{\mathcal{F}(S_k), k = 1, \dots, PS\}$ .

```

V. SIMULATION RESULTS

In this section, we demonstrate the performance of the proposed MAC protocol in M2M network by simulations. The new MAC protocol is also compared with the traditional RA protocol in which the winners start the transmission immediately after the devices randomly compete the transmission opportunities [10], and the recently developed hybrid MAC protocol in which the winners transmit the data during specific time slots after the whole contending period ends [13]. To measure the performance, we utilize the average throughput index given in (4), followed by the index of transmission delay which is defined as the averaged waiting frame number before one successful transmission is completed.

In the simulations, the important pre-set parameters for the compared algorithms are summarized in Table 1.

TABLE 1. Important pre-set parameters.

I	100	Number of the frames
$T_i^N(\forall i)$	$10 \mu s$	Duration of the notification
N	1000	Number of the devices
Q	10	Number of priority types
$T_i(\forall i)$	1000 ms	Duration of the i th frame
h	1	Channel gain
δ	0.5 mW	Noise power
b	2 ms	Transmission time of each device
T_{req}	$22.2 \mu s$	Length of Tran-REQ message
T_{ACK}	$7.5 \mu s$	Duration of ACK frame
P_r	3 mW	Transmission power of a device
\bar{e}^H	0.1 mJoule	Harvested energy per second

A. THROUGHPUT

Similar to [13], we test the case that the data packet arrival rate is $\lambda_d = 2$ firstly. Fig. 3 shows the throughput of proposed MAC protocol, with comparison to the hybrid MAC protocol and the RA protocol. It can be seen that the proposed MAC protocol is able to achieve much higher throughput than that of the hybrid MAC protocol and the RA protocol. The main reason is that the proposed MAC protocol employs the adaptive energy-harvesting technology, based on which the time costs of the data transmission and the energy-harvesting are better balanced, leading to the maximization of the throughput. On the contrary, the hybrid MAC protocol fixes the energy supply in prior, affecting the subsequent data transmission. As for the RA protocol, different from the hybrid MAC and our method, it utilizes a random contention method which may cause severe congestion in massive M2M network with numerous devices. As a result, the corresponding throughput is the lowest.

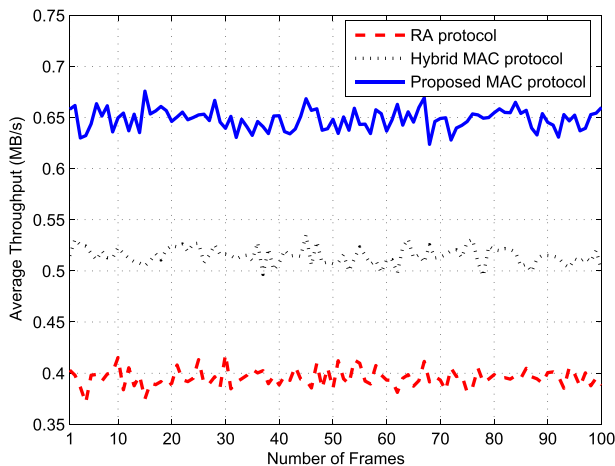

FIGURE 3. Average throughput with data packet arrival rate $\lambda_d = 2$.

We also compare the three methods under different λ_d . Without loss of generality, the results in the case

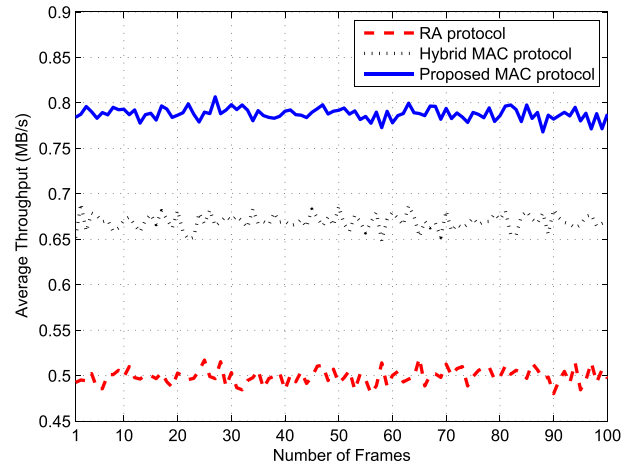

FIGURE 4. Average throughput with data packet arrival rate $\lambda_d = 4$.

of $\lambda_d = 4$ is given here. Fig. 4 shows the average throughput of each compared method with $\lambda_d = 4$. Clearly, the proposed MAC protocol outperforms the other two protocols. Interestingly, for each method, the throughput index is better than the case of $\lambda_d = 2$, providing one more choice (i.e., increasing the arrival rate of the data packet), to improve the throughput of the network.

B. TRANSMISSION DELAY

In this subsection, the transmission delays under different protocols are tested. And the corresponding indices are calculated with different energy packet arrival rates λ_e . Without loss of generality, the results of the first 100 frames in the cases of $\lambda_e = 2$ and $\lambda_e = 4$ are presented below.

Fig. 5 shows the transmission delays of the proposed MAC protocol, the hybrid MAC protocol and the RA protocol, respectively, where $\lambda_e = 2$. We can see that the proposed hybrid protocol yields the least transmission delay, among the compared methods. This is because our

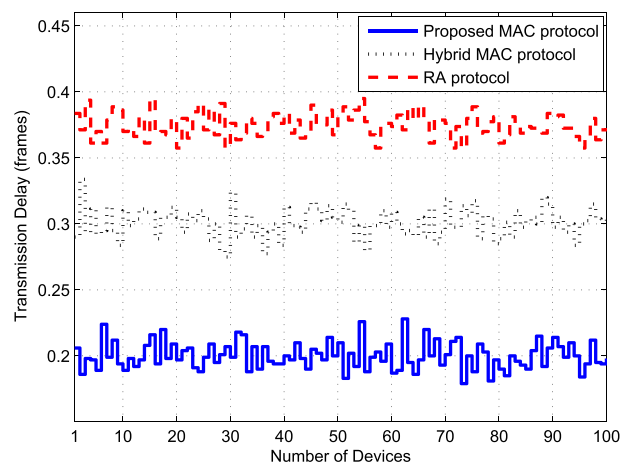

FIGURE 5. The transmission delay with energy packet arrival rate $\lambda_e = 2$.

method can optimally control the energy harvesting and contention periods to allow more devices have the transmission opportunities. In addition, since the devices with more energy can obtain higher opportunities to transmit data, the transmission rule for one particular device is also optimized, further reducing the transmission delay of the entire network.

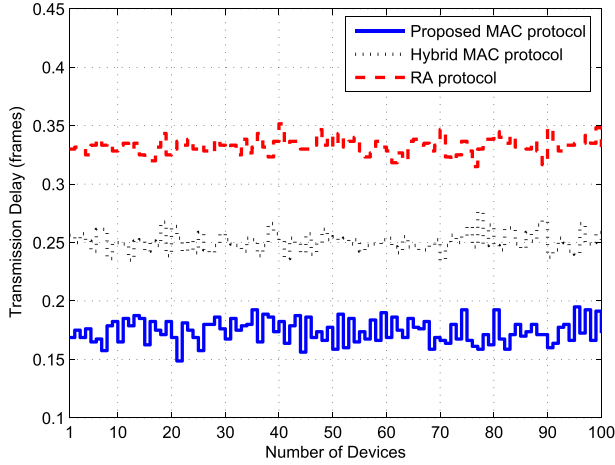

FIGURE 6. The transmission delay with energy packet arrival rate $\lambda_e = 4$.

Fig. 6 shows the transmission delays of the compared protocols with $\lambda_e = 4$. Again, one can see that the proposed MAC protocol has the lowest transmission delay. This is consistent with the results in the case of $\lambda_e = 2$. Moreover, the average transmission delay obtained in the case $\lambda_e = 4$ is lower than that in the case of $\lambda_e = 2$. The reason is simple, as higher energy arrival rate can make devices harvest more energy for transmission and this benefits the reduction of the transmission delay.

VI. CONCLUSION

In this paper, an adaptive energy-harvesting MAC protocol was designed and analyzed for massive M2M wireless networks. In the protocol, the device operation comprised three parts: energy harvesting, contending process, and transmission process. Under this protocol, a new model was proposed to obtain the optimal throughput for the M2M network. For solving this model, a hybrid differential evolution algorithm was also developed. Due to the optimization to the energy-harvesting, the contending, and the transmission, our protocol can achieve a high throughput with a low transmission delay for the entire network. Simulation results verified that the superior performance of the proposed MAC protocol over the compared methods.

APPENDIX A DERIVATION OF $P(\text{SUCCESS}_q^i)$

The probability $P(\text{SUCCESS}_q^i)$ is mainly decided by 1) the probability that only one type c contending occurs at a contending subperiod in frame i , denoted by $P(1ct_{c,i})$ and 2) the probability that no transmission occurs in a subperiod at frame i , denoted by $P(0tc_{q,i})$, $q \neq c$.

We start from the calculation of $P(1ct_{c,i})$ in 1). Let $p_{c,i}$, $\gamma_{c,i}$ and $M_{c,i}$ denote the contending probability, the probability of a type c device that will join the contention, and the number of type c devices at frame i , respectively. Then, given a time slot $g \in \{0, 1, 2, \dots, G\}$, $R_{c,i} \geq ga$, $L_{c,i}^g = n + m$, and $L_{c,i}^0 = n$, the conditional $P(1ct_{c,i})$ can be obtained by

$$P(1ct_{c,i} | R_{c,i} \geq ga, L_{c,i}^g = n + m, L_{c,i}^0 = n) = p_{c,i}(n + m)(1 - p_{c,i})^{n+m-1}. \quad (22)$$

After removing the conditions $R_{c,i} \geq ga$ and $L_{c,i}^g = n + m$ in (22), it yields

$$\begin{aligned} P(1ct_{c,i} | L_{c,i}^0 = n) &= \sum_{m=0}^{M_{c,i}-n} P(1ct_{c,i} | R_{c,i} \geq ga, L_{c,i}^g = n + m, L_{c,i}^0 = n) \\ &\quad \cdot P(R_{c,i} \geq ga, L_{c,i}^g = n + m | L_{c,i}^0 = n) \\ &= p_{c,i}n(1 - p_{c,i})^{(g+1)n-1} \\ &\quad \cdot \left(\frac{p_{c,i}(1 - \gamma_{c,i})^{g+1} - \gamma_{c,i}(1 - p_{c,i})^{g+1}}{p_{c,i} - \gamma_{c,i}} \right)^{M_{c,i}-n} \\ &\quad + \gamma_{c,i}p_{c,i}(1 - p_{c,i})^{(g+1)n} (M_{c,i} - n) \\ &\quad \times \left(\frac{(1 - \gamma_{c,i})^g - (1 - p_{c,i})^g}{p_{c,i} - \gamma_{c,i}} \right) \\ &\quad \cdot \left(\frac{p_{c,i}(1 - \gamma_{c,i})^{g+1} - \gamma_{c,i}(1 - p_{c,i})^{g+1}}{p_{c,i} - \gamma_{c,i}} \right)^{M_{c,i}-n-1}. \end{aligned} \quad (23)$$

By evaluating over the range of possible values for $L_{c,i}^0$, which is from 0 to $M_{c,i}$, the condition $L_{c,i}^0 = n$ can be further removed. Then, $P(1ct_{c,i})$ in 1) can be calculated by

$$\begin{aligned} P(1ct_{c,i}) &= \sum_{n=0}^{M_c} P(1ct_{c,i} | L_{c,i}^0 = n) \times P(L_{c,i}^0 = n) \\ &= M_{c,i}p_{c,i} \left[(1 - p_{c,i})^g \right. \\ &\quad \left. - (1 - \gamma_{c,i}) \left(\frac{p_{c,i}(1 - \gamma_{c,i})^g - \gamma_{c,i}(1 - p_{c,i})^g}{p_{c,i} - \gamma_{c,i}} \right) \right] \\ &\quad \cdot \left[(1 - p_{c,i})^{g+1} - (1 - \gamma_{c,i})p_{c,i} \right. \\ &\quad \left. \times \left(\frac{p_{c,i}(1 - \gamma_{c,i})^{g+1} - \gamma_{c,i}(1 - p_{c,i})^{g+1}}{p_{c,i} - \gamma_{c,i}} \right) \right]^{M_{c,i}-1} \end{aligned} \quad (24)$$

where the multiplier $M_{c,i}$ shows that all type c devices provide an equal probability of having a successful contention at frame i , the term with the exponent $(M_{c,i} - 1)$ represents the probability that all but one of the type c devices defer their contending packet, and the remaining part represents the probability that just one type c device will send and contend a packet.

It is worth noting that (24) includes the case $L_{c,i}^0 = 0$ which needs to be removed. Denote $P(1tc_{c,i})$ to be the result without

the case $L_{c,i}^0 = 0$. It can be calculated by

$$\begin{aligned} & P(1tc_{c,i}^0) \\ &= P(1tc_{c,i} | L_{c,i}^0 = 0) \times P(L_{c,i}^0 = 0) \\ &= M_{c,i} p_{c,i} \gamma_{c,i} \left(\frac{p_{c,i}(1 - \gamma_{c,i})^g - \gamma_{c,i}(1 - p_{c,i})^g}{p_{c,i} - \gamma_{c,i}} \right) (1 - \gamma_{c,i})^{M_{c,i}} \\ & \cdot \left(\frac{p_{c,i}(1 - \gamma_{c,i})^{g+1} - \gamma_{c,i}(1 - p_{c,i})^{g+1}}{p_{c,i} - \gamma_{c,i}} \right)^{M_{c,i}-1}. \end{aligned} \quad (25)$$

As for $P(0tc_{q,i})$, $q \neq c$ in 2), we first calculate it under the conditions $R_{q,i} \geq ga$, $L_{q,i}^g = n + m$, and $L_{q,i}^0 = n$, i.e.,

$$\begin{aligned} & P(0ct_{q,i} | R_{q,i} \geq ga, L_{q,i}^g = n + m, L_{q,i}^0 = n) \\ &= (1 - p_{q,i})^{n+m}. \end{aligned} \quad (26)$$

After removing the conditions $R_{q,i} \geq ga$ and $L_{q,i}^g = n + m$ in (26), we get

$$\begin{aligned} & P(0ct_{q,i} | L_{q,i}^0 = n) \\ &= \sum_{m=0}^{M_{q,i}-n} P(0ct_q | R_{q,i} \geq ga, L_{q,i}^g = n + m, L_{q,i}^0 = n) \\ & \cdot P(R_{q,i} \geq ga, L_{q,i}^g = n + m | L_{q,i}^0 = n) = (1 - p_{q,i})^{(g+1)n} \\ & \times \left(\frac{p_{q,i}(1 - \gamma_{q,i})^{g+1} - \gamma_{q,i}(1 - p_{q,i})^{g+1}}{p_{q,i} - \gamma_{q,i}} \right)^{M_{q,i}-n}. \end{aligned} \quad (27)$$

Similar to (24), one can obtain $P(0ct_{q,i})$, $q \neq c$ in 2) by

$$\begin{aligned} & P(0ct_{q,i}) = \sum_{m=0}^{M_{q,i}} P(0ct_{q,i} | L_{0,q} = n) \times P(L_{q,i}^0 = n) \\ &= \left[(1 - p_{q,i})^{k+1} - (1 - \gamma_{q,i})p_{q,i} \right. \\ & \left. \cdot \left(\frac{(1 - \gamma_{q,i})^{g+1} - (1 - p_{q,i})^{g+1}}{p_{q,i} - \gamma_{q,i}} \right) \right]^{M_{q,i}}. \end{aligned} \quad (28)$$

Also, based on (28), we can further calculate $P(0ct_{q,i}^0)$ by

$$\begin{aligned} & P(0ct_{q,i}^0) \\ &= P(0ct_{q,i} | L_{q,i}^0 = 0) \times P(L_{q,i}^0 = 0) \\ &= \left[(1 - \gamma_{q,i}) \left(\frac{p_{q,i}(1 - \gamma_{q,i})^{g+1} - \gamma_{q,i}(1 - p_{q,i})^{g+1}}{p_{q,i} - \gamma_{q,i}} \right) \right]^{M_{q,i}}. \end{aligned} \quad (29)$$

Finally, combining (24), (25), (28) and (29), we obtain $P(\text{Success}_c^i)$ by

$$\begin{aligned} & P(\text{Success}_c^i) \\ &= \frac{\left[P(1ct_{c,i}) \prod_{q \neq c} P(0ct_{q,i}) \right] - \left[P(1ct_{c,i}^0) \prod_{q \neq c} P(0ct_{q,i}^0) \right]}{1 - \prod_{q=1}^Q (1 - \gamma_{q,i})^{M_{q,i}}} \end{aligned} \quad (30)$$

where $\left(P(1ct_{c,i}) \prod_{q \neq c} P(0ct_{q,i}) \right)$ represents the probability of a successful transmission for all combinations of

values $L_{q,i}^g$ and $L_{q,i}^0$ that each traffic type could have, $\left(P(1ct_{c,i}^0) \prod_{q \neq c} P(0ct_{q,i}^0) \right)$ removes the scenario of $L_i^0 = 0$ where the subperiod will not occur, and $1/(1 - \prod_{q=1}^Q (1 - \gamma_{q,i})^{M_{q,i}})$ adds the condition that the subperiod will occur.

REFERENCES

- [1] *Machine to Machine (M2M) Communication Study Report*, document IEEE C80216-10_0002r7, May 2010.
- [2] Y. Zhang, R. Yu, M. Nekovee, Y. Liu, S. Xie, and S. Gjessing, "Cognitive machine-to-machine communications: Visions and potentials for the smart grid," *IEEE Netw.*, vol. 26, no. 3, pp. 6–13, May/June 2012.
- [3] S.-Y. Lien and K.-C. Chen, "Massive access management for QoS guarantees in 3GPP machine-to-machine communications," *IEEE Commun. Lett.*, vol. 15, no. 3, pp. 311–313, Mar. 2011.
- [4] S. Andreev, O. Galinina, and Y. Koucheryavy, "Energy-efficient client relay scheme for machine-to-machine communication," in *Proc. IEEE GLOBECOM Conf.*, Dec. 2011, pp. 1–5.
- [5] C.-Y. Tu, C.-Y. Ho, and C.-Y. Huang, "Energy-efficient algorithms and evaluations for massive access management in cellular based machine to machine communications," in *Proc. IEEE Veh. Technol. Conf. (VTC Fall)*, Sep. 2011, pp. 1–5.
- [6] *Service Requirements for Machine-Type Communications*, document 3GPP TS 22.368 V11.5.0, Jun. 2012. [Online]. Available: <http://www.qtc.jp/3GPP/Specs/22368-b50.pdf>.
- [7] *System Improvement for Machine-Type Communications*, document 3GPP TR 23.888 V11.0.0, Sep. 2012. [Online]. Available: <http://www.qtc.jp/3GPP/Specs/23888-b00.pdf>.
- [8] *IEEE Standard for Local and Metropolitan Area Networks—Part 16: Air Interface for Broadband Wireless Access Systems Amendment 3: Advanced Air Interface*, IEEE Standard 802.16m-2011, May 2011.
- [9] *IEEE Standard for Air Interface for Broadband Wireless Access Systems—Amendment 1: Enhancements to Support Machine-to-Machine Applications*, IEEE Standard IEEE 802.16p-2012, Oct. 2012, pp. 1–80.
- [10] M. Hasan, E. Hossain, and D. Niyato, "Random access for machine-to-machine communication in LTE-advanced networks: Issues and approaches," *IEEE Commun. Mag.*, vol. 51, no. 6, pp. 86–93, Jun. 2013.
- [11] G. Wang, X. Zhong, S. Mei, and J. Wang, "An adaptive medium access control mechanism for cellular based machine to machine (M2M) communication," in *Proc. IEEE ICWITS*, Aug./Sep. 2010, pp. 1–4.
- [12] S. Kim, J. Cha, S. Jung, C. Yoon, and K. Lim, "Performance evaluation of random access for M2M communication on IEEE 802.16 network," in *Proc. 14th ICACT*, Feb. 2012, pp. 278–283.
- [13] Y. Liu, C. Yuen, X. Cao, N. U. Hassan, and J. Chen, "Design of a scalable hybrid MAC protocol for heterogeneous M2M networks," *IEEE Internet Things J.*, vol. 1, no. 1, pp. 99–111, Feb. 2014.
- [14] W. Liu, C. Zhang, G. Yao, and Y. Fang, "DELAR: A device-energy-load aware relaying framework for heterogeneous mobile ad hoc networks," *IEEE J. Sel. Areas Commun.*, vol. 29, no. 8, pp. 1572–1584, Sep. 2011.
- [15] H.-L. Fu, H.-C. Chen, P. Lin, and Y. Fang, "Energy-efficient reporting mechanisms for multi-type real-time monitoring in machine-to-machine communications networks," in *Proc. 31st IEEE Int. Conf. Comput. Commun. (INFOCOM)*, Orlando, FL, USA, Mar. 2012, pp. 136–144.
- [16] R. Bruno, M. Conti, and E. Gregori, "Optimal capacity of p-persistent CSMA protocols," *IEEE Commun. Lett.*, vol. 7, no. 3, pp. 139–141, Mar. 2003.
- [17] I. Rhee, A. Warrier, M. Aia, J. Min, and M. L. Sichitiu, "Z-MAC: A hybrid MAC for wireless sensor networks," *IEEE/ACM Trans. Netw.*, vol. 16, no. 3, pp. 511–524, Jun. 2008.
- [18] R. Zhang, R. Ruby, J. Pan, L. Cai, and X. Shen, "A hybrid reservation/contention-based MAC for video streaming over wireless networks," *IEEE J. Sel. Areas Commun.*, vol. 28, no. 3, pp. 389–398, Apr. 2010.
- [19] S. Yin, E. Zhang, L. Yin, and S. Li, "Optimal saving-sensing-transmitting structure in self-powered cognitive radio systems with wireless energy harvesting," in *Proc. IEEE Int. Conf. Commun. (ICC)*, Budapest, Hungary, Jun. 2013, pp. 2807–2811.
- [20] R. MacKenzie and T. O'Farrell, "Throughput and delay analysis for p-persistent CSMA with heterogeneous traffic," *IEEE Trans. Commun.*, vol. 58, no. 10, pp. 2881–2891, Oct. 2010.

- [21] L. Kleinrock, *Queueing System*. New York, NY, USA: Wiley, 1975.
- [22] H. S. Chhaya and S. Gupta, "Performance modeling of asynchronous data transfer methods of IEEE 802.11 MAC protocol," *Wireless Netw.*, vol. 3, no. 3, pp. 217–234, Aug. 1997.
- [23] H. Takagi and L. Kleinrock, "Throughput analysis for persistent CSMA systems," *IEEE Trans. Commun.*, vol. 33, no. 7, pp. 627–638, Jul. 1985.



YI LIU received his Ph.D. degree from South China University of Technology (SCUT), Guangzhou, China, in 2011. After that, he joined the Singapore University of Technology and Design (SUTD) as a post-doctoral. Currently, he is a Assistant Professor with the School of Automation, Guangdong University of Technology, Guangzhou, China. His research interests include cognitive radio networks, cooperative communications, smart grid and intelligent signal processing.



ZUYUAN YANG (M'14) received the B.E. degree from the Hunan University of Science and Technology, Xiangtan, China, in 2003, and the Ph.D. degree from the South China University of Technology, Guangzhou, China, in 2010. He is currently a Researcher with the Faculty of Automation, Guangdong University of Technology, Guangzhou. His research interests include blind source separation, compressed sensing, and Internet of Things. He received the Excellent Ph.D. Thesis Award of Guangdong Province.



RONG YU (S'05–M'08) received the Ph.D. degree from Tsinghua University, China, in 2007. He was with the School of Electronic and Information Engineering, South China University of Technology. In 2010, he joined the Institute of Intelligent Information Processing, Guangdong University of Technology, where he is currently a Full Professor. He is the co-inventor of over ten patents, and has authored or co-authored over 70 international journal and conference papers.

His research interest mainly focuses on wireless communications and networking, including cognitive radio, wireless sensor networks, and home networking.

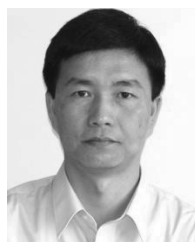

YONG XIANG (SM'12) received the Ph.D. degree in electrical and electronic engineering from The University of Melbourne, Australia. He is currently an Associate Professor and the Director of the Artificial Intelligence and Image Processing Research Cluster with the School of Information Technology, Deakin University, Australia. His research interests include signal and system estimation, information and network security, multimedia (speech/image/video) processing, and wireless sensor networks. He has served as the Program Chair, TPC Chair, Symposium Chair, and Session Chair for a number of international conferences. He serves as an Associate Editor of the IEEE Access.



SHENGLI XIE (M'01–SM'02) received the M.S. degree in mathematics from Central China Normal University, Wuhan, China, in 1992, and the Ph.D. degree in automatic control from the South China University of Technology, Guangzhou, China, in 1997. He was the Vice Dean of the School of Electronics and Information Engineering with the South China University of Technology from 2006 to 2010. He is currently the Director of the Institute of Intelligent Information Processing and the Guangdong Key Laboratory of Information Technology for the Internet of Things, and also a Professor with the School of Automation, Guangdong University of Technology, Guangzhou, China. He has authored or co-authored four monographs and over 100 scientific papers in journals and conference proceedings, and holds over 30 patents. His research interests broadly include statistical signal processing and wireless communications, with an emphasis on blind signal processing and Internet of Things.

• • •