

Date of publication xxxx 00, 0000, date of current version xxxx 00, 0000.

Digital Object Identifier 10.1109/ACCESS.2022.Doi Number

Power Sharing Control Trends, Challenges, and Solutions in Multi-Terminal HVDC Systems: A Comprehensive Survey

Hasan Alrajhi¹, Senior, IEEE, Amil Daraz², Ahmed Alzahrani¹, Hisham Babsail¹, Yazeed Alharbi¹, Fahad Alsharif¹, Abdulrahman Alattas¹, and Khaled Alshammari³

¹ Electrical Engineering Department, College of Engineering and Architecture, Umm Al-Qura University, Makkah, 21955, Saudi Arabia

² School of Information Science and Engineering, NingboTech University, 315100, Ningbo China.

³ Saudi Aramco Company, Dhahran, Saudi Arabia.

Corresponding author: Hasan K. Alrajhi (e-mail: hkrajhi@uqu.edu.sa).

ABSTRACT This extensive review article provides a comprehensive analysis of control strategies for power sharing in Multi-Terminal High Voltage Direct Current (MT-HVDC) systems utilizing voltage source converters (VSC) and multi-level modular converters (MMC). MT-HVDC systems have become essential components of modern power infrastructures due to their ability to efficiently transmit energy over long distances, connect renewable energy sources, and enhance grid stability. Effective power sharing control is of uttermost importance in these systems for ensuring equitable energy distribution between terminals and grid reliability. The paper begins with a thorough explanation of the fundamental concepts underlying MT-HVDC systems, emphasizing their significance, and examining the various configurations of such systems. The discussion then examines the functions of VSCs and MMCs in these systems, highlighting their distinct advantages and applications. The review analyses in depth the complex power sharing control strategies within VSC-based and MMC-based multi-terminal HVDC systems, as well as a number of control methods, algorithms, and optimization techniques. In addition, the article discusses difficulties and solutions associated with power sharing control in MT-HVDC systems, such as communication and synchronization issues.

INDEX TERMS Cascaded controller, DC systems, High voltage direct current (HVDC), modular multi-level converter (MMC) multi-terminal HVDC, Power Control Sharing, Voltage source converter (VSC).

I. INTRODUCTION

HVDC systems have become essential technology of significant importance for contemporary power grids within the rapidly evolving energy environment. These systems differ from more traditional Alternating Current (AC) transmission systems in a number of ways that resolve the issues and fulfill the needs of modern power networks. In the search for efficient, dependable, and sustainable energy transmission and distribution, HVDC systems and DC microgrids have ascended as transformative technologies that hold the key to a greener and more resilient future [1]. These breakthroughs have piqued the interest of researchers, engineers, and policymakers alike, hastening the development of power infrastructure and changing the future of energy management. HVDC systems are a ground-breaking solution to power transmission over

long distances as these systems offer exceptional benefits [2] by overcoming the restrictions of traditional AC systems. In other words, by converting AC electricity to DC, HVDC decreases transmission losses and boosts system efficiency. Consequently, HVDC facilitates the effective integration of renewable energy sources (RES) situated in distant locations, such as offshore wind farms and solar installations [3]. This integration has been critical in promoting sustainable energy use and in inspiring accelerated advancements in HVDC technology [4], [5].

DC microgrids, on the other hand, have emerged as game-changing alternatives for localized power delivery. These self-contained energy systems run on DC power and have a number of advantages that increase efficiency and reliability [6]. By eliminating AC-DC conversions, DC microgrids reduce energy losses and improve overall system performance

[7]. Furthermore, they seamlessly integrate various DC power sources, including solar panels, energy storage systems, and electric vehicles, thereby enabling efficient utilization of renewable resources and facilitating grid decarbonization [8]–[10]. For example, in reference [8], the authors describe the results of a demonstration study, in which the work includes building-integrated photovoltaic, a residential structure and a hydrogen fuel cell based electric vehicle (EV) indicated to provide mobility as well as electricity generation. The ultimate goal of the initiative is to achieve net zero-energy residential buildings. Adel and Sharafat [9] presented the design and testing of a self-contained solar photovoltaic (PV) system in conjunction with a DC microgrid. This system is designed to supply power to a wide range of DC and AC loads. In reference [10], the authors provide a detailed overview of hierarchical control systems that provide efficient and resilient control for a DC microgrid.

In recent years, there has been a notable surge in research endeavors dedicated to the progress and utilization of HVDC and DC microgrid technologies. Pioneering investigations have delved into control methodologies, integration with the grid, and operational challenges, all aimed at unlocking the full capabilities of these technologies. Consequently, a wealth of knowledge has been accumulated, offering invaluable insights for the prospective implementation and expansion of HVDC and DC microgrid systems.

This review article provides a comprehensive explanation of the essential ideas pertaining to MT-HVDC systems, highlighting their significance, and exploring the current configurations. Following this, the discussion explores the purposes of voltage source converters (VSCs) and multi-level modular converters (MMCs) in these systems, emphasizing their distinct benefits and uses. The review examines in depth the complex power sharing control strategies within VSC-based and MMC-based multi-terminal HVDC systems, including a variety of control methods, algorithms, and optimization techniques. In addition, the article discusses challenges and solutions associated with power sharing control in multi-terminal HVDC systems. Additionally, it will delve into various control strategies, optimization techniques, and communication methods (both communicative and non-communicative) employed in DC microgrid and HVDC systems. By scrutinizing the present state-of-the-art in this field, the objective of this review article is to contribute to the comprehension and development of effective and resilient control solutions for DC microgrids and HVDC systems.

The rest of the review article is organized as follows: Section II describes the basic overview of MT-HVDC system followed by VSC, MMC, and their hybrid configurations. Section III describes the hierarchal control structure while Section IV describes the recent control methods of the HVDC system. The frequency control method is represented by Section IV. The research trends and their solutions are documented in Section V while the last section refers to the conclusions of the article.

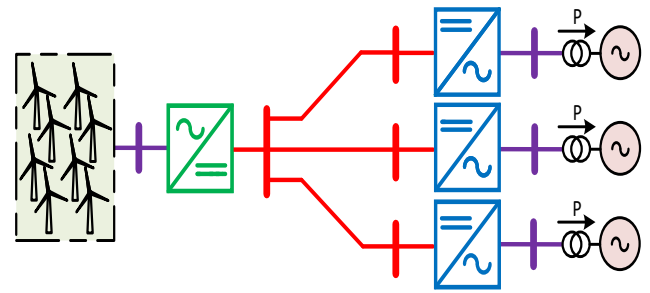

FIGURE 1. Point to multipoint representation of MT-HVDC system.

II. MULTI-TERMINAL HVDC SYSTEMS

Contemporary electrical power grids rely heavily on multi-terminal DC (MTDC) systems, alternatively referred to as multi-terminal high voltage direct current systems. Multiple HVDC terminals can be connected simultaneously with the help of these systems, greatly boosting the functions of power transmission, distribution, and grid control. MT-HVDC systems involve three or more terminals as opposed to standard point-to-point HVDC systems, effectively creating a networked infrastructure for the delivery of electricity [11]. They are specifically made to be seamlessly integrated into current AC grids, easing the transfer of power between various areas or nations. With their sophisticated capabilities for managing and directing power flow, MT-HVDC systems enable real-time modifications in electricity distribution. By controlling power quality, reducing congestion, and enabling effective long-distance electricity transfer, their use can improve grid stability.

A. MULTI-TERMINAL CONFIGURATION TYPES

1) POINT TO MULTIPOINT

A single central terminal is connected to numerous outlying terminals in this configuration. It is frequently employed in hub-and-spoke configurations, in which power is delivered from a single central location to numerous distant sites. Figure 1 denotes the point to multipoint MT-HVDC system.

2) MESHED NETWORK

Each terminal in a meshed network is linked to numerous other terminals, forming a complicated grid. This setup increases grid resilience and provides redundancy and flexibility in power transmission. The schematic diagram of meshed-based MT-HVDC system is shown in Figure 2 which represents the generalized perspective, focusing on the overarching structure and functionality rather than specific voltage values. Indeed, the DC voltage at the input side of an MT-HVDC system is subject to various influencing factors. These include the design specifications of the converters, the characteristics of the AC power source, and the specific requirements of the DC grid. Selecting the appropriate DC voltage level involves careful consideration of factors such as transmission distance, power capacity, and overall system stability.

For instance, in reference [12], the authors employed a four-terminal meshed bipolar MTDC system connecting two AC

grids with wind farms via overhead lines. In this specific case, the DC voltage level was set at 500 kV (± 250 kV). This choice was likely informed by considerations such as the distance between the AC grids and wind farms, power transfer capabilities, and system reliability requirements. Similarly, in reference [13], the authors have presented the line data and system configurations for the CIGRE systems.

3) HYBRID NETWORK

Hybrid network is the combination of point to multipoint and mesh network systems. Figure 3 shows the schematic diagram of hybrid network configuration inspired by [14].

MT-HVDC systems, which provide effective, adaptable, and dependable solutions for long-distance power transmission, renewable energy integration, and improved grid stability, are crucial components of contemporary power grids. In the changing energy landscape of today, their capacity to link asynchronous grids and to offer redundancy makes them indispensable.

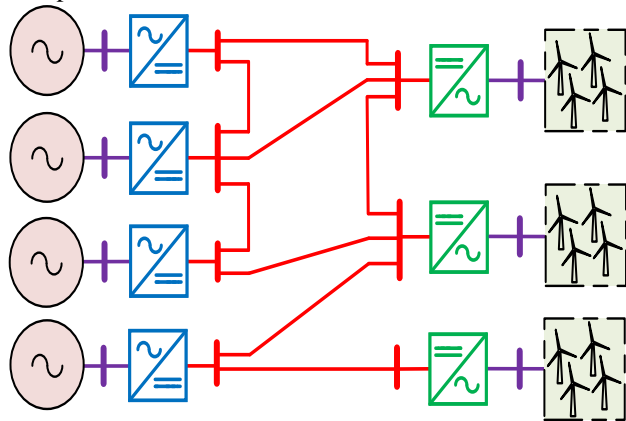

FIGURE 2. Schematic diagram of Meshed based MT-HVDC system.

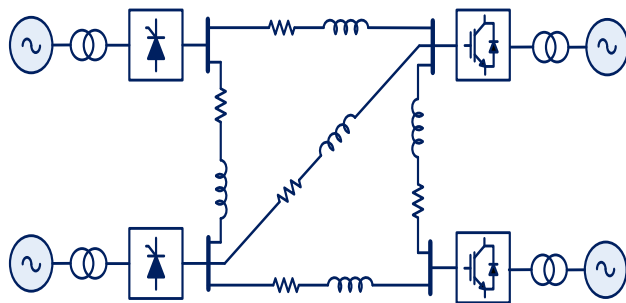

FIGURE 3. Schematic Configuration of the hybrid network.

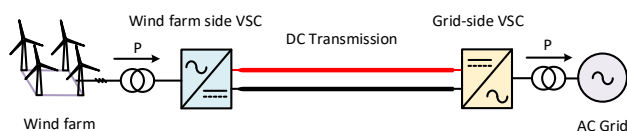

FIGURE 4. VSC-based HVDC system [15].

B. VOLTAGE SOURCE CONVERTERS IN MT- HVDC SYSTEM

VSCs are crucial components of modern HVDC systems that introduce a paradigm shift in the control and transmission of electrical power. In order to address the growing demand for flexible, effective, and high-caliber power transmission, VSC technology occupies a major role, confirming its indispensable status in today's power networks. Within HVDC systems, VSCs are responsible for converting AC power to DC and vice versa. They excel in carefully controlling power flow, making it possible to transport energy across great distances with efficiency. The incorporation of RES like solar and wind into the grid is particularly well suited for VSC-based HVDC systems, which are skilled at handling variable power supply and guaranteeing flawless grid operation. Additionally, VSCs greatly improve grid stability by correctly and quickly adjusting frequency and voltage, hence reducing voltage swings and enhancing grid resilience during disturbances [15].

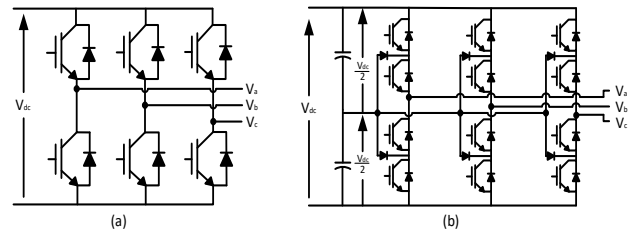

FIGURE 5. VSC layout of (a) two-level (b) Three-level.

Figure 4 shows the fundamental framework of a VSC-based HVDC system which shows that the DC voltage rating is 60kV, while the allowed maximum power to be transferred is 100MW [15].

VSC technology allows for sophisticated regulation of power distribution among terminals and grid interconnection in multi-terminal HVDC systems [16]. After a blackout, it can start the grid restoration process, offering black start capabilities and helping with grid resynchronization. Based on their voltage levels and control methods, VSCs can be classified into: the two-level and three-level VSC layouts as shown in Figure 5. These two topologies are the most popular VSC variants [17], [18].

1) TWO-LEVEL VSC

A two-level VSC has two voltage levels, which are often indicated by the symbols $+V_{dc}$ and $-V_{dc}$, where V_{dc} stands for the DC link voltage. Insulated gate bipolar transistors (IGBTs) or other analogous semiconductor switches are used. The voltage applied to the load in this configuration can either assume the full positive or full negative DC link voltage. Even though this design is simple, the resulting output voltage pattern may have more harmonics as a result.

2) THREE-LEVEL VSC

A three-level VSC uses additional switching components such as Neutral Point Clamped (NPC) or flying capacitor topologies to provide three voltage levels, which are often

denoted as +V_{dc}, 0, and -V_{dc}. These extra elements help to reduce harmonic content and create a smoother voltage waveform. The three-level VSC adds an additional level of zero voltage, which reduces the output voltage's harmonic content and eventually produces a cleaner waveform.

VSC technology effectively facilitates the integration of renewable energy sources while providing precise control, improving grid stability, and upgrading current HVDC systems. The exact requirements of the HVDC system determine which VSC architecture should be used; three-level VSCs are frequently privileged due to their lower harmonic content and smoother voltage waveforms.

C. MULTI-LEVEL MODULAR CONVERTERS IN MT-HVDC

A notable development in the fields of power electronics and high-voltage direct current (HVDC) technology is the Multi-Level Modular Converter (MMC). Due to its exceptional performance and several advantages in terms of efficiency, grid integration, and system dependability, MMC technology has received a great deal of attention and praise. The landscape of HVDC and renewable energy systems has been significantly altered by this ground-breaking power conversion technique. The outstanding ability of MMC technology to manage high voltages makes it particularly ideal for ultra-high voltage applications like long-distance power transmission. MMC configurations produce an output voltage with little harmonic content, resulting in a more pristine waveform [19], [20]. This feature helps to reduce electromagnetic interference and improve the effectiveness of the entire system. Because of its modular design, MMC is adaptable and can be customized to a variety of power ratings and voltage levels. For a wide range of applications across numerous industries and grid environments, this versatility is essential. Additionally, its ability to monitor and control power flow makes it easier to securely connect asynchronous AC networks and manage renewable energy sources. Power semiconductor components, capacitors, and voltage sources are used in combination by Multi-Level Modular Converters (MMC) to carry out their functions. Figure 6 shows the core schematic diagram for MMC-based HVDC. Two main categories can be used to classify these arrangements [21]:

1) HALF-BRIDGE MMC

Each sub-module in a half-bridge MMC is made up of a half-bridge circuit coupled to a capacitor. To achieve the desired voltage level, these sub-modules are stacked in series. The operation entails switching semiconductor devices to generate numerous voltage levels. The capacitors store and release energy, enabling the converter to generate a nearly sinusoidal output voltage with low harmonic content. The half-bridge MMC is a basic device that is ideal for medium-voltage applications [20].

2) FULL-BRIDGE MMC

A full-bridge Multi-Level Modular Converter (MMC) employs full-bridge sub-modules, each of which has two semiconductor devices and a capacitor. A full-bridge MMC operates similarly to a half-bridge MMC, except it integrates more sub-modules per arm. This configuration produces

more voltage levels, which contributes to a more pronounced reduction in harmonic content within the output voltage. Full-bridge MMCs are commonly used in high and ultra-high voltage HVDC applications [22].

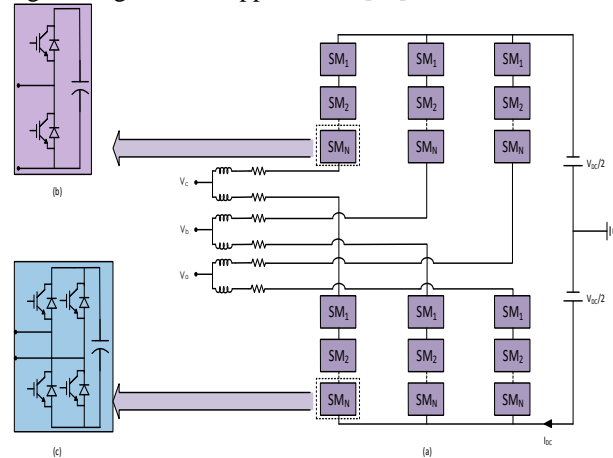

FIGURE 6. The modular multi-level converter structure diagram. (a) Modular multilevel converter (MMC) topology; (b) Half-bridge sub-module; and (c) Full-bridge sub-module.

The modular multi-level converter layout is shown in Figure 6 where SM represents a sub-module of the half-bridge topology [23].

3) HYBRID CONFIGURATIONS

In order to construct a Multi-Terminal HVDC (MT-HVDC) system, a hybrid configuration of a HVDC system combines two different kinds of converters: (1) Voltage Source Converters (VSC) (2) Line-Commutated Converters (LCC). Employing a hybrid strategy, each converter technology's distinct benefits are brought to bear for a variety of applications [24], [25]. VSC and MMC technology are combined inside a single system in hybrid designs for multi-terminal HVDC systems. In this configuration, VSCs and MMCs collaborate to take advantage of the benefits of each technology. With improved control, dependability, and grid performance, this combination offers a flexible and effective solution for different grid applications. The hybrid approach offers more flexibility in regulating electricity flow, maintaining voltage, and ensuring grid stability by allowing for advanced control tactics. The performance of the system can be real-time optimized by tweaking the control algorithms. MMCs are renowned for creating high-quality, low-harmonic AC waveforms. Cleaner output voltage, which is necessary for sensitive loads and lowers electromagnetic interference, is made possible by combining MMCs and VSCs. The system has redundancies because both VSCs and MMCs are present. The hybrid system's other technologies can continue to function if one component fails, reducing the chance of a total system shutdown and ensuring grid resilience [23], [26]–[28].

III. HIERARCHICAL CONTROL

The hierarchical control structure consists of three levels: (1) Primary (2) Secondary (3) Tertiary. It divides control objectives into multiple levels, each controlling specific

tasks: primary focus on controlling the voltage and current control loops by using local measurements; secondary control layer focuses on restoring voltage, frequency and power mismatches in case of disturbance in the system; tertiary control focus on optimizing the system performance in economic and power management. Hierarchical control is a common concept in HVDC and DC microgrid systems where the primary control receives its set point from the secondary control, and the secondary control receives its set point from the highest control at the tertiary layer.

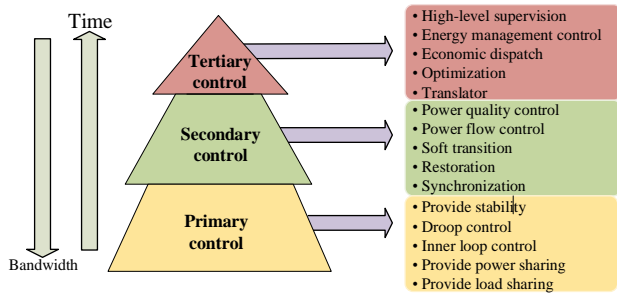

FIGURE 7. Hierarchical structure of the power control

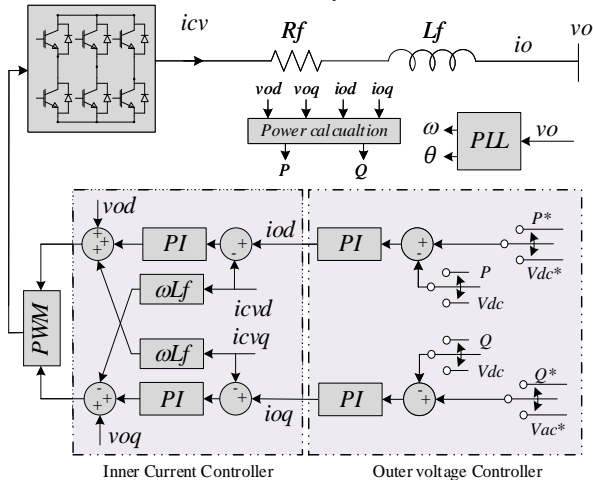

FIGURE 8. Structure of primary control layers [33]

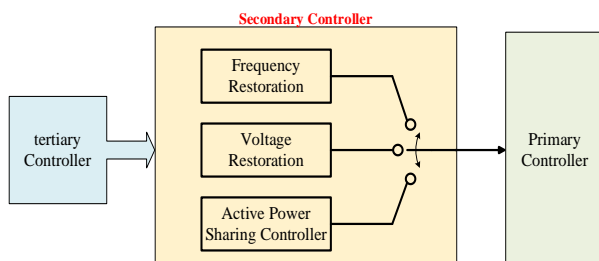

FIGURE 9. Structure of the secondary controller

Nevertheless, one of the primary limitations of hierarchical control systems is the necessity for communication lines between the layers. Figure 7 represents the hierarchical structure of the power control.

A. PRIMARY CONTROL LAYER

The primary or local controller, as shown in Figure 8, represents the first and fastest level in hierarchical control, it employs a centralized or decentralized control technique to provide active and reactive power and load sharing between converters and Distributed Generators (DGs), it also uses different controllers like power and current controllers to provide internal control, which is done by controlling voltage and current output of the converters [29]–[32].

B. SECONDARY CONTROL LAYER

The secondary controller functions similarly to an Energy Management System (EMS) and can operate in centralized, decentralized, or distributed configurations. Primarily, it consists of a voltage and/or current regulator intended to dampen oscillations caused by the primary controller. In essence, its function within the hierarchical control framework is to manage power quality, thereby augmenting the operation's dependability and safety [33]–[35][36]. Figure 9 shows the basic structure of the secondary controller.

C. Tertiary control layer

This control layer is the highest level in a hierarchical

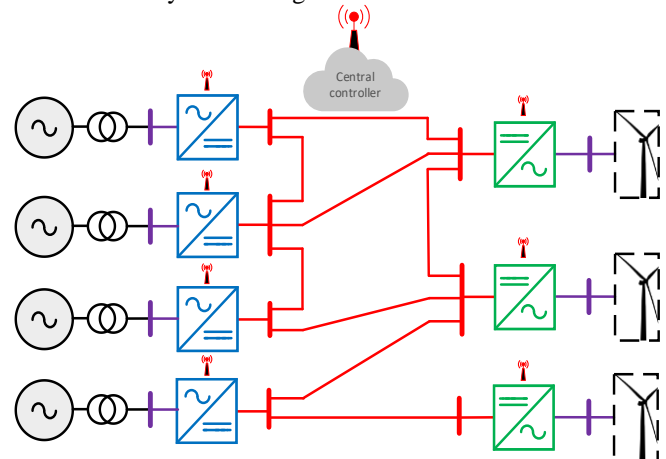

FIGURE 10. Generic model of centralized control

control structure and it is often employed in complex systems such as HVDC and DC microgrid systems. Its main purpose is to boost the system's efficiency and effectiveness, with a focus on saving money and conserving energy. Economic efficiency is optimized by the tertiary control layer, which considers energy costs, income generation, and resource distribution. This level's goal is to maximize profits while simultaneously minimizing operating expenses [37], [38].

This layer plays a crucial role in regulating power distribution. When renewable energy sources are used, it is able to effectively distribute energy by modifying the reference points for various components [39], [40]. Tertiary control acts as a mediator and translator between the primary and secondary levels of control. It communicates directional information from the secondary control layer to the primary

control layer. The efficiency of the system depends on the quality of the communication between the tertiary control layer and the lower control layers, which enables adjustments and responses to be made in real time [41], [42]. The writers of reference [41] employed tertiary control to establish reasonable reference values for primary and secondary controls. To achieve this goal, they used Security Constrained Economic Dispatch (SCED), which enabled them to create an effective and secure HVDC/AC network architecture. In reference [42], the system's energy was monitored and regulated via tertiary control.

IV. POWER DISTRIBUTING CONTROL APPROACHES

In modern power systems, especially MTDC designs, power sharing is an essential component. In order to maintain dependable service, it is necessary to distribute electricity among many sources or terminals. Power sharing controllers have come a long way in recent years, playing a crucial role in ensuring efficient and accurate power distribution and control [10].

A. CENTRALIZED CONTROL

This sort of centralized control as shown in Figure 10 collects information from each converter and delivers instructions to each converter, allowing for worldwide coordination. A central unit oversees monitoring and controlling the power and voltage levels in a system. It accomplishes this by using a communication channel to establish common reference points for all converters. This strategy improves control and precision when it comes to regulating voltage and frequency variations. Nonetheless, the centralized control system's dependability is subject to the resilience of the communication network, which may be jeopardized in the event of network failures [29], [43], [44].

1) FUZZY LOGIC CONTROL

Fuzzy logic, a powerful mathematical tool, has a wide range of applications, including HVDC and DC microgrid systems. Fuzzy logic provides a flexible framework for decision-making and control inside these systems, analyzing and interpreting uncertain and imprecise data effectively. HVDC and DC microgrid systems can improve many key activities such as power flow optimization, voltage control, and fault detection by incorporating fuzzy logic, all with the aim of increasing the dependability, stability, and efficiency of emerging energy systems. Recent research has presented novel ways based on fuzzy logic [45]–[48]. For instance, the authors in [48] presented a fuzzy logic-based adaptive droop control system. This method makes use of an expert's knowledge to calculate the proper droop coefficient based on expected system behavior. This is accomplished by monitoring DC voltage deviation and power capacity margin and making dynamic modifications to lower DC voltage deviation. Another study [47] proposed a fuzzy logic-based power management system to handle power sharing difficulties in DC microgrids caused by the intermittent nature of RS. The goal of this technology is to improve power sharing and bus voltage stabilization. The

recommended control tactic is based on changes in power availability from sources as well as voltage regulation. Pena-Aguirre et al. [46] also presented a fuzzy logic-based power management technique (PMS) for residential DC microgrids. This novel technique finds a balance between extremely simple and overly sophisticated systems, answering the requirement for practical implementation in resource-constrained devices. The suggested PMS includes a small set of rules to provide continuous power supply, minimize storage unit utilization, and maintain balance among various power sources, storage units, and loads.

B. DECENTRALIZED CONTROL

In this type of control, each controller works solely, and there is no communication between the controllers as shown in Figure 11. It has high reliability because it is independent of communication but suffers from many drawbacks, such as voltage division when controlling the power, stability problems, and accurate power sharing.

1) DROOP CONTROL

Researchers have proposed different droop-based control approaches aimed at balancing DC voltage management and equitable power distribution. Tang and Zhao presented an

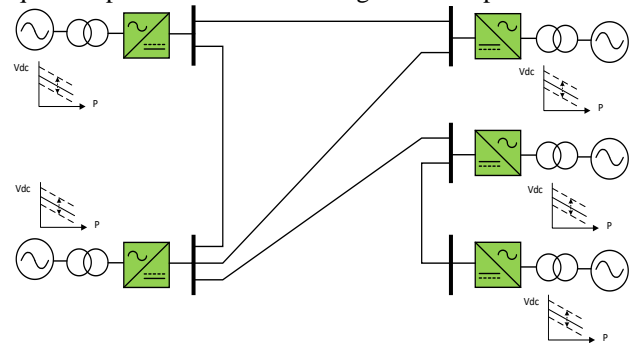

FIGURE 11. Generic model of centralized control

upgraded droop control strategy in reference [50] that distributes a common connection point across converters within a network. Total power is determined by voltage control at this single connection point rather than depending on local measurements from each converter. This approach, however, has a drawback where it ignores the local voltage of individual converters. When one converter's local voltage reaches its maximum or minimum value, it might have a negative impact on active power sharing. Another study, presented in reference [49] proposes an adjustable droop control approach based on decoupled DC-voltage and frequency variations. Another reference [51] proposes droop control for MMC-based MTDC networks, which includes a mutual control mechanism to regulate DC voltage droop. This methodology serves as a thorough tool for ensuring that both converters and system restrictions are followed when operating MTDC networks in droop control mode.

2) DECENTRALIZED COOPERATIVE CONTROL

The authors in [52] have suggested a decentralized control strategy based on power and frequency relationships. The

system consists of three converters connected to the mainland and renewable energy sources (RES). The system operates normally in the dead band area, but when the frequency increases to the increment band, the converters in reverse power transfer and two-direction converters deliver maximum power, while the forward-direction converter delivers minimum power. RES stops generating power when the frequency increases to the increment band. When the frequency increases to the increment band, the power grid in charge of reverse power transfer will deliver the minimum power, while the other two will deliver the maximum, and RES will operate in MPPT mode.

3) FEEDFORWARD CONTROL

The feedforward mechanism is used to improve DC voltage control and power sharing. In reference [53], the authors employed a feedforward technique to supply the current controller of the converter unaffected by AC side load requirements. The converters were designed in the dq reference frame, with the d-axis controlling the DC voltage and active power and the q-axis controlling the AC voltage and reactive power. To cancel out the influence of the load current on the VSC, maintain the DC voltage and active power setpoints, and prevent unwanted reverse power flows through the converters during disturbances or demand changes in the AC networks, a feed-forward signal containing the d and q axes of the load current is added. Mehrasa et al. [54] proposed a control approach that combines both feedback and a feed-forward strategy. This method was utilized to control the power sharing between two inverters, with the objective of sustaining grid strength and achieving a unity power factor. Voltage and current control loops are created with a combination of feedback and feed-forward techniques in order to dampen filter capacitor voltage fluctuations based on the following equations:

$$(u_{cdi})_{FB} = \frac{\left(k_{pd}^i + \frac{k_{id}^i}{s}\right) e_d^i - \omega L_{ci} i_{cqi} + v_{cd}}{v_{dci}} \quad (1)$$

$$(u_{cqi})_{FB} = \frac{\left(k_{pq}^i + \frac{k_{iq}^i}{s}\right) e_q^i + \omega L_{ci} i_{cdi} + v_{cq}}{v_{dci}} \quad (2)$$

$$(u_{cdi})_{FF} = \frac{k_{vd} e_d^v + k_{id} i_{cdi}^*}{v_{dci}} \quad (3)$$

$$(u_{cqi})_{FF} = \frac{k_{vq} e_q^v + k_{iq} i_{cqi}^*}{v_{dci}} \quad (4)$$

Where $e_d^i = i_{cdi}^* - i_{cdi}$, $e_q^i = i_{cqi}^* - i_{cqi}$, $e_d^v = v_{cd}^* - v_{cd}$, and $e_q^v = v_{cq}^* - v_{cq}$. By combining Equations (1)-(4) we get:

$$u_{cdi} = (u_{cdi})_{FB} + (u_{cdi})_{FF} \quad (5)$$

$$u_{cqi} = (u_{cqi})_{FB} + (u_{cqi})_{FF} \quad (6)$$

4) ADAPTIVE DECENTRALIZED DROOP CONTROL

Adaptive droop-based control is used to improve power sharing accuracy and maintain power equilibrium, especially during converter station outages. However, this approach's

reliance on communication technologies can have a negative impact on reliability. Recent research has attempted to overcome this by providing decentralized control approaches based on adaptive droop principles.

Reference [55] offers an illustration of a decentralized control method utilizing adaptive droop, which encompasses primary and secondary layers. The elementary layer manages power sharing without depending on communication by making adaptive droop adjustments based on electric pricing and State of Charge (SoC). The secondary layer includes an integrator block to reduce DC voltage variations caused by droop control.

Similarly, [56] presents a decentralized adaptive droop system centered on energy sharing. The rectifier converter in this design uses a typical droop converter (V-P) to manage DC voltage. In the event of a rectifier station overload, the operator assigns a specific power setpoint to each converter. Each converter evaluates the power available in the rectifier in a unique way.

$$P_{available} = \left(\frac{\left((i_{dc}^i * R_{dc}^i) + v_{dc}^{meas} \right) + v_{dc}^{nominal}}{v_{dc}^{max} - v_{dc}^{min}} \right) * P_{dc}^{max} \quad (7)$$

Where v_{dc}^{min} and v_{dc}^{max} represent the minimum and maximum permissible voltages, respectively.

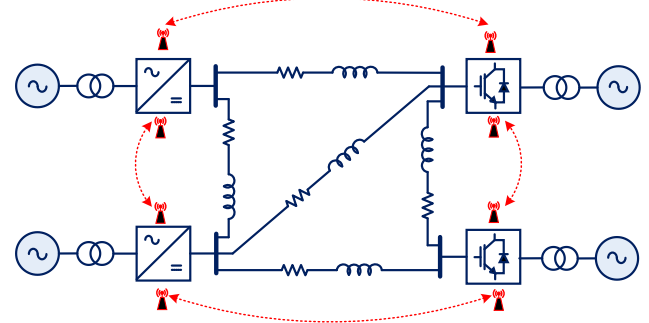

FIGURE 12. Generic model of distributed control

Table 1 Comparison of centralized, decentralized, and distributed control methods.

	Centralized	Decentralized	Distributed
Reliability	Poor [60]	Maintained [60]	Maintained [60]
Freedom	Low [61]	High [61]	Good [61]
LC Control By	Central unit [5]	Local measurement [52]	Communication links [61]
Operation	Optimal and efficient [20]	Optimal with limit [55]	Optimal [62]
Central Controller	Dependent [5]	Independent [52]	Independent [59]
Power Sharing Control	High [48]	Low [52]	High [59]
Plug & Play	Poor [63]	Easy [63]	Requires communication link [63]

5) DECENTRALIZED SECONDARY CONTROL

In a decentralized control system, a secondary controller works alongside the primary controller to perform specific

duties, particularly in the presence of disruptions or communication failures. In the study [57], a decentralized secondary controller was introduced to collaborate with the Master-Slave control system, demonstrating this point. The secondary controller involves only slave converters and is responsible for voltage and frequency monitoring. It responds to errors by initiating three modes to resolve system problems. In addition, in [58], a novel decentralized secondary control strategy for the Multi-Terminal DC (MTDC) system was implemented. This strategy is intended to restore system frequency and to modify the power sharing ratio by utilizing generator-specific parameters.

C. DISTRIBUTED CONTROL

This type of control method is a hybrid of decentralized and centralized control strategies. There are some advantages to taking both types, as shown in Figure 12, where each controller unit has a communication link between neighboring control units to achieve many objectives such as power sharing and equal power sharing. If there is communication loss, the system will operate normally but without the advantages of communication. The biggest drawback is that the system is dependent on the communication link for accurate power sharing, equal load, and voltage deviation [59]. Table 1 indicates the comparison of centralized, decentralized, and distributed control methods.

1) DISTRIBUTED COOPERATIVE CONTROL

The authors of reference [59] presented a nonlinear, time-varying droop gain that is independent of communication systems. This method is essential for voltage regulation and ensures equitable power distribution by communicating with nearby converters. Another control approach is presented in [64], which describes a protocol-based strategy. This network consists of a frequency regulation subagent and a load ratio subagent in order to maintain frequency stability and balance power distribution between connected stations within the same AC grid. The local controller manages DC network voltage stability and power distribution among VSC stations. It integrates conventional P-V control with power and current regulators. In addition, [65] presents a model-free, (V-I) based distributed cooperative frequency control technique. This method is appropriate for large-scale systems because it does not rely on a mathematical model of the MT-HVDC system.

2) MULTI-AGENT DISTRIBUTED CONTROL

The article cited in [62] examines a multi-agent system with two primary objectives. Based on the Distributed Energy Resources (DER) rating, the first objective is to attain voltage and frequency parity between nodes. The focus of the paper is on frequency control for active power and voltage control for reactive power. Adjusting control parameters and monitoring the errors of neighboring agents resolves these issues. Each generator or energy source has a maximal generation capacity, thereby introducing the following generation limitation:

$$P_{\min} \leq P_i, P_j \leq P_{\max} \text{ and } Q_{\min} \leq Q_i, Q_j \leq Q_{\max} \quad (8)$$

Likewise, when considering the maximum acceptable frequency deviation, the droop gain must fall within a specific range, resulting in constraints on the droop gain, as follows:

$$\begin{aligned} 0 \leq m_{P_i}, m_{P_j} &\leq \frac{\Delta f_{\max}}{P_{\max}} \\ 0 \leq m_{Q_i}, m_{Q_j} &\leq \frac{\Delta V_{\max}}{Q_{\max}} \end{aligned} \quad (9)$$

It is suggested in [66] to use a voltage observer to manage the voltage in order to rectify the power mismatch in the primary droop controller. Based on their local measurement and the estimation of their neighbours, each observer makes an estimate of the voltage value. It will use communication links to provide a fresh estimate to the secondary control in case of a voltage variation. It will also employ neighbouring converter communication to rectify power mismatches in power sharing depending on droop gain.

3) HIERARCHICAL DISTRIBUTED CONTROL

The proposed strategy in reference [67] presents a hierarchical distributed control that comprised of a phase-autonomous implicit synchronous generator (P-VSG), a distributed secondary power flow regulator, and a distributed secondary voltage regulator.

The P-VSG controller is deployed for primary control of distributed generator (DG) units. It enables individual and adaptable power and voltage control for each phase, with the ability to independently regulate the magnitude of each phase. An active power sharing regulator ensures equilibrium among phase powers while preserving proper power distribution among DG units. Similarly, a reactive power sharing regulator maintains balance in reactive power sharing. Voltage regulation comprises a secondary voltage regulator and a voltage unbalance factor (VUF).

D. MASTER SLAVE WITH DROOP CONTROL

In traditional master-slave systems, one converter serves as master, while the remaining converters serve as slaves. The master converter is in charge of voltage management, while the slave converters operate in constant power mode. The dependency on communication infrastructure is an inherent shortcoming of this control mechanism. Several research have advocated the installation of master-slave systems with droop control to reduce this dependency.

To improve system reliability, another approach, as detailed in [68], involves using a master-slave system with adaptive droop control. This entails modifying the master converter's voltage regulation until it enters a preset dead zone. Slave converters then act in power control by boosting or decreasing power output. Alyami in [69] discusses the use of master-slave systems with droop control in Modular Multilevel Converter (MMC) converters. The focus of this study is on a Multi-Terminal DC (MTDC) grid with four MMC terminals. MMC-A, MMC-C, and MMC-D are all onshore, whereas MMC-B is located offshore. Onshore MMCs provide greater flexibility in importing power into the DC connection, demanding coordinated measures to avoid power imbalances during outages. Furthermore, the

author in [70] offers a unique nonlinear droop (ND) controller-based adaptive master-slave (AMS) control technique. One master station and multiple slave stations with ND control compose the AMS system. The master station maintains constant DC voltage control, whereas the slave stations determine their operational statuses using DC voltage.

E. AUTONOMOUS CONTROL

The concept of autonomous control is emerging as a response to the limitations of centralized control systems caused by communication loss. It entails the addition of a decentralized or distributed controller with its own set of goals for dealing with malfunctions, communication disruptions, or system disturbances. In the context of [71], an autonomous supplemental controller capable of proportional power distribution and voltage regulation is proposed. To improve system accuracy and dependability, this autonomous control system employs both feedback and open-loop techniques. Yang et al. [72] introduce a flexible control technique for managing power flow in DC lines that makes use of an enhanced HVDC grid analytical model and an adaptive droop control approach. This method is based on a linear equation, which eliminates the need to solve complex

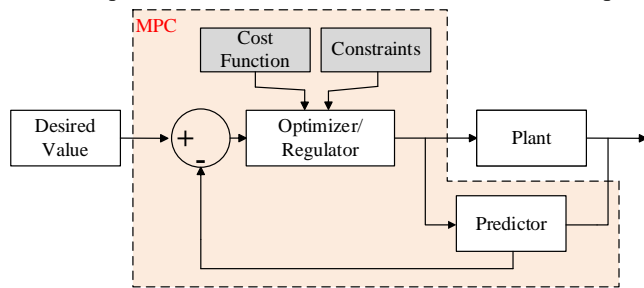

FIGURE 13. MPC control structure [83]

global AC-DC power flow equations, lowering computational complexity. It can regulate specific DC line powers separately or distribute them proportionally among DC lines. The authors of [73] suggest a DPC-VCC coordination technique that focuses on enabling timely power-sharing between converters during substantial disturbances at one of the converter stations.

F. MODEL PREDICTIVE CONTROL (MPC)

The model predictive control (MPC) strategy as shown in Figure 13 offers a fast and dynamic response that can predict future status and output. The proposed approach offers the benefit of handling multiple input-output challenges, formulated as an optimization problem with flexible system inputs. Despite its numerous advantages, Model Predictive Control (MPC) has several drawbacks, as detailed in references [74]–[77]. These disadvantages encompass the need for a substantial number of weighting factors in experimental design and the complexity of employing a trial-

and-error approach. In reference [78], the authors introduced the Sequential Modular Predictive Control (SMPC) method to address this issue. It involves optimizing for a constant value denoted as "k" at each sampling point. To tackle the challenge of finding the optimal control solution, a series of inputs is generated and optimized based on the established cost function, considering measurements of the converter's current state and previous inputs. This process is then repeated at the next sampling constant, $k + 1$. In reference [79], the authors introduced a central controller based on MPC to address power imbalances in transformers using a small signal model. Similarly, MPC is utilized in reference [80] to mitigate voltage deviations and manage reactive power fluctuations in Offshore Wind Farms (OWFs). The authors in reference [81] employed the alternating direction multiplex method (ADMM) to solve the MPC problem in a decentralized manner without sacrificing the optimality of the primal problem.

G. ADAPTIVE DROOP CONTROL

The authors of [83] propose an adaptive voltage droop control based on reference power that improves the performance of the VSC-MTDC system during significant disturbances by dynamically adjusting the control factors associated with reference power. In a related article [84], the authors describe a method in which the optimal selection of voltage droop gain occurs in response to alterations in power generation. This selection is based on an algorithm that ensures the interconnected networks' minimal requirements are met. A novel technique known as Power Margin (PMT) droop control is proposed in [85]. A power margin correction factor is incorporated into the droop coefficient in PMT, establishing a quadratic relationship between voltage and power. This allows each station to make adaptive power margin adjustments. Reference [86] introduces a cost-based adaptive (CBA) droop control for VSC-MTDC systems. This approach utilizes an enhanced economic dispatch technique to calculate the cost-based droop gain, aiming to reduce active power generation costs while ensuring compliance with generation and power balance constraints. The authors of [87] propose a novel adaptive droop control method that employs a distributed consensus algorithm for frequency backing and power allocation. This strategy is composed of three levels: a lower level of control, a consensus stage, and a coordination by optimization stage. The consensus phase computes error corrections for the droop coefficient based on data collected from neighboring entities. The lower level of control includes droop control, frequency regulation, and DC-link voltage regulation. Coordinated optimization seeks to minimize the MTHVDC network's cost functions. Similarly, the article [88] presents an adaptive time-graded control method based on basic power system protection concepts. Table 2 provides a detailed comparison of numerous power-sharing strategies.

Table 2 Comparison of power sharing control methods

Control Techniques	Concept	Advantage	Disadvantage	Ref
Fuzzy Logic Control	Uses degrees of truth to handle ambiguity and uncertainty in decision making processes.	<ul style="list-style-type: none"> Flexible in decision making and control Optimize critical operations. 	<ul style="list-style-type: none"> Relies on human expertise to define a membership function Lack of standardization 	[45]–[48]
DC Droop	Control the droop using measures from PCDC.	<ul style="list-style-type: none"> Better control of power distribution Improved voltage regulation. 	<ul style="list-style-type: none"> The system may deteriorate due to neglect of local voltage. 	[50]
	Uses double droop gain.	<ul style="list-style-type: none"> Increases DC voltage Frequency support Minimizes the relations between DC and AC grids induced by double droop control. 	<ul style="list-style-type: none"> No stability analysis was conducted, so stability limits are unknown. 	[49]
Decentralized Cooperative	All the HVDC grids participate in controlling the power and frequency.	<ul style="list-style-type: none"> Great control over the frequency. High reliability. Good power control over renewable sources 	<ul style="list-style-type: none"> Two of the HVDC grid is just one directional power. 	[52]
Feedforward	Feedforward technique is employed	Seamless operation during unbalanced grid conditions.	<ul style="list-style-type: none"> Complexity of control strategies. 	[53]
	Feedforward- feedback technique is employed	<ul style="list-style-type: none"> Maintain a unity power factor Optimal Performance. 	<ul style="list-style-type: none"> Implementation Challenges Sensitivity problems. 	[54]
Adaptive Decentralized Control.	Based on the electric price and the SoC.	No communication and consider the voltage division in the calculation of droop gain and the droop gain Have a limit by CGR.	<ul style="list-style-type: none"> No power sharing and equal load. 	[55]
	Adaptive, wireless	Excellent power sharing	<ul style="list-style-type: none"> High voltage deviation. 	[56]
Secondary Decentralized Control	Works in case of disturbance in the master slave primary layer.	<ul style="list-style-type: none"> High reliability Good power sharing. 	<ul style="list-style-type: none"> The need for communication in the primary layer Complex design. 	[57]
	decentralized secondary control strategy for the MTDC system was implemented.	<ul style="list-style-type: none"> Effective power sharing Reliable. 	<ul style="list-style-type: none"> High frequency deviation. 	[58]
Distributed Cooperative Control	Nonlinear time-varying droop gain.	<ul style="list-style-type: none"> Good reliability on the voltage. Good power sharing only with communication. Equal load only with communication. The voltage is independent of communication. 	<ul style="list-style-type: none"> The system power is not stable in case of communication loss. 	[59]
		<ul style="list-style-type: none"> Effectively mitigates the variation in the DC-bus voltage resulting from power reallocation and frequency support. 	<ul style="list-style-type: none"> Susceptible to degradation due to communication delays. 	[64]
	VI-based distributed cooperative frequency control strategy.	Model free and learns from the present and the past sampling data of frequency in the absence of the mathematical model of MT-HVDC systems.	<ul style="list-style-type: none"> Some system parameters, such as the parameters p, q and γ of the local performance index, impose a significant influence on the control effect 	[65]
Multi-agent control	Alters each DER's active power output to reduce the deviation from the desired power sharing ratio.	<ul style="list-style-type: none"> Frequency variation due to primary control can be rectified, accurate, stable, reliable, repost against single point failure and simple. 	<ul style="list-style-type: none"> Complexity in terms of communication and coordination among local controllers and agents. 	[62]
	Uses an observer to regulate the voltage and power sharing	<ul style="list-style-type: none"> Excellent power sharing Excellent voltage regulation 	<ul style="list-style-type: none"> Relies heavily on communication. 	[66]
Hierarchical distributed control	Distributed secondary control with P-VSG	<ul style="list-style-type: none"> Control layer for secondary power regulation and voltage stabilization. It allows output stage powers, voltage outlines, and power condition. Communication time delays are also considered 	<ul style="list-style-type: none"> Applies exclusively to Energy Storage Systems (ESS), but their availability may be limited in certain areas and for certain Distributed Generation (DG) units. Additionally, some DG units such as Photovoltaic (PV) systems are non-dispatchable. 	[67]
	M-S with adaptive droop	<ul style="list-style-type: none"> Higher reliability 	<ul style="list-style-type: none"> Higher cost because of the use of LLC 	[68]

		<ul style="list-style-type: none"> Better control over the voltage compared to adaptive droop 	converter.	
Master-Slave Droop Control	M-S with NL droop	<ul style="list-style-type: none"> Precise active power control in steady- state, Allows superior dynamic performance in transient state. 	<ul style="list-style-type: none"> Requires high communication speed 	[70]
	Autonomous control work in case of disturbance.	<ul style="list-style-type: none"> Excellent power sharing and voltage regulation, high reliability, and equal power sharing. 	<ul style="list-style-type: none"> Power sharing only with communication. 	[71]
Autonomous control	Using an adaptive droop control strategy to autonomously regulate DC line power flows in HVDC grids, without needing any additional power converters or equipment.	<ul style="list-style-type: none"> Has the capability to autonomously adjust the specified DC line powers to predefined values. Allocates power among DC lines in proportion without the necessity of solving nonlinear power flow equations for the DC grid. Cost Reduction Grid stability due to the elimination of a complex communication system. 	<ul style="list-style-type: none"> Requires communication of system data in case of line outages to update model. 	[72]
	Coordination policy between VCC and DPC.	<ul style="list-style-type: none"> Improves DC voltage deviation Provides quick power sharing among converters in the event of disturbances Improves system transient response. 	<ul style="list-style-type: none"> Tested on a simplified model of MTDC. Relies on communication. 	[73]
	Priority.	<ul style="list-style-type: none"> Evaluate each objective of cost functions sequentially Minimize circulating current 	<ul style="list-style-type: none"> Required more timing 	[78]
Model Predictive Control	Centralized MPC.	<ul style="list-style-type: none"> Provides accurate power sharing Suppresses voltage deviations Improves safety without changing droop gains. 	<ul style="list-style-type: none"> Conventional droop methods can be impacted by communication latencies. 	[79]
	Decentralized.	<ul style="list-style-type: none"> Scalable Flexible and security. 	<ul style="list-style-type: none"> Complexity of calculations 	[80]
	Distributed MPC work for inertial and frequency support.	<ul style="list-style-type: none"> Good inertial Frequency support Solves the optimization problem in distributed manner. 	<ul style="list-style-type: none"> Relies on communication Have harmonic related problems. 	[81]
	Compromises between DC voltage and AC frequency	<ul style="list-style-type: none"> It solely relies on local data from each GSC, thereby eliminating the need for reliance on the communication link. 	<ul style="list-style-type: none"> Not be able to accommodate unpredictable faults much different than tested scenarios during development Seeking a compromise operating point may delay fast tripping needed to isolate severe faults from spreading. 	[83]
Adaptive Droop Control	Novel power margin (PMT) droop control allows each station to make self-adaptive regulations based on available power margin.	<ul style="list-style-type: none"> Enhances the collaborative operational capabilities of multiple converter stations. Minimizes fluctuations in grid-connected power. Effectively decreases deviations in DC voltage to bolster the operational stability of the MTDC grid. 	<ul style="list-style-type: none"> Different combinations could lead to different control performance. Effectiveness is measured by comparing to other adaptive droop control methods. 	[85]
	Cost-based adaptive droop control.	<ul style="list-style-type: none"> Deliver greater impacts to the economic process of the MTDC system. Achieves robust control. 	<ul style="list-style-type: none"> Necessitates an initial investment in communication infrastructure, presenting implementation challenges that can elevate the overall complexity and cost of the system. 	[86]

Novel distributed consensus algorithm for frequency support and power sharing.	<ul style="list-style-type: none"> • Lessen generation expense. • Minimize frequency deviation cost • Minimize converter losses. 	<ul style="list-style-type: none"> • Complex • Relies heavily on communications • Sensitive to network changes. 	[87]
Adaptive time graded based on the elementary ideas of power system security.	<ul style="list-style-type: none"> • High dependability in VSC-MTDC networks • Dynamic adaptation to network conditions • No need for fast communication. 	<ul style="list-style-type: none"> • Increased complexity in developing adaptive time-graded control method. 	[88]

V. FREQUENCY CONTROL METHODS

The operation of any electrical system is strongly reliant on sustaining both frequency and voltage. The importance of frequency can be found in its role in balancing supply and demand, ensuring that the power generated equals the electricity consumed. It's crucial to promptly address any disparity between generation and load to ensure system stability. Large variances can cause serious damage to facilities, emphasizing the significance of frequency regulation [89]-[90]-[91]-[92]. Aquib et al. in [93] proposed a well-established method that serves as the foundation for stable power system functioning. In AC grids, frequency regulation is accomplished using frequency droop, which serves as a global measure to quickly balance generation and demand [94]. Several other research conducted in [94], [95] address the concern of VSC active power. Kabsha et al. [96] implemented an adaptive control tactic for the support of frequency employing a multi-terminal HVDC system connected with offshore wind power generations. This enables wind farms to engage in frequency control activities while also offering inertia support to the grid. After the voltage reaches a death zone limit, the wind turbines will change their speed in order to change the mechanical power, hence implementing frequency regulation. The authors in [97] proposed an adaptive frequency control based on VSC-HVDC system for asynchronous grid Interconnection. The droop gain change adaptively as following:

$$K_{fv,i}^* = K_{GC,i} \cdot \left(S_i \cdot \frac{\alpha_i - |\Delta V_{dcon,i}|}{\beta_i - |\Delta f_{on,i}|} \right) \quad (10)$$

Where is $K_{fv,i}^*$ is the adaptive droop coefficient, $K_{GC,i}$ is the fixed coefficient to comply with GCRs, S_i is a factor to comply with GCRs, α_i and β_i is maximum allowable voltage and frequency fluctuation set by the operator respectively, and $\Delta V_{dcon,i}$ and $\Delta f_{on,i}$ is the voltage and frequency variation respectively.

Similarly, the authors in [98] proposed a double-layered droop control (DLDC) for frequency restoration. In this proposed scheme, the secondary distributed droop layer takes the role of restoring the system frequency to its nominal value and generating a new voltage and frequency input for the primary droop. Another article [99] proposed inertia emulation and fast frequency-droop (IEFF) converter is designed to mimic a synchronous generator, ensuring constant power. The authors in [100] suggested an approach of rapid frequency control for using Battery Energy Storage System (BESS) to minimize instantaneous variation by improving the inertia. The BESS role is to store the excess energy in low demand and release it in time of high demand. In [101], the authors introduced a method based on dynamic converter current regulation to operate within specified limits. This method utilizes a control structure consisting of three layers: an outer control loop for coordinated generation, dynamic current modulation to adjust converter currents based on frequency deviations in the interconnected grid, and an inner current control loop to generate reference converter voltage. Table 3 represents the comparison for frequency control methods.

Table 3 Comparison of frequency control methods

Control method	Advantages	Disadvantages	Ref
Frequency droop	<ul style="list-style-type: none"> • Enhance the operation of frequency support. 	<ul style="list-style-type: none"> • Lack of error free between the MTDC in AC asynchronous system 	[94]
Adaptive frequency control	<ul style="list-style-type: none"> • Comply with GCR code, staple 	<ul style="list-style-type: none"> • Have a fixed value put by the operator 	[96]
Primary frequency regulation control [98]	<ul style="list-style-type: none"> • It uses voltage and speed of turbine to control the frequency, great inertial response, reliable and stable 	<ul style="list-style-type: none"> • Suffer from frequency deviation 	[97]
Double-layered droop control	<ul style="list-style-type: none"> • Great for restoring frequency after disturbance • Offer seamless transition from mi mode to grid connected mode 	<ul style="list-style-type: none"> • To restore the frequency, the controller needs previous values as references to function effectively. They employed a predictive controller to address this issue. 	[98]
Inertia emulation and fast frequency-droop	<ul style="list-style-type: none"> • Great inertia • Stable • Reliable • No communication needed 	<ul style="list-style-type: none"> • Solely concentrates on the point-to-point VSC-HVDC configuration. 	[99]
Fast frequency control	<ul style="list-style-type: none"> • Minimize the deviation, • Improve the inertia. 	<ul style="list-style-type: none"> • Harmonic distortion 	[100]

-
- Quick Restoration Frequency • Ability to operate above the rated limit. • Expensive to perform regular backups and ensure prompt restoration in terms of infrastructure, labor, and storage. [101]
-

VI. CURRENT CHALLENGES, THEIR SOLUTIONS AND FUTURE DIRECTION

Power sharing control in MT-HVDC systems brings a number of challenges, but there are strategies and solutions available to address them. Some of the significant issues and their solutions are given below:

A. COMPLEX CONTROL ORGANIZATION

Controlling several converters in a multi-terminal HVDC system can be difficult. Synchronizing the control systems of each converter is critical for balanced power distribution and grid stability [102].

- **Solution:** Use advanced control algorithms and communication networks to enable real-time data interchange and coordinated terminal control. Model predictive control and distributed control are two strategies that can improve coordination.

B. VARIATIONS IN DC LINK VOLTAGE

Variations in DC link voltage can have an impact on power sharing and system stability and are frequently caused by changes in power generation or demand.

- **Solution:** Implement voltage control algorithms to maintain a consistent DC link voltage. Use DC voltage control systems that react to variations in power flow, such as droop control or supplemental voltage control loops.

C. POWER OSCILLATIONS

Power oscillations in multi-terminal HVDC systems can cause instability owing to power distribution imbalances if left unmanaged.

- **Solution:** Use auxiliary control methods, such as virtual inertia, damping control, or the deployment of energy storage devices, to moderate power oscillations.

D. COMMUNICATION AND SYNCHRONIZATION

Reliable communication between terminals is critical for successful power sharing control, but creating such infrastructure can be difficult, particularly in remote or offshore locations.

Synchronization serves as the keystone in both MTDC systems and AC systems, playing a pivotal role in their individual functionality as well as their interconnection. Within MTDC systems, synchronization ensures harmonious coordination among converters across different terminals, aligning voltages and frequencies along DC links. This alignment is instrumental in maintaining stability, facilitating efficient power flow control, and enabling effective fault management. Similarly, in AC systems, synchronization ensures that generators, transformers, and loads operate at a consistent frequency and phase, vital for grid stability and power quality [102]. When MTDC and AC

systems intersect, synchronization becomes even more critical. It facilitates seamless operation by ensuring that converters in the MTDC system synchronize with the AC grid, enabling smooth power exchange without causing disruptions. However, the synchronization of MTDC systems and AC systems, particularly in their interconnected state, presents a host of challenges. In MTDC systems, one significant challenge arises from the need to maintain synchronous operation across terminals, each potentially using different converter technologies or operating conditions. Coordinating these converters to ensure voltage and frequency alignment requires sophisticated control algorithms and communication systems. Additionally, as MTDC systems often span vast distances, delays in communication between terminals can disrupt synchronization efforts, potentially leading to instability. In AC systems, challenges primarily stem from the inherent complexities of maintaining synchronization across multiple generators, transformers, and loads dispersed throughout the grid. Factors such as generator inertia, varying load demand, and unforeseen disturbances pose significant hurdles to achieving and sustaining synchronization. When MTDC and AC systems are interconnected, the challenges multiply. Ensuring seamless synchronization between the two systems demands intricate control strategies that account for differences in voltage levels, frequency regulations, and response times between AC and DC components. Moreover, the dynamic nature of power exchange between these systems necessitates robust synchronization mechanisms capable of swiftly adapting to fluctuations in demand and generation [103].

- **Solution:** Use robust communication protocols such as IEC 61850 and high-speed, low-latency networks. As backup options, use redundant communication channels and local controllers to improve system resilience.

Addressing the challenges of synchronization in MTDC systems and AC systems, particularly in their interconnected state, requires a multifaceted approach encompassing technological innovations, advanced control strategies, and enhanced communication infrastructure. In MTDC systems, advancements in converter technology, such as the use of VSCs with advanced control algorithms, enable more precise voltage and frequency regulation across terminals. Improved communication networks with low latency and high reliability play a crucial role in enabling coordinated control actions between terminals, mitigating synchronization challenges arising from communication delays. In AC systems, the integration of smart grid technologies enables better coordination among generators and loads, enhancing grid stability and resilience to disturbances. Advanced control strategies, such as predictive control and MPC, offer finer control over generator output and grid parameters, aiding in maintaining synchronization under varying operating conditions. When MTDC and AC systems are

interconnected, innovative solutions such as hybrid AC/DC control architectures and coordinated control schemes optimize power flow and voltage stability, ensuring seamless synchronization between the two systems. Furthermore, ongoing research into emerging technologies like grid-forming converters and advanced energy storage systems holds promise for further enhancing synchronization capabilities and overall system performance [103].

E. CYBERSECURITY

Because multi-terminal HVDC systems rely on digital communication and control systems, cybersecurity is a key concern.

- **Solution:** Implement robust cybersecurity safeguards such as encryption protocols, firewalls, and intrusion detection systems to protect communication networks and control systems from cyberattacks.

There are various new trends and probable future developments in the field of power sharing control for multi-terminal High Voltage Direct Current (HVDC) systems. The following are the major trends in this field:

- A new development is the integration of voltage source converters (VSC) with multi-level modular converters (MMC). The goal of future research will be to harness the complimentary benefits of these technologies by combining them in the best possible way.
- A significant development is the creation of sophisticated control algorithms, such as predictive control, model-based control, and machine learning-based control. These algorithms have the potential to increase grid stability and power sharing accuracy.
- To enhance system resilience and reliability, the development of fault-tolerant and self-healing control techniques will be a critical research focus. This includes the real-time detection and isolation of failures, as well as the autonomous reconfiguration of the system.
- With the increasing relevance of renewable energy sources, future research will concentrate on improving grid integration of renewable generation within multi-terminal systems, such as offshore wind and solar power.
- A rapidly emerging research area is the integration of energy storage systems into multi-terminal HVDC networks which plays a key role within MT systems by enhancing grid quality, stability, and lowering peak demand.

VII. CONCLUSION

An extensive analysis of power distribution control in multi-terminal HVDC systems is presented in this study, with particular attention to MMC, VSC, and hybrid configurations. Power allocation and system stability are greatly enhanced by control techniques such as model predictive control and distributed control. A hybrid setup that combines VSC, LCC, and MMC technologies results in

improved control coordination, improved voltage quality, enhanced redundancy, and scalability. These hybrid systems are adaptable and suitable for a wide range of grid applications. Multi-terminal HVDC systems with power-sharing controls are extremely useful for integrating renewable energy sources into the grid. The importance of their role in connecting offshore wind farms, solar arrays, and other renewable energy locations to load centers is highlighted in the article. Furthermore, power sharing regulation is critical for guaranteeing grid stability and resilience. Coordination of control across numerous terminals offers efficient power distribution, fault tolerance, and fast failure recovery. This study also focuses on how MT-HVDC systems with VSC, MMC, or hybrid designs contribute to efficient long-distance power transmission, lower transmission losses, and alignment with sustainability goals by minimizing environmental effect. This review paper also discusses the issues and possible solutions for power sharing control in MT-HVDC systems, as well as the future research directions.

REFERENCES

- [1] Hertem, V.D., Gomis-Bellmunt, O. and Liang, J. (2016) HVDC grids: For offshore and supergrid of the future. Chichester, West Sussex: Wiley Blackwell.
- [2] N. R. Watson and J. D. Watson, "An overview of HVDC technology," *Energies*, vol. 13, no. 17. MDPI AG, Sep. 01, 2020. doi: 10.3390/en13174342.
- [3] O. Heyman, L. Weimers, and M.-L. Bohl, "HVDC-A key solution in future transmission systems."
- [4] J. Grant, "Review of HVDC technology, applications and future prospects," *Science Direct*, 2017.
- [5] A. Stan, S. Costinaş, and G. Ion, "Overview and Assessment of HVDC Current Applications and Future Trends," *Energies*, vol. 15, no. 3. MDPI, Feb. 01, 2022. doi: 10.3390/en15031193.
- [6] X. Lu, J. M. Guerrero, K. Sun, and J. C. Vasquez, "An Improved Droop Control Method for DC Microgrids Based on Low Bandwidth Communication With DC Bus Voltage Restoration and Enhanced Current Sharing Accuracy," *IEEE Trans Power Electron*, vol. 29, no. 4, pp. 1800–1812, Apr. 2014, doi: 10.1109/TPEL.2013.2266419.
- [7] F. S. Al-Ismail, "DC Microgrid Planning, Operation, and Control: A Comprehensive Review," *IEEE Access*, vol. 9, pp. 36154–36172, 2021, doi: 10.1109/ACCESS.2021.3062840.
- [8] C. B. Robledo, V. Oldenbroek, F. Abbruzzese, and A. J. M. van Wijk, "Integrating a hydrogen fuel cell electric vehicle with vehicle-to-grid technology, photovoltaic power and a residential building," *Appl Energy*, vol. 215, pp. 615–629, Apr. 2018, doi: 10.1016/j.apenergy.2018.02.038.
- [9] A. El-Shahat and S. Sumaiya, "DC-microgrid system design, control, and analysis," *Electronics (Switzerland)*, vol. 8, no. 2, Feb. 2019, doi: 10.3390/electronics8020124.
- [10] A. Abhishek, A. Ranjan, S. Devassy, B. Kumar Verma, S. K. Ram, and A. K. Dhakar, "Review of hierarchical control strategies for DC microgrid," *IET Renewable Power Generation*, vol. 14, no. 10. John Wiley and Sons Inc, pp. 1631–1640, Jul. 01, 2020. doi: 10.1049/iet-rpg.2019.1136.
- [11] O. M. K. K. Nanayakkara, A. D. Rajapakse, and R. Wachal, "Traveling-Wave-Based Line Fault Location in Star-Connected Multiterminal HVDC Systems," *IEEE Transactions on Power Delivery*, vol. 27, no. 4, pp. 2286–2294, Oct. 2012, doi: 10.1109/TPWRD.2012.2202405.
- [12] Abu-Elanien, A.E.B., Elserougi, A.A. High frequency-based protection algorithm for meshed MTDC systems. *Electr Eng* 104, 3313–3324 (2022). <https://doi.org/10.1007/s00202-022-01555-y>.

- [13] M. A. Abdelwahed and E. F. El-Saadany, "Power Sharing Control Strategy of Multiterminal VSC-HVDC Transmission Systems Utilizing Adaptive Voltage Droop," in *IEEE Transactions on Sustainable Energy*, vol. 8, no. 2, pp. 605–615, April 2017, doi: 10.1109/TSTE.2016.2614223.
- [14] J. Deng et al., "System topologies, key operation and control technologies for offshore wind power transmission based on HVDC," in *18th International Conference on AC and DC Power Transmission (ACDC 2022)*, Institution of Engineering and Technology, 2022, pp. 767–774, doi: 10.1049/icp.2022.1286.
- [15] H. Alrajhi, "An Adaptive Wireless Power Sharing Control for Multiterminal HVDC," *Computer Systems Science and Engineering*, vol. 45, no. 1, pp. 117–129, 2023, doi: 10.32604/csse.2023.022464.
- [16] R. Muzzammel, "Traveling Waves-Based Method for Fault Estimation in HVDC Transmission System," *Energies (Basel)*, vol. 12, no. 19, p. 3614, Sep. 2019, doi: 10.3390/en12193614.
- [17] Z. Wang, J. He, Y. Xu, and F. Zhang, "Distributed Control of VSC-MTDC Systems Considering Tradeoff Between Voltage Regulation and Power Sharing," *IEEE Transactions on Power Systems*, vol. 35, no. 3, pp. 1812–1821, May 2020, doi: 10.1109/TPWRS.2019.2953044.
- [18] T. M. Haileselassie, "Control, Dynamics and Operation of Multi-terminal VSC-HVDC Transmission Systems," ntnuopen.ntnu.no, 2012. <http://hdl.handle.net/11250/257409>
- [19] R. H. Chandio et al., "Control and protection of MMC-based HVDC systems: A review," *Energy Reports*, vol. 9, pp. 1571–1588, Dec. 2023, doi: 10.1016/j.egy.2022.12.056.
- [20] L. Zhang et al., "Modeling, control, and protection of modular multilevel converter-based multi-terminal HVDC systems: A review," *CSEE Journal of Power and Energy Systems*, vol. 3, no. 4, pp. 340–352, Dec. 2017, doi: 10.17775/CSEEJPES.2017.00440.
- [21] A. Yadav, S. N. Singh, and S. P. Das, "Modular multi-level converter topologies: Present status and key challenges," in *2017 4th IEEE Uttar Pradesh Section International Conference on Electrical, Computer and Electronics (UPCON)*, IEEE, Oct. 2017, pp. 280–288, doi: 10.1109/UPCON.2017.8251061.
- [22] Zhu, J.; Wei, T.; Huo, Q.; Yin, J. A Full-bridge Director Switches based Multilevel Converter with DC Fault Blocking Capability and Its Predictive Control Strategy. *Energies* 2019, 12, 91. <https://doi.org/10.3390/en12010091>
- [23] Li, W.; Li, G.; Zeng, R.; Ni, K.; Hu, Y.; Wen, H. The Fault Detection, Localization, and Tolerant Operation of Modular Multilevel Converters with an Insulated Gate Bipolar Transistor (IGBT) Open Circuit Fault. *Energies* 2018, 11, 837. <https://doi.org/10.3390/en11040837>
- [24] C. Guo, Z. Yin, C. Zhao, and R. Iravani, "Small-signal dynamics of hybrid LCC-VSC HVDC systems," *International Journal of Electrical Power and Energy Systems*, vol. 98, pp. 362–372, Jun. 2018, doi: 10.1016/j.ijepes.2017.12.010.
- [25] M. Cheah-Mane, J. Song, R. Ferrer-San-Jose, E. Prieto-Araujo and O. Gomis-Bellmunt, "Analysis of hybrid LCC-VSC HVDC transmission system configurations," *15th IET International Conference on AC and DC Power Transmission (ACDC 2019)*, Coventry, UK, 2019, pp. 1-6, doi: 10.1049/cp.2019.0071.
- [26] H. Xiao, K. Sun, J. Pan, Y. Li, and Y. Liu, "Review of hybrid HVDC systems combining line communicated converter and voltage source converter," *International Journal of Electrical Power & Energy Systems*, vol. 129, p. 106713, Jul. 2021, doi: 10.1016/j.ijepes.2020.106713.
- [27] H. R. Wickramasinghe and G. Konstantinou, "Interoperability of modular VSC topologies in Multi-converter multiterminal DC systems," *Electric Power Systems Research*, vol. 196, Jul. 2021, doi: 10.1016/j.epsr.2021.107225.
- [28] M. Cheah-Mane, Jie Song, R. Ferrer-San-Jose, E. Prieto-Araujo, and O. GomisBellmunt, "Analysis of Hybrid LCC-VSC HVDC Transmission System Configurations," in *15th IET International Conference on AC and DC Power Transmission (ACDC 2019)*, Institution of Engineering and Technology, 2019, pp. 71 (6 pp.)-71 (6 pp.). doi: 10.1049/cp.2019.0071.
- [29] L. Zhang, K. Chen, S. Chi, L. Lyu, and G. Cai, "The Hierarchical Control Algorithm for DC microgrid based on the improved droop control of Fuzzy Logic," *Energies*, vol. 12, no. 15, p. 2995, 2019, doi:10.3390/en12152995.
- [30] [L. Yu, R. Li, and L. Xu, "Hierarchical control of offshore wind farm connected by parallel diode-rectifier-based HVDC and HVAC links," *IET Renewable Power Generation*, vol. 13, no. 9, pp. 1493–1502, Jul. 2019, doi: 10.1049/iet-rpg.2019.0033.
- [31] X. Li, L. Guo, C. Hong, Y. Zhang, Y. W. Li, and C. Wang, "Hierarchical Control of Multiterminal DC Grids for Large-Scale Renewable Energy Integration," *IEEE Trans Sustain Energy*, vol. 9, no. 3, pp. 1448–1457, Jul. 2018, doi: 10.1109/TSTE.2018.2789465.
- [32] S. K. Sahoo, A. K. Sinha, and N. K. Kishore, "Control Techniques in AC, DC, and Hybrid AC-DC Microgrid: A Review," *IEEE Journal of Emerging and Selected Topics in Power Electronics*, vol. 6, no. 2, Institute of Electrical and Electronics Engineers Inc., pp. 738–759, Jun. 01, 2018, doi: 10.1109/JESTPE.2017.2786588.
- [33] H. A. Alsiraji, A. A. A. Radwan, and R. El-Shatshat, "Modelling and analysis of a synchronous machine-emulated active interturing converter in hybrid AC/DC microgrids," *IET Generation, Transmission and Distribution*, vol. 12, no. 11, pp. 2539–2548, Jun. 2018, doi: 10.1049/iet-gtd.2017.0734.
- [34] H. A. E. Elhassaneen and T. Tsuji, "Cooperative Decentralized Tertiary Based Control of DC Microgrid with Renewable Distributed Generation," in *2019 IEEE 3rd International Conference on DC Microgrids, ICDCM 2019*, Institute of Electrical and Electronics Engineers Inc., May 2019, doi: 10.1109/ICDCM45535.2019.9232871.
- [35] D. E. Olivares et al., "Trends in microgrid control," *IEEE Trans Smart Grid*, vol. 5, no. 4, pp. 1905–1919, 2014, doi: 10.1109/TSG.2013.2295514.
- [36] A. M. Shotorbani, Y. Zhang and L. Wang, "Secondary Control of a Multi-Terminal HVDC Grid Using a Consensus-Based Distributed Scheme," *2019 IEEE Canadian Conference of Electrical and Computer Engineering (CCECE)*, Edmonton, AB, Canada, 2019, pp. 1-4, doi: 10.1109/CCECE.2019.8861531.
- [37] M. Yuan, Y. Fu, Y. Mi, Z. Li, and C. Wang, "Hierarchical control of DC microgrid with dynamical load power sharing," *Appl Energy*, vol. 239, pp. 1–11, Apr. 2019, doi: 10.1016/j.apenergy.2019.01.081.
- [38] S. Liu, R. Liu, J. Zheng, and X. Liu, "Predictive function control in tertiary level for power flow management of DC microgrid clusters," *Electron Lett*, vol. 56, no. 13, pp. 675–676, Jun. 2020, doi: 10.1049/el.2020.0108.
- [39] J. Hu, J. Duan, H. Ma, and M. Y. Chow, "Distributed Adaptive Droop Control for Optimal Power Dispatch in DC Microgrid," *IEEE Transactions on Industrial Electronics*, vol. 65, no. 1, pp. 778–789, Jan. 2018, doi: 10.1109/TIE.2017.2698425.
- [40] O. D. Montoya, W. Gil-González, F. M. Serra, C. H. De Angelo, and J. C. Hernández, "Global Optimal Stabilization of MT-HVDC systems: Inverse Optimal Control Approach," *Electronics*, vol. 10, no. 22, p. 2819, 2021, doi:10.3390/electronics10222819
- [41] F. A. Chachar et al., "Hierarchical Control Implementation for Meshed AC/Multi-Terminal DC Grids with Offshore Windfarms Integration," *IEEE Access*, vol. 7, pp. 142233–142245, 2019, doi: 10.1109/ACCESS.2019.2944718.
- [42] S.-W. Lee and B.-H. Cho, "Master-Slave Based Hierarchical Control for a Small Power DC-Distributed Microgrid System with a Storage Device," *Energies (Basel)*, vol. 9, no. 11, p. 880, Oct. 2016, doi: 10.3390/en9110880.
- [43] Q. Yang, J. Shen, J. Li, H. He, Z. Wei, and P. Iqic, "An Improved Adaptive Coordination Control of Wind Integrated Multi-Terminal HVdc System," *IEEE Trans Power Electron*, vol. 38, no. 4, pp. 5490–5499, Apr. 2023, doi: 10.1109/TPEL.2022.3228949.
- [44] A. Raza et al., "Multi-Objective Optimization of VSC Stations in Multi-Terminal VSC-HVdc Grids, Based on PSO," *IEEE Access*, vol. 6, pp. 62995–63004, 2018, doi: 10.1109/ACCESS.2018.2875972.
- [45] Y. -K. Chen, Y. -C. Wu, C. -C. Song and Y. -S. Chen, "Design and Implementation of Energy Management System With Fuzzy Control for DC Microgrid Systems," in *IEEE Transactions on Power Electronics*, vol. 28, no. 4, pp. 1563–1570, April 2013, doi: 10.1109/TPEL.2012.2210446.
- [46] J. C. Pena-Aguirre, A.-I. Barranco-Gutierrez, J. A. Padilla-Medina, A. Espinosa-Calderon, and F. J. Perez-Pinal, "Fuzzy Logic Power

- Management Strategy for a Residential DC-Microgrid,” IEEE Access, vol. 8, pp. 116733–116743, 2020, doi: 10.1109/ACCESS.2020.3004611.
- [47] R. R. Deshmukh, M. S. Ballal, and H. M. Suryawanshi, “A Fuzzy Logic Based Supervisory Control for Power Management in Multibus DC Microgrid,” IEEE Trans Ind Appl, vol. 56, no. 6, pp. 6174–6185, Nov. 2020, doi: 10.1109/TIA.2020.3012415.
- [48] X. Chen, L. Wang, H. Sun, and Y. Chen, “Fuzzy Logic Based Adaptive Droop Control in Multiterminal HVDC for Wind Power Integration,” IEEE Transactions on Energy Conversion, vol. 32, no. 3, pp. 1200–1208, Sep. 2017, doi: 10.1109/TEC.2017.2697967.
- [49] A. S. Kumar and B. P. Padhy, “Communication-Free based Decoupled DC-Voltage and Frequency Control in the Multi-Terminal HVDC (MTDC) Grids,” in IEEE Power and Energy Society General Meeting, IEEE Computer Society, 2021, doi: 10.1109/PESGM46819.2021.9637873.
- [50] Y. Qian, Z. Wang and Y. Deng, “An Improved Droop Control Method for VSC- MTDC Considering Power Mismatch Allocation,” 2019 4th IEEE Workshop on the Electronic Grid (eGRID), Xiamen, China, 2019, pp. 1–6, doi: 10.1109/eGRID48402.2019.9092729.
- [51] S. D. Tavakoli, E. Sanchez-Sanchez, E. Prieto-Araujo, and O. Gomis-Bellmunt, “DC Voltage Droop Control Design for MMC-Based Multiterminal HVDC Grids,” IEEE Transactions on Power Delivery, vol. 35, no. 5, pp. 2414–2424, Oct. 2020, doi: 10.1109/TPWRD.2020.2967881.
- [52] J. So, H. Shin, T. N. Tran, and Y.-J. Choi, “Decentralized Cooperative Active Power Control for Small-Scale Grids with High Renewable Penetration through VSC-HVDC,” *Sustainability*, vol. 14, no. 15, p. 9539, Aug. 2022, doi: 10.3390/su14159539.
- [53] A. Teymouri, P. M. Shabestari, M. Mousavi and A. Mehrizi-Sani, “Feedforward Accurate Power Sharing and Voltage Control for Multi-Terminal HVDC Grids,” IECON 2019 - 45th Annual Conference of the IEEE Industrial Electronics Society, Lisbon, Portugal, 2019, pp. 4819–4824, doi: 10.1109/IECON.2019.8927091.
- [54] M. Mehra, M. Sharifzadeh, M. Babaie and K. Al-Haddad, “Power Sharing Management of a PEC9-based Microgrid by Feedback-Feedforward Control Strategy,” 2020 IEEE 29th International Symposium on Industrial Electronics (ISIE), Delft, Netherlands, 2020, pp. 1062–1067, doi: 10.1109/ISIE45063.2020.9152380.
- [55] A. F. Habibullah and K. H. Kim, “Decentralized Power Management of DC Microgrid Based on Adaptive Droop Control With Constant Voltage Regulation,” IEEE Access, vol. 10, pp. 129490–129504, 2022, doi: 10.1109/ACCESS.2022.3228703.
- [56] N. Chaudhuri and C. Balarko, “Adaptive droop control for effective power sharing in multi-terminal DC (MTDC) grids,” IEEE Transactions on Power Systems, vol. 28, no. 1, pp. 21–29, 2013.
- [57] J. Wang, Z. Liu, J. Liu, and T. Wu, “A Mode Switching-Based Decentralized Secondary Control for Microgrids With Hybrid Droop and Master-Slave Structure,” IEEE Open Journal of Power Electronics, vol. 3, pp. 334–347, 2022, doi: 10.1109/OJPEL.2022.3176023.
- [58] X. Liu, X. Zhang, F. Guo, G. Xiao, and P. Wang, “Decentralized Secondary Frequency Restoration and Power Sharing Control for MTDC Transmission Systems,” in IECON Proceedings (Industrial Electronics Conference), IEEE Computer Society, Oct. 2020, pp. 1567–1572, doi: 10.1109/IECON43393.2020.9254605.
- [59] S. Lotfifard, D. Nojavanzadeh, Z. Liu, A. Saberi, and A. A. Stoorvogel, “Distributed Cooperative Voltage Control of Multiterminal High-Voltage DC Systems,” IEEE Syst J, vol. 16, no. 1, pp. 176–184, Mar. 2022, doi: 10.1109/JSYST.2020.3022758.
- [60] J. Kumar, A. Agarwal, and V. Agarwal, “A review on overall control of DC microgrids,” Journal of Energy Storage, vol. 21, Elsevier Ltd, pp. 113–138, Feb. 01, 2019, doi: 10.1016/j.est.2018.11.013.
- [61] F. D. Bianchi, J. L. Domínguez-García, and O. Gomis-Bellmunt, “Control of multi-terminal HVDC networks towards wind power integration: A review,” *Renewable and Sustainable Energy Reviews*, vol. 55, pp. 1055–1068, Mar. 2016, doi: 10.1016/j.rser.2015.11.024.
- [62] Y. Tripathy and B. Tyagi, “Multi-agent distributed control and power sharing between microgrid DERs,” in 2020 21st National Power Systems Conference, NPSC 2020, Institute of Electrical and Electronics Engineers Inc., Dec. 2020, doi: 10.1109/NPSC49263.2020.9331880.
- [63] Y. Guo, H. Gao, and Q. Wu, “Distributed cooperative voltage control of wind farms based on consensus protocol,” International Journal of Electrical Power and Energy Systems, vol. 104, pp. 593–602, Jan. 2019, doi: 10.1016/j.ijepes.2018.07.030.
- [64] W. Wang, X. Yin, Y. Cao, L. Jiang, and Y. Li, “A Distributed Cooperative Control Based on Consensus Protocol for VSC-MTDC Systems,” IEEE Transactions on Power Systems, vol. 36, no. 4, pp. 2877–2890, Jul. 2021, doi: 10.1109/TPWRS.2021.3051770.
- [65] Z. J. Hu, Z. W. Liu, C. Li, T. Huang, and X. Hu, “A model-free distributed cooperative frequency control strategy for MT-HVDC systems using reinforcement learning method,” J Franklin Inst, vol. 358, no. 13, pp. 6490–6507, Sep. 2021, doi: 10.1016/j.jfranklin.2021.06.011.
- [66] Y. Zhang, A. M. Shotorbani, L. Wang and W. Li, “Distributed Voltage Regulation and Automatic Power Sharing in Multi-Terminal HVDC Grids,” in IEEE Transactions on Power Systems, vol. 35, no. 5, pp. 3739–3752, Sept. 2020, doi: 10.1109/TPWRS.2020.2986168.
- [67] J. Zhou et al., “Distributed Power Sharing Control for Islanded Single-/Three-Phase Microgrids with Admissible Voltage and Energy Storage Constraints,” IEEE Trans Smart Grid, vol. 12, no. 4, pp. 2760–2775, Jul. 2021, doi: 10.1109/TSG.2021.3057899.
- [68] Z. Kang, Z. Zhang, S. Wang, and R. Yin, “A New Adaptive DC Voltage Droop Control for Hybrid Cascaded HVDC Transmission System,” in 2022 4th Asia Energy and Electrical Engineering Symposium, AEEES 2022, Institute of Electrical and Electronics Engineers Inc., 2022, pp. 536–540, doi: 10.1109/AEEES54426.2022.9759756.
- [69] H. Alyami, “Master-Slave with Droop Control for MTDC Grids,” in 2020 2nd IEEE International Conference on Industrial Electronics for Sustainable Energy Systems (IESES), IEEE, Sep. 2020, pp. 119–124, doi: 10.1109/IESES45645.2020.9210658.
- [70] X. Xie, X. Quan, Z. Wu, X. Cao, X. Dou, and Q. Hu, “Adaptive Master-Slave Control Strategy for Medium Voltage DC Distribution Systems Based on a Novel Nonlinear Droop Controller,” IEEE Trans Smart Grid, vol. 12, no. 6, pp. 4765–4777, Nov. 2021, doi: 10.1109/TSG.2021.3104413.
- [71] Y. Zhang, A. M. Shotorbani, L. Wang and W. Li, “A Combined Hierarchical and Autonomous DC Grid Control for Proportional Power Sharing With Minimized Voltage Variation and Transmission Loss,” in IEEE Transactions on Power Delivery, vol. 37, no. 4, pp. 3213–3224, Aug. 2022, doi: 10.1109/TPWRD.2021.3125254.
- [72] Y. Zhang, L. Wang and W. Li, “Autonomous DC Line Power Flow Regulation Using Adaptive Droop Control in HVDC Grid,” in IEEE Transactions on Power Delivery, vol. 36, no. 6, pp. 3550–3560, Dec. 2021, doi: 10.1109/TPWRD.2020.3044978.
- [73] B. Ayalew, M. S. E. Moursi and E. F. El-Saadany, “Enhanced DC Voltage Regulation and Transient Response for Multi-Terminal VSC-HVDC System Using Direct Power Control,” in IEEE Transactions on Power Systems, vol. 37, no. 4, pp. 2538–2548, July 2022, doi: 10.1109/TPWRS.2021.3126437.
- [74] H. Chen and B. Gao, *Nonlinear Estimation and Control of Automotive Drivetrains*. Berlin, Heidelberg: Springer Berlin Heidelberg, 2014, doi: 10.1007/978-3-642-41572-2.
- [75] S. Mariétoz, A. Fuchs and M. Morari, “A VSC-HVDC Decentralized Model Predictive Control Scheme for Fast Power Tracking,” in IEEE Transactions on Power Delivery, vol. 29, no. 1, pp. 462–471, Feb. 2014, doi: 10.1109/TPWRD.2013.2265277.
- [76] H. Zhao, Q. Wu, J. Wang, Z. Liu, M. Shahidehpour and Y. Xue, “Combined Active and Reactive Power Control of Wind Farms Based on Model Predictive Control,” in IEEE Transactions on Energy Conversion, vol. 32, no. 3, pp. 1177–1187, Sept. 2017, doi: 10.1109/TEC.2017.2654271.
- [77] H. Zhao, Q. Wu, Q. Guo, H. Sun, S. Huang, and Y. Xue, “Coordinated voltage control of a wind farm based on model predictive control,” IEEE Trans Sustain Energy, vol. 7, no. 4, pp. 1440–1451, Oct. 2016, doi: 10.1109/TSTE.2016.2555398.
- [78] A. Bouzidi, S. Barkat, A. Akka, and M. L. Bendaas, “Sequential Model Predictive Control for five-level MMC-based multi-terminal

- HVDC systems,” *Journal of Power Electronics*, vol. 23, no. 10, pp. 1507–1516, 2023. doi:10.1007/s43236-023-00651-x
- [79] G. Zhou and W. Ma, “Model Predictive Control-based Coordinated Control Strategy for VSC-MTDC Systems,” 2019 22nd International Conference on Electrical Machines and Systems (ICEMS), Harbin, China, 2019, pp. 1-5, doi: 10.1109/ICEMS.2019.8921884.
- [80] Y. Guo, H. Gao, H. Xing, Q. Wu, and Z. Lin, “Decentralized Coordinated Voltage Control for VSC-HVDC Connected Wind Farms Based on ADMM,” *IEEE Trans Sustain Energy*, vol. 10, no. 2, pp. 800–810, Apr. 2019, doi: 10.1109/TSTE.2018.2848467.
- [81] Z. Zhang, P. Kou, Y. Zhang, and D. Liang, “Distributed model predictive control of all-dc offshore wind farm for short-term frequency support,” *IET Renewable Power Generation*, vol. 17, no. 2, pp. 458–479, Feb. 2023, doi: 10.1049/rpg2.12609.
- [82] Annamalai, A. et al. (2015) A robust navigation technique for integration in the guidance and control of an uninhabited surface vehicle: *The Journal of Navigation*, Cambridge Core. Available at: <https://doi.org/10.1017/S0373463315000065>
- [83] V. T. K. Nguyen, Y. K. Wu, and Q. D. Phan, “Adaptive Droop Control for Compromise between DC Voltage and Frequency in Multi-Terminal HVDC,” *IEEE Access*, vol. 9, pp. 131708–131719, 2021, doi: 10.1109/ACCESS.2021.3114406.
- [84] F. Kamal, H. M. M. Maruf, B. H. Chowdhury and M. Manjrekar, “Power Sharing of Offshore Wind Farm and Onshore Grid in Integrated VSC Controlled Multi-Terminal HVDC System,” 2019 IEEE Power & Energy Society General Meeting (PESGM), Atlanta, GA, USA, 2019, pp. 1-5, doi: 10.1109/PESGM40551.2019.8973579.
- [85] S. Zhang, M. Zhou, and G. Li, “Applying power margin tracking droop control to flexible operation in multi-terminal DC collector systems of renewable generation,” *CSEE Journal of Power and Energy Systems*, vol. 7, no. 6, pp. 1176–1186, Nov. 2021, doi: 10.17775/CSEEJPE.2020.01470.
- [86] S. Song, R. A. McCann, and G. Jang, “Cost-Based Adaptive Droop Control Strategy for VSC-MTDC system,” *IEEE Transactions on Power Systems*, vol. 36, no. 1, pp. 659–669, Jan. 2021, doi: 10.1109/tpwrs.2020.3003589.
- [87] Ambia, MN, Meng, K, Xiao, W, Al-Durra, A & Dong, ZY 2021, 'Adaptive Droop Control of Multi-Terminal HVDC Network for Frequency Regulation and Power Sharing', *IEEE Transactions on Power Systems*, vol. 36, no. 1, 9106838, pp. 566-578. <https://doi.org/10.1109/TPWRS.2020.2999443>
- [88] H. Toodeji and M. Jafari, “An adaptive time-graded control method for VSC-MTDC networks,” *Electric Power Systems Research*, vol. 174, Sep. 2019, doi: 10.1016/j.epr.2019.04.033.
- [89] A. Daraz, “Optimized cascaded controller for frequency stabilization of marine microgrid system,” *Appl Energy*, vol. 350, p. 121774, Nov. 2023, doi: 10.1016/j.apenergy.2023.121774.
- [90] I. A. Khan et al., “Load Frequency Control Using Golden Eagle Optimization for Multi-Area Power System Connected Through AC/HVDC Transmission and Supported With Hybrid Energy Storage Devices,” *IEEE Access*, vol. 11, pp. 44672–44695, 2023, doi: 10.1109/ACCESS.2023.3272836.
- [91] A. Daraz, S. A. Malik, A. Basit, S. Aslam, and G. Zhang, “Modified FOPID Controller for Frequency Regulation of a Hybrid Interconnected System of Conventional and Renewable Energy Sources,” *Fractal and Fractional*, vol. 7, no. 1, p. 89, Jan. 2023, doi: 10.3390/fractalfract7010089.
- [92] Peng Zhang, Amil Daraz, Suheel Abdullah Malik, Chao Sun, Abdul Basit, and Guoqiang Zhang, “Multi-resolution based PID controller for Frequency Regulation of a hybrid power system with multiple interconnected systems,” *Frontiers (Boulder)*, vol. 10, no. 2022, Feb. 2023.
- [93] M. Aquib, N. Parth, S. Doolla and M. C. Chandorkar, “An Adaptive Droop Scheme for Improving Transient and Steady-State Power Sharing Among Distributed Generators in Islanded Microgrids,” in *IEEE Transactions on Industry Applications*, vol. 59, no. 4, pp. 5136–5148, July-Aug. 2023, doi: 10.1109/TIA.2023.3272873.
- [94] Li, Y. et al. (2020) ‘Engineering practices for the integration of large-scale renewable energy VSC-HVDC systems’, *Global Energy Interconnection*, 3(2), pp. 149–157. doi:10.1016/j.gloi.2020.05.007.
- [95] N. Flourentzou, V. G. Agelidis and G. D. Demetriades, “VSC-Based HVDC Power Transmission Systems: An Overview,” in *IEEE Transactions on Power Electronics*, vol. 24, no. 3, pp. 592–602, March 2009, doi: 10.1109/TPEL.2008.2008441.
- [96] J. Chu, Y. Lv, Y. Xu, G. Du, D. Sun, and P. Yu, “Coordinated Control Strategy for Improving Frequency Stability of Offshore Wind Farms Connected to the Grid through MMC - HVDC Transmission,” in 2022 4th Asia Energy and Electrical Engineering Symposium, AEEES 2022, Institute of Electrical and Electronics Engineers Inc., 2022, pp. 354–360, doi: 10.1109/AEEES54426.2022.9759790.
- [97] M. M. Kabsha and Z. H. Rather, “Adaptive Control Strategy for Frequency Support From MTDC Connected Offshore Wind Power Plants,” *IEEE Trans Power Electron*, vol. 38, no. 3, pp. 3981–3991, Mar. 2023, doi: 10.1109/TPEL.2022.3217712.
- [98] S. Patra and M. Basu, “Double-Layered Droop Control-Based Frequency Restoration and Seamless Reconnection of Isolated Neighboring Microgrids for Power Sharing,” *IEEE J Emerg Sel Top Power Electron*, vol. 10, no. 5, pp. 6231–6242, Oct. 2022, doi: 10.1109/JESTPE.2022.3197729.
- [99] J. Zhu et al., “Inertia Emulation and Fast Frequency-Droop Control Strategy of a Point-to-Point VSC-HVdc Transmission System for Asynchronous Grid Interconnection,” *IEEE Trans Power Electron*, vol. 37, no. 6, pp. 6530–6543, Jun. 2022, doi: 10.1109/TPEL.2021.3139960.
- [100] T. Dimbassa, G. Biru, and M. Ghandhari, Analysis of fast frequency control using battery energy storage systems in mitigating impact of photovoltaic penetration in ethiopia-kenya HVDC link, 2023. doi:10.2139/ssrn.4510076
- [101] A. Taneja, R. Saha, and M. Singh, “A Dynamic and Efficient Active Power Support Scheme Using VSC-HVDC System for Quick Frequency Restoration,” *Arab J Sci Eng*, 2023, doi: 10.1007/s13369-023-08130-y.
- [102] I. Bennis et al., “Design, modeling, and validation of grid-forming inverters for frequency synchronization and restoration,” *Energies*, vol. 17, no. 1, p. 59, Dec. 2023. doi:10.3390/en17010059
- [103] H. Alrajhi, “A Novel Synchronization Method for Seamless Microgrid Transitions,” *Arab J Sci Eng*, 2023, doi: <https://doi.org/10.1007/s13369-023-08454-9>.



Hasan K. Alrajhi (M'08–SM'22) received the B.Sc. degree (Hons.) in electrical engineering from the University of Umm Al-Qura, Makkah, Saudi Arabia, in 2009, and the M.Sc. and Ph.D. degrees in electrical power engineering from the University of Waterloo, Ontario, Canada, in 2014 and 2018, respectively. He is currently an associate professor with the Electrical Engineering Department at Umm Al-Qura University, Makkah. His research interests include the following: the dynamics and control of power electronics; AC, DC, and hybrid microgrids; the interconnection of renewable energies; HVDC; and MTDC-VSC.



AMIL DARAZ was born in Pakistan, in 1989. He received the B.E. degree in Electronics Engineering from COMSATS University Islamabad, Pakistan in 2012, the M.S. degree in Power and Control Engineering from International Islamic University Islamabad (IIUI), Pakistan, and Ph.D degree in Electrical Engineering from International Islamic University Islamabad (IIUI), Pakistan. He is currently pursuing his Postdoctoral research at NingboTech University, Ningbo, China. His research interests include control systems, Power system operation and Control, optimization of solving nonlinear problems.



Ahmed Alzahrani is currently pursuing his bachelor degree in Electrical Engineering Department, Umm Al-Qura University, Makkah, Saudi Arabia. His research interests include analog filter design, power electronic control, multi-terminal high voltage DC, and control.

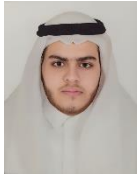

Hisham Babsail is currently pursuing his bachelor degree in Electrical Engineering Department, Umm Al-Qura University, Makkah, Saudi Arabia. His research interests include analog filter design, power electronic control, multi-terminal high voltage DC and control.



Yazeed Alharbi is currently pursuing his bachelor degree in Electrical Engineering Department, Umm Al-Qura University, Makkah, Saudi Arabia. His research interests include analog filter design, power electronic control, multi-terminal high voltage DC and control.



Fahad Alsharif is currently pursuing his bachelor degree in Electrical Engineering Department, Umm Al-Qura University, Makkah, Saudi Arabia. His research interests include analog filter design, power electronic control, multi-terminal high voltage DC and control.



Abdulrahman Alattas is currently pursuing his bachelor degree in Electrical Engineering Department, Umm Al-Qura University, Makkah, Saudi Arabia. His research interests include analog filter design, power electronic control, multi-terminal high voltage DC and control.



Khaled Alshammari received the B.Sc. degree in electrical engineering from the University of Ha'il, Ha'il, Saudi Arabia, in 2015, and the MSc degree in electrical and computer engineering from the University of Waterloo, Ontario, Canada, in 2020. He is currently a specialist instrumentation engineer with Saudi Aramco, Dhahran, Saudi Arabia. His research interests are power electronics, control of MTDC systems, distributed renewable generators, and integration of AC grid with renewable resources.