

RESEARCH ARTICLE

Hardware Evaluation of Cluster-Based Agricultural IoT Network

EMMANUEL EFFAH¹, (Member, IEEE), OUSMANE THIARE², (Member, IEEE),
AND ALEXANDER M. WYGLINSKI³, (Senior Member, IEEE)

¹Department of Computer Science and Engineering, University of Mines and Technology, Tarkwa, Ghana

²Department of Computer Science, Gaston Berger University, Saint-Louis 5005, Senegal

³Department of Electrical and Computer Engineering, Worcester Polytechnic Institute, Worcester, MA 01609, USA

Corresponding author: Emmanuel Effah (ceffah@umat.edu.gh)

This work was supported in part by the International Centre of Insect Physiology and Ecology (icipe)-World Bank Financing under Grant D347-3A, and in part by the World Bank Korea Trust Fund for the Partnership for Skills in Applied Sciences, Engineering and Technology (PASET) Regional Scholarship and Innovation Fund under Grant TF0A8639.

ABSTRACT In this paper, we present a real-world hardware evaluation of a robust, affordable, location-independent, simple, and infrastructure-less cluster-based agricultural Internet of Things (CA-IoT) network based on a commercial off-the-shelf (COTS) Bluetooth Low-Energy (BLE) communication technique and Raspberry Pi module 3 B + (RPI 3 B +) to address global food insecurity caused by climate change and increasing global population via precision farming and greenhouses. Using an engineering design approach, an initial centralized agricultural IoT hardware test-bed was implemented with the aid of BLE, RPi 3 B +, DHT22, STEMMA soil moisture sensors, UM25 meters, and LoPy /low-power Wi-Fi modules, among other devices. This test-bed was adapted and modified after the proposed cluster-based architecture to evaluate the performance of CA-IoT networks. This study provides holistic account of our location-independent CA-IoT solution covering the design and deployment experiences that can serve as a reference document to the agricultural Internet of Things (Agri-IoT) community. Additionally, the proposed solution performed satisfactorily when tested under indoor and outdoor (on-farm) environmental conditions in the USA and Senegal. Unlike existing Agri-IoT test-beds, a sample performance evaluation showed that our context-relevant CA-IoT technology is simple to deploy and manage by inexperienced users and is energy-efficient, location-independent, robust, and task- and size-scalable to provide a rich set of measurements for both educational and commercial purposes.

INDEX TERMS Agricultural IoT (Agri-IoT), bluetooth low-energy (BLE), cluster-based agricultural IoT (CA-IoT), wireless sensor network-based agricultural IoT (WSN-based Agri-IoT).

I. INTRODUCTION

In addition to being time-consuming, labor-intensive, inefficient, and unreliable, the rainfall-dependent traditional farming procedure is no longer dependent on addressing the current food insecurity challenges and the resulting unemployment threats created by the negative impacts of climate change and the increasing global population on agriculture, the biggest global employer [1], [2], [3], [4], [5], [6]. For instance, the countries along the Sahel region of Africa, the focus of this research, have lost their natural

The associate editor coordinating the review of this manuscript and approving it for publication was Oussama Habachi^{id}.

agricultural production seasons due to climate-change-induced drought. The International Monetary Fund's (IMF) statistics on the impact of climate change on food insecurity in Sub Saharan Africa (SSA) in 2022 established that climate change induced drought has contributed 12 percent of SSA's food insecurity [7], and this will double if smart farming is not given the needed research attention. Since 2022, the number of people affected by global food insecurity rose from 135 million in 53 countries in 2019 to 345 million in 82 countries in 2022 [7]. Fortunately, the wireless sensor network-based Agricultural Internet of Things (WSN-based Agri-IoT) technology, the underlying technology for smart or precision farming and greenhouses,

has emerged with promising potential to ensure resource optimization, remote monitoring, and farm automation using sampled data on micro-climatic parameters, physical conditions, livestock locations/conditions, and farm activities via a variety of wirelessly connected electronic devices called sensor nodes (SNs), systems, and platforms. This agricultural Internet of Things (Agri-IoT) technology not only ensures the management of farming processes, resources, and remote monitoring and control (*i.e.*, farm automation), but also improves crop quality and production capacities by ensuring that the right amount of resources such as water, fertilizers, and pesticides are applied at the right time under suitable environmental conditions [4], [5], [8]. This calls for a paradigm shift in farming techniques in Africa, and the most promising game-changer must be robust, affordable, autonomous, and context-relevant Agri-IoT technology that satisfies the critical design expectations presented in Figure 1.

To date, research has revealed that the critical determinant of performance efficiency, cost, operational complexity, communication requirements, and autonomy of WSN-based Agri-IoT networks is the event routing architecture defined by the event routing protocol, of which the cluster-based architecture has emerged with the most promising potential [4], [8], [9]. The core theoretical benefits of the cluster-based architecture in [1], [4], [10], [11], [12], and [13] must be realized in custom-built Agri-IoT networks to address the technical challenges in related benchmarking test-bed solutions in [3], [5], [14], [15], [16], [17], and [18], including the following:

- 1) Power optimization via minimization of intra-SN communication distances and the amount of data transmitted,
- 2) Easier implementation of fault management and self-healing mechanisms,
- 3) Support for densely deployed wireless sensor network (WSN) sublayer,
- 4) Improvement of network maintainability and self-adaptability to turbulent and scalable conditions,
- 5) Implementation of freely available, low-cost, short-range communication standards, such as Bluetooth low-energy (BLE), to achieve a pure infrastructure-less, low-cost, and location-independent real-world WSN-based Agri-IoT, which can be globally significant to all farmers regardless of their technical expertise, farm locations, and economic conditions.

However, the real-world realization of the WSN-based CA-IoT has received inadequate research attention. First, the few existing Agri-IoT test-beds were founded on the operational principles and technologies [19], [20], [21], [22], [23] of the conventional IoT without any context-specific technical considerations of the critical design expectations in Figure 1 [3], [5], [14], [15], [16], [17], [18], [24], [25]. Thus, they are based on fault-vulnerable, inflexible, power-inefficient, and non-scalable centralized, mesh, or graphical routing architectures and location-restricted

communication technologies (*e.g.*, Wi-Fi and cellular-based communication technologies). Consequently, the resulting networks can not achieve the desired performance and users' expectations. In addition, these solutions are unreliable, cost-intensive, location-restricted, based on fixed/wired supporting infrastructure, and too complex to deploy and manage by non-experts. As illustrated in Figure 2, these real-world solutions are context-irrelevant because of their design and operational principles and reliance on high-resource-demanding communication standards (*e.g.*, Wi-Fi, NB-IoT, Zibee, and cellular-based technologies [19], [21], [22], [26]), complex routing architectures (*e.g.*, centralized, flooding, mesh, or graphical [2], [20], [27]), and fixed cellular and electricity access. Overall, these studies were conducted without any in-depth contextual consideration of Africa's unique agricultural setting. For instance, the World Bank's current data on cellular-based telecommunication and electricity coverage in Africa report that more than half (50%) of sub-Saharan Africans lack access to reliable electricity and cellular coverage [28], making these solutions context-irrelevant to the global food basket (Africa).

Second, unlike conventional IoT applications, such as medical IoT, industrial IoT, and vehicular IoT whose designs are constrained by data security, interference, and reliable connectivity, Agri-IoT is compelled to drive on battery power, as well as affordable, simple, energy-efficient, autonomous, and task-scalable SNs. These factors make the architecture, power consumption, cost, self-healing capacity, self-adaptability, associated communication standards, and environmental impact critical design factors to address the associated resource/deployment-induced challenges. Agri-IoT networks are expected to operate autonomously in hostile environments without post-deployment maintenance services. Although the IoT is transformative technology, the agricultural setting is a unique environment in which conventional IoT technologies do not apply. It is not just a matter of applying an IoT to a farm using any IoT design principles in the state-of-the-art [3], [5], [14], [15], [16], [17], [18], as illustrated in Figure 2b. As depicted in Figure 1, Agri-IoT technology has a broader contextualized expectation than conventional IoT.

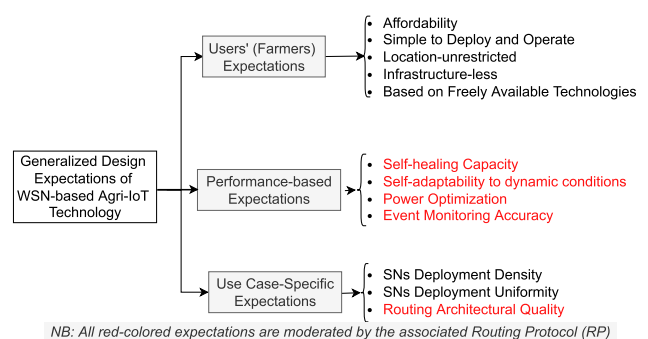

FIGURE 1. Generalized design expectations of a globally significant Agri-IoT technology.

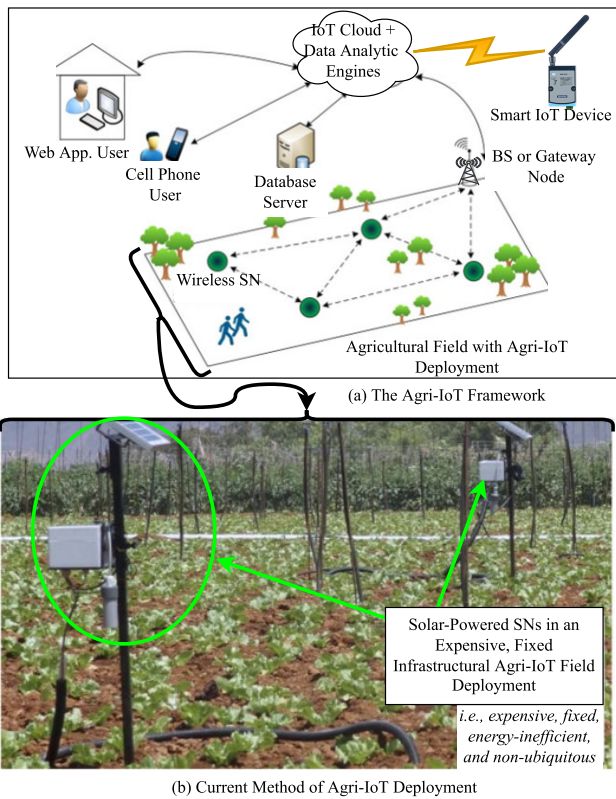

FIGURE 2. Generalized Agri-IoT framework and sample field deployment test-bed from the state-of-the-art.

Furthermore, the canon Agri-IoT test-bed solutions in [3], [5], [14], [15], and [18], as illustrated in Fig 2b, rely on fixed support systems (e.g., wired SN, servers, and gateway backbones), high-complexity event routing architectures, and expensive WiFi/WiFi-Cellular-based communication technologies for SNs' communication. These make them expensive, location-restricted, energy-inefficient, and too complicated for non-experts and poor smallholder farmers, who constitute over two-thirds of the economically active global population [2], [6]. Coincidentally, these solutions were also tested under indoor environmental conditions [13], [16], [29], making their results unrealistic for accurately assessing their respective performance indicators [3], [17]. Although some of these test-beds function in outdoor conditions [3], [5], [14], [15], setting up such test-beds and managing the experimental SNs via centralized/flooding-based routing architectures with wired backbones can be time-consuming, location-constrained, effort-intensive, complicated, and capital-intensive for most farmers in Africa, especially when the network scales in both size and SN-count (i.e., in large-scale networks).

Although the cluster-based architecture [27], [30], [31], [32], [33], [34] and the freely available low-power, wireless communication technologies, such as Bluetooth Low-Energy (BLE) and LoRa, have emerged with transformative capacities to address the stipulated technical challenges of WSN-based Agri-IoT [4], [8], [35], they have received

inadequate contextual research considerations in terms of real-world test-bed implementations and hardware evaluations because of the following technical challenges:

- Lack of robust, low-power, flexible, location-independent, low-cost, and stable real-world test-bed architectural framework for CA-IoT that uses the freely available, low-power wireless communication standards, such as BLE and LoRaWAN so that the resulting network can be easily deployed and wirelessly managed without expensive fixed supporting infrastructure.
- There is an urgent demand for a more comprehensive reference document that provides an in-depth, real-world account of the total experiences spanning from custom-built SNs' design to real-world deployment, and the assessment of the resulting network's performance under indoor and outdoor environmental conditions. Thus, there is a need to investigate how the aforementioned benefits of cluster-based architecture evolve in custom-built CA-IoT networks.
- There is a need to study the impact of weather conditions (e.g., humidity, temperature, dust concentration levels, rainstorms, and crop obstructions) on radio communication (e.g., the effective range and link quality of BLE or LoRa) in a typical Sub-Saharan African setting.

Consequently, an in-depth account of real-world experiences of context-relevant evaluation of CA-IoT based on freely available wireless communication technologies (e.g., LoRa and BLE) via a realistic CA-IoT architecture, such as in [4], [8], and [13], which can be validated under both indoor and outdoor environmental conditions is imperative. Therefore, this study proposes a WSN-specific CA-IoT test-bed that consists of the following:

- Custom-built, low-power, robust, and task-scalable SNs and CA-IoT network based on BLE 4.2 wireless communication technology so that the resulting network is location-independent, user-friendly, easily deployed, and wirelessly managed without any cost-intensive fixed support system.
- A comprehensive account of our CA-IoT network framework covering the successes and failures during SN design, SN deployment, network operations, and cloud data storage that can serve as a reference document for the Agri-IoT community.
- Real-world performance assessment of the evolution of the stipulated theoretical benefits of the cluster-based architecture.
- Study the impacts of weather conditions, physical obstructions, and SNs power variations on BLE radio connectivity and packet losses.

The rest of this paper is organized as follows: Sections II and III present a systematic literature review of this study and a theoretical overview of our approach while Section IV focuses on test-bed design. Sections V, VI, and VII present our validation experiments, results, and conclusions, respectively, with future work.

II. LITERATURE REVIEW ON REAL-WORLD WSN-BASED AGRI-IOT TESTBED SOLUTIONS

It is well documented that WSN-based Agri-IoT is the most reliable remedy for mitigating the negative impacts climate change has had on agricultural production, for which many architectural designs and testbed prototypes have been proposed [13], [29]. Since the autonomous, resource-constrained SNs in Agri-IoT are expected to operate without post-deployment maintenance checks, the issues of fault management (FM), power optimization, and self-organization during SN design and network deployment remain critical design factors that cannot be ignored in existing testbed solutions [13], [36]. However, the results from most research projects on Agri-IoT relied on simulation experiments [3], [16], [17], and the testbed solutions are based on indoor deployment conditions and the classic WSN-based IoT design principles [3], [5], [14], [15], [16], [17], [37], [38], [39] without critical considerations of the aforementioned design factors. Consequently, the gap between the philosophy of this technology and the comprehension of its real-world behavior for a more accurate performance assessment has not been resolved. To understand how the benchmarking realization testbeds of Agri-IoT in [3], [5], [14], [16], [17], and [15] fared in real-world operational conditions, results from their respective performances are systematically evaluated and summarized in Table 2. Additionally, the following challenges were observed from the systematic assessment of the stipulated solutions. It was discovered that the current benchmarking testbed solutions in [3], [5], [14], [15], [16], [17], [40], [41], [42], and [43] are capital-intensive because they are reliant on fixed/location-restricted backbone infrastructures (see Figure 2), too complicated to deploy and manage by even expert users, based on unrealistic indoor conditions which do not commensurate real-world environmental conditions, and based on the high-power-demanding centralized or flooding architectures which further complicate network manageability when up-scaled. It was also discovered in [3], [5], [14], [15], [37], [38], and [39] that the embedded communication technology, event routing architecture, and the SNs' power management are the core factors that made them capital-intensive and complicated to both experts and low-income farmers. Additionally, self-healing, reconfigurability, and adaptability mechanisms to faults were not deployed [8], [16], [17]; hence, faulty and turbulent conditions could not be tolerated. Furthermore, since the battery-powered SNs rely on expensive Wi-Fi and cellular communication technologies that are not freely accessible at all locations, the SNs exhausted their battery supply a few days after deployment. Similarly, those that relied on ZigBee/IEEE 802.15.4 communication technologies with power-intensive 6LoWPAN or IPv6 protocols restricted the resulting network to drive on the problematic centralized or flooding architectures without any efficient FM techniques. As a result, these solutions used costly fixed IP infrastructural supports and the centralized routing architecture, making

them practically impossible to manage as the networks scaled. This is why the SNs unstably exhausted their battery power and abruptly abridged network lifespans [3], [5], [14], [15], [16], [17].

Therefore, the freely available low-power wireless technologies (e.g., LoRa, BLE, 5G, Z-wave, NB-IoT, and SigFox) that are founded on a suitable routing topology are the best candidates for making this ubiquitous application [4], [17] cheap [17], [18] and simple for all users. Thus, the cluster-based topology is more pivotal to addressing the above challenges of Agri-IoT [3], [8] than the traditional cellular and Wi-Fi technologies that are inaccessible in many farms, depending on their locations [3], [18]. However, besides distance-power constraints, architectural support, and network manageability challenges, these freely accessible wireless communication technologies have specific limitations, which include:

- 1) ZigBee technology achieves the desired power savings only when deployed in star or centralized topology [16], and it operates at its low-power distance range (10–100 m) in line-of-sight mode depending on the environmental characteristics.
- 2) LoRa is limited to low-density and fixed network sizes (non-scalable), a low data rate, and a low message capacity [16]. It is a long range and a low-power technology that can be merged with BLE to achieve long ranged cluster-based topology.
- 3) SigFox supports a very low data rate and requires registration. SigFox possesses complex implementation because it requires specific modules to function and gateways.
- 4) Wi-Fi, GPRS, cellular technologies, and NB-IoT are high power consumption standards and location-/architecture-restricted.
- 5) BLE has a short communication range but supports clustering architecture, which is the most optimal architecture for ensuring the best operational efficiency of WSN-based Agri-IoT deployments, since this architecture allows cluster isolation and management.

Therefore, a research opportunity exists for a flexible, ubiquitous, realistic, energy-efficient, self-healing, simple, low-cost, cluster-based, and wireless outdoor-based testbed that consists of infrastructure-less, task-scalable, and wirelessly configurable experimental SNs and a BS. It should also be deployed, re-deployed, monitored, controlled, and managed by non-experts to operate stably throughout the entire crop-growing season. This study addresses this gap.

III. OVERVIEW OF WSN-BASED AGRI-IOT ARCHITECTURES AND TEST-BEDS

A WSN-based Agri-IoT test-bed is both a knowledge- and information-intensive sampling-based feedback control system that is mostly used for farm monitoring, data processing, and making actionable decisions, which helps manage precision farms or greenhouses. Additionally, Agri-IoT technology can automate all farm management processes,

TABLE 1. Comparative analysis of WSN-based Agri-IoT testbed solutions.

Author/Deployment Type	Testbed Objective	Comm. Tech& Architecture	Weaknesses
[3] (Outdoor)	Disease control	IEEE 802.15.4 /centralized, flooding	Relied on a fixed support system, expensive, power-inefficient, location-restricted
[14] (Outdoor)	Precision farming, to gather real-world experiences	ZigBee, Mica2 clones hardware and TinyOS software /centralized, flooding	Relied on a fixed support system, expensive, power-inefficient, location-restricted, no single measurement was achieved due to high network complexity
[5] (Indoor)	Data outlier detection and decision support system for precision irrigation testbeds	ZigBee/flooding-based	Results based on 3 SNs under unrealistic indoor conditions
[15] (Indoor)	Latency improvement	Fog computing, 6LoWPAN, 6LBR, and WiFi-based /centralized, flooding	Capital-intensive, energy-inefficient, high complexity, location-restricted
[17], [38], [39] (Indoor and Outdoor)	Gather real-world deployment experiences	ZigBee /centralized, flooding	Result focused on mere observation, not real-world deployment scenarios.

such as precision irrigation, chemical application, and remote disease management [4], in order to ensure remote monitoring, planning, and control of farm processes via battery-powered SNs that are equipped with sensing (e.g., microclimatic sensors such as DHT22 and STEMMA soil moisture sensors), processing (e.g., RPi 3 B+, Arduino Uno), and communication capacities (e.g., LoRa, ZigBee, BLE, Wi-Fi, NB-IoT, SigFox [23], [44], [45]). Because Agri-IoT networks are compelled to drive on batteries and distance-constrained communication technologies, the embedded routing architecture in the supervisory network management protocol plays a critical role in ensuring efficient power savings, network management, fault management, network adaptability/scalability, and event-monitoring accuracy [1], [3], [4]. The key expectations of an Agri-IoT routing architecture and its implementation mechanisms via CA-IoT network architecture are presented in Figure 3. Regardless of the routing architecture, the layers of the event flow framework and the principal components of Agri-IoT generally consist of the “Things” unit (i.e., perception layer), Base Station(BS)/Gateway (i.e., network layer), and the Cloud (i.e., application and end-user layer) [9], [46], [47], as illustrated in Figure 4.

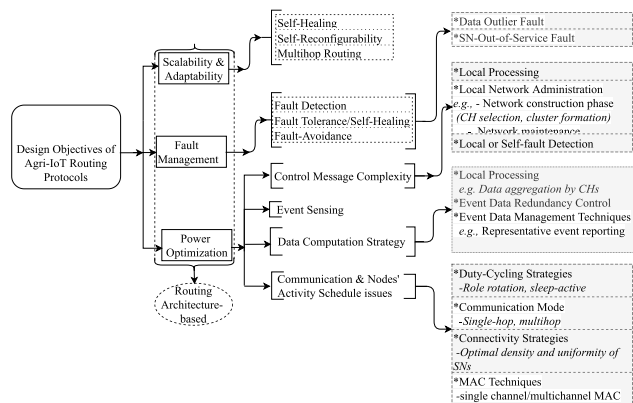

FIGURE 3. Expected design objectives of WSN-based Agri-IoT routing protocols with sample implementational strategies.

There are two routing architectures: centralized and distributed (e.g., flooding/graph-based and tree- or cluster-based) [4], [9]. The centralized architecture routes data to

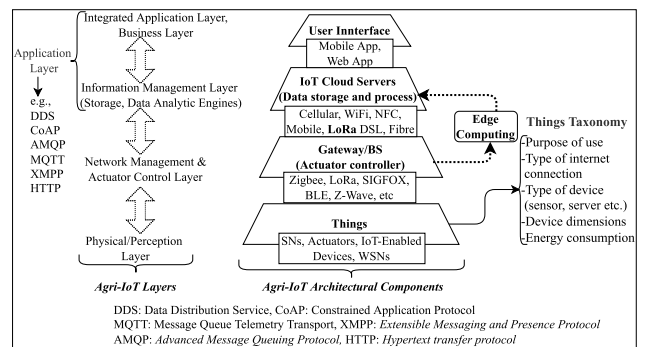

FIGURE 4. Architectural layers of WSN-based Agri-IoT, Key components in each layer, and sub-classification of the things layer [9].

a BS in one-hop while the decentralized architectures flood data to the BS via multihop communications [1], [13], [30]. A centralized architecture is energy-inefficient, fault-vulnerable, and too complex to implement in large-scale turbulent networks [4]. Consequently, most related test-bed solutions based on this architecture can not operate under outdoor conditions [16], [17]. In this study, our custom-built SNs were adapted to a customized network supervisory protocol for clustering architecture, as shown in Figure 5.

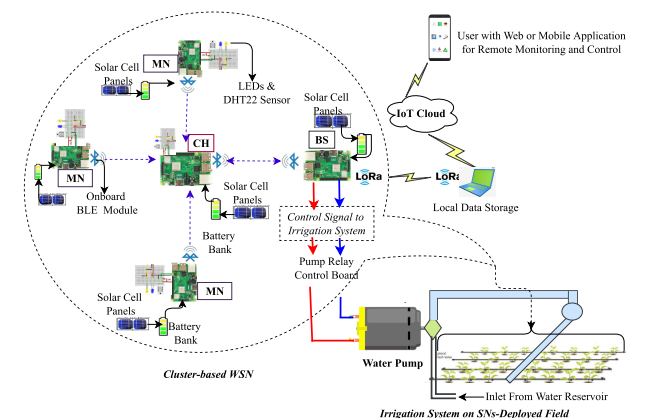

FIGURE 5. Custom-built WSN-based Agri-IoT architecture for precision irrigation application.

In a typical CA-IoT architecture, such as that proposed in Figure 5, SNs are grouped into either static or dynamic

clusters, each with an optimally selected cluster head (CH) to minimize intra-cluster communication distances among member nodes (MNs). An MN samples the soil moisture/livestock data and transmits it to its CH. A CH aggregates the received readings from its MNs, executes error and data redundancy control checks, and communicates directly or via a relay CH (RCH) to a BS/gateway to enhance the event data quality and network lifespan. This checks for data inconsistency errors and saves the power wasted in transmitting a large amount of redundant data to the BS. The BS can process the received data and make local actionable decisions to actuate the irrigation system, send the raw or preprocessed data to the IoT cloud for further processing, and return the actionable decisions to the BS for execution. Generally, the sensors installed on the Agri-IoT's field participants (*e.g.*, MNs and CHs in Figure 5) sample microclimatic data of the field, location data, or crop data to Arduino- or RPi-based SNs for local processing and decision making. The resulting actuation signal is sent to the irrigation pump for precision irrigation or chemical application. Copies of data can be stored in the IoT cloud for remote monitoring/control, or further analysis to uncover the field's climate pattern that can be used to automate the entire irrigation system. Because communication is the principal power consumer in WSN-based Agri-IoT and its key determinants (*i.e.*, distance and packet size) can be optimally moderated by the cluster-based architecture [13], [48], [49], [50], [51], it can be concluded that this architecture is the best approach for power optimization in these networks. Although cluster-based architecture is the best candidate for WSN-based Agri-IoT applications [9], this assertion has not been validated because of inadequate research considerations in terms of hardware evaluation to exploit its numerous unfulfilled potentials.

In Agri-IoT test-beds, the embedded communication technology, event routing architecture, and SNs' power supply are the core drivers of operational stability, cost, and deployment-management complexities to users. Therefore, because the battery-powered SNs are mostly deployed in fields where expensive WiFi and cellular communication technologies cannot be freely accessed, the freely available low-power wireless technologies, such as LoRa, BLE, ZigBee, or IEEE 802.15.4 standard, and SigFox, which are founded on a suitable routing topology and the theoretical frameworks in [4], [8], and [13] are the best candidates for making this application ubiquitous [4], [17], inexpensive [17], [18], and robust and simple for all users. However, besides distance-power constraints, architectural support, and network manageability challenges, these freely accessible wireless communication technologies have specific limitations, which include the following.

1) ZigBee and Z-Wave can achieve the desired power-savings only when deployed in a low-density, mesh-like, or centralized topology [16]. They are meant for home automation and operate in a low-power distance range (10–100 meters) in line-of-sight mode

depending on the environmental characteristics. They have unbounded latency, unreliable MAC (CSMA/CA), low data rates, and high susceptibility to interference and multipath fading. ZigBee IP adopts the 6LoWPAN adaptation layer, IPv6 network layer, and a highly resource-demanding RPL routing protocol [9].

- 2) LoRa is limited to low density and fixed network sizes (non-scalable), low data rate, and low message capacity [16]. It may require registration and expensive antennae, depending on the operation location.
- 3) SigFox supports a very low data rate and may require registration. LoRa and SigFox have complex implementations because they both require specific modules/gateways to function.
- 4) WiFi, GPRS, and cellular technologies (*e.g.*, LTE-M and NB-IoT) are high power consumption standards, and location- or architecture-restricted (require cellular access).
- 5) BLE is a short-range communication protocol that supports clustering architecture with the highest energy-saving capacity.
- 6) Near field communication (NFC) and Radio Frequency Identification (RFID) protocols are used for short-range communication (up to 4 cm), such as check-in systems and inventory systems.

Because of the lack of critical consideration of the above architecture-related issues, *vis-À-vis* environmental constraints, the benchmarking test-beds in [3], [5], [14], and [15] suffered severe network management challenges and abrupt SNs failure owing to fast battery depletion rates. These issues can be easily addressed using the proposed CA-IoT network architecture shown in Figure 5 via an energy-efficient network management algorithm, fault-tolerant techniques, low-power communication technology, participants' duty cycling, and solar-based energy harvesting techniques. These summarize the realistic expectations of our customized CA-IoT network participants (*i.e.*, MNs, CHs, and BS) in Figure 1, which include high energy efficiency, installation and operational simplicity, flexibility, affordability, fault tolerance, operational stability with incorporated avenues for remote monitoring/control, and operational modifications of the WSN-sublayer during the entire crop growing season [3], [4], [8].

Additionally, WSN-Based Agri-IoT must be founded on the theoretical propositions in [4] and [8] and the routing principles in [4], [29], [52], and [8] to attain the desired performance. This requires additional performance optimization parameters. For instance, the desired cluster quality at minimized packet loss rates, the received signal strength indicator (RSSI) levels of the BLE transceiver modules at distance d and the associated surface power levels (P_d) can be estimated using the following expressions:

$$P_d = \frac{P_{d_0}}{d^\alpha}, \quad (1)$$

$$RSSI_d = -20 \log(d) + RSSI_{d_0}, \quad (2)$$

where $\alpha = (2, \dots, 6)$ is an atmospheric parameter. Using the RPi 3 B +’s built-in isotropic BLE transceiver antenna with gain G that radiates the same intensity of radio waves in all directions, the surface power density at radius or distance d from the transmitter T_x can also be expressed as:

$$P_{density} = \frac{P_{Tx}G}{4\pi d^2} \quad (3)$$

Because the SNs in CA-IoT are compelled to drive on battery power with its specifications expressed in Amp-hours (AH) terms, the average power consumption of the MNs and CHs, I_{MN} and I_{CH} , in different operational modes can be expressed as:

$$\bar{I}_{MN} = \bar{I}_{standby} + \bar{I}_{Rx} + \bar{I}_{sp} + \bar{I}_{Tx}, \quad (4)$$

$$\bar{I}_{CH} = \bar{I}_{idle} + \bar{I}_{Rx} + \bar{I}_{DA} + I_{Tx}, \quad (5)$$

where $\bar{I}_{standby}$, \bar{I}_{Rx} , \bar{I}_{da} , \bar{I}_{sp} , and \bar{I}_{Tx} represent the power depleted during standby when SNs are in the low power listening mode, data reception, data aggregation, sampling/data processing by MNs, and data transmission respectively. These expressions help to estimate participants’ automation spans to maximize the network’s lifespan and performance. Finally, the availability of *a priori* SNs location information in an agricultural environment can help optimize network resource utilization, incorporate suitable fault management techniques, and establish throughput and latency thresholds via cluster sizing to attain the desired network lifespan. These merits have not been achieved in randomly deployed, centralized, or flooding-based routing architectures in benchmarking test-bed solutions [3], [4], [14], [16], [17], [18].

Effective implementation of these expressions during the SN design, software development, and network deployment phases can yield optimal cluster quality, high energy efficiency, and improved event data quality [4], [8], [13], [29]. Therefore, the most energy-efficient low-power wireless communication technology that supports a clustering architecture is the most suitable candidate for custom-built SNs and WSN-based Agri-IoT applications.

To achieve the intended global significance and paradigm transformation in the agricultural sector, a real-world Agri-IoT solution is required to satisfy its intended users’ expectations as well as the desired performance efficiency requirements in Figure 1. Thus, because most farmers, especially those in African, are low-income earners with low technological expertise, users expect the resulting network to be affordable, simple to deploy and operate by non-experts, location-unrestricted, supportive of large scale farm management, and based on freely available technologies that do not require licensing. Similarly, performance expectations refer to the robustness of the technology in terms of power optimization, support for high SN deployment densities, fault tolerance, and self-adaptability to scalable and turbulent conditions without interfering with the core business function of the technology, as previously established [4], [8], [13]. It is evident from related test-bed solutions and the above expectations that the centralized-based network architecture,

which has been frequently used in most benchmarking Agri-IoT test-beds, does not fully support the desired agenda of this technology, whereas the cluster-based architecture does. However, the desired contextual hardware evaluation of CA-IoT networks has not received the desired research consideration.

A. DESIGN CONSIDERATIONS OF CA-IOT NETWORK PARTICIPANTS

As illustrated in Figure 5, the three main participants of our CA-IoT networks include MNs, CHs, and BS, which are similar in terms of hardware components/units and differ in terms of assigned tasks and resource capacities (*i.e.*, power, memory, and processing), as well as underlying supervisory software. For instance, a CH and BS require more resources for data processing than MNs in a cluster. The core units of a CA-IoT participant are presented in Figure 6 with possible hardware examples, which can be elaborated as follows:

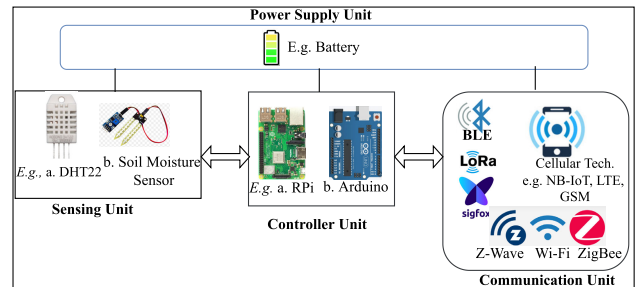

FIGURE 6. The principal components of SNs with sample design options in Agri-IoT.

- 1) Sensing Unit: This unit interfaces with the physical environment to record the physical phenomenon being monitored. The sensors incorporated in CHs and MNs (*e.g.*, STEMMA soil moisture sensors) monitor the physical phenomenon of interest, while those in BS (*e.g.*, DHT22 and DHT11 sensors) monitor the ambient operating conditions so that they do not operate beyond their environmental thresholds. Generally, Agri-IoT sensors are application-specific and can be contact-based or non-contact-based. In this precision irrigation use-case, STEMMA soil moisture sensors and DHT22 temperature and humidity sensors in Figure 6 were used for soil micro-parametric sensing and ambient environmental condition monitoring of the participants, respectively.
- 2) Controller Unit: This unit hosts the microprocessor, storage, and connection pins for all other units and auxiliary peripherals. Common controllers for building Agri-IoT participants can be Arduino-based or RPi-based. There are other off-the-shelf application-specific controllers [53], such as the ProPlant Seed Rate Controller, John Deere GreenStar Rate Controller, Viper Pro multi-function field computer, Radion 8140, and Trimble Field-IQ. An RPi 3 B + with built-in BLE/Wi-Fi Modules was used in this study.

- 3) **Communication Unit:** This unit is the principal determinant of a participant's energy efficiency, communication distance, operational stability, affordability, cost, routing architecture, resource requirements, and other requirements of the associated routing protocol [4], [9], [13], [54], [55]. Figure 6 illustrates the available communication technologies. However, the best candidates for CA-IoT applications must be energy-efficient, affordable, freely available, simple, cluster-supportive, and reliable communication standards. Because selecting a suitable communication technology involves multi-parametric components vis-a-vis their demerits, a decision matrix must be formulated based on the target application and routing architectural goals. For instance, even though BLE is distance-constrained, it has cheap antennas and is widely integrated into most IoT devices whereas LoRa and SigFox possess complex implementations because they both require specific modules to function, require registration to operate, demand interconnections via gateways, and do not support cluster-based architectures with densely deployed WSN sublayers [9], [15]. Unlike classic Bluetooth, BLE 4.2 and beyond can support an unlimited number of slaves (*i.e.*, densely deployed WSN sublayers of Agri-IoT applications). Contrary to BLE, the ZigBee standard is restricted to a centralized architecture and relies on high-resource-demanding protocols (*e.g.*, RPL- and AODV-based family of protocols) to operate. Although BLE is distance-constrained compared to LoRa, ZigBee, SigFox, WiFi, and cellular-based technologies, the technology selection analysis in later sections revealed that it is the most energy-efficient [16], [56], [57], cheap, and suitable approach for cluster-based architectures [4], [8], [13], [49]. Consequently, the BLE and LoRa communication technologies were selected for the WSN sublayer and BS-cloud communications, respectively.
- 4) **Power Unit:** Because CA-IoT participants are mostly battery-powered, appropriate battery sizing and probable energy-harvesting techniques must be determined during the participants' design phase for the intended network lifespan. There are modern trends in battery power banks with integrated solar-based energy-harvesting systems and power ratings above 30000mAh.

During the selection of the hardware components in this study, extreme caution was taken to avoid unit incompatibility, high operational complexities, unsuitable operational thresholds, and high energy consumption requirements. This implies that high component survivability and operational stability under different environmental conditions and context-relevance are equally vital determinants. In addition, a supervisory routing protocol must be incorporated to oversee the network/architectural construction, event sampling, data transmission/management, fault management, network maintenance/reconstruction, and actuator control to

deploy network participants in the field. The supervisory protocol of this study was based on the RCEFT protocol in [13].

In addition to hardware and software considerations, other auxiliary factors, such as external weather and internal operating conditions, need to be considered. For example, a wide variation in temperature requires hardware capable of withstanding such harsh environments. Fluctuations in humidity can also affect the long-term success of a system. Most Agri-IoT environments must contend with the impacts of dust concentration and physical obstructions on operational efficiency. Acoustic materials can affect connections over which power or communications travel. The mounting of SNs in the field must also be performed well to ensure connectivity.

B. STATE OF THE ART ON REAL-WORLD, CANON WSN-BASED AGRIO-IOT TESTBED SOLUTIONS

It is well documented that WSN-based Agri-IoT is the most reliable remedy for mitigating the negative impacts climate change has had on agricultural production, for which many architectural designs and testbed prototypes have been proposed [13], [29]. In addition, since the autonomous, resource-constrained SNs in Agri-IoT are expected to operate without post-deployment maintenance checks, the issues of FM, power optimization, and self-organization during SN design and network deployment cannot be ignored in existing testbed solutions [407, 463]. Essentially, the results from most research projects on Agri-IoT relied on simulation experiments [3], [16], [17], which have retained the gap between the philosophy of this technology and the comprehension of its real-world behavior for a more accurate performance assessment. This subsection presents a systematic performance assessment of the few real-world WSN-based Agri-IoT testbed solutions currently based on the classic WSN-based IoT principles. To understand how the benchmarking realization testbeds of Agri-IoT in [3], [5], [14], [16], [17], and [15] fared in real-world operational conditions, the results from their respective performances are systematically evaluated and summarized in Table 2. It was discovered that the current benchmarking testbed solutions in [3], [5], [14], [16], [17], and [15] are capital-intensive because they are reliant on fixed/location-restricted backbone infrastructures (see the bottom of Figure 2), too complicated to deploy and manage by even expert users, based on unrealistic indoor conditions which do not commensurate real-world environmental conditions, and based on the high-power-demanding centralized or flooding architectures which further complicate network manageability when up-scaled. A concise and systematic survey of these benchmarking real-world Agri-IoT networks and their flaws in the state of the art is summarized in Table 2.

Additionally, it can be established from the comparative assessment of the benchmarking Agri-IoT testbeds in Table 2 ([3], [5], [14], [15]) that the embedded communication technology, event routing architecture, and SNs'

TABLE 2. Comparative analysis of WSN-based Agri-IoT testbed solutions.

Author/Deployment Type	Testbed Objective	Comm. Tech & Architecture	Weaknesses
[3] (Outdoor)	Disease control	IEEE 802.15.4/centralized, flooding	Relied on a fixed support system, expensive, power-inefficient, location-restricted
[14] (Outdoor)	Precision farming, to gather real-world experiences	ZigBee, Mica2 clones hardware and TinyOS software/centralized, flooding	Relied on a fixed support system, expensive, power-inefficient, location-restricted, no single measurement was achieved due to high network complexity
[5] (Indoor)	Data outlier detection and decision support system for precision irrigation testbeds	ZigBee/flooding-based	Results based on 3 SNs under unrealistic indoor conditions
[15] (Indoor)	Latency improvement	Fog computing, 6LoWPAN, 6LBR, and WiFi-based/centralized, flooding	Capital-intensive, energy-inefficient, high complexity, location-restricted
[17], [58], [37] (Indoor and Outdoor)	Gather real-world deployment experiences	ZigBee/centralized, flooding	Result focused on mere observation, not real-world deployment scenarios.

power management are the core factors that made them capital-intensive and complicated to both experts and low-income farmers. Additionally, self-healing, reconfigurability, and adaptation mechanisms to faults were not deployed [8], [16], [17]; hence, faulty and turbulent conditions could not be tolerated. Furthermore, since the battery-powered SNs rely on expensive Wi-Fi and cellular communication technologies that are not freely accessible at all locations, the SNs exhausted their battery supply a few days after deployment. Similarly, those that relied on ZigBee/IEEE 802.15.4 communication technologies with power-intensive 6LoWPAN or IPv6 protocols restricted the resulting network to drive on the problematic centralized or flooding architectures without any efficient FM techniques. As a result, these solutions used costly fixed IP infrastructural supports and the centralized routing architecture, making them practically impossible to manage as the networks scaled. This is why the SNs unstably exhausted their battery power and abruptly abridged network lifespans [3], [5], [14], [15], [16], [17].

Therefore, the freely available low-power wireless technologies (e.g., LoRa, BLE, 5G, Z-wave, NB-IoT, and SigFox) that are founded on a suitable routing topology are the best candidates for making this ubiquitous application [4], [17] cheap [17], [18] and simple for all users. Thus, the cluster-based topology is more pivotal to addressing the above challenges of Agri-IoT [3], [8] than the traditional cellular and WiFi technologies that are inaccessible in many farms, depending on their locations [3], [18]. However, besides distance-power constraints, architectural support, and network manageability challenges, these freely accessible wireless communication technologies have specific limitations. Therefore, a research opportunity exists for a CA-IoT network that is flexible, ubiquitous, realistic, energy-efficient, self-healing, simple, low-cost, cluster-based, and wireless outdoor-based testbed that consists of an infrastructure-less, task-scalable, and wirelessly configurable experimental SNs and a BS. It should also be deployed, re-deployed, monitored, controlled, and managed by non-experts to operate stably throughout the entire crop-growing season.

IV. HARDWARE VALIDATION OF PROPOSED CA-IOT TEST-BED DESIGN AND IMPLEMENTATIONS

This section presents a detailed account of the physical design, deployment, and validation/testing of the proposed

CA-IoT network for precision irrigation. As shown in Figure 5, the purpose, behavior, and requirements of the proposed CA-IoT system (such as data collection, data analysis, system management, data privacy/security, and user interface requirements) are evaluated in this phase. This premier attempt is intended to help the Agri-IoT community exploit the merits of the clustering topology to attain the desired network power-savings/automation span, network management, operational efficiency, and event data quality. In addition to design and operational simplicity and flexibility and network participants' task and network scalability, our CA-IoT also operates on simple software and commands that can be executed on an RPI or PC with a focus on providing rich set measurements for educational and outdoor purposes.

The CA-IoT network participants (*i.e.*, MNs, CH, and BS), as illustrated in Figure 7, are custom-built from RPI 3 B +-based controllers with other crossed platform hardware and software components based on their specific tasks and demands. Consequently, the network participants are task-scalable and easily role-rotated. According to the hardware schematic shown in Figure 7, the MNs sample soil temperature and moisture data were transmitted to the CH. The CH then removes data outliers, aggregates the received measurements in addition to its local measurements, and transmits the aggregated data to the BS for local actionable decisions while keeping a copy in the Google sheet and the project's GitHub. An actuation signal was sent to the irrigation controls system to activate the water pump. RPI 3 B + was selected because of its operational stability under various environmental and operating conditions. The essential factors that guided the hardware selection in Figure 7, software design, and the entire design of this CA-IoT include the following:

- **Architectural support:** We selected components and technologies (*e.g.*, BLE) that support the cluster-based architecture in to take advantage of its embedded merits.
- **Component Affordability:** Cost-effective components and technologies were used to make the resulting system affordable to users.
- **Simplicity and Usability:** This CA-IoT network is infrastructure-less, entirely battery-driven, simple to deploy and manage, labor-saving, and flexible/wireless, making its applications ubiquitous, topologically malleable, and easier to integrate into any existing

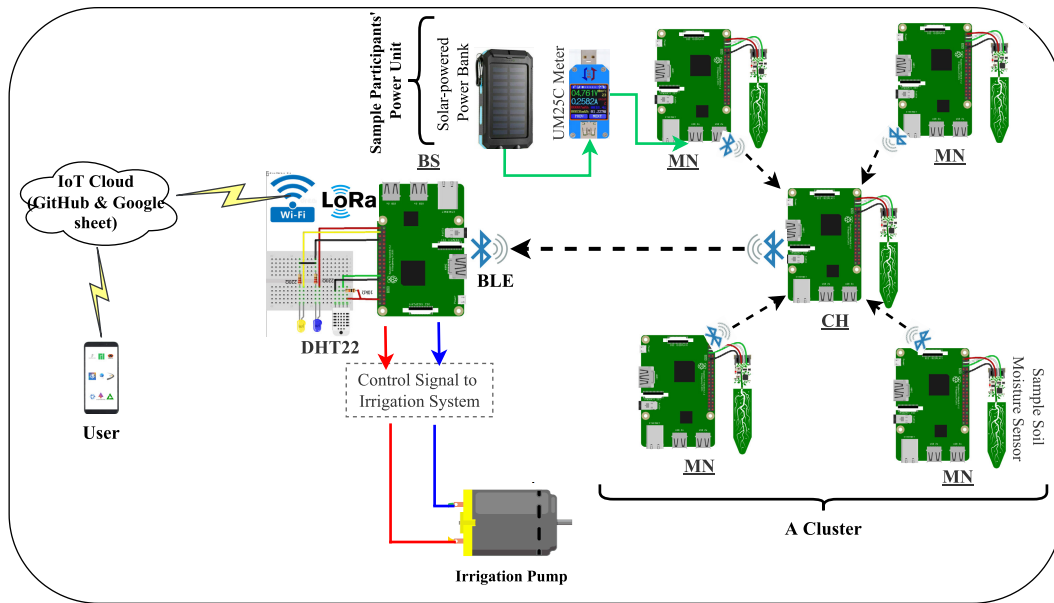

FIGURE 7. 1-Cluster schematic diagram of proposed CA-IoT implemented on test-bed.

real-world test-bed without any fixed supporting infrastructure in the field.

- **Energy-saving Capacity:** Low-power components and their support for energy-saving techniques, such as duty-cycled sampling schedules and control of redundant data transmission, were enabled so that our network framework could be easily integrated into any precision farming and greenhouses to perform efficiently throughout the entire crop season.
- **Ability to withstand and operate stably in harsh environments:** During the pre-testing phase, the hardware components were subjected to similar climatic extremes (e.g., temperatures between 40°C and 51°C), similar to the actual conditions in Senegal. For instance, the RPi 3 B + was selected over Arduino-based and other RPi-based controllers because the former operated stably under these conditions, whereas the rest failed even under indoor conditions.

By implication, there is a direct relationship between IoT network technology and its supporting routing architecture, use cases (i.e., what to connect, where to connect, how much data to transport at what interval, and over what distance), and data pattern (packet size and communication intervals).

A. HARDWARE COMPONENTS

A detailed overview of all hardware components, as well as their step-by-step assembly and integration processes, is presented in our collaborative paper [55]. In this subsection, the core hardware components used to design our CA-IoT participants (i.e., MNs, CHs, and BS), their functions, and why they were selected are presented in Table 3.

RPi 3B+ is a low-power single board mini personal computer frequently used for real-time Image/Video Processing,

IoT-based applications, and robotic applications. Because this experimental network is being built for unrestricted locations and hostile environmental applications in Africa, RPi 3 B + was selected based on its operational stability under diverse and adverse environmental conditions. It also comes with enhanced specification such as built-in radio module for BLE 4.2 and dual-band WLANs that supports 2.4GHz and 5GHz Wi-Fi, good speed of 1.4GHz, 1GB SDRAM, good throughput of 300Mbps, and a Power over Ethernet (PoE) port via a separate PoE HAT, which allows the Ethernet cable to power the board. In this experiment, the PoE switch was used to minimize cabling complexity while the onboard VNC server and Wi-Fi helped to remotely access and program the RPi from both Windows and Linux Desktops via the VNC Viewer and SSH, respectively. In addition to these reasons for the selection on RPi 3 B + in Table 3, the pre-testing phase subjected RPi 3 B +, RPi 4 and Arduino Uno controllers to similar climatic extremes such as in Senegal (for example, temperatures between 40°C and 51°C under indoor conditions) and the RPi 3 B +-based participants outperformed the rest.

Because the selected communication technology plays a significant role in this network, an in-depth set of technology selection metrics was derived and ranked based on the proposed CA-IoT network's design and performance expectations. Using the derived technology selection metrics and the technology selection matrix in [59], detailed parametric analysis and ranking and suitability analysis and rankings of communication protocols were estimated, as presented in Figure 4. Based on the stipulated network's operational and architectural requirements, and the assessment results in Figure 4, the onboard BLE 4.2 communication technology was judged as the most suitable for both intra-cluster and

TABLE 3. CA-IoT participants hardware components list.

Hardware Component	Function	Why selected
RPi 3B+ Controller	Processing, storage, hosting other hardware peripherals; serves as main controller for MNs, CHs, and BS	Has onboard Wi-Fi and BLE 4.2 radio modules and PoE port for easy remote programming, cheap, ubiquitous, and ability to withstand adverse weather conditions
LoPy microchip	Has inbuilt LoRa, SigFox, Wi-Fi, and BLE communication modules, of which LoRa or Wi-Fi is selected for communication between the BS and the IoT cloud (<i>i.e.</i> , google sheet and GitHub).	Because it has cheap and flexible communication options for different CA-IoT applications
BLE 4.2 Module	For intra-cluster and inter-cluster communication	It supports the cluster-based architecture without fixed infrastructural requirements as well as ubiquitous, simple to implement, and cheap.
DHT22 Adafruit sensor	For the management BS' cooling system	It's hardy, accurate with wider/suitable measurement range, and freely available libraries at Adafruit Library.
STEMMA soil moisture sensor (Adafruit)	For sampling soil moisture and temperature data	It's hardy, accurate with wider/suitable measurement range, and freely available libraries at Adafruit Library.
solar-powered 30000mAh (5v/3A) LICORNE battery banks	Powered MNs	Selected based on MNs power requirements.
36000mAh (5v/3A) ANYFONG battery banks	Powered CHs and BS	Selected based on CHs and BS's power requirements.

inter-cluster communications compared with ZigBee, LoRa, SigFox, Wi-Fi, and NB-IoT/Cellular technologies, because it has ultra-low energy-saving properties, better compatibility with most mobile units, support for robust cluster-based architectural design, and high throughput. Figure 4b shows how BLE suits our target application given the available criteria. Consequently, we selected BLE for all on-site communications up to the BS. Communication beyond the BS to the cloud can be achieved via LoRa or low-power WiFi that is employed during outdoor deployment.

LoRa technology emerged as the best candidate for BS–Cloud communication for outdoor deployment for the same reasons. The BS is also equipped with a LoPy microchip with LoRa technology or Wi-Fi Mini-Box for long distance communication between the BS and the remote cloud repository during outdoor deployments in Senegal and the USA. Due to the configurational challenges with the “Things” Network (TTN) here in the USA, the network currently utilized the Wi-Fi module on the LoPy/RPi 3B+ to communicate with the cloud and the users. As shown in the information flow diagram in Figure 11, the BS receives sampled field data via its BLE transceiver and sends the received sampled data to the googlesheet or GitHub via the onboard LoPy module or ow-power Wi-Fi Mini-Box for real-time remote monitoring.

Given the role-based participants' operational states depicted in Equations 4 and 5, the associated power consumed per state as depicted in [9], and the worst-case daily activity schedules scenario at the 3-hourly sampling interval plan per the daily soil sampling convention of the authors in [16] and [17], the participants' lifespan and battery selection can be justified, as illustrated in Table 5. For a 1-hour daily total scheduled activity duration in a worst-case sampling scenario, the expected daily power consumptions of a CH and a MN are $\bar{I}_{CH} = 40.37mA$, and $\bar{I}_{MN} = 40.11mA$ (refer to details in Table 5), respectively. This implies that the expected lifespan estimations of an MN and CH/BS are 748 and 743 days, respectively, which are further stabilized by the built-in solar-based energy harvesting technique of the battery banks. Theoretically, this sufficiently justifies the selection of our power supply because it can last for several crop seasons. As power mismanagement/exhaustion is the root cause of

most faults in WSN-based Agri-IoT test-beds [13], [52], the selected power supply acts as a fault-avoidance mechanism in addition to the clustering topology, BLE standard, and duty-scheduled sampling scheme.

B. SUPERVISORY SOFTWARE DEVELOPMENT AND IMPLEMENTATION

The cluster construction, duty-cycle scheduling of event sampling, data management, and data transmission/reception were embedded in our event routing protocol, which was developed using the inbuilt Python3.7 within the RPi 3 B +’s Raspbian OS. The cluster formation process, fault tolerance scheme in [13], and cluster quality assessment technique in [29] were adopted and implemented. The BLE 4.2, ATSAM10 Adafruit STEMMA soil sensor (*i.e.*, I2C Capacitive Moisture Sensor), and DHT22 libraries were installed in the BlueZ and Adafruit libraries, respectively. The detailed SN design steps and configuration procedures were captured in our test-bed paper [55]. The Bluepy module in Python was also installed to handle multiple communications with BLE devices using the code from the BlueZ project. The main software running on the BS, CHs, and MNs as well as their modus operandi outlined in Figure 8 are detailed as follows:

- The proposed CA-IoT network has three sets of distributed network management and sampling software: MN/client software, CH client/server software, and BS/gateway/server software. The operational steps and roles of each software program are shown in Figure 8. For instance, MN software allows it to locally host a seesaw-embedded Bluetooth SOCKET client in python3.7 script for managing network construction, event sensing, BLE transceiver operational state moderation, and transmission of sampled data to the BS at specific crontab timeslots. The software shown in Figure 8a was designed using Bluetooth Socket programming, seesaw module, bluez module, local time, built-in crontab -e in Python3.7, and NTP from time.google.com.
- A CH hosts both client and server codes in a single software that helps it act as a server to its MNs and

TABLE 4. Communication technology selection matrix: (a) Analysis and ranking of principal metrics and (b) suitability analysis and ranking of wireless communication protocols for cluster-based Agri-IoT applications.

RANKING SYSTEM: 0 = row more vital than column, 0.5 = row and column equally important, 1 = column more vital than row

0.5	Transmission Range	Power Consumption	Complexity	Cluster Suitability	Event Data Quality	Latency	Security	Cost	SUM	Ranking of Metrics (High to Low)
Transmission Range		0.5	0.5	0.5	0	0	0	0	1.5	1. Power Consumption, Cluster Suitability
Power Consumption	0.5		0	0.5	0	0	0	0	1	2. Transmission Range
Complexity	0.5	1		1	0	0	0	0	2.5	3. Cost
Cluster Suitability	0.5	0.5	0		0	0	0	0	1	4. Complexity
Event Data Quality	1	1	1	1		0	0	0	4	5. Event Data Quality
Latency	1	1	1	1	1		1	1	7	6. Security
Security	1	1	1	1	1	0		0	5	7. Latency
Cost	0.5	0.5	0	0.5	0.5	0	0		2	

Priority: High to Low

a. Decision Matrix for Ranking Wireless Communication Selection Metrics

Wireless Communication Technology		BLE		LoRa		ZigBee		SigFox		Wi-Fi		NB-IoT & Cellular Tech.	
Technology Selection metric (i)	% Weight	Rating	Score Weight	Rating	Score Weight	Rating	Score Weight	Rating	Score Weight	Rating	Score Weight	Rating	Score Weight
Transmission Range (0~high, 0.5~medium, 1~low)	80	0.5	40	0	0	1	80	0	0	0.5	40	0	0
Power Consumption (0~high, 0.5~medium, 1~low)	100	1	100	0.5	50	1	100	0.5	50	0	0	0	0
Complexity (0~high, 0.5~medium, 1~low)	70	1	70	0	0	0.5	35	0.5	35	0	0	0	0
Cluster Suitability (0~Low, 0.5~ medium, 1~High)	100	1	100	0	0	0.5	50	0.5	50	0	0	0.5	50
Event Data Quality (0~Low, 0.5~ medium, 1~High)	60	1	60	0.5	30	1	60	0.5	30	0	0	0.5	30
Latency (0~high, 0.5~medium, 1~low)	30	1	30	0	0	0.5	15	0	0	0	0	0	0
Security (0~not secured, 0.5~fairly secured, 1~ secured)	50	1	50	0.5	25	1	50	0	0	0.5	25	0	0
Cost (0~high, 0.5~medium, 1~low)	40	1	40	1	40	1	40	1	40	0	0	0.5	20
		Total:	490		145		430		105		65		100
		Ranking:	1 st		3 rd		2 nd		4 th		6 th		5 th
		Choice:	Yes		No		No		No		No		No

b. Value Analysis Matrix of Core Communication Technologies and their Suitability Ranking for Agri-IoT Applications

distant-CHs and as a client to the BS or RCHs. Thus, this software consists of a Bluetooth SOCKET server and client in python3.7 scripts that control cluster construction/reconstruction and packet reception from MNs, data aggregation with MMP&AC data outlier detection and correction techniques inherited from [13], packet transmission to BS, and management of BLE transceiver states. The CH locally stores raw data from its MN and sends the aggregated data with its MN-count to the BS. This software adapts to scalable network conditions caused by SN-out-of-service faults and SN-count or network size variations. The CH software utilized modules such as Bocket, Bluetooth, sys, threading, time, csv, Queue, struct, ntplib, gspread

SCL and SDA from board, busio, and Seesaw from adafruit_seesaw.seesaw.

- Similarly, the BS software also contains the Bluetooth SOCKET server script in python3.7 for managing network construction, reception and storage of event data, BLE transceiver operational state moderation, and transmission of received sampled data to the cloud at specific timeslots. Thus, the software running on the BS uses Bluepy, Bluez, and API to communicate with CHs via the BLE module at scheduled times to receive sampled data and store it locally in a .csv file and globally in Google sheet for remote monitoring. The BS further processes the received data, and if the result exceeds a preset threshold, an actuation signal is sent

TABLE 5. Justification of participants’ power supply selection using lifespan.

Power Consumption of CH	Power Consumption of MN	Worst-case Operational Assumptions
$\bar{I}_{CH_standby} = 40mA$	$\bar{I}_{MN_standby} = 39.47mA$	SN active, T_x off mode
$\bar{I}_{CH_Rx} = \frac{42.21 \times 15 \times 10^{-3}}{20} = 0.32mA$	$\bar{I}_{MN_Rx} = \frac{40.11 \times 15 \times 10^{-3}}{10} = 0.6mA$	average consumption R_x -mode for a 15ms pulse every 20s and 10s
$\bar{I}_{CH_Tx} = \frac{43.1 \times 200 \times 10^{-3}}{1800} = 0.0048mA$	$\bar{I}_{MN_Tx} = \frac{40.62 \times 50 \times 10^{-3}}{1800} = 0.00112mA$	average consumption T_x -mode for 200ms/50ms pulse for 1800s, which is the worst-case scenario for estimating autonomy
$\bar{I}_{CH_da} = \frac{41.23 \times 1800 \times 10^{-3}}{1800} = 0.041mA$	$\bar{I}_{MN_sp} = \frac{39.58 \times 1800 \times 10^{-3}}{1800} = 0.039mA$	average consumption in sense-process mode for 1800ms pulse for 1800s, which is the worst-case scenario for estimating autonomy
$\bar{I}_{CH} = 40.37mA$	$\bar{I}_{MN} = 40.11$	Total Average consumption in CHs and MNs respectively.

to the pump to start the irrigation system. This software also accounts for SN-out-of-service faults from the CHs by indicating the MN- and CH-count of the received aggregated data. The main modules imported into the BS software include Socket, Bluetooth, sys, threading, time, csv, Queue, struct, ntplib, and gspread whereas the MN relied on Bluetooth, time, SCL and SDA from board, busio, and Seesaw from adafruit_seesaw.seesaw. The sensing code was also embedded in the bluetooth socket client code. The sensory data becomes the main parameter being transmitted at the crontab-scheduled timeslot to the BS at 3-hourly intervals.

copy of the received data to a .csv file in the project database in Github and Google sheet at Crontab-scheduled timeslots using low-power WiFi in the USA and the AirBox BE5E low-power WiFi device in Senegal. The BS-cloud communication standard will be replaced by LoRa in the future.

To validate the global significance of this research under variable operational conditions, our network was implemented and tested in two indoor conditions and two agricultural fields: one in Worcester, USA, and the other in Saint-Louis, Senegal-West Africa. During each deployment, the architecture underwent a series of modifications, the effects on performance were monitored, and the data were analyzed in later sections using MATLAB, OriginStudio, WebplotDigitizer, and MS Excel.

Overall, two clusters were implemented, each with 5 MNs during the indoor deployment phase and 4 MNs during the outdoor testing phase. The assembly of these network components with the circuitry accessories of a cluster is presented in Figure 7, while the test-bed in indoor testing/operational and outdoor/agricultural field operational modes are shown in Figures 9 and 10. In contrast to the outdoor deployments of the proposed CA-IoT with related real-world Agri-IoT solutions, as illustrated in Figure 10, it is evident that our solution (Figure 10a and Figure 10b) is easier and labor-saving to deploy, manage and scale it up by inexperienced users. Also, it is affordable, energy-efficient, simpler, less fault-vulnerable, and location-independent relative to the state-of-the-art (Figure 10c).

With the aid of Crontab-e, all network participants were duty-scheduled to sample and transmit their sensory data to the BS through their respective CHs at 3-hourly intervals. A conceptual data flow diagram with field data sampled by our CA-IoT network and stored on Google sheet is shown in Figure 11.

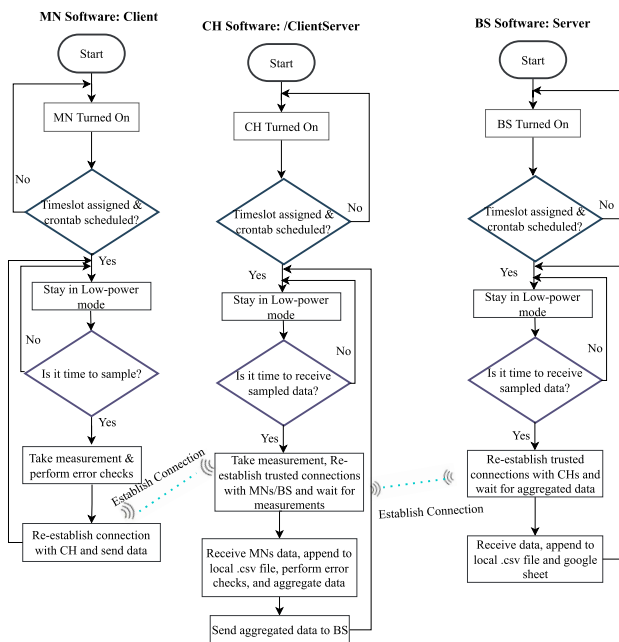

FIGURE 8. Flowcharts of the operational cycle of event routing software running on the MN, CH, and BS.

Because cloud data processing is beyond the scope of this study, the BS receives aggregated data in .csv file format for local processing, decision, and actuation, and appends a

C. THE BLE 4.2 AND WHY IT WAS SELECTED

As good engineering design is about making the right tradeoffs, the onboard BLE 4.2 module in RPi 3 B + was selected because it can operate at variable P_{Tx} in three cyclical

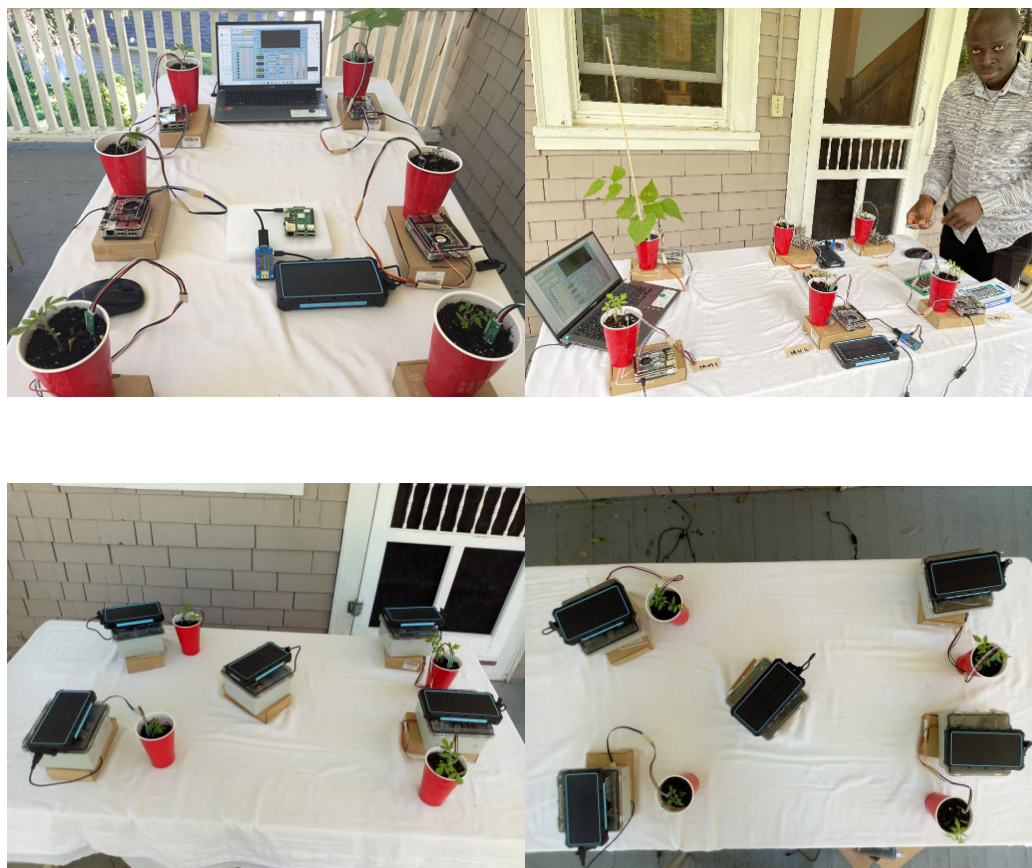

FIGURE 9. Proposed CA-IoT test-bed in full indoor operation mode.

phases (i.e., connection, data transfer, and sleep) to save more power. After connection, the BLE 4.2 transceiver stays either in an active mode or any low-power sleep mode: sniff mode, hold mode, and park mode. Unlike the ZigBee and Wi-Fi-based standards that support approximately 64,000 and 255 SN-count at extreme interference, BLE 4.2 supports less SN-count at least interference, making BLE-based CA-IoT a best/realistic option for agricultural environments. Additionally, BLE 4.2 has an embedded mechanism for mitigating interference from packets transmitted at the same time and frequency channels of other in-range coexisting wireless technologies such as WiFi and ZigBee (802.15.4 standards). This optimizes shared spectrum usage and significantly reduces the probability of collisions by balancing the range and throughput. Extra technical justifications for selecting BLE 4.2 version over LoRa, SigFox, and other versions of BLE include:

- 1) Enhanced IoT capabilities: BLE 4.2 supports low-power IP (IPv6/6LoWPAN) and Bluetooth Smart Internet Gateways (GATT), which allow smart sensors to transmit data over the Internet.
- 2) Improved security: It uses more power-efficient and highly secure features via LE Privacy 1.2 and LE secure

connections. It also provides additional benefits by allowing only trusted owners to track device locations and confidently pair devices.

- 3) Improved Speed: Compared to previous versions, BLE 4.2 enables 250% faster and more reliable over-the-air data transmission and ten times more packet capacity.
- 4) The BLE 4.2 module withstands extreme weather conditions and operational complexities, and supports previous versions and the cluster-based architecture with a faster reconnection time.

V. EXPERIMENTAL SETUP AND VALIDATION

A. EXPERIMENTAL SETUP

This CA-IoT solution has two indoor testing locations: the Wireless Innovation Laboratory (WILab) at Worcester Polytechnic Institute (WPI), USA, and Informatics Lab at Gaston Berger University (GBU), Senegal with the respective coordinates (42.27522717178471, -71.80710616500245) and (16.055929, -16.426720), and two outdoor implementation farms: a vegetable garden in Worcester, USA and a watermelon farm at GBU in Saint-Louis, Senegal, also with respective coordinates: (42.30305102130068, -71.76894003345) and (16.062547, -16.430407).



(a) Proposed Agri-IoT Technology Being Tested in a Farm in USA



(b) Proposed Agri-IoT Technology Being Tested in a Farm in Senegal

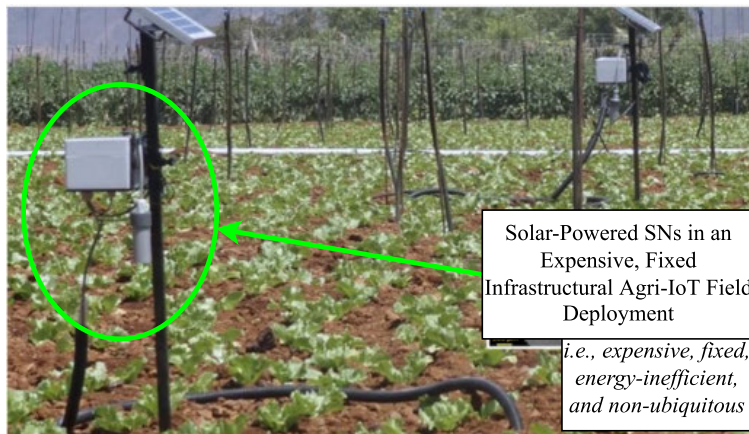

(c) Classic Agri-IoT Technology in Existing State-of-the-Art

FIGURE 10. Proposed CA-IoT test-bed in full outdoor operation modes contrasted with classic agri-IoT in the state-of-the-art.

The physical placement of the MNs, CHs, and BS to examine the performance efficiency of the proposed CA-IoT was constrained by the communication distance of the BLEs. A map showing the final physical placements of the network participants during outdoor deployment in both the USA and Senegal is illustrated in Figure 12. Before selecting the 10m as an ideal intra- and inter-cluster distance in Figure 12, a range variation assessment was conducted for two BLE

radios of an MN and a CH. As shown in Table 6, the threshold distance of the BLE radios that guaranteed stable connectivity with the least interference and high event data delivery rate ranged between 8m -10m, which agrees with the sensing coverage requirements of the soil [16], [17]. Therefore, 10m was selected to achieve a perfect range overlap and wider farm coverage. However, this can be guaranteed if power depletion does not exceed 30% of the rated capacity.

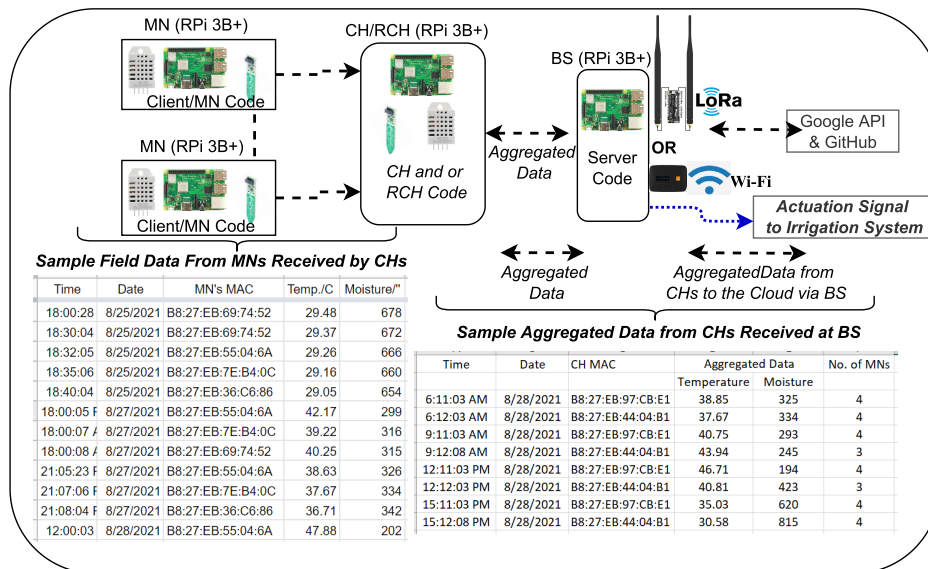

FIGURE 11. Data flow model of our CA-IoT network with sample measurements.

The maximum intra-cluster distances with zero packet drops for the BLEs were found to be 12m and 11.5m in USA and Senegal, respectively. However, these values do not minimize packet drops, overhearing, and connectivity failures when the power supplies drop below certain thresholds (*i.e.*, the transmitter power depends on the communication distance, packet size, transmission medium, and transmission duration [8], [36]).

The overall deployment process of the proposed CA-IoT network, as conceptualized in Figure 11, is divided into four steps.

- 1) The first step precedes the assembly of hardware components, installation of all libraries, and development of BLE-based event sampling and routing protocol/software, which have been comprehensively captured in our founding test-bed paper [55]. In this step, static nodes are deployed in a suitable range locations using the cluster quality estimation technique in [29] and BLE radio RSSI levels were estimated. As depicted in Figures 9 and 10, the network consists of a BS and two clusters, each with five MNs and a CH in the indoor environment, and four MNs each in outdoor or agricultural environments. Since solar-rechargeable power banks powered all the network participants, their installation stands were raised above the crops to avoid any possible shading.
- 2) During the second step, the participants were activated and clustered, and the 3-hourly sampling times were scheduled by the software using the onboard cron-tab-e of the RPi 3 B +.
- 3) In the third step, the actual experiment occurs where the MNs transmit their sampled data to the BS via their respective CHs for processing, actionable decisions, cloud database updates, and actuation of the control

relay of the irrigation system. Both CH and BS locally store copies of the received field data (*i.e.*, soil temperature and moisture data) in a .csv file, and log the time, date, and MAC address of the sender. The CHs send their aggregated data to the BS, which also logs the date, time, MAC address, the MN-count of the received data, and updates the project Github database and Google sheet, as shown in Figure 11.

- 4) To sufficiently evaluate the network's performance stability under variable intra-cluster communication distances or architectural alterations, extreme climatic conditions, and variable participant activity durations, the above steps were repeated under variable conditions to observe the effects on the network's lifespan data and sampled data quality.

B. FIELD INSTALLATION PRECAUTIONS AND STEPS

The CA-IoT network installed in its normal operating mode in the outdoor environments is illustrated in Figure 10a and Figure 10b. Because the crops in the farms can attenuate the BLE radio signal transmission efficiency of the network participants (*i.e.*, MNs, CHs, and BS), the field installation stands were raised above the crops (Figure 10). The height of a stand must always depend on the height of the crops on the farm. The MNs, CHs, and BS were correctly installed such that the solar panels faced the true-south direction to ensure ample access to sunlight.

As shown in Figure 9, the network participant casings are of marginal sizes (*i.e.*, an outer size of 5.9" × 5.9" × 3.5"/150mm × 150mm × 90mm (L × W × H)), hence they require marginal farm space without the need for panels co-location, or any capacity to reduce crop production capacities and quality. As opposed to the state-of-the-art conventional

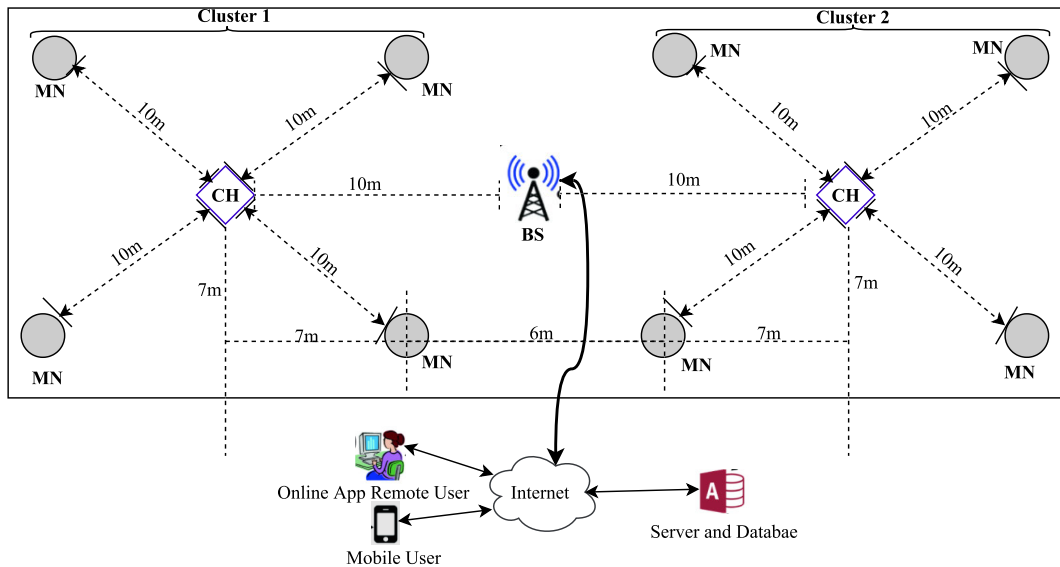

FIGURE 12. A map showing outdoor experimental setup of proposed CA-IoT network.

Agri-IoT, the field installation of our affordable WSN-based Agri-IoT was very simple for non-experts and poor farmers as well as labor-saving. This was attested to by the watermelon farmer who helped us install the network in Senegal. This involves the following two steps:

- 1) The stands were installed at an appropriate height, location, and inclination to ensure ample access to sunlight.
- 2) Placing the Agri-IoT participants in their respective stands, installing the sensors in the soil, switching them ON, and monitoring the periodic measurements remotely. The stored measurements on the BS can also be monitored remotely on a farm using the VNC viewer.

Unlike the classic Agri-IoT in Figure 10c, the field installation of the 11 wireless network participants, forming the proposed CA-IoT network, takes approximately 20 min and less than 10 min to uninstall because there is no need to install any expensive and complex wired-based or fixed infrastructure.

C. PROPOSED CA-IOT PERFORMANCE ASSESSMENT AND MONITORING TOOLS

The following tools were used to assess and record the impacts of the aforementioned parametric variations on the performance of proposed CA-IoT network:

- 1) 3-Axis RF Field Strength Meter was used to monitor the variations in the radiated power levels of the BLE radio signal to unravel ideal intra- and inter-cluster distances.
- 2) The Kuman Electricity Usage meter was used to measure the indoor power consumption variations of the MNs, BS, and CHs during different operational modes (i.e., transmit, receive, idle, standby, and sleep

or off modes) to establish SNs’ battery capacities and automation span of SNs.

- 3) UM25C, TypeC USB2.0 Full-Color LCD Display Multimeter Tester was used to remotely monitor and record participants’ principal performance parameters such as energy, current, voltage, power, and ambient temperature in both °C and °F. It is a Bluetooth-enabled USB dongle sandwiched between the power supply and the RPI 3 B + modules to simultaneously monitor the input voltage, current, power, energy, and ambient temperature in the casings. The PC software of UM25C offers a real-time graphical view of the RPI’s ambient temperature and energy consumption (i.e., Current/mA and voltage/v), recording these parameters, and the ability to extract them into .csv files for further analysis.

The 3-Axis RF Field Strength Meter was used to estimate the BLE signal strength under both indoor and outdoor operational environment so that the intra- and inter-cluster distances required by the MNs, CH and BS operate without packet drops can be determined. The Kuman Electricity Usage meter also helped to estimate the power consumption requirements when the nodes were operated in different states. The performance assessment results of the network participants are illustrated in Table 6. The results showed that the inter-participant distance varies from one environment to another. Since BLE is a short-ranged communication technology, it was practically impossible implementing this technology using the centralized architecture. Thus, the network experienced severe packet drops when operated using the centralized. This makes the novel CA-IoT approach the best candidate for implementing robust, energy-efficient and affordable Agri-IoT solutions on large-scale farms. Additionally, unlike the centralized architecture which gave

TABLE 6. Impact assessment of intra-cluster distance variations on Agri-IoT network's performance.

Intra-cluster distance/m distance/m	Packet drop? (USA, Senegal)	Stable BLE connectivity? (USA, Senegal)	All MNs sampled? (USA, Senegal)	Battery Power $\geq 70\%$? (USA, Senegal)
1	✓✓	✓✓	✓✓	✓✓
:	:	:	:	:
5	✓✓	✓✓	✓✓	✓✓
5	✓✓	✓✓	✓✓	××
6	✓✓	✓✓	✓✓	✓✓
6	✓✓	✓✓	✓✓	××
7	✓✓	✓✓	✓✓	✓✓
7	✓✓	✓✓	✓✓	××
8	✓✓	✓✓	✓✓	✓✓
8	✓✓	✓✓	✓✓	××
9	✓✓	✓✓	✓✓	✓✓
9	✓×	✓×	✓×	××
10	✓✓	××	✓×	✓✓
10	××	××	××	××
11	✓✓	××	✓×	✓✓
11	××	××	××	××
12	✓✓	××	✓×	✓✓
12	××	××	××	××
:	:	:	:	:
:	:	:	:	:
15	××	××	××	✓✓
15	××	××	××	××

no results, the distance and data moderation by the CHs made the CA-IoT operated with packet transmission results as well as prolonged network lifespan.

Once these crucial values were determined for a given environment, the UM25C multimeter was used to remotely monitor the aforementioned parameters for power dissipation analysis, which is shown in the next section.

VI. RESULTS AND DISCUSSIONS

Since the effects of all the aforementioned performance parameters beyond network deployment culminate in a node's availability or lifespan, this section discussed the key modalities for ensuring nodes' energy efficiency. This is necessary for achieving the context relevance of this paper.

The pre-indoor/outdoor testing of our founding test-bed in [9] helped unravel key deployment parameters, such as BLEs' surface power variations/behavior with respect to communication distance, required participants' worst-case CPU and memory capacities, participants power consumption variations with respect to BLE states, and optimal data rates of an MN and a CH. This processes need not to be repeated because our CA-IoT network architecture was adapted from the same test-bed. Consequently, the key metrics used to evaluate the performance of this network are the intra-cluster distance and ambient environmental conditions of the participants. The latter metric helped validate the global significance of the proposed network.

First, the intra-cluster communication distance ($d_{intra-c}$) was varied at a 70% threshold power, and the resulting impacts on packet drop, stability of BLE connections,

and event reporting accuracy are illustrated in Table 6. The 70% power threshold was agreed upon because we observed unstable packet transmissions during the testing phase, which required a reduction in intra-cluster distance whenever power was depleted below this threshold value. Similarly, to define an optimal SNs deployment density and intra- and inter-cluster distances that can guarantee optimal connectivity and eliminate interference without compromising event data quality, the surface power density from the antenna of the BLE module was measured at constant transmission power but at different distances from the SN, as illustrated in Table 6. It can be established from Table 6 that variations in weather conditions greatly affect BLE radio connectivity and the tendency of packet losses. Thus, unlike the deployment in the USA, the high temperatures and dust concentration levels affected BLE radio connectivity and packet delivery rates in Senegal at distances beyond 8m. Carrying out the same experiment below the 70% power threshold will reduce this distance to guarantee the desired BLE connectivity at the expense of reduced farm coverage. By implication, the proposed CA-IoT is not limited to any ideal intra- and inter-cluster distance. For every environment, these parameters must be determined. To eliminate the impacts physical obstructions on BLE radio connectivity and packet delivery rates, we ensured that the nodes' stands are raised above all plants in the farm.

It should be noted that each CH, at this stage supervised at most four (4) or five (5) MNs. Because the maximum cluster-size thresholds of the CHs were not attained, both

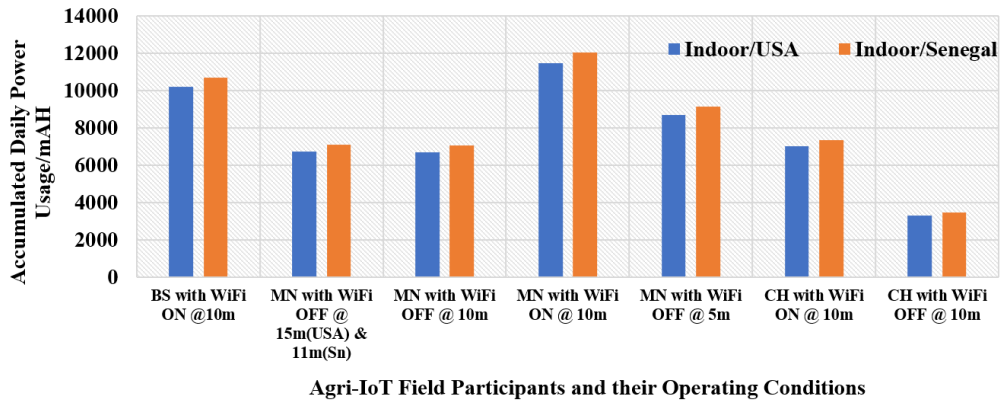

FIGURE 13. Comparing CA-IoT participants’ accumulated daily power consumptions at varying operating modes and $d_{intra-c}$ under indoor conditions.

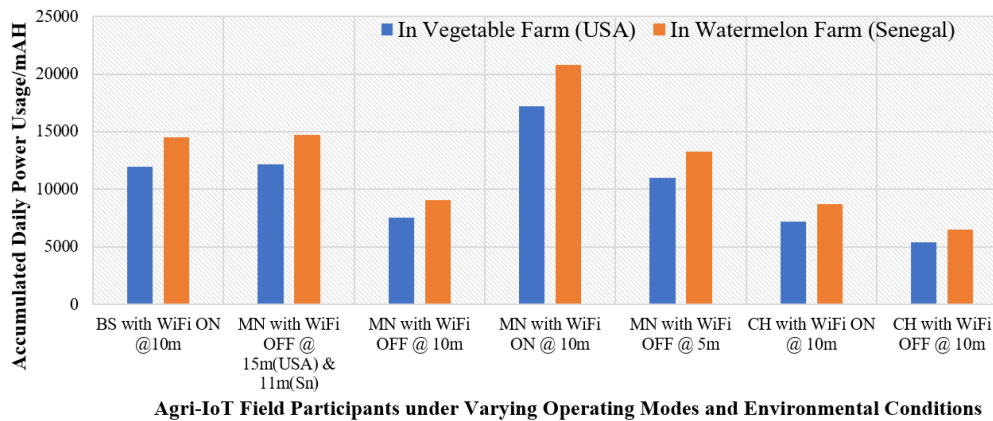

FIGURE 14. Comparing CA-IoT participants’ accumulated daily power consumptions at varying operating modes and $d_{intra-c}$ under outdoor conditions.

channel interfacing packets and event packets experienced zero latency and packet drops or interference.

Furthermore, to ascertain the robustness, performance stability, global significance, and potential risk factors that can hinder the performance efficiency of the proposed CA-IoT network, the network was deployed and tested under different environmental conditions in the USA and Senegal. The effects of these performance variations were observed using a participant’s lifespan metric (thus, real-time instantaneous and accumulated power consumption), which was monitored in real-time using the UM25 multimeter USB dongles. This is an ideal, contextualized performance evaluation measure because most related Agri-IoT test-beds solutions operated well only in ideal indoor/laboratory environmental conditions and malfunctioned under real-world outdoor environmental conditions owing to some possible climatic extremes. Consequently, our CA-IoT network was tested under these dual environmental conditions to justify its global significance, and the results from both indoor and outdoor implementations are presented in Figure 13 and Figure 14, respectively. Additionally, the broader environmental disparities, in terms

of the severity of temperature, humidity, and atmospheric dust concentration levels between these locations and the capacity of the proposed CA-IoT network to withstand these adverse conditions make it globally significant to the Agri-IoT community. The proposed network performed up to expectations during a 2-month farm testing in the USA and Senegal.

According to Figures 13 and 14, operating the network participants with their Wi-Fi or VNC servers in the ON state results in higher accumulated daily power depletion than when the Wi-Fi modules remain in the OFF mode under both indoor and outdoor environmental conditions in the two countries. However, because the MNs and CHs do not require WiFi modules except the BS, they must be switched OFF. Additionally, it can be deduced from Figure 13 and Figure 14 that the optimal intra- and inter-cluster distances for our CA-IoT technology are 10m. However, this requires a more stable power supply because the reliability of the BLEs’ connectivity depends on the communication distance. Therefore, network participants were installed at 10m apart. However, we observed a high

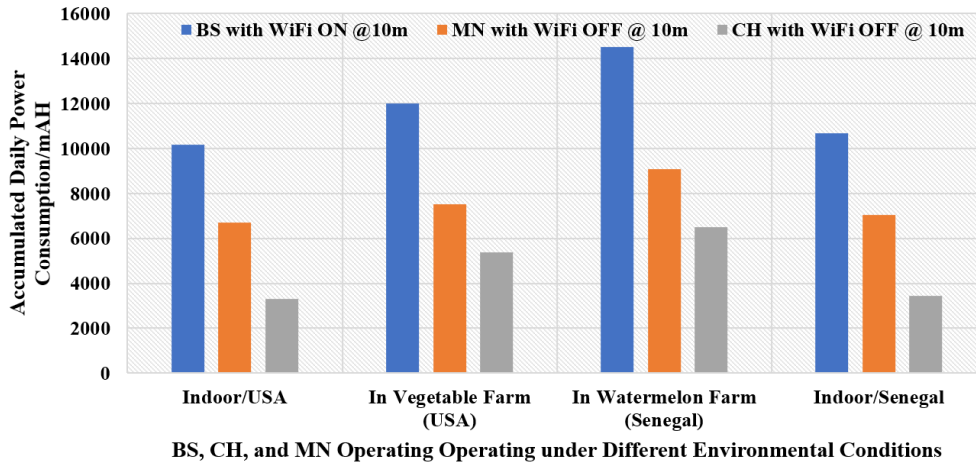

FIGURE 15. Comparing accumulated daily power consumptions of MN, CH, and BS under varying outdoor environmental conditions when $d_{intra-c}$, $d_{inter-c} = 10m$.

rate of packet drops and sampling failures at any time when the power supplies of CHs, MNs, and BS dropped below 70% of their capacities, as shown in Table 6. Although the proposed CA-IoT technology performed well under all operating circumstances without participant/component failures on a normal day, it can be observed from Figure 13 and Figure 14 that participants' power depletion rates under the same intra- and inter-cluster distances and environmental conditions in Senegal were higher than those in the USA. This can be attributed to Senegal's relatively high ambient climatic extremes and dust concentrations. For instance, the participants' ambient temperature ranges in the USA and Senegal were 18°C-31°C and 34°C-50°C, respectively, which compelled the cooling fans to be active most times during field deployment in Senegal.

In addition, an inter-participant distance of 10m requires that the power supply is stably maintained above 70% of the battery capacity. However, it was observed from the outdoor implementation in Senegal that the rate of battery discharge is more than the rate of its recharge even at peak-sun-hours (PSH), which implies that anytime the batteries discharge, the entire network must be switched OFF for recharging. From Figure 15, it can also be deduced that the percentage of accumulated power depletion of BS, CH, and MN in Senegal is approximately 33%, 15%, and 25% for a normal day, which can lead to abrupt power exhaustion during prolonged rainstorms or days without ample sunlight. Again, indoor and outdoor power consumption recorded in Senegal were higher than those recorded in the USA owing to extreme ambient conditions in Senegal. This challenge was remedied during field testing by replacing the built-in solar panels with a relatively higher-rated one.

Finally, the daily power depletion patterns of BS, CHs, and MNs in their respective normal operation modes were monitored when the CA-IoT network was operated under different environmental conditions in the USA and Senegal,

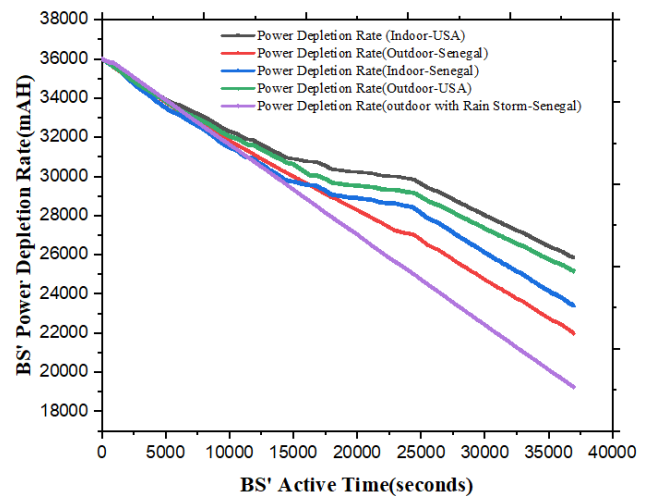

FIGURE 16. Sample BS' power depletion patterns under varying climatic conditions (at $d_{intra-c} = 10m$).

as shown in Figure 16, Figure 17, and Figure 18, respectively. These results also confirm that the relative power depletion rates of the CA-IoT participants in Senegal are higher for the reasons mentioned above. The power depletion values significantly exceed the theoretical estimations obtained under ideal conditions. During the field testing in Senegal, two heavy downpours were experienced, one lasting for the entire day and the other for the entire night. As illustrated in Figure 17, and Figure 18, the CHs and MNs consumed extra power to maintain the BLE connectivity. The CHs and BS can switch to the power-saving mode during such circumstances to conserve their energies, hence, the results in Figures 16 and 17. However, as illustrated in Figure 18, the MNs depleted all their power and remained in the OFF mode until their batteries were recharged the next day. This is a critical risk factor for the operational stability of our CA-IoT network, which was not given sufficient consideration during

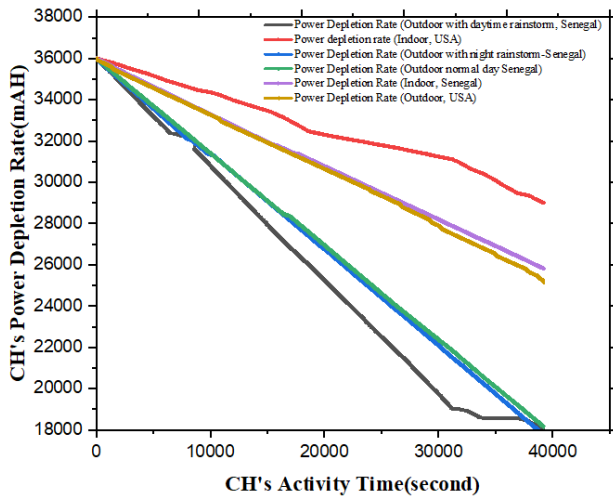

FIGURE 17. Sample CHs' power depletion patterns under varying climatic conditions (at $d_{intra-c} = 10m$).

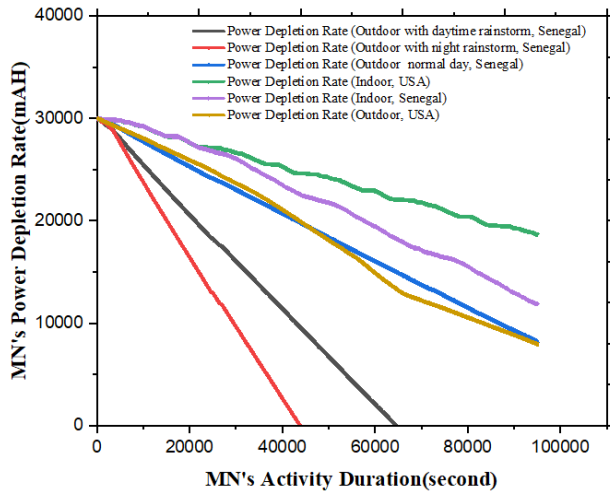

FIGURE 18. Sample MNs' power depletion patterns under varying climatic conditions (at $d_{intra-c} = 10m$).

battery sizing in the SN design phase hence, the next phase of this project will address it.

In addition, it was discovered that the outputs of onboard solar systems were insufficient to recharge the batteries as indicated by the designers. When two onboard solar systems (with ratings 2.2W/5V/0.44A) of a CH and an MN were replaced with an 8W/10V/0.80A rated panel during the field deployment in Senegal, we observed a more stable performance under all conditions. This is because the batteries remained in full capacity during the day and only depleted during the night. In summary, it was observed that the performance stability of our solution could be significantly improved by increasing the capacities of onboard solar systems. The performance efficiency of the proposed CA-IoT solution can be affected when it is operated outside its allowable climatic threshold. Moreover, since the soil parameters being monitored do not change significantly

at night, this network, in the future, will be programmed not to sample between 21 h and 06 h during field deployment phases so that the MNs, CHs, and the BS can switch to low-power listening mode to improve their lifespan.

It is evident from the proposed network supervisory protocol that CA-IoT network participants are operationally independent. Consequently, SN-out-of-service faults were auto-detected and self-healed or tolerated without affecting the normal operation of the rest of the network. Additionally, with the aid of the threshold-based fault tolerance algorithms that were previously proposed in [13] and [52] and implemented in the sampling and routing software, all readings outside the measurement range of the sensors were classified as data outliers and dropped at either an MN-level or a CH-level. In addition to the unmatched networks auto-adaptability mechanisms, the proposed CA-IoT network can also be easily scaled by simply adding a new MN to a cluster at any suitable in-range location and trusting the MN—CH connection in the *Bluetoothctl* console.

Although the CA-IoT outperformed relation solution, the proposed technology was implemented using only 11 nodes on a half acre piece of land. Thus, the CA-IoT technology is cheaper and robust, however, there exist the need to scale it up with more nodes and tasks and deploy it on-farm for at least two year to validate its practical viability to the farmers (end-users). This will help to uncover more risk factors that can be addressed to enhance its commercial viability. Additionally, a more robust multihop routing protocol will be required so it can cover more space in future research. Once these are addressed, the reliably sampled data can be used to automate greenhouses and enhance precision farming economically.

Detailed observations during the field deployment and testing of the CA-IoT are presented in the following subsections.

A. FIELD OBSERVATIONS AND DISCUSSIONS

The proposed CA-IoT network was deployed in a vegetable farm without an installed irrigation system in the USA and in a watermelon farm with an installed irrigation system in Senegal, which made it easier to control by incorporating a normally open relay switch into the irrigation control system. The following observations were made during the deployment and testing phase in both Senegal and the USA:

- 1) The indoor deployment worked efficiently without any challenges such as connectivity failures, packet drops, faulty measurements, abrupt SN failure, and SN-out-of-service when the intra-cluster distances were varied from 1m to 12m. On the contrary, the intra-cluster distance of the outdoor deployments that ensured more stable connectivity without packet drops was 10m. This was maintained only when the battery capacity was above 70% as $P_{Tx} \propto d^\alpha$, where α depends on the pre-established ambient atmospheric conditions.
- 2) After a prolonged heavy downpour on a particular night, the network participants experienced abrupt failures due to battery exhaustion because higher power

was demanded to sustain the intra-and inter-cluster BLE connectivities during this high humidity period. A similar rainstorm that lasted for 4 h during the day resulted in average power depletion of 40%. This implies that prolonged rainstorms could be a potential risk factor in our network.

- 3) In Senegal, network participants operated well at extreme temperatures ranging from 45°C to 50°C, which melted the double-sided tapes holding the power banks to the casings. Generally, power depletion in outdoor environments is faster than in indoor environments, and power is usually depleted faster in Senegal than in the USA owing to extreme climatic conditions. Additionally, under controlled indoor environments, we observed very gentle power depletion patterns (i.e., it took 18 h to deplete to 70% of the battery capacity). However, the power depleted rapidly in the outdoor environment. Thus, it took approximately 9 h for the power to deplete to 80% of the battery capacity even when the network was operated in continuous recharging mode in agricultural environments due to extreme weather conditions (e.g., 50°C ambient temperature), resistance to signal transmission caused by dust, and physical obstructions, such as crops.
- 4) The average battery recharging durations of MN, CH, and BS during the active and OFF/inactive modes are 8 and 5 h, respectively. Additionally, it was evident that the rate of battery discharge was faster than the rate of recharge even at peak-sun-hours (PSH), which implies that at any time the battery discharge, the entire network must be switched OFF for recharge. Thus, the onboard solar panels of the power banks could produce less than 50% of their rated output at PSH, and so, they could not recharge the batteries, as estimated. This challenge was remedied during field testing using a relatively high rated panel.

Overall, it is evident from the results that the prevailing weather condition is a critical performance indicator for the proposed CA-IoT technology that needs future research consideration. This will help determine the ideal operational domains in terms of power and inter-SN distance requirements for ensuring the desired packet delivery rates and BLE connectivity under every context. Although this study revealed extreme humidity and dust concentrations as part of these indicators, further research can help establish other indicators and their thresholds. Regarding auto-adaptability to faults and SN failures, the embedded routing software handled them efficiently. Additionally, due to time and financial constraints, only 11 SNs were developed and deployed for a few months on the field. However, to justify the commercial viability of the CA-IoT, the SN-count, deployment durations, and probably, the SN task must be scaled up. Unlike the aforementioned testbed studies [3], [5], [14], [15], [16], [17], [37], [38], [39], [40], [41], [42], [43] that focused on just building workable real-world Agri-IoT solutions using classical IoT design principles and technologies without

real-world performance data sampling and data processing, this study proposed and custom-built a robust, affordable, context-relevant and globally significant Agri-IoT remedy with prototypes and unique indoor and outdoor performance results. Since the effects of all the critical design metrics (i.e., FM, adaptability and power consumption optimization) are manifested in SN lifespan (SN-Out-of-Service) and data outlier, of which the later was auto-addressed by the embedded routing protocol, the power depletion rate or SN lifespan remained our principal real-time performance metric. Thus, using similar hardware components, this study in its novelty presents a reference Agri-IoT routing protocol for the CA-IoT architecture with task-scalable prototypes and a unique performance assessment technique.

VII. CONCLUSION

In this study, a context-relevant hardware evaluation of an adaptive CA-IoT network for precision farming and greenhouses that is robust, cheap, task- and size-scalable, infrastructure-less, location-independent, and fault-tolerant was custom-built and tested. A sample performance evaluation results provide a realistic account of how to exploit the merits of the emerging BLE communication technology and clustering topology to attain the desired energy savings, network management, fault tolerance, network lifespan, operational efficiency, and event data quality in CA-IoT networks. Additionally, this network exhibits high operational simplicity and flexibility for inexperienced users, which makes it possible to scale up SNs activities and SN-count/network-size via simple commands to provide rich set measurements for educational and outdoor purposes. Although our context-relevant Agri-IoT solution with custom-built prototypes has proven to be operationally robust, affordable, fault-tolerant, infrastructure-less, adaptive/scalable, and simple to deploy and manage anywhere by non-experts, the initial testing excluded the end-users (farmers) and relied on inadequate testing nodes and duration due to time and financial constraints, which invalidated the commercial viability of this solution. Therefore, there exist the need to scale it up with more nodes and tasks and perform on-farm testing for at least two years to validate its commercial viability to the farmers (end-users). This will help to uncover more risk factors besides unfavorable weather conditions. Additionally, a more robust multihop routing protocol will be required so it can cover more space in future research. Furthermore, our CA-IoT solution exhibited unprecedented global significance because it performed efficiently under indoor and outdoor environmental conditions in the USA and Senegal in West Africa. The impact of climatic extremes, such as prolonged rainstorms, on the performance of proposed CA-IoT network requires further research. Furthermore, with the help of the established theoretical foundations, this study can be extended by adding soil nutrient sensors and cameras for remote monitoring of farms in future scope. Sampling and processing data on several soil factors, such as soil temperature, soil moisture, and humidity, with the aid of our

solution will help to forecast irrigation appropriateness and farm resources optimization.

ACKNOWLEDGMENT

The views expressed herein do not necessarily reflect the official opinions of the donors.

REFERENCES

- [1] S. Tauseef, J. Nadeem, and Q. Talha, "Energy efficient sleep awake aware (EESAA) intelligent sensor network routing protocol," in *Proc. Int. Multiprotocol Conf. (INMIC)*, Dec. 2012, pp. 317–322.
- [2] P. Gennari and J. R. Moncayo, *World Food and Agriculture Statistical Pocketbook*, vol. 1. Geneva, Switzerland: FAO of the UN, 2018, pp. 1–248.
- [3] R. Hartung, U. Kulau, B. Gernert, S. Rottmann, and L. Wolf, "On the experiences with testbeds and applications in precision farming," in *Proc. 1st ACM Int. Workshop Eng. Reliable, Robust, Secure Embedded Wireless Sens. Syst.*, Nov. 2017, pp. 54–61.
- [4] E. Effah, O. Thiare, and A. Wyglinski, "Multi-objective optimization modeling of clustering-based agricultural Internet of Things," in *Proc. IEEE 92nd Veh. Technol. Conf. (VTC-Fall)*, Nov. 2020, pp. 1–5, doi: [10.1109/VTC2020-Fall49728.2020.9348460](https://doi.org/10.1109/VTC2020-Fall49728.2020.9348460).
- [5] R. Khan, I. Ali, M. Zakarya, M. Ahmad, M. Imran, and M. Shoab, "Technology-assisted decision support system for efficient water utilization: A real-time testbed for irrigation using wireless sensor networks," *IEEE Access*, vol. 6, pp. 25686–25697, 2018, doi: [10.1109/ACCESS.2018.2836185](https://doi.org/10.1109/ACCESS.2018.2836185).
- [6] B. Shiferaw, K. Tesfaye, M. Kassie, T. Abate, B. M. Prasanna, and A. Menkir, "Managing vulnerability to drought and enhancing livelihood resilience in sub-saharan Africa: Technological, institutional and policy options," *Weather Climate Extremes*, vol. 3, pp. 67–79, Jun. 2014.
- [7] P. Mitra, F. Unsal, M. Farid, L. Kemoe, D. Fayad, J. Spray, C. Okou, D. M. S. Baptista, L. Lanci, T. Muehlschlegel, and K. Tuitoek, "Climate change and chronic food insecurity in sub-Saharan Africa," *Departmental Papers*, vol. 2022, no. 16, pp. 1–48, Sep. 2022.
- [8] E. Effah, O. Thiare, and A. Wyglinski, "Energy-efficient multihop routing framework for cluster-based agricultural Internet of Things (CA-IoT)," in *Proc. IEEE 92nd Veh. Technol. Conf. (VTC-Fall)*, Nov. 2020, pp. 1–5, doi: [10.1109/VTC2020-Fall49728.2020.9348608](https://doi.org/10.1109/VTC2020-Fall49728.2020.9348608).
- [9] E. Effah, O. Thiare, and A. M. Wyglinski, "A tutorial on agricultural IoT: Fundamental concepts, architectures, routing, and optimization," *IoT*, vol. 4, no. 3, pp. 265–318, Jul. 2023.
- [10] M. Haenggi and D. Puccinelli, "Routing in ad hoc networks: A case for long hops," *IEEE Commun. Mag.*, vol. 43, no. 10, pp. 93–101, Oct. 2005.
- [11] M. Haenggi, "Twelve reasons not to route over many short hops," in *Proc. IEEE Veh. Technol. Conf.*, Sep. 2004, pp. 1–4.
- [12] A. McBratney, B. Whelan, T. Ancew, and J. Bouma, "Future directions of precision agriculture," *Precision Agricult.*, vol. 6, pp. 7–23, Feb. 2005, doi: [10.1007/s11119-005-0681-8](https://doi.org/10.1007/s11119-005-0681-8).
- [13] E. Effah and O. Thiare, "Realistic cluster-based energy-efficient and fault-tolerant (RCEEFT) routing protocol for wireless sensor networks (WSNs)," in *Advances in Information and Communication*. Cham, Switzerland: Springer, 2020, pp. 320–337.
- [14] K. Langendoen, A. Baggio, and O. Visser, "Murphy loves potatoes: Experiences from a pilot sensor network deployment in precision agriculture," in *Proc. 20th IEEE Int. Parallel Distrib. Process. Symp.*, Apr. 2006, pp. 8–13, doi: [10.1109/IPDPS.2006.1639412](https://doi.org/10.1109/IPDPS.2006.1639412).
- [15] N. Ahmed, D. De, and I. Hussain, "Internet of Things (IoT) for smart precision agriculture and farming in rural areas," *IEEE Internet Things J.*, vol. 5, no. 6, pp. 4890–4899, Dec. 2018, doi: [10.1109/JIOT.2018.2879579](https://doi.org/10.1109/JIOT.2018.2879579).
- [16] H. Jawad, R. Nordin, S. Gharghan, A. Jawad, and M. Ismail, "Energy-efficient wireless sensor networks for precision agriculture: A review," *Sensors*, vol. 17, no. 8, p. 1781, Aug. 2017, doi: [10.3390/s17081781](https://doi.org/10.3390/s17081781).
- [17] S. Bhandari, A. Raheja, M. R. Chaichi, R. L. Green, D. Do, F. H. Pham, M. Ansari, J. G. Wolf, T. M. Sherman, and A. Espinas, "Lessons learned from UAV-based remote sensing for precision agriculture," in *Proc. Int. Conf. Unmanned Aircr. Syst. (ICUAS)*, Jun. 2018, pp. 25686–25697, doi: [10.1109/icuas.2018.8453445](https://doi.org/10.1109/icuas.2018.8453445).
- [18] E. Effah and W. Dorgloh, "GSM-controlled irrigation system (GSMCIS) for vegetable farmers in Ghana," *Ghana J. Technol.*, vol. 1, no. 1, pp. 21–24, 2016.
- [19] H. Devi Kotha and V. Mnssvkr Gupta, "IoT application, a survey," *Int. J. Eng. Technol.*, vol. 7, no. 2, pp. 891–896, Mar. 2018.
- [20] M. Stoč es, J. Vaněk, J. Masner, and J. Pavlík, "Internet of Things (IoT) in agriculture—Selected aspects," *Agris On-Line Papers Econ. Informat.*, vol. 8, no. 1, pp. 83–88, Mar. 2016.
- [21] K. Lova Raju and V. Vijayaraghavan, "IoT technologies in agricultural environment: A survey," *Wireless Pers. Commun.*, vol. 113, no. 4, pp. 2415–2446, Aug. 2020.
- [22] M. S. Farooq, S. Riaz, A. Abid, K. Abid, and M. A. Naeem, "A survey on the role of IoT in agriculture for the implementation of smart farming," *IEEE Access*, vol. 7, pp. 156237–156271, 2019.
- [23] M. Abbasi, M. H. Yaghmaee, and F. Rahnama, "Internet of Things in agriculture: A survey," in *Proc. 3rd Int. Conf. Internet Things Appl. (IoT)*, Apr. 2019, pp. 1–12.
- [24] N. A. M. Leh, M. S. A. M. Kamaldin, Z. Muhammad, and N. A. Kamarzaman, "Smart irrigation system using Internet of Things," in *Proc. IEEE 9th Int. Conf. Syst. Eng. Technol. (ICSET)*, Oct. 2019, pp. 96–101.
- [25] N. Divya, E. A. Das, R. H. Prasath, R. Janani, B. Kaviya, and K. Lakshmi, "IoT based smart irrigation system," in *Proc. Int. Conf. Comput., Power Commun. (ICCCPC)*, Dec. 2022, pp. 7–11.
- [26] M. L. Rajaram, E. Kougiannos, S. P. Mohanty, and U. Choppali, "Wireless sensor network simulation frameworks: A tutorial review: MATLAB/Simulink bests the rest," *IEEE Consum. Electron. Mag.*, vol. 5, no. 2, pp. 63–69, Apr. 2016.
- [27] M. Elleuchi, M. Boujelben, M. S. BenSaleh, A. M. Obeid, and M. Abid, "Tree based routing protocol in WSNs: A comparative performance study of the routing protocols DEEC and RPL," *Future Technol. Publications*, vol. 5, no. 1, pp. 7–16, 2016.
- [28] W. Bank, "Access to electricity (% of population)—sub-Saharan Africa," in *The World Bank and UN Data on SSA*. R. Grynspan, 2021, pp. 1–3.
- [29] E. Effah and O. Thiare, "Estimation of optimal number of clusters: A new approach to minimizing intra-cluster communication cost in WSNs," in *Proc. GRIET*, Hyderabad, India, Aug. 2018, pp. 1–4.
- [30] O. Younis and S. Fahmy, "HEED: A hybrid, energy-efficient, distributed clustering approach for ad hoc sensor networks," *IEEE Trans. Mobile Comput.*, vol. 3, no. 4, pp. 366–379, Oct. 2004.
- [31] Q. Nadeem, M. B. Rasheed, N. Javaid, Z. A. Khan, Y. Maqsood, and A. Din, "M-GEAR: Gateway-based energy-aware multi-hop routing protocol for WSNs," in *Proc. 8th Int. Conf. Broadband Wireless Comput., Commun. Appl.*, Oct. 2013, pp. 164–169.
- [32] L. Qing, Q. Zhu, and M. Wang, "Design of a distributed energy-efficient clustering algorithm for heterogeneous wireless sensor networks," *Commun. Commun.*, vol. 29, no. 12, pp. 2230–2237, 2006.
- [33] A. K. Dwivedi, S. Kushwaha, and O. P. Vyas, "Performance of routing protocols for mobile adhoc and wireless sensor networks: A comparative study," *Int. J. Recent Trends Eng.*, vol. 2, no. 4, pp. 101–105, 2009.
- [34] K. S. H. Kalkha and H. Satori, "Performance evaluation of AODV and LEACH routing protocol," *Adv. Inf. Technol., Theory Appl.*, vol. 1, no. 1, pp. 113–118, 2016.
- [35] M. Iqbal, M. Naeem, A. Anpalagan, A. Ahmed, and M. Azam, "Wireless sensor network optimization: Multi-objective paradigm," *Sensors*, vol. 15, no. 7, pp. 17572–17620, Jul. 2015.
- [36] J. Bredin, E. Demaine, M. Hajiaghayi, and D. Rus, "Deploying sensor networks with guaranteed capacity and fault tolerance," in *Proc. MobiHoc*, 2005, pp. 309–319.
- [37] R. V. Saraswathi, J. Sridharani, S. Chowdary, K. Nikhil, M. S. Harshitha, and K. M. Sai, "Smart farming: The IoT based future agriculture," in *Proc. 4th Int. Conf. Smart Syst. Inventive Technol. (ICSSIT)*, Jan. 2022, pp. 150–155.
- [38] B. SakthiKumar, M. I. Niranjana, M. Abinath, I. G. Prasath, K. Jugasri, and S. Kailash, "Survey on smart agriculture using iot," in *Proc. Int. Conf. Comput. Commun. Informat. (ICCCI)*, Jan. 2023, pp. 1–5.
- [39] S. R. Prathibha, A. Hongal, and M. P. Jyothi, "IoT based monitoring system in smart agriculture," in *Proc. Int. Conf. Recent Adv. Electron. Commun. Technol. (ICRAECT)*, Mar. 2017, pp. 81–84.
- [40] A. Preethi and P. K. Reddy, "Survey on smart agriculture a roadmap for india: Role of IoT, AI," in *Proc. 3rd Int. Conf. Electron. Sustain. Commun. Syst. (ICESC)*, Aug. 2022, pp. 434–439.
- [41] M. S. Mekala and P. Viswanathan, "A survey: Smart agriculture IoT with cloud computing," in *Proc. Int. Conf. Microelectron. Devices, Circuits Syst. (ICMDCS)*, Aug. 2017, pp. 1–7.

- [42] X. Yang, L. Shu, J. Chen, M. A. Ferrag, J. Wu, E. Nurellari, and K. Huang, "A survey on smart agriculture: Development modes, technologies, and security and privacy challenges," *IEEE/CAA J. Autom. Sinica*, vol. 8, no. 2, pp. 273–302, Feb. 2021.
- [43] A. Pagano, D. Croce, I. Tinnirello, and G. Vitale, "A survey on LoRa for smart agriculture: Current trends and future perspectives," *IEEE Internet Things J.*, vol. 10, no. 4, pp. 3664–3679, Feb. 2023.
- [44] D. Loukatos, I. Manolopoulos, E.-S. Arvaniti, K. G. Arvanitis, and N. A. Sigrimis, "Experimental testbed for monitoring the energy requirements of LPWAN equipped sensor nodes," *IFAC-PapersOnLine*, vol. 51, no. 17, pp. 309–313, 2018.
- [45] A. Al-Fuqaha, M. Guizani, M. Mohammadi, M. Aledhari, and M. Ayyash, "Internet of Things: A survey on enabling technologies, protocols, and applications," *IEEE Commun. Surveys Tuts.*, vol. 17, no. 4, pp. 2347–2376, 4th Quart., 2015.
- [46] S. Deb, P. K. Bhowmik, and A. Paul, "Remote detection of illegal electricity usage employing smart energy meter—A current based technique," in *Proc. ISGT-India*, Dec. 2011, pp. 391–395, doi: [10.1109/ISGT-India.2011.6145348](https://doi.org/10.1109/ISGT-India.2011.6145348).
- [47] M. Burhan, R. Rehman, B. Khan, and B.-S. Kim, "IoT elements, layered architectures and security issues: A comprehensive survey," *Sensors*, vol. 18, no. 9, p. 2796, Aug. 2018.
- [48] N. Nasser, L. Karim, A. Ali, M. Anan, and N. Khelifi, "Routing in the Internet of Things," in *Proc. IEEE Global Commun. Conf. (GLOBECOM)*, Dec. 2017, pp. 1–6.
- [49] P. Uros, J. J. Mohorko, K. Benkič, and Ž. F. Čučej, "Single-hop vs. multi-hop—Energy efficiency analysis in wireless sensor networks," in *Proc. 18th Telecommun. Forum*, 2010, pp. 471–474.
- [50] M. Sabet and H. Najj, "A decentralized energy-efficient hierarchical cluster-based routing algorithm for WSNs," *AEU-Int. J. Electron. Commun.*, vol. 69, no. 5, pp. 790–799, 2015.
- [51] Z. Fei, B. Li, S. Yang, C. Xing, H. Chen, and L. Hanzo, "A survey of multi-objective optimization in wireless sensor networks: Metrics, algorithms, and open problems," *IEEE Commun. Surveys Tuts.*, vol. 19, no. 1, pp. 550–586, 1st Quart., 2017.
- [52] E. Effah and O. Thiare, "Survey: Faults, fault detection and fault tolerance techniques in wireless sensor networks," *Int. J. Comput. Sci. Inf. Secur.*, vol. 16, no. 10, pp. 1–14, Oct. 2018.
- [53] A. Chalimov. (Nov. 1, 2021). *IoT in Agriculture: 8 Technology Use Cases for Smart Farming (And Challenges to Consider)*. [Online]. Available: <https://easternpeak.com/blog/iot-in-agriculture-technology-use-cases-for-smart-farming-and-challenges-to-consider/>
- [54] F. Thiam, M. Mbaye, and A. M. Wyglinski, "Generic reliability analysis model of IoT : Agriculture use case," in *Proc. IEEE 93rd Veh. Technol. Conf. (VTC-Spring)*, Apr. 2021, pp. 1–5, doi: [10.1109/VTC2021-Spring51267.2021.9448791](https://doi.org/10.1109/VTC2021-Spring51267.2021.9448791).
- [55] F. Thiam, E. Effah, A. Wyglinski, O. Thiare, and M. Mbaye, "Proof-of-concept custom flexibility agricultural IoT-based test-bed," *IEEE Access*, pp. 1–14, Feb. 2021.
- [56] B. Elbhiri, R. Saadane, S. El fldhi, and D. Aboutajdine, "Developed distributed energy-efficient clustering (DDEEC) for heterogeneous wireless sensor networks," in *Proc. 5th Int. Symp. IV Commun. Mobile Netw.*, Sep. 2010, pp. 1–4.
- [57] P. Saini and Ajay. K. Sharma, "E-DEEC—Enhanced distributed energy efficient clustering scheme for heterogeneous WSN," in *Proc. 1st Int. Conf. Parallel, Distrib. Grid Comput. (PDGC)*, Oct. 2010, pp. 205–210.
- [58] S. A. Tanveer, N. M. S. Sree, B. Bhavana, and D. H. Varsha, "Smart agriculture system using IoT," in *Proc. IEEE World Conf. Appl. Intell. Comput. (AIC)*, Jun. 2022, pp. 482–486.
- [59] O. M. Olabanji and K. Mpofo, "Comparison of weighted decision matrix, and analytical hierarchy process for CAD design of reconfigurable assembly fixture," *Proc. CIRP*, vol. 23, pp. 264–269, Jan. 2014.



EMMANUEL EFFAH (Member, IEEE) received the B.Sc. degree in electrical and electronic engineering from the University of Mines and Technology (UMaT), Ghana, the M.Sc. degree in information technology from the Open University of Malaysia, and the Ph.D. degree in computer science from Gaston Berger University, Senegal. He is currently a Lecturer with the Department of Computer Science and Engineering, UMaT. Currently, he is the principal investigator (PI) of the World Bank-RSIF/JIRA-Funded Agri-IoT Tech Project (RSIF/JIRA/004) and the Senior Personnel of the NSF-Funded DISES Project (2307870). He has authored many research papers published in reputable journals and conference proceedings and has participated in several international research projects. His research interests include wireless sensor networks (WSNs), the Agricultural-Internet of Things (Agri-IoT), the IoT, smart systems design technology, and machine learning.



OUSMANE THIARE (Member, IEEE) received the Ph.D. degree in computer science from the University of Cergy-Pontoise, Paris, France. He is currently the Vice-Chancellor of Gaston Berger University, Saint Louis, Senegal. He has published research papers in national and international journals, conference proceedings, and chapters of books. His research interests include the Internet of Things (IoT), wireless sensor networks, mobile ad-hoc networks, parallel and distributed systems, peer-to-peer systems, routing, and data replication and grid and cloud computing.



ALEXANDER M. WYGLINSKI (Senior Member, IEEE) received the B.Eng. degree in electrical engineering from McGill University, Montreal, Canada, in 1999, the M.Sc. (Eng.) degree in electrical engineering from Queen's University, Kingston, Canada, in 2000, and the Ph.D. degree in electrical engineering from McGill University, in 2005. He is currently a Professor in electrical and computer engineering with Worcester Polytechnic Institute (WPI), Worcester, MA, USA, where he has been the Director of the Wireless Innovation Laboratory, since 2007, and was the President of the IEEE Vehicular Technology Society (2018–2019). His current research interests include wireless communications, cognitive radio, machine learning for wireless systems, software defined radio prototyping, connected and autonomous vehicles, dynamic spectrum sensing, characterization, and access.

• • •