

Received 2 January 2024, accepted 21 January 2024, date of publication 26 January 2024, date of current version 5 February 2024.

Digital Object Identifier 10.1109/ACCESS.2024.3358843

## RESEARCH ARTICLE

# Integration of Bridge Health Monitoring System With Augmented Reality Application Developed Using 3D Game Engine—Case Study

MUHAMMAD FAWAD<sup>1,3</sup>, MAREK SALAMAK<sup>1</sup>, MUHAMMAD USMAN HANIF<sup>2</sup>, KÁLMÁN KORIS<sup>3</sup>, MUHAMMAD AHSAN<sup>4</sup>, HADIYA RAHMAN<sup>5</sup>, MICHAEL GERGES<sup>6</sup>, AND MOSTAFA MOHAMED SALAH<sup>7</sup>, (Member, IEEE)

<sup>1</sup>Department of Mechanics and Bridges, Silesian University of Technology, 44-100 Gliwice, Poland

<sup>2</sup>Department of Architectural Engineering, Korea National University of Transportation (KNUT), Chungju 27469, South Korea

<sup>3</sup>Department of Structural Engineering, Budapest University of Technology and Economics, 1111 Budapest, Hungary

<sup>4</sup>Department of Measurements and Control Systems, Silesian University of Technology, 44-100 Gliwice, Poland

<sup>5</sup>Faculty of Management, Wrocław University of Science and Technology, 50-370 Wrocław, Poland

<sup>6</sup>Faculty of Science and Engineering, University of Wolverhampton, WV1 1LY Wolverhampton, U.K.

<sup>7</sup>Electrical Engineering Department, Future University in Egypt, Cairo 11835, Egypt

Corresponding authors: Muhammad Fawad (muhammad.fawad@polsl.pl) and Mostafa Mohamed Salah (mostafa.abdulkhalek@fue.edu.eg)

**ABSTRACT** In recent times, digital transformations and Industry 4.0 have revolutionized real-time bridge monitoring and its inspection. The use of smart Structural Health Monitoring (SHM) techniques is becoming powerful with the competencies of Building Information Modeling (BIM) tools, Artificial Intelligence (AI), Internet of Things (IoT), and Virtual/Augmented (VR/AR) technologies. However, the lack of interconnectivity between these tools limits their functionality. This research has addressed this problem by developing an integrated framework to assess serviceability and implement a smart SHM for a newly constructed extradosed bridge. Using Finite Element Analysis (FEA), the study proposes an integrated SHM system that utilizes various IoT sensors, including Wired Strain Gauges (WSG), Liquid Levelling Sensors (LLS), MEMS accelerometers, and a Weather Monitoring Station (WMS) to monitor concrete deformations, vertical displacements, structural vibrations, and weather conditions. BIM tool is used to develop the virtual replica of the proposed SHM system which is then used in the 3D Game Engine (GE) to develop an AR application. This application is then successfully deployed and tested in the AR headset (HoloLens) where its capabilities for onsite bridge health monitoring are discovered. This approach overcomes the limitations of HoloLens devices by providing real-time access to SHM data through a web platform, enabling on-site or remote AR-based bridge health monitoring. Conclusively, this paper emphasizes the numerical modeling of bridges for the design of a health monitoring system, that highlights the importance of robust SHM techniques in assessing bridge conditions. Moreover, it introduces a novel approach for smart bridge inspection and onsite visualization of structural defects in an AR environment.

**INDEX TERMS** Bridges, finite element modelling, SHM, IoT sensors, AR, HoloLens.

## I. INTRODUCTION

Condition assessment of new and existing bridges requires valuable and reliable information about their serviceability

The associate editor coordinating the review of this manuscript and approving it for publication was Shaohua Wan.

and performance parameters [1]. The increasing development of bridge construction and strict compliance with their safety is necessitating the use of sensors for proper monitoring of bridges which is based on the development of a Structural Health Monitoring (SHM) system [2]. Bridge condition monitoring is always in need of reliable techniques that

can provide the basis for the effective operability and safe usage of the bridge throughout its life, among them the most adopted technique is the numerical modeling of the bridge [3]. Therefore, accurate analysis results of numerical models are of prime importance for the bridge monitoring system [4]. These numerical analysis results are sometimes validated by load tests which have focused on the improvements in analysis and design procedures, evaluation of the bridge design code provisions, and tracking the in-service behavior of bridges [5], [6]. The effective utilization of Finite Element Analysis (FEA) results is based on the analysis type, structural design procedures, and Finite Element (FE) model updating of the bridge structure [7]. After the validation, critical values of the resulting parameters are pointed out for the identification of the locations and types of sensors [8]. In this regard, linear static and 3D nonlinear analyses are commonly carried out to locate the position of sensors [9], [10].

SHM of bridges has been the interest of many researchers, thus, state-of-the-art research is available on this topic [11], [12]. The proposal of the SHM system considers FEA results and outcomes of load tests because experimental studies in the field and analytical studies using the FEA framework provide the decision-making for a proper SHM system for the bridge [13], [14]. The success of this system is based on the sensors used for the measurement of bridge health parameters. For this purpose, the most suitable and field-oriented sensors are usually preferred for the installation.

Monitoring of deformations in Reinforced Concrete (RC) structural elements is of great importance and is considered the basic parameter that has to be recorded by the SHM system of bridges, therefore, robust and heavy-duty devices like vibrating strain gauges are considered suitable to measure the strains in the concrete [15], [16]. In addition to this, the measurement of vertical displacement is also an important parameter for the health evaluation of bridges and it is convenient to measure it directly on long-span bridges. Therefore, Liquid Levelling Sensors (LLS) are considered the most suitable and promising devices for this kind of measurement [17], which can overcome the problem of inclination angles and provide the most accurate results [18]. Moreover, measurement of linear deflection is also important as many of the sensors do not satisfy the field measurement criteria, so, for this purpose, Linear Variable Differential Transformers (LVDT) are the best-suited devices that can be reliable for field measurement of linear displacement for a longer period of time [19]. Vibration monitoring and measurement of dynamic parameters is also an integral part of the bridge SHM system for which MEMS Accelerometers (MA) offer the best services quantitatively. In addition to vibration monitoring, they can also monitor the forces in the cables and evaluate the structural integrity of extradosed bridges [20], [21]. In addition to the mentioned sensors, the SHM system is incomplete without the weather condition

monitoring station. These kinds of stations are usually established at the center of the bridge with certain temperature and humidity measurement devices, wind speed and wind direction monitoring sensors, and atmospheric pressure measuring devices.

Research works have integrated the SHM systems with BIM technology [22], [23], [24] to develop the BIM-based monitoring system where the Internet of Things (IoT) tools facilitated the data integration processes [25], [26]. This integrated system majorly focused the information management and fault detection using real-time sensor data. The major portion of these works revolved around data management and integration in the BIM models, [27], [28], [29], thus lacking the AR-based immersive solutions that are required to visualize SHM data. Similarly, some other research works [30], [31] proposed only the 3D visualization capabilities of AR at the industrial scale without exploring the automation of health monitoring parameters in the AR environment. Moreover, [32] reviewed the proposals for data management/integration and visualization of real-time SHM data using AR but the practical implications of these proposals were not found. Instead, they were mentioned as the future research directions - without any practical implementation. Further, a quality work [33], [34] proposed AR-based automated damage identification methodologies that used AI models to detect and classify different damages and visualize the SHM data using integrative frameworks, and metadata in AR. However, it just focused on the length, area, and perimeter of the structural objects whereas in bridge structures more complex objects are considered. Additionally, [35] used AR devices to detect potential problems in the target structures using thermal images. [36] studied the time delay of bridge Digital Twins (DT) services and proposed an Artificial Intelligence of Things (AIoT)-based DT communication framework that can support smart bridge operation and maintenance. These works too missed the immersive nature of detected damages. So, all the mentioned research works lack either the automation part or the visualization of the detected damages in an AR-based immersive environment, where the authors found a potential research gap. Moreover, none of these research works were seen to target the bridge monitoring system. To further explore the gaps in this domain, [37] carried out a detailed review of the implementation of AR technology in bridge monitoring. This review also lacked a unified BIM/AR-based immersive bridge SHM system that can not only perform real-time bridge health monitoring but can also visualize and integrate the SHM data remotely or onsite. These research gaps fueled the motivation of the authors to develop a unified AR application that can perform the said functions and overcome the heightened research gaps.

The state-of-the-art of this research lies in the integration of BIM technology, SHM, and AR technology, where the 3D game engine is used to develop an AR application, that can be used to automatically integrate the BIM-based virtual SHM

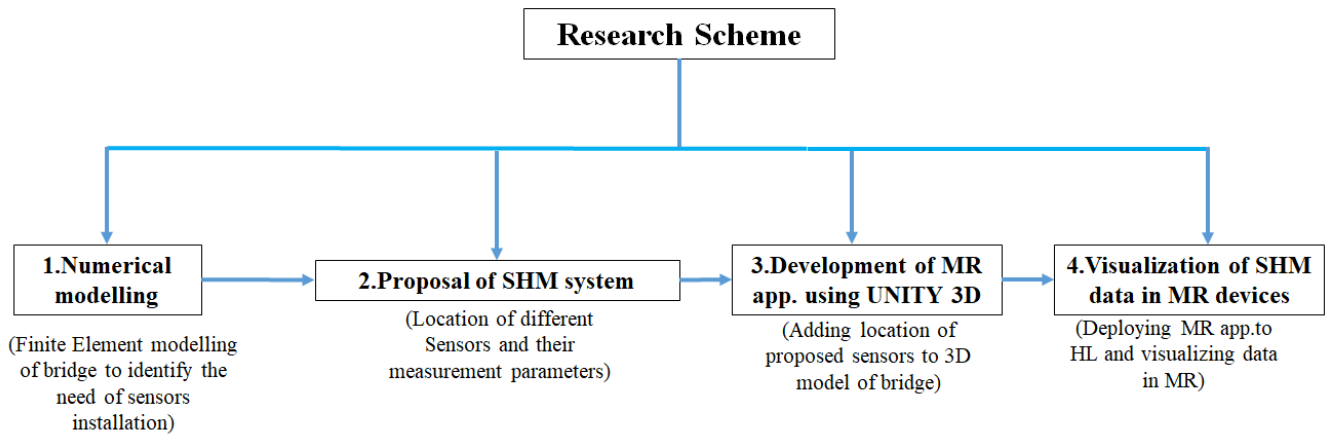

FIGURE 1. Schematic layout of research work.

system with the real system to perform real-time bridge health monitoring in an AR environment.

## II. OBJECTIVES OF THE RESEARCH AND USED METHODOLOGY

This research focuses on the integration of bridge SHM systems with AR using the applications of BIM technology. For this purpose, numerical analysis of a real-life bridge is performed using the FE analysis technique, and the SHM system is proposed based on the identified critical zones of the bridge. Further, the BIM technology is used to develop the AR-based SHM system of the bridge. This smart system is developed in 3D GE (UNITY 3D), which is directly linked with the IoT-based web platform of the real SHM system. In this way, the major objective of this research is achieved by developing an integrated framework that helps in automating the SHM system and visualizing its data remotely or onsite. All the steps followed in this research work are enlisted in the schematic diagram shown in Figure 1.

## III. EXPERIMENTAL WORK TO DESIGN A BRIDGE MONITORING SYSTEM

### A. DESCRIPTION OF THE BRIDGE STRUCTURE

For this research, a case study of an extradosed bridge structure, located along the National Highway 75 in Poland, is considered. The bridge consists of four spans having continuous prestressed decks made of C60/75 concrete. The lengths of the external two spans are 100m whereas the central two spans are 200.0 m long. The original design of the bridge was carried out following the Load Model (LM)-1 according to the Euro Code (EC)-1 standard [38] (having the adaptation coefficients  $\alpha = 1.00$ ) and for class A according to the PN 85/S standard [39]. The overall width of the structure is 17.68 m having a two-directional roadway (8.60 m wider between curbs). In addition, there is a 4.0 m wider pedestrian and bicycle route supplemented with a balustrade.

The box girder section of the structure has a constant height of 4 m. The bottom slab of the box section has a width

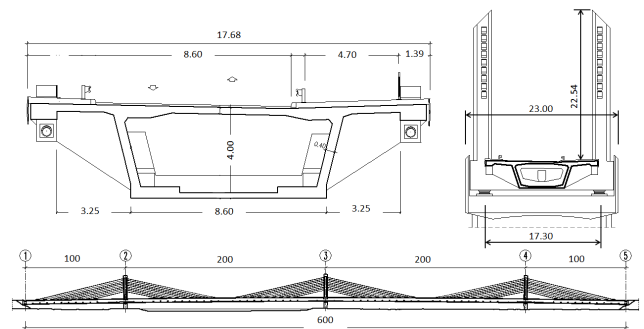

FIGURE 2. Bridge cross-section and spans layout.

of 8.60 m which increases to 10.10 m at the top slab. The diagonal webs have a width of 0.40 m in the mid-zone of the spans and 0.60 m in the support zone. The webs are connected with the upper and lower slabs having a thickness of 0.30 and 0.25 m, respectively, in the middle zone of the spans. The lower slab has a thickness of 0.70 m in the supporting zone. There are 22.70 m high pylons (measured against the grade line) supported on the intermediate supports having a cross-section of 2.70 × 3.50 m, fixed in the girder. The layout of the bridge with a cross-section is shown in Figure 2.

### B. MONITORING SYSTEM DESIGN USING NUMERICAL MODELING TECHNIQUE

There are several techniques for the design of a bridge monitoring system but numerical modeling is the most robust and adopted one to study the behavior of a bridge and identify the associated damages which in turn identify the need and location of monitoring devices. The FEA gives complete details of the bridge's current state of materials, the effects of loading, and environmental conditions on the bridge's daily use. It also helps to identify the monitoring points for these parameters. Thus static linear analysis (FEA) of the bridge is carried out in this research to calculate and

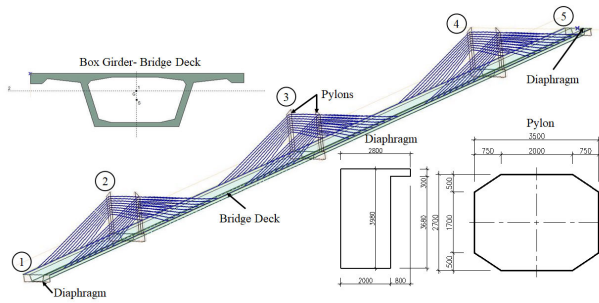

FIGURE 3. FE model of the bridge.

analyze the internal forces and span displacement. Further, cracking of the bridge is also observed. The values of the bending moments are observed to check for the moment capacity of the bridge. Moreover, the deflected shape of the cables is considered to evaluate their movements for the identification of monitoring points. In this numerical analysis, only those parameters (stresses, strains, internal forces, crack widths, temperature, and humidity variations) are observed which have a direct impact on the bridge health and whose monitoring is critical for bridge damage identification. The developed numerical model with the adopted geometry and its cross-section is shown in Figure 3.

### C. DISCUSSION OF THE OUTCOMES OF NUMERICAL ANALYSIS

In this research, the maximum bending moments in the bridge spans and cross sections are calculated and are shown in Figure 4. These results are then compared to the EC limits [38], to evaluate whether the bridge has sufficient moment capacity or not. Due to low values of stresses in the cross-sections, axial forces in the girder were omitted from the analysis parameters. The findings of the linear analysis show that the structure has a somewhat higher flexural stiffness.

The shear force resulting from the applied load is substantially below the resistance of the reinforcement, which gives enough shear resistance to the structure. Although the reinforcement can withstand greater stresses, the surface stresses in the tension zones are comparable to internal forces and found to be reasonable. Additionally, the ranges of all stress controls are also observed to be satisfactory.

In the case of the cables, as shown in Figure 4, it is considered that the elastic stay cables are completely flexible and can only withstand tensile forces. In the analysis, only the self-weight of the cables is considered so the deflection due to their own weight is analyzed, which shows that inclined stay cables sagged into a catenary shape. The sag of the cables is observed more in the first three cables of each section which shows that these cables need monitoring of cable's tension stiffness, which varies with the amount of sag.

In order to monitor the cracking of the concrete in the box girder and pylons, the calculated reinforcement with minimum concrete cover is used in this analysis. The cracking

profile of the whole box-girder and pylons, as shown in Figure 4, does not show any significant cracks that are affecting the bridge load-bearing capacity. The maximum crack width (0.60 mm) is observed at the support of the box girder, whereas the crack width at the web of the spans is found to be 0.20 mm which is exactly the same as observed in the visual inspection. The stress concentrations at the mid-span and closer to cable connections are quite significant and are considered for long-term monitoring.

### IV. PROPOSAL OF SHM SYSTEM

Considering the need for proper monitoring of the bridge, the SHM system is proposed. There are several ways of bridge sensor placement mainly including Information from the previous studies, field conditions, and structural requirements supplemented with the experience of bridge inspectors, results of FEA, based on the maximization of the Fisher Information Matrix (FIM), based on the properties of the covariance matrix coefficients, and using energetic approaches. In the case of the subject bridge, the most adopted methods are used for the proposal of the SHM system, which includes the results of FEA analysis and the expert opinions of system designers. The system will provide the onsite monitoring of the technical condition of the structural elements at selected measurement points of the bridge. Considering the functional use of the bridge, continuous assessment of rheological properties, the behavior of the bridge under the applied loads, and monitoring of the suspension system and bridge spans are important which necessitates the need for the proper SHM system. The proposed system will perform the monitoring of deformation measurement, synchronous dynamic measurements (Dynamic deflection and accelerations), structural response measurement under the operational loads, and monitoring of temperature, humidity, and wind effects on the structure.

The SHM system first includes the installation of vibrating wire strain gauges (WSG) to measure the deformation in the RC pylons and slabs of the box girder. The selection of these sensors is considered after analyzing the strain profile of the bridge along the bridge deck and in the pylons. These sensors are made up of stainless-steel tubes having flanges at both ends. Inside the tube, between the flanges, is the vibrating wire being in the tension between the ends of the tube which are fixed in the concrete. For the measurement of the strain inside the concrete, the wire is plucked in such a way that it starts to vibrate inside the tube. The frequency of this vibrating wire is dependent on the strain in the concrete. The change of the vibrating frequency directly reads the strain or stress in the concrete which accounts for the deformation of RC members. In the case of the subject bridge the most critical parts (supports, pylons, and mid-span) are marked for the installation of strain gauges so, 16 sensors are proposed to be installed along the bridge. The layout of these sensors is shown in Figure 5.

The next device planned for this system is the Liquid Levelling Sensor (LLS) for the measurement of vertical

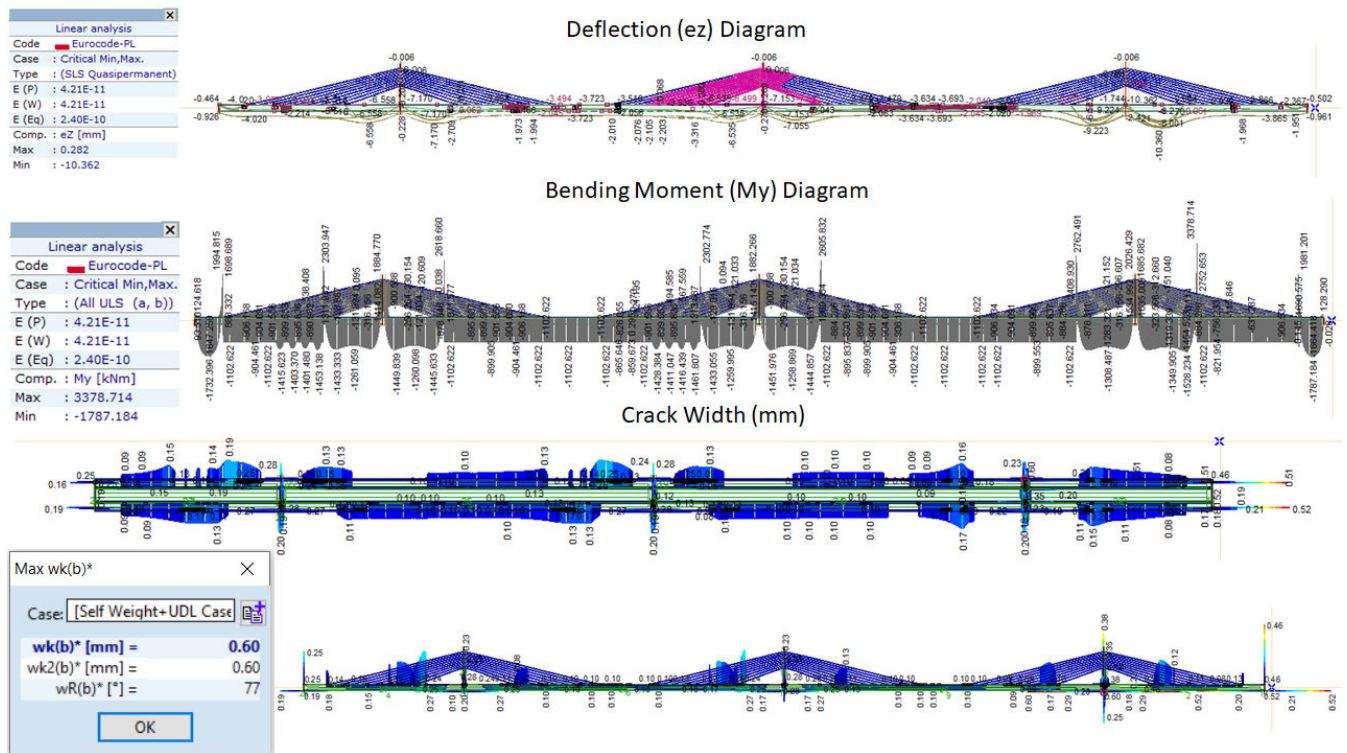

FIGURE 4. FE analysis results with the indicated crack width.

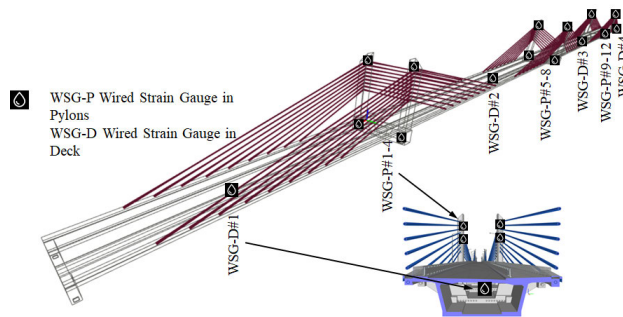

FIGURE 5. Location of strain gauges.

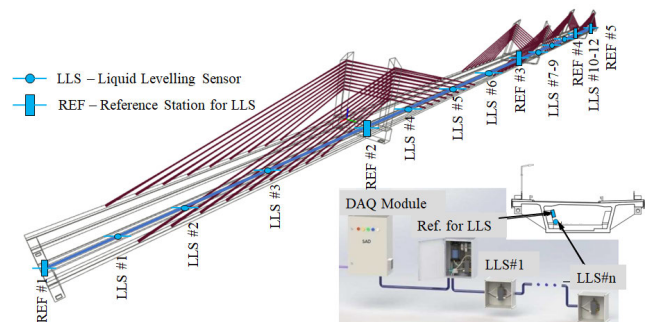

FIGURE 6. Location of LLS.

displacement. These sensors are connected in series with the reference station forming a hydrostatic system for measuring the changes in displacement relative to the reference point. The reference sensor is set outside the measurement zone staying fixed during the measurement time and is a reference for the other measurement sensors in the circuit. System components are connected by a cable filled with liquid and set the air pressure in a line. The movement of the sensor causes a pressure difference, which is measured by the transducer placed in the sensor. With this scheme five sets (3 sensors with an additional reference sensor) are planned to measure the vertical displacement in each span of the bridge. The layout of these sensors is shown in Figure 6.

For the measurement of linear displacement, LVDTs are recommended to be installed in each span of the bridge. As they work on the principle of a transformer, they measure the displacement by linking the signal values with the position. With every fluctuation of the signal, it measures the displacements. These sensors are further used to inspect the rheological properties of each span of the bridge. These sensors are directly attached to the surface of the box girder at the expansion joints and measure the deformations directly. So, a total of 5 sensors are recommended to be installed at each of the expansion joints. The layout of these sensors is shown in Figure 7.

To monitor the effects of external loads on the structure, especially the dynamic effects of moving and wind loads,

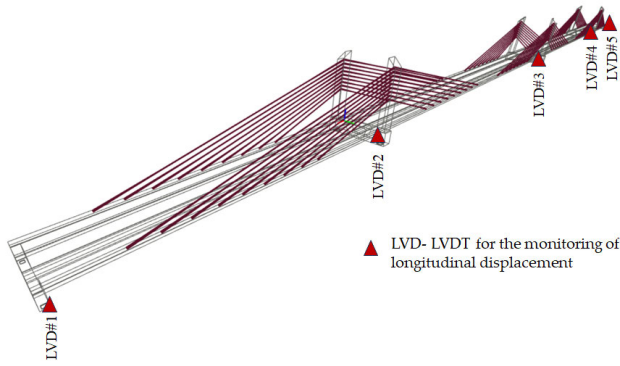

FIGURE 7. Location of LVDTs.

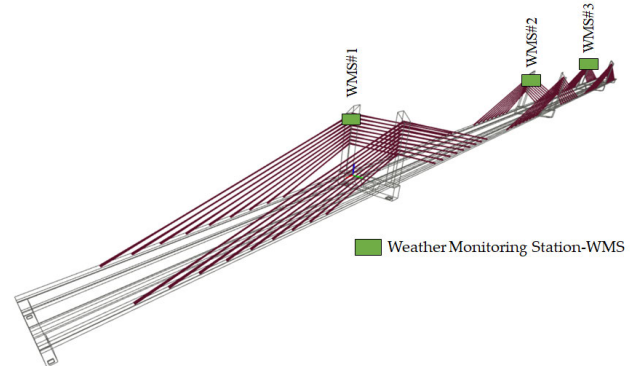

FIGURE 9. Location of Mateo station.

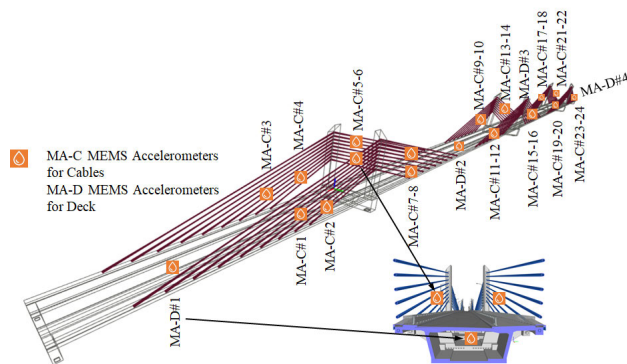

FIGURE 8. Location of accelerometers.

MEMS accelerometers are proposed to be installed. These sensors are based on the principle of compression, where the compressive loads produce a charge in the sensors. This charge produces vibrations of a certain frequency which are measured directly from the applied force using Newton’s Second Law of Motion. Measurement of vertical acceleration at the center of each span will be carried out using these sensors, therefore, 4 sensors are recommended to be installed on the whole bridge. Further, the results of the FE analysis show the critical deflection of the first three cables in each set, thus, 2 sensors at the first and third cables will monitor the vibrations and other dynamic parameters along the cables. The measurement of the force will be carried out by analyzing the vibration frequency along the cable; therefore 2 directional measurements will be carried out using these sensors. 2 sensors in each set of cables are planned to be installed. In this way, a total of 24 sensors are proposed. The layout of these sensors is shown in Figure 8.

In addition to the measurement of the above-mentioned parameters, monitoring of climatic parameters is also important for bridge health. For this purpose, the SHM system of the bridge is also provided with the monitoring of wind speed and its direction and measurement of temperature and humidity along the facility. For these measurements, sensors measuring wind speed, wind direction, temperature,

and humidity measurement devices are recommended to be installed at each set of pylons (Fig. 10). These devices will be installed as a weather monitoring control station provided with the multichannel data logger having a built-in atmospheric pressure sensor. This weather monitoring control station is planned to be installed at the central pylon of the bridge. This way surveillance of the whole bridge can be carried out efficiently. The layout of these sensors is shown in Figure 9.

To achieve the research objectives, wireless sensors integrated with the IoT web platform were needed. For this purpose, three wireless sensors (1xWSG, 1xWMS, and 1xMA) were selected as the representative of the proposed SHM. These sensors were then used to develop the AR-based SHM using the applications of BIM and IoT tools. These tools facilitated the online data integration and helped in the immersive bridge health monitoring using the real-time monitoring of the health parameters. The results of the measured parameters are automatically updated and visualized in the graphical format as shown in Figure 10.

**V. DEVELOPMENT OF THE AR-BASED SHM SYSTEM USING A CUSTOMIZED AR APPLICATION**

DT-based automated SHM systems are currently trending in bridge monitoring because of their on-field applications but this research tried to develop the AR-based SHM system which can enhance the capabilities of a traditional SHM system using the applications of AR. Currently, AR applications in the construction industry are only used for machine control on construction sites, concrete pouring, reinforcement detection, onsite clash detection, and worker’s field safety [40], [41], [42]. So far, very limited research is available that tries to implement this technology in bridge monitoring, thus, this research offered a novelty by developing an immersive AR-based SHM system.

The developed immersive SHM system includes the wireless IoT sensors which integrate real-time sensor data from the installed sensor network and process it through a web platform with real-time analysis AI algorithms. The processing of SHM data is not in the scope of this research

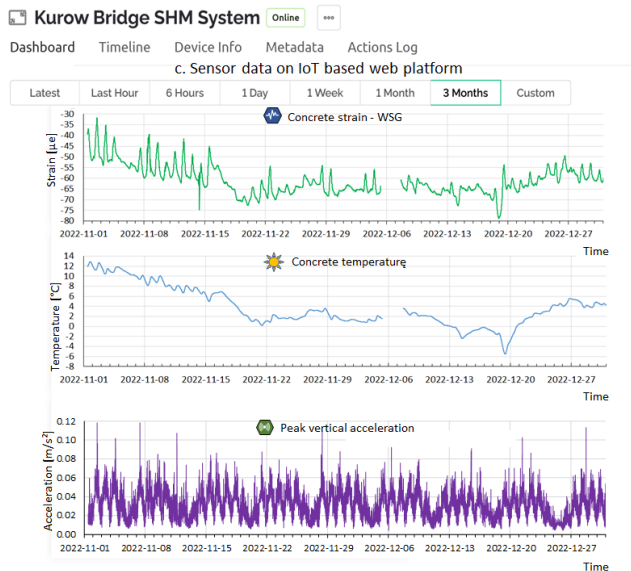

FIGURE 10. The IoT-based web platform of the bridge SHM system.

thus, no particular attention is given to data processing algorithms. The integration of SHM data with AR using AR headsets creates a seamless real-virtual blend. Holographic overlays highlight critical areas and gesture controls enable online data management. This way it helps to manage the technical condition of the bridge with real-time alerts, remote/onsite monitoring, cloud integration, data visualization, system calibration, and maintenance procedures to ensure the system's accuracy, reliability, and functionality while offering an advanced solution for monitoring of bridge health in real-time.

To achieve these goals, the VR model of the bridge is created from scratch using the BIM tool (Revit) [43]. After uploading the VR model to the AR device, it can be implemented in the AR where the real coordinates of the bridge are embedded as a QR code. Scanning this code from the exact ground location projects the model in AR [44]. After the projection of the BIM model in the AR environment, several functions like real-time damage detection, clash detection, ground reality checks, construction quality control, and SHM data management can be performed. In this research, AR implementation is linked with the IoT-based web platform where the real-time data of bridge sensors is stored, which is then linked with the AR model by developing the virtual replicas of the sensors on the BIM model (embedded with the web address of the IoT platform). In this way bridge sensors can be developed virtually on the BIM model and sensor data can be managed and visualized using the AR devices.

#### A. LIMITATION OF AR DEVICES (HOLOLENS) TO ACCESS IOT WEB PORTAL

The authors performed several field tests for bridge health monitoring using AR device (HoloLens). During these field

experiments, some results weren't successfully achieved which helped to identify the limitations of HoloLens. When the BIM model supplemented with virtual sensors was uploaded to HoloLens and implemented in AR, it was encountered that the virtual sensors (with the embedded URL of the SHM platform) were not functional in the AR environment. Several attempts were made to activate the sensors in the AR environment, but no success was achieved. To address this limitation, some literature was reviewed which proposed a solution to this problem using UNITY 3D [45], [46]. UNITY 3D has the capabilities of AR application development which can address the limitations of AR devices.

#### B. DEVELOPMENT OF AR APPLICATION (APP) FOR THE AR-BASED SHM SYSTEM

The basic objective of this app development was to overcome the limitations of AR devices (HoloLens) by developing a novel way of linking the IoT platform of the bridge SHM system with its AR model. For this purpose, the BIM model of the bridge was used as a source file in a 3D game engine (UNITY 3D). In order to use this model in the AR, the Mixed Reality Tool Kit (MRKT) is integrated and configured with the project. This configuration helps to develop the Universal Window Platform (UPW) which defines the build settings of the app and links it with VR/AR platforms, Android, and WebGL platforms. In this research, UPW is developed for HoloLens, so the target device is set to HoloLens with ARM 64-bit Architecture, which defines the architectural configuration of the project. After developing the build settings, SHM sensors are virtually developed using Canvas meshes. Canvas helped to generate these sensors as a clickable button in order to integrate them with real sensors of the bridge.

After adding sensors to the app virtually, they are integrated with the IoT platform of the SHM system, for which a C-sharp script is developed in Visual Studio (VS). This script can link the sensor to any of the web platforms. The script is kept generic by adding multiple web addresses to each sensor. After developing the script in VS, it is attached to the UNITY so that it can be further linked to each sensor. This way each virtual sensors are linked with the real sensor's data. To run this app, play mode is switched on, and clicking each sensor opens the SHM data in the web browser. A visual interface of these steps and the developed app in the UNITY environment is shown in Figure 11.

#### C. DEPLOYMENT OF AR APP TO HOLOLENS

After successful testing of the developed app in UNITY, it is then deployed to HoloLens. Deployment of the developed app involves setting up HoloLens settings and pairing the app with the target HoloLens device. For this purpose, firstly, build settings are set to the "build" option in UNITY to develop a .sln (Visual Studio file) file that can open the project in VS. After opening the project in VS, the first thing is to pair

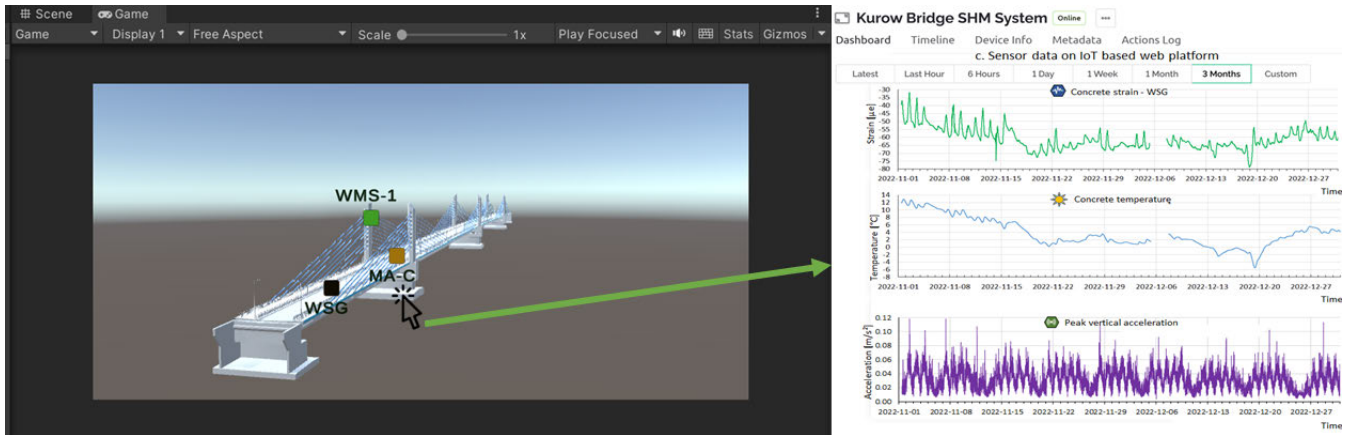

FIGURE 11. App development in UNITY 3D and its linkage with the IoT platform.

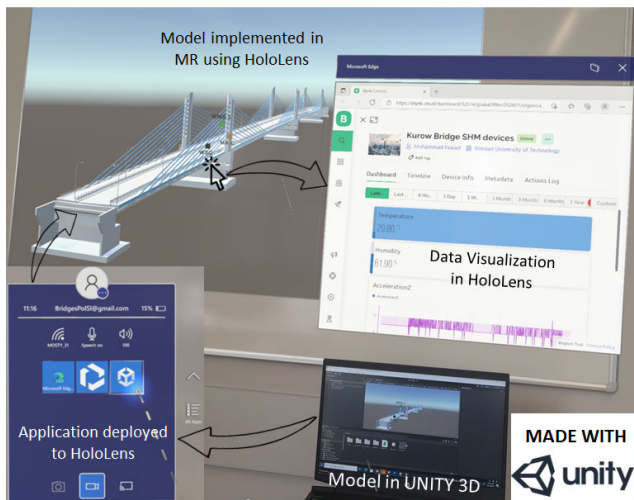

FIGURE 12. Visualization of SHM data in HoloLens.

the device with the HoloLens over the wifi network. It can be done by turning on the developer mode of HoloLens and retrieving a code that after adding to the VS project connects UNITY with the HoloLens. After that, the IP address of the HoloLens is added to the VS project for debugging. This started the deployment of the app to HoloLens and after successful deployment, the app icon appeared in the main menu as shown in Figure 12.

**D. VISUALIZATION OF SHM RESULTS USING THE DEVELOPED APP**

After the deployment of the app in the UNITY, it was opened and tested at the lab scale. All the SHM devices were found to be at the exact locations of the actual sensors. Clicking the sensor opens the IoT platform where real-time data is continuously monitored and stored. This data can be visualized over a certain period (1 hr., 6 hr., 1 day, 1 week, and 3 months) (Figure 12). Data can also be stored in HoloLens as a .CSV file which can further be transferred to any workstation. This way visualization of SHM data can

be performed onsite or remotely and data can be transferred to the project team over the Internet. The schematic layout of this whole process is shown in Figure 12.

**VI. EVALUATION OF THE PERFORMANCE AND RELIABILITY OF THE AR-BASED SHM SYSTEM IN REAL-WORLD BRIDGE MONITORING**

The success of the developed AR-based SHM system requires long-term performance monitoring and evaluation in real-world scenarios. The successful implementation of this system requires several key factors, i.e. Long-term stability, periodic calibration of system accuracy and precision, adaptability, and scalability, maintenance of sensors network and IoT platform, user feedback and industrial surveys, data integration, and regular updating of the AR- application. Once the system is installed on a bridge, the in-depth analysis of these aspects through the bridge inspection activities, data processing, and regular system modification will offer the real benefits of this promising system in bridge monitoring.

**VII. COST AND BENEFIT ANALYSIS OF TRADITIONAL SHM SYSTEM WITH THE IMMERSIVE SHM SYSTEM**

This research is primarily “applied,” in nature aimed at benefiting the stakeholders of the bridge industry. To further elaborate on the benefits of the proposed AR-based SHM system over the traditional system a thorough cost-benefit analysis comparing both the bridge monitoring methods is presented in (Table 1).

This table explains a detailed comparison of the costs and benefits associated with the AR’s implementation in bridge monitoring. This comparison provides valuable information for decision-making in the field of infrastructure management. Additionally, it is essential to consider the existing condition of the bridge, its design parameters, specific safety requirements, and monitoring goals when evaluating the system requirements and making decisions based on the presented analysis.



**TABLE 1. Cost-benefit analysis of AR-based SHM system and traditional system.**

Cost to benefits	AR-based SHM System	Traditional SHM system
Initial cost	High initial cost for IoT sensors, software, hardware, and system integration	Comparatively low initial cost of conventional sensors and other equipment
Software/Application development	One-time system/application development cost. No/limited wiring and electricity cost.	No direct costs for system development but wiring and electricity cost are relatively high
Specialized personal/Staff Training	Skilled staff/training equipment required for training of staff on AR/HOT technologies	No requirement of modern technologies so minimal training costs
Maintenance costs	Minimal costs for system updates as automated systems updates software, automated sensor calibration and technical support	Routine maintenance costs/equipment parts incur are high
System capabilities	Real-time monitoring, immersive visualization	Lacks immersive visualization/real-time monitoring
Monitoring options	Onsite and offsite monitoring capabilities	Only offsite monitoring options
System efficiency and accuracy	Highly efficient data collection and processing capabilities with higher accuracy	Slower data collection with relatively low accuracy
Worker's safety	Lesser/minimal physical interaction with onsite visualization capabilities makes it potentially safer	No visualization of potential damages increases safety risks and associated costs
Long-term financial benefits	Automated system with minimal manpower and early damage detection saves money	Periodic maintenance and auxiliary costs increases the long-terms costs
Risk factors involved	Potential risks connected to technological reliability and system failures	Major risks are associated with the safety, electricity usage and data reliability
Total Cost	System costs include high initial costs, additional devices and equipment, staff training costs but lower maintenance/repair costs.	Lower initial costs but higher maintenance/repair costs
Total Benefit	Higher safety, accuracy, and automated monitoring with enhanced safety and potential time savings	Simplified system but more time consuming and compromised safety

**VIII. PRACTICAL APPLICATIONS OF THE RESEARCH FINDINGS**

The use of BIM technology is evolving in bridge management and monitoring systems. Typically, it helps the management of SHM data, interoperability of different software platforms, management of construction processes, and coordination purposes [47] but the applications of BIM technology are still unexplored in the implementation of AR/VR.

This research explains the demonstrative nature of an AR-based SHM system for a bridge. The scalability and generalizability of this technique was a challenging task. Different types of bridges i.e., suspension, arch, and cable-stayed bridges behave differently in different conditions. Therefore, basic consideration is given to the sensor installation, data integration process, AR-interface adaptability, adaptability in data visualization, and user interface management. The developed application uses the VR background, which unifies the number of elements, thus, any kind of bridge with a different number of elements is considered as a single unit so the issue of geometric complexity is resolved. Further, the used IoT interface houses all kinds of sensors and facilitates the data integration processes. It involves robust algorithms for data visualization, data processing, and data transfer, accommodating complex and cumbersome data management. Moreover, the developed application is customized from scratch, so it is customizable and adaptable in nature, which can be easily modified as per the bridge design and monitoring requirements. The basic objective of selecting the extradosed bridge with such a long span (200 m) was to test the capabilities of the developed application over a complex structure and it was assumed that if this experiment is successful, it could be applicable to any other cable-stayed bridges, concrete girder bridges, concrete/steel arch bridges, and steel truss bridges. Thus, the successful implementation of research findings on this specific test case ensures the extension of these results to

other bridges. Such experimentation is also planned by the authors to test this application on every type of bridge so that a conclusive study about the implementation of AR can be published for different types of bridges.

**IX. MAJOR CHALLENGES AND THE ASSOCIATED RECOMMENDATIONS FOR FUTURE RESEARCH WORK**

The major challenge associated with this research includes the limited capabilities of AR headsets. To date, the available headsets have the limitation of the number of elements (< 10k) in the BIM models that can be visualized in AR. In the case of bridges, sometimes the number of elements in the BIM models is much higher than this limit. So, this issue has been addressed in the designed application where the bridge model is imported with the VR background, this way the whole structure acts as a single unit, and individual elements are not counted in numbers, which overcomes this problem. Besides this, there still exists an issue of using HoloLens in bright sun which causes visualization issues during the day time. To resolve this issue, it is recommended to carry out the field experimentation either during overcast weather conditions or should be done close to the sunset timings, to have better visualization of data. Additionally, the accuracy and reliability of wireless sensors integrated with AR applications may be affected by environmental factors such as temperature, humidity, and vibration. Therefore, further research is needed to overcome these limitations.

**X. CONCLUSION**

This research has focused on the advancements in the current bridge health monitoring practices by developing an Augmented Reality (AR) application that can be used in AR device (HoloLens) for the visualization and management of Structural Health Monitoring(SHM) data.

The major conclusions of this research are:

- Research work proposed the SHM system based on the Finite Element (FE) analysis results. The FE analysis of the bridge did not reveal any critical damage to the bridge. The results of internal forces, displacements, and stress controls are within the prescribed limit of the Euro Code (EC). The calculated crack width reaches the maximum value of 0.60 mm closer to the external support and the value around the mid supports is exactly equal to the value measured in the in-situ measurements. The deflected shape of cables is showing more sag in the first three cables suggesting a need for proper strain monitoring in these areas.
- Based on the results of numerical modeling and identified prone zones, the SHM system of the bridge is proposed. This system involves the installation of strain gauges (WSG) for the measurement of deformation in pylons and concrete slabs, Liquid Levelling Sensors (LLS) for the measurement of vertical displacement, LVDTs (LVD) for the measurement of linear displacements, MEMS Accelerometers (MA) for monitoring the effects of external loads on the structure especially

the dynamic effects of moving and the wind loads, and climate control station (WMS) for monitoring of wind speed, its direction, and measurement of temperature and humidity. This SHM system is supplemented with an Internet of Things(IoT)-based web platform that controls and manages the bridge health monitoring data. Three wireless sensors (WSG, MA, and WMS) are used as representatives of all sensors of this SHM system, and the data of these sensors is stored and visualized graphically over the IoT web platform.

- The development of the AR-based SHM system using an AR app is the major novelty of this research, which involves the applications of BIM and Augmented Reality(AR) technologies. This research carried out several attempts to access the web platform of the SHM system through the HoloLens device in AR, but it wasn't possible as there is no such application available that can perform the said job, so a proprietary application was developed in this research to do so. This application is developed in a 3D game engine i.e., UNITY 3D, and linked with the IoT web platform of the SHM system. The same application is successfully deployed to the HoloLens and SHM data is successfully visualized in HoloLens. This way, successful implementation of AR is ensured which makes it essential for bridge inspectors to visualize, analyze, store, and share the SHM data while being on site.

Thus, this paper provides a prototype of the AR-based SHM system that can smartly monitor bridge health and can be effectively used in the bridge industry.

## ACKNOWLEDGMENT

The authors acknowledge the facilitation of local administration of the bridge during the execution of the project. Further, they pay their sincere gratuities to local companies involved in the design and installation of the SHM system.

## REFERENCES

- [1] A. Strauss, K. Bergmeister, P. Daró, G. Mancini, F. Sattler, and A. B. van Vliet, "Monitoring and data-informed approaches for the assessment of existing structures," *Struct. Concrete*, vol. 24, no. 4, pp. 4433–4445, 2023.
- [2] G.-D. Zhou, T.-H. Yi, W.-J. Li, J.-W. Zhong, and G.-H. Zhang, "Standardization construction and development trend of bridge health monitoring systems in China," *Adv. Bridge Eng.*, vol. 1, no. 1, pp. 1–18, Dec. 2020.
- [3] M. Gatti, "Structural health monitoring of an operational bridge: A case study," *Eng. Struct.*, vol. 195, pp. 200–209, Sep. 2019. [Online]. Available: <https://www.sciencedirect.com/science/article/pii/S0141029618336563>
- [4] B. T. Svendsen, *Numerical and Experimental Studies for Damage Detection and Structural Health Monitoring of Steel Bridges*, doctoral theses NTNU:2021:382, 2021.
- [5] D. Ribeiro, R. Calçada, M. Brehm, and V. Zabel, "Calibration of the numerical model of a track section over a railway bridge based on dynamic tests," *Structures*, vol. 34, pp. 4124–4141, Dec. 2021. [Online]. Available: <https://www.sciencedirect.com/science/article/pii/S2352012421009577>
- [6] S. Alampalli, J. Grimson, M. Halling, D. Kosnik, E. O. L. Lantsoght, and Y. Zhou, "General load test preparation," in *Proc. Primer Bridge Load Test.*, 2019, pp. 18–26.
- [7] D. C. Nguyen, M. Salamak, A. Katunin, and M. Gerges, "Finite element model updating of RC bridge structure with static load testing: A case study of Vietnamese ThiThac bridge in coastal and marine environment," *Sensors*, vol. 22, no. 22, p. 8884, Nov. 2022.
- [8] M. Fawad, K. Koris, M. Salamak, M. Gerges, L. Bednarski, and R. Sienko, "Nonlinear modelling of a bridge: A case study-based damage evaluation and proposal of structural health monitoring (SHM) system," *Arch. Civil Eng.*, vol. 68, no. 3, pp. 569–584, 2022.
- [9] O. S. Sonbul and M. Rashid, "Algorithms and techniques for the structural health monitoring of bridges: Systematic literature review," *Sensors*, vol. 23, no. 9, p. 4230, Apr. 2023.
- [10] G. I. Zarate Garnica, E. O. L. Lantsoght, and Y. Yang, "Monitoring structural responses during load testing of reinforced concrete bridges: A review," *Struct. Infrastruct. Eng.*, vol. 18, nos. 10–11, pp. 1558–1580, Nov. 2022, doi: [10.1080/15732479.2022.2063906](https://doi.org/10.1080/15732479.2022.2063906).
- [11] C. Neves, *Structural Health Monitoring of Bridges: Data-Based Damage Detection Method Using Machine Learning*, doctoral theses TRITA-ABE-DLT-2027, KTH Roy. Inst. Technol., Stockholm, Sweden, 2020.
- [12] H. Li and J. Ou, "The state of the art in structural health monitoring of cable-stayed bridges," *J. Civil Struct. Health Monitor.*, vol. 6, no. 1, pp. 43–67, Feb. 2016, doi: [10.1007/s13349-015-0115-x](https://doi.org/10.1007/s13349-015-0115-x).
- [13] C. Dong, S. Bas, M. Debees, N. Alver, and F. N. Catbas, "Bridge load testing for identifying live load distribution, load rating, serviceability and dynamic response," *Frontiers Built Environ.*, vol. 6, p. 46, May 2020. [Online]. Available: <https://www.frontiersin.org/articles/10.3389/fbuil.2020.00046>
- [14] A. Mariak, M. Miskiewicz, B. Meronk, Ł. Pyrzowski, and K. Wilde, "Reference FEM model for SHM system of cable-stayed bridge in Rzeszów," in *Proc. 21st Int. Conf. Comput. Methods Mech. Adv. Mech., Theor., Comput. Interdiscipl.*, 2016, pp. 383–388.
- [15] S. Tahsin Noor, Md. S. Islam, and Md. A. Islam, "Monitoring of strut force in excavation for bridge pier using vibrating wire strain gauge," in *Proc. Int. Conf. Innov. Sci., Eng. Technol. (ICISSET)*, Oct. 2018, pp. 180–183.
- [16] G. Z. Garnica, F. Zhang, Y. Yang, C. van der Veen, E. Lantsoght, M. Naaktgeboren, and S. Fennis, "Monitoring structural responses during proof load testing of reinforced concrete bridges: A review," in *Proc. 10th Int. Conf. Bridge Maintenance, Saf. Manage. (IABMAS)*, 2021, p. 926.
- [17] S. T. Vegas, "A literature review of non-contact tools and methods in structural health monitoring," *Eng. Technol. Open Access J.*, vol. 4, no. 1, pp. 9–50, Jun. 2021.
- [18] X. Ye, Z. Sun, X. Cai, and L. Mei, "An improved step-type liquid level sensing system for bridge structural dynamic deflection monitoring," *Sensors*, vol. 19, no. 9, p. 2155, May 2019.
- [19] S. D. Mayunga and M. Bakaone, "Dynamic deformation monitoring of ltsane bridge using global positioning systems (GPS) and linear variable differential transducers (LVDT)," *J. Data Anal. Inf. Process.*, vol. 9, no. 1, pp. 30–50, 2021.
- [20] A. Sabato, "Pedestrian bridge vibration monitoring using a wireless MEMS accelerometer board," in *Proc. IEEE 19th Int. Conf. Comput. Supported Cooperat. Work Design (CSCWD)*, May 2015, pp. 437–442.
- [21] M. Omidalizari, R. Herrmann, B. Kargoll, S. Marx, J.-A. Paffenholz, and I. Neumann, "A validated robust and automatic procedure for vibration analysis of bridge structures using MEMS accelerometers," *J. Appl. Geodesy*, vol. 14, no. 3, pp. 327–354, Jul. 2020, doi: [10.1515/jag-2020-0010](https://doi.org/10.1515/jag-2020-0010).
- [22] M. Theiler, K. Dragos, and K. Smarsly, "Semantic description of structural health monitoring algorithms using building information modeling," in *Proc. Adv. Comput. Strategies Eng.*, I. F. C. Smith and B. Domer, Eds. Cham, Switzerland: Springer, 2018, pp. 150–170.
- [23] R. Li, T. Mo, J. Yang, S. Jiang, T. Li, and Y. Liu, "Ontologies-based domain knowledge modeling and heterogeneous sensor data integration for bridge health monitoring systems," *IEEE Trans. Ind. Informat.*, vol. 17, no. 1, pp. 321–332, Jan. 2021.
- [24] S. Jeong, R. Hou, J. P. Lynch, H. Sohn, and K. H. Law, "An information modeling framework for bridge monitoring," *Adv. Eng. Softw.*, vol. 114, pp. 11–31, Dec. 2017. [Online]. Available: <https://www.sciencedirect.com/science/article/pii/S0965997817300777>
- [25] A. Scianna, G. F. Gaglio, and M. La Guardia, "Structure monitoring with BIM and IoT: The case study of a bridge beam model," *ISPRS Int. J. Geo-Inf.*, vol. 11, no. 3, p. 173, Mar. 2022.
- [26] C. Arcadius Tokognon, B. Gao, G. Y. Tian, and Y. Yan, "Structural health monitoring framework based on Internet of Things: A survey," *IEEE Internet Things J.*, vol. 4, no. 3, pp. 619–635, Jun. 2017.

- [27] L. Deng, S. Lai, J. Ma, L. Lei, M. Zhong, L. Liao, and Z. Zhou, "Visualization and monitoring information management of bridge structure health and safety early warning based on BIM," *J. Asian Archit. Building Eng.*, vol. 21, no. 2, pp. 427–438, Mar. 2022.
- [28] G. Su and K. Kensek, "A BIM-based visualization tool for facilities management: Fault detection through integrating real-time sensor data into BIM," *J. Architectural Eng. Technol.*, vol. 9, Dec. 2020.
- [29] X. Li, Y. Xiao, H. Guo, and J. Zhang, "A BIM based approach for structural health monitoring of bridges," *KSCE J. Civil Eng.*, vol. 26, no. 1, pp. 155–165, Jan. 2022.
- [30] M. Husinsky, A. Schlager, A. Jalaeefar, S. Klimpfinger, and M. Schumach, "Situating visualization of IIoT data on the HoloLens 2," in *Proc. IEEE Conf. Virtual Reality 3D User Interfaces Abstr. Workshops (VRW)*, Mar. 2022, pp. 472–476.
- [31] D.-C. Nguyen, T.-Q. Nguyen, R. Jin, C.-H. Jeon, and C.-S. Shim, "BIM-based mixed-reality application for bridge inspection and maintenance," *Construct. Innov.*, vol. 22, no. 3, pp. 487–503, Jun. 2022.
- [32] A. Sadhu, J. E. Peplinski, A. Mohammadkhorasani, and F. Moreu, "A review of data management and visualization techniques for structural health monitoring using BIM and virtual or augmented reality," *J. Struct. Eng.*, vol. 149, no. 1, Jan. 2023, Art. no. 03122006.
- [33] O. Awadallah and A. Sadhu, "Automated multiclass structural damage detection and quantification using augmented reality," *J. Infrastruct. Intell. Resilience*, vol. 2, no. 1, 2023, Art. no. 100024.
- [34] R. Napolitano, A. Blyth, and B. Glisic, "Virtual environments for visualizing structural health monitoring sensor networks, data, and metadata," *Sensors*, vol. 18, no. 1, p. 243, Jan. 2018.
- [35] V. Palma, G. Iovane, S. Hwang, F. M. Mazzolani, R. Landolfo, H. Sohn, and B. Faggiano, "Innovative technologies for structural health monitoring of SFTs: Proposal of combination of infrared thermography with mixed reality," *J. Civil Struct. Health Monitor.*, vol. 13, no. 8, pp. 1653–1681, Dec. 2023.
- [36] Y. Gao, H. Li, G. Xiong, and H. Song, "AIoT-informed digital twin communication for bridge maintenance," *Autom. Construct.*, vol. 150, Jun. 2023, Art. no. 104835. [Online]. Available: <https://www.sciencedirect.com/science/article/pii/S092658052300095X>
- [37] A. Jiménez Rios, V. Plevris, and M. Nogal, "Bridge management through digital twin-based anomaly detection systems: A systematic review," *Frontiers Built Environ.*, vol. 9, Apr. 2023. [Online]. Available: <https://www.frontiersin.org/articles/10.3389/fbuil.2023.1176621>
- [38] *Eurocode 1: Actions structures. Part 2. Moving Loads Bridges*, Eur. Union Standard PN-EN 1991-2:2007, 2007.
- [39] *Bridge Structural Loads*, Polish Committee Standardization Standard PN 85/S-10030:1985, 1985.
- [40] C. Schranz, H. Urban, and A. Gerger, "Potentials of augmented reality in a BIM based building submission process," *J. Inf. Technol. Construct.*, vol. 26, pp. 441–457, Jul. 2021, doi: [10.36680/j.itcon.2021.024](https://doi.org/10.36680/j.itcon.2021.024).
- [41] H. Nassereddine, A. S. Hanna, D. Veeramani, and W. Lotfollah, "Augmented reality in the construction industry: Use-cases, benefits, obstacles, and future trends," *Frontiers Built Environ.*, vol. 8, Dec. 2022. [Online]. Available: <https://www.frontiersin.org/articles/10.3389/fbuil.2022.730094>
- [42] A. Elshafey, C. C. Saar, E. B. Aminudin, M. Gheisari, and A. Usmani, "Technology acceptance model for augmented reality and building information modeling integration in the construction industry," *J. Inf. Technol. Construct.*, vol. 25, pp. 161–172, Mar. 2020, doi: [10.36680/j.itcon.2020.010](https://doi.org/10.36680/j.itcon.2020.010).
- [43] T. Inc. (2023). *Trimble Connect for Revit Add-in User Guide*. [Online]. Available: <https://docs.revit.connect.trimble.com/>
- [44] M. Fawad, M. Salamak, A. Al-hijazeen, and K. Kalman, "Applications of AR/MR technology for the visualization of future bridge concepts—Part 2," *e-BrIM*, vol. 1, pp. 57–66, Jun. 2023. [Online]. Available: <https://e-brim.com/bim-for-bridges-february-2023/>
- [45] N. A. Kamaluddin, M. Kassim, and H. Kassim, "3D augmented reality marker-based mobile apps design of face mask layer," *Int. J. Informat. Vis.*, vol. 7, no. 1, p. 44, Jan. 2023.
- [46] A. Malaweera, R. Jogi, M. Wright, M. O'Neill, and S. Williams, "A mixed-reality holographic viewing platform enabling interaction with 3D electroanatomical maps using the HoloLens," *Eur. Heart J.*, vol. 42, no. 1, Oct. 2021, Art. no. ehab724, doi: [10.1093/eurheartj/ehab724.0371](https://doi.org/10.1093/eurheartj/ehab724.0371).
- [47] M. Fawad, M. Salamak, G. Poprawa, K. Koris, M. Jasinski, P. Lazinski, D. Piotrowski, M. Hasnain, and M. Gerges, "Automation of structural health monitoring (SHM) system of a bridge using BIMification approach and BIM-based finite element model development," *Sci. Rep.*, vol. 13, p. 13225, Aug. 2023, doi: [10.1038/s41598-023-40355-7](https://doi.org/10.1038/s41598-023-40355-7).



**MUHAMMAD FAWAD** received the M.Sc. degree in structural engineering from the Budapest University of Technology and Economics, Hungary. He is currently pursuing the joint Ph.D. degree with the Budapest University of Technology and Economics and the Silesian University of Technology Poland. He is engaged in Ph.D. research work involving the use of BIM technology and cyber-physical devices for the structural health monitoring (SHM) of bridges.

He is working on the use of virtual reality (VR) and mixed reality (AR) devices, such as Microsoft HoloLens. Site Vision, and Oculus Quest, supplemented with wireless sensors for bridge health monitoring. He has been a member of the Pakistan Engineering Council, since 2015.



**MAREK SALAMAK** received the Ph.D. degree from the Silesian University of Technology, Poland. He is currently an Associate Professor with the Silesian University of Technology. He is an Bridge Engineer, an Expert in CAD, BIM, and digitization of construction, and the Creator of an accredited research laboratory for bridge structures. He is the author or coauthor of over 150 publications, including the book *BIM in the Life Cycle of Bridges*.



**MUHAMMAD USMAN HANIF** is currently an Assistant Professor with the National University of Sciences and Technology. He is a Postdoctoral Researcher with the Korea National University of Transportation, where he is researching damage monitoring of FRP retrofitted concrete structures using acoustic emissions. He specializes in structural diagnostics and damage assessment using vibrations and acoustics. His research is primarily focused on SHM of reinforced concrete structures

which involves sensor instrumentation, signal processing, large data analysis, and damage characterization.



**KÁLMÁN KORIS** received the Ph.D. degree from the Budapest University of Technology and Economics, in 1993. He is currently an Associate Professor with the Department of Structural Engineering, Budapest University of Technology and Economics. He is a Civil Engineer. His research interests include safety of reinforced concrete structures, analysis of prefabricated, prestressed concrete structures, strengthening of structures, and timber structures. He is a member of the Standardization Subcommittee "NAD MSZ ENV 1992 Eurocode 2, Design of Concrete Structures" and the Hungarian Chamber of Engineers. He is a member of the Hungarian Group of Fib and the Public Body of the Hungarian Academy of Sciences. He is a Presidential Member of the Construction Board of the Hungarian Chamber of Engineers.



**MUHAMMAD AHSAN** received the bachelor's degree in electrical engineering from Air University, Islamabad, Pakistan, in 2013, and the M.Sc. degree in control theory and control engineering from the Nanjing University of Science and Technology, Nanjing, China, in 2020.

In October 2020, he joined the Silesian University of Technology, Gliwice, Poland. Since then, he has been actively involved in cutting-edge research focused on developing innovative digital signal processing techniques, control engineering, and artificial intelligence methods. His work aims to enhance the reliability and efficiency of these systems, contributing to safer and more robust industrial operations.



**HADIYA RAHMAN** received the bachelor's and M.Sc. degrees in project management from Riphah International University, Islamabad, Pakistan, in 2015 and 2021, respectively. She is currently pursuing the Ph.D. degree with the Faculty of Management, Wrocław University of Science and Technology. Her focus is on resilient management using circular economy principles for more sustainable management models.



**MICHAEL GERGES** is an internationally recognized Scholar and a Subject Matter Expert as evidenced by his editorship of learned journals, of international appointments as an advisory board member in international bodies. He is an active Researcher in the fields of fire engineering (behavior of construction materials under elevated temperature, human behavior in fire conditions, fire safety design of buildings, and evacuation modeling), building information modelling, digital construction, and infrastructure management. In addition, he is a guest speaker at several universities in the Middle East and Asia (Jordan, Oman, Egypt, Kuwait, Lebanon, UAE, Saudi Arabia, India, Hong Kong, and Sri Lanka). During his academic career, he led CPD courses related to internationalism, distance learning, curriculum development, teaching, and learning.



**MOSTAFA MOHAMED SALAH** (Member, IEEE) received the bachelor's degree from Future University in Egypt, Cairo, Egypt, in 2013, and the M.Sc. and Ph.D. degrees from the Electronics and Communications Engineering Department, Faculty of Engineering, Ain Shams University, in 2018 and 2023, respectively.

Since February 2023, he has been an Assistant Professor with the Electrical Engineering Department, Future University in Egypt, where he continues to conduct research in the same field.

...