

Received 12 September 2023, accepted 16 September 2023, date of publication 22 September 2023,  
date of current version 3 October 2023.

Digital Object Identifier 10.1109/ACCESS.2023.3318121

TOPICAL REVIEW

# Advances in Batteries, Battery Modeling, Battery Management System, Battery Thermal Management, SOC, SOH, and Charge/Discharge Characteristics in EV Applications

R. RANJITH KUMAR<sup>1,2</sup>, C. BHARATIRAJA<sup>1,2</sup>, (Senior Member, IEEE),  
K. UDHAYAKUMAR<sup>1</sup>, S. DEVAKIRUBAKARAN<sup>1,2</sup>, K. SATHIYA SEKAR<sup>3</sup>,  
AND LUCIAN MIHET-POPA<sup>1,4</sup>, (Senior Member, IEEE)

<sup>1</sup>Department of Electrical and Electronics Engineering, Anna University, Chennai 600025, India

<sup>2</sup>Center for Electric Mobility, Department of Electrical and Electronics Engineering, SRM Institute of Science and Technology, Chennai 603203, India

<sup>3</sup>Department of Electrical and Electronics Engineering, KSR Institute for Engineering and Technology, Tiruchengode, Tamil Nadu 637215, India

<sup>4</sup>Faculty of Information Technology, Engineering and Economics, Østfold University College, 1757 Halden, Norway

Corresponding authors: C. Bharatiraja (bharatic@srmist.edu.in) and Lucian Mihet-Popa (lucian.mihet@hiof.no)

This work was supported by the Department of Science and Technology, Government of India, Promotion of University Research and Scientific Excellence (PURSE), under Award SR/PURSE/2021/65.

**ABSTRACT** The second-generation hybrid and Electric Vehicles are currently leading the paradigm shift in the automobile industry, replacing conventional diesel and gasoline-powered vehicles. The Battery Management System is crucial in these electric vehicles and also essential for renewable energy storage systems. This review paper focuses on batteries and addresses concerns, difficulties, and solutions associated with them. It explores key technologies of Battery Management System, including battery modeling, state estimation, and battery charging. A thorough analysis of numerous battery models, including electric, thermal, and electro-thermal models, is provided in the article. Additionally, it surveys battery state estimations for a charge and health. Furthermore, the different battery charging approaches and optimization methods are discussed. The Battery Management System performs a wide range of tasks, including as monitoring voltage and current, estimating charge and discharge, equalizing and protecting the battery, managing temperature conditions, and managing battery data. It also looks at various cell balancing circuit types, current and voltage stressors, control reliability, power loss, efficiency, as well as their advantages and disadvantages. The paper also discusses research gaps in battery management systems.

**INDEX TERMS** Electric vehicle, battery management, battery modelling, state of charge, state of health, cell balancing, battery thermal management system.

## I. INTRODUCTION

The effects of fossil fuel depletion on the ecosystem have increased the urgency to transition to renewable energy sources and alternative transportation technologies. The excessive extraction and utilization of fossil fuels result in the generation of significant quantities of CO<sub>2</sub> and other

The associate editor coordinating the review of this manuscript and approving it for publication was Branislav Hredzak<sup>1</sup>.

greenhouse gas emissions (GHGE). Utilizing renewable energy sources and electrifying the transportation sector, as shown in Fig. 1, can reduce the GHGE by up to 40%. Renewable energy, such as solar, wind, wave, and tidal power provides a greener, more sustainable alternative to fossil fuels [1]. However, the intermittent nature of these energy sources poses a challenge to maintaining a consistent and reliable power supply. To tackle this challenge, energy storage systems (ESSs) are utilized to store surplus energy generated

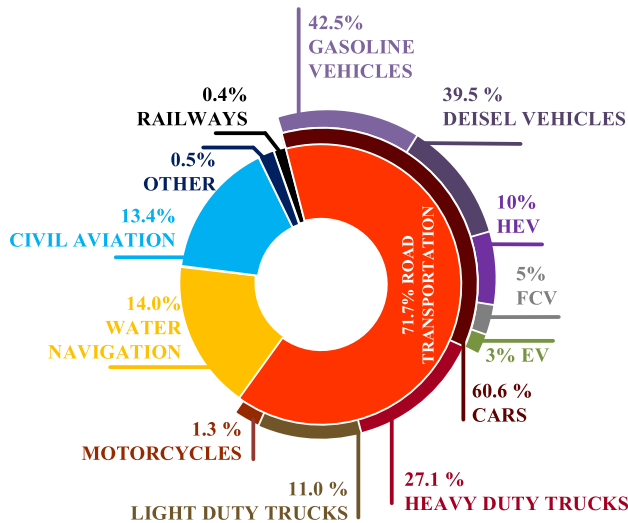

FIGURE 1. Vehicle CO2 emission levels.

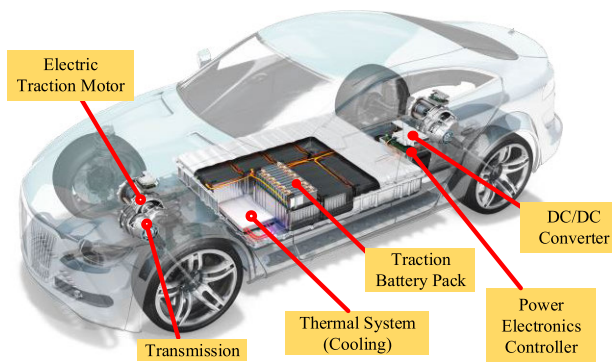

FIGURE 2. A standard electric vehicle.

from renewable sources during peak production periods and release it to the grid during high demand or when renewable energy generation is low.

The ESSs play a crucial part in boosting the viability and stabilizing the power grid of the widespread adoption of renewable energy sources. EV (shown in Fig.2) and hybrid electric vehicles (HEVs) have gained popularity as potential replacements for automobiles powered by internal combustion engines, offering numerous benefits such as reduced greenhouse gas emissions, decreased air pollution, and improved energy efficiency.

EVs and HEVs are powered by batteries, which offer features include high energy density, low environmental impact, and durable performance. The wider adoption of EVs depends on advancements in battery technology. Efforts are being made to enhance energy storage capacity, reduce charging times, and lower costs. Currently, Lithium-ion (Li-ion) batteries are the most prevalent type used in EVs due to their favorable characteristics, but researchers are also exploring other battery chemistries as shown in Fig.3.

This concept allows EVs not only to consume energy but also to function as energy storage systems, actively engaging

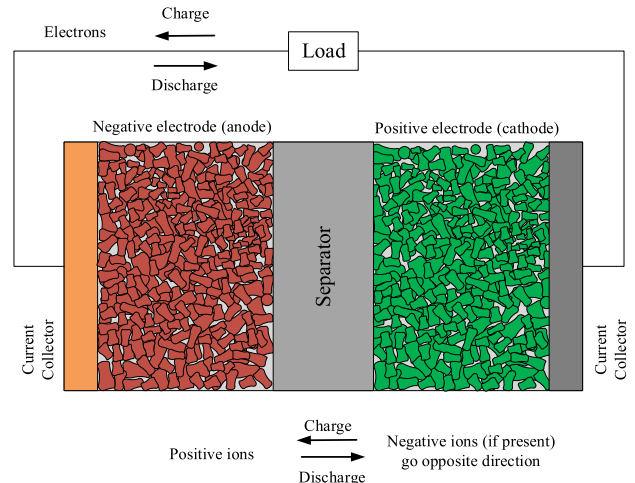
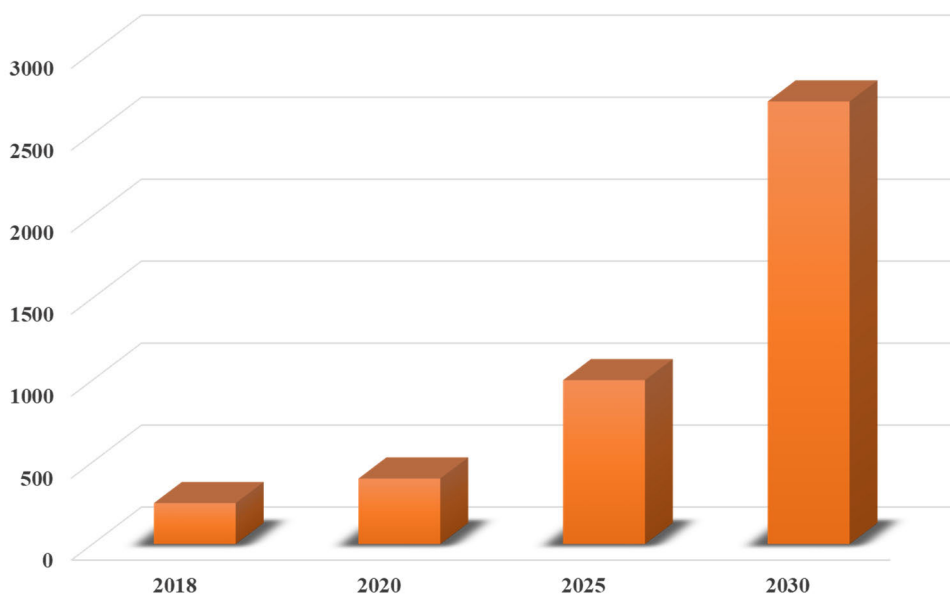

FIGURE 3. Schematic diagram of Li-ion cell.

with the electrical grid. During periods of low demand or high renewable energy generation, EVs can supply stored electricity back to the grid, thereby assisting in balancing supply and demand and promoting grid stability. Fig. 4 demonstrates the worldwide battery industry’s explosive expansion, projecting a surpass of 2500 GWh within the next decade [119]. Fig. 4 (b) showcases the increasing demand for batteries across different applications and regions, with electric mobility being a major driving force behind the growth of the modern battery industry. The popularity of electric and alternative fuel vehicles is accelerating the research and development of battery materials and automotive technology, which supports smart mobility. China has made plans to meet its peak emissions before 2030, in keeping with the global goal of achieving carbon neutrality. To make electric vehicles comparable to fossil fuel vehicles, Li-ion Batteries (LIBs) are expected to come to an energy density goal of approximately 500 Wh kg<sup>-1</sup> for EV applications. Numerous electric car models have made extensive use of both Li-ion batteries and nickel-metal hydride (Ni-MH) batteries [3]. The popularity of Li-ion batteries stems from their improved reliability, power density, energy density, and efficiency [4]. Additionally, the decreasing manufacturing costs of Li-ion batteries have contributed significantly to their widespread commercialization, enabling their adoption across multiple industries. Efficient battery management is crucial to ensure safe use, increase driving range, improve power management techniques, lengthen battery life, and lower costs. Batteries require specific attention in electric vehicle applications. Overcharging, over discharging, or other improper activities can pose serious safety threats to the batteries, hasten their ageing process, and potentially result in fire or explosion accidents [5]. Battery systems in electric vehicles not only power the electric motor but also different electrical components. These vehicles often operate under complex conditions characterized by frequent acceleration and deceleration, and human charging behavior can be unpredictable.

### Global Battery Demand (GWh)



(a)

Year 2018

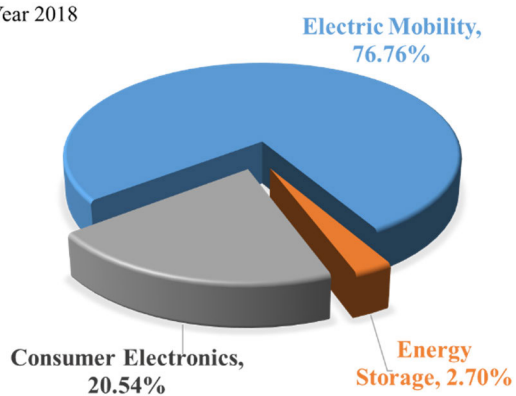

Year 2020

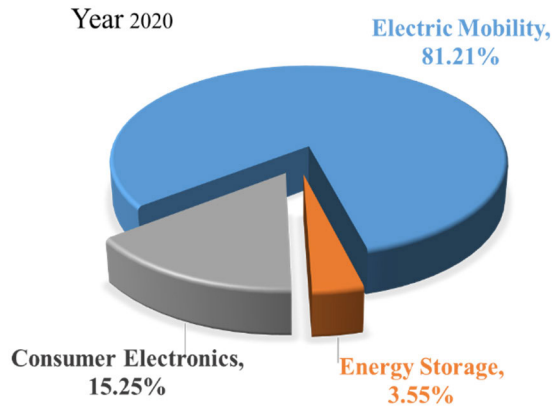

Year 2025

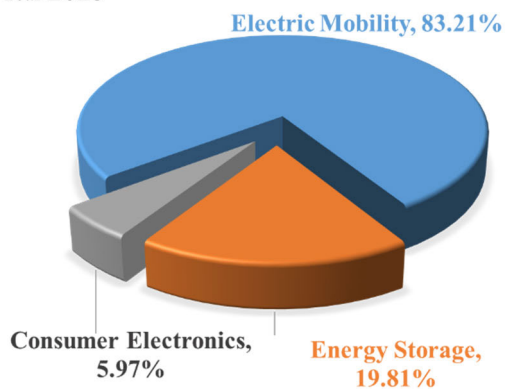

Year 2030

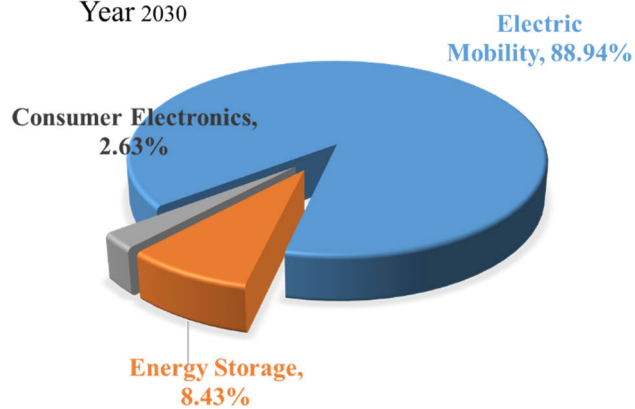

(b)

FIGURE 4. Global battery industry. (a) Growth. (b) Demands by applications.

Additionally, because the battery is an electrochemical system, state determination is quite challenging due to the battery high nonlinearity and time-varying characteristics [6]. Therefore, creating precise and dependable BMS technologies is still a challenging effort to guarantee that batteries and the associated energy systems operate in a secure manner and function to the best of their abilities. This paper aims to give detailed review is Focuses on a Battery management system and key technologies for BMS in Section.II. The typical batteries used in EV are reviewed in Section.III. Discussed Various types of Battery Modelling the typical batteries used in EV in Section.IV. Various SOC estimation Techniques are discussed for Battery Cell and Battery Pack in Section V. Comprehensive review of Various Battery SOH estimation in Section.VI. Several Important and Conventional battery charging Strategies are covered, along with the related optimization techniques in Section VII. Focuses on various cell balancing topologies has been recommended in recent years in Section VIII. It provides and overview of the most recent advance in LIB thermal management for high charge/discharge cycles in Section VIII. The problems with BMS are discussed. the viewpoint of BMS improvement is examined in Section IX. A summary of the viewpoints of the current study and the Suggested future research activity of BMS is Provided in Section.X. Finally, the conclusion of the paper is summarized in Section XI.

## II. BATTERY MANAGEMENT SYSTEM

The state of charge (SOC), state of health (SOH), state of energy (SOE), state of power (SOP), and state of life (SOL) are just a few examples of estimations covered by battery management technologies (SOL). Among these, SOC and SOH monitoring are particularly crucial as they serve as the foundation for enhancing reliability and ensuring safety. A software and hardware device called a BMS is intended to control batteries and optimize their performance [7], as depicted in Fig. 6.

The BMS software serves as the central component of the system, responsible for controlling hardware operations and analyzing sensor data to make informed decisions. Online data processing plays a critical role in detecting most faults, and intelligent data analysis is necessary to provide timely battery malfunction warnings. Data collection is of paramount importance to identify potential issues before they manifest as faults. Hardware components within the BMS, such as sensors, make it easier to measure battery voltage and current. The general block diagram of a BMS is illustrated in Fig. 7. A BMS comprises various functional units, including cell voltage balancing, temperature monitoring, current sensing, and communication interfaces. Cell voltage balancing guarantees that each battery pack's individual cells are maintained at consistent voltage levels, maximizing the overall pack performance and extending its lifespan. Temperature monitoring is crucial for preventing overheating and managing thermal conditions within the battery. Current sensing enables accurate measurement and monitoring of

the battery electric current is going in and out. Communication interfaces facilitate the information transfer between external devices and the BMS such as the vehicle's control system or a battery management network. To protect the battery from potentially harmful circumstances, the BMS also includes safety functions including over-current protection, over-voltage protection, and under-voltage protection. Furthermore, The BMS is in charge of managing the charging and discharging procedures, ensuring they are carried out within safe and optimal parameters.

In the market, there exist various types of integrated BMS chips that offer different functionalities. These chips are designed to perform specific tasks within the BMS architecture. Some of the common functional components found in BMS chips are a fuel gauge monitor, a cut-off field effect transistor, a cell voltage monitor, a state machine, temperature monitors, and a real-time clock [8]. The organization and integration of these components can vary depending on the specific BMS chip. BMS chips can range from simpler analog front ends with microcontrollers capable of monitoring and balancing to fully integrated solutions that can operate autonomously. The level of integration and complexity depending on the applications needs the desired functionality of the BMS. In EVs, Different types of actuators, controllers, and sensors can be included in BMS. These components work together to ensure the safe and wide range of actuators, controllers, and sensors can be used with BMS. The BMS also performs accurate monitoring of battery parameters, providing valuable information for battery health assessment, state of charge estimation, and overall battery performance optimization [9]. In terms of hardware architecture, there are three basic types of topologies that are frequently employed in BMS: modular architectures, centralized systems, and distributed systems. BMS can also be categorized according to the particular features they have [10]. These ideas offer a comprehensive framework with fundamental functionality for BMS design. Within the battery pack, various sensors are strategically placed to collect data at the monitoring layer [11]. All of the battery pack's elements and the vehicle control processor are connected to the BMS. Safety has always been a top priority for BMS. The suggested BMS designs, however, use more sensors than the safety circuits now in use, allowing for improvements like accurate warnings and controls to prevent overcharging, over discharging, and overheating. A system of sensors is necessary to track and quantify battery properties such cell voltage, current, and temperature. However, the practical viability of these measurements is hindered by space limitations and the cost of devices. As a result, accurate measurements of current, temperature, and voltage are crucial to improving state tracking capabilities in practical applications. Based on these data, SOC, SOH, State estimations were been obtained. Also the surface temperature is measured to attain the thermal characteristic and the impact of temperature with the battery SOC and SOH were obtained. Along with this the battery joint state estimation has been measured using the above two data. This joint state

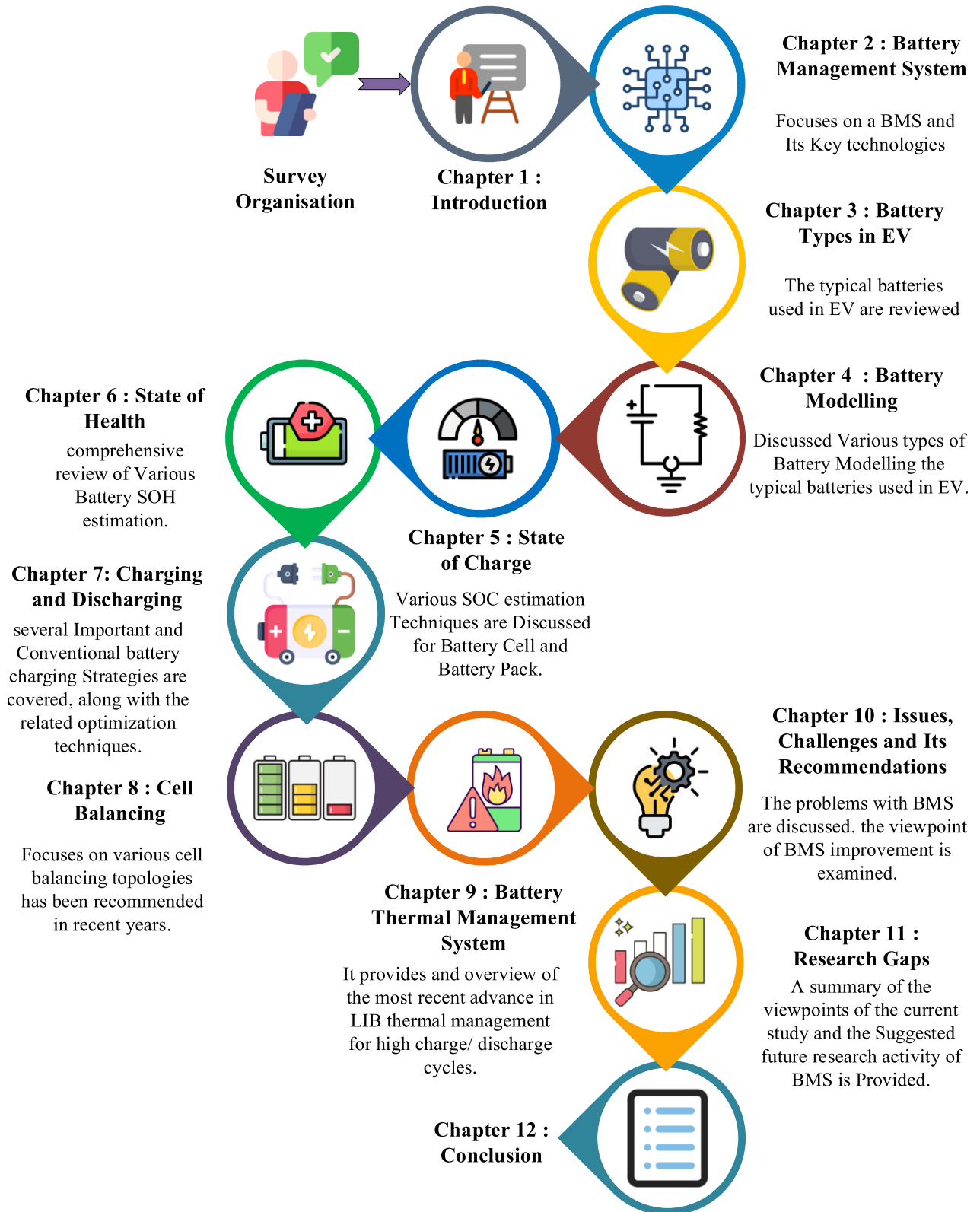

**FIGURE 5.** Organization of the review article.

estimation is a important measure for the battery to effectively manage and operate the battery and increases the battery life span in different types of applications such as electric

vehicles, renewable energy storage, and so on. These attained parameters has been used for defining the charging behavior, fault monitoring, fault/abnormal detection, predictive control

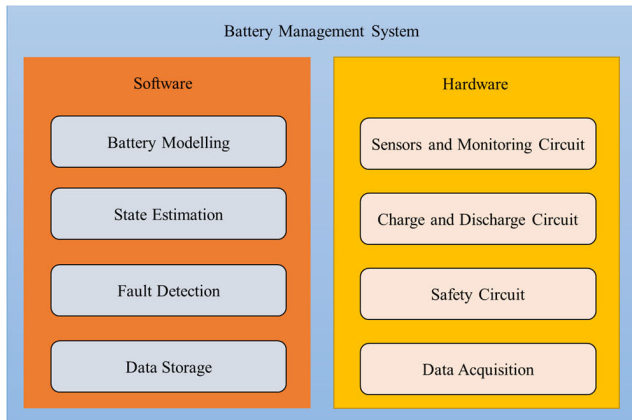

FIGURE 6. Overview of the BMS hardware and software components.

and fault diagnosis. The various steps like, obtaining the appropriate data, modeling, data collection, and data storage as shown as a block diagram in Fig.8.

One part of the system that controls the charge-discharge cycle is the charge controller. A variable resistor could be needed to maintain cell balance or check internal resistance. Cell balancing management, which aims to balance the battery pack's cells and accurately gauge the battery health, is one of the most crucial design factors. BMS subsystems must communicate internally because they are independent modules. A Controller Area Network (CAN) bus is used as the main means of communication within the BMS for the transfer of data. By implementing intelligent batteries with embedded microchips that can communicate with users and chargers, more information can be obtained. In order to increase connection between the battery and charger, radio and communication technologies are also being rapidly included into charging systems. Because temperature variations can have an impact on cell imbalance, dependability, and performance, a thermal management module is required. Reduced temperature differences between cells are critical, ensuring they operate under appropriate temperature conditions to maintain optimal performance and longevity. Different sensors, actuators, controllers, and signal lines are all included in BMS. Its main job is to make sure that the battery stored energy is used safely and optimally while giving the car's energy management system reliable information about the battery condition. In the sample circuit depicted in Fig.6 [112], Using the gating signal that is received from the control circuit as a starting point, the primary goal is to measure current, voltage, and temperature. The control circuit utilizes advanced algorithms to estimate the SOC, SOH, SOP, and SOL of the batteries. These estimates are obtained from measurements of battery current, voltage, and temperature, which are converted from analog signals. The resulting information is then sent to the vehicle controller, giving key deciding elements for the management and distribution of power in vehicles [12], [13], [14]. The functionality of a BMS can be categorized as follows [15]:

1. Protection: This entails preventing the battery from being damaged by high temperatures, overcharging, overcurrent, and short circuits.
2. In the field of "high-voltage control and sensing," tasks including measuring temperature, voltage, current, thermal management, contactor control, pre-charge functionality, and ground-fault detection are included.
3. Diagnostics: The SOL estimate, SOH estimation, and abuse detection functions of the BMS are used to assess the battery overall health and condition.
4. Performance Management: This encompasses tasks such as power-limit computation, cell balancing or equalization, and SOC estimation, which is crucial for optimizing battery performance.
5. Interface: The BMS facilitates data recording, reporting, communications, and range estimation, allowing for effective communication and integration with other vehicle systems.

By fulfilling these functions, the BMS ensures the battery system's effectiveness, dependability, and safety while providing essential information for the management and utilization of vehicular energy

### III. BATTERY TYPES IN EV

Various types of batteries can be utilized as the power EV applications as given in Fig. 9. The BMS consists of multiple functional modules. In this study, popular battery types and key BMS technologies are analysed and condensed. According to their capacity for charging, batteries can be divided into two general categories: primary batteries and secondary batteries. Secondary batteries can be recharged following the discharge process, however primary batteries can only be used once after being entirely depleted. Secondary batteries with a high cycle life, a low power density, a low energy loss, and sufficient safety levels are required for EV and HEV applications. Some commonly used battery types in EVs include Li-ion, lead acid, nickel-cadmium (NiCd), and NiMH, among others and the evolution of the batteries with respect to its timeline is shown in Fig. 10. Key details for these well-liked battery types are presented in Table 2. This clearly demonstrates that Li-ion batteries exhibit significant advantages over other types, in terms of their longer cycle life, which is essential for ensuring long service life in EVs (typically 6-10 years) [3]. Additionally, Li-ion batteries are made of environmentally acceptable components, don't emit any hazardous gases, and provide a high level of safety. As a result, Li-ion batteries are now the most widely used kind of EV power. Lithium-based batteries have the highest cell potential and the lowest reduction potential when compared to other elements as given Table 3. Lithium is one of the single-charged ions with one of the smallest ionic radii, making it the third-lightest element in terms of mass. These qualities allow Li-based batteries to attain high power density, gravimetric capacity, and volumetric capacity [16]. The Li-ion battery exhibits an energy density range of 200-250 Wh/kg and boasts a high coulombic efficiency of

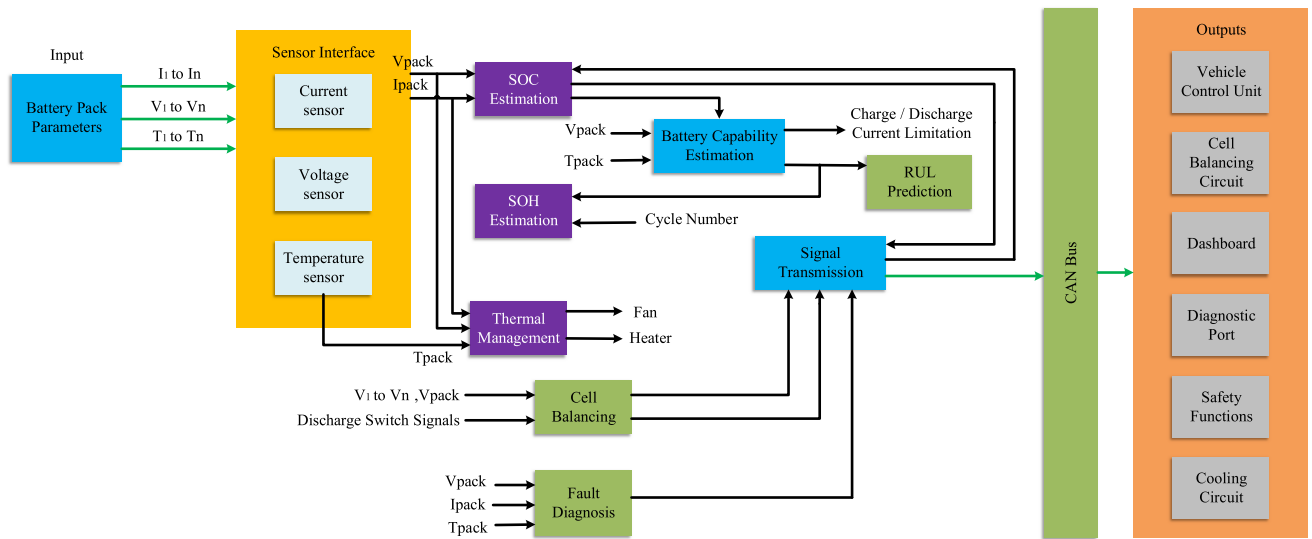

FIGURE 7. Battery management system functional block diagram.

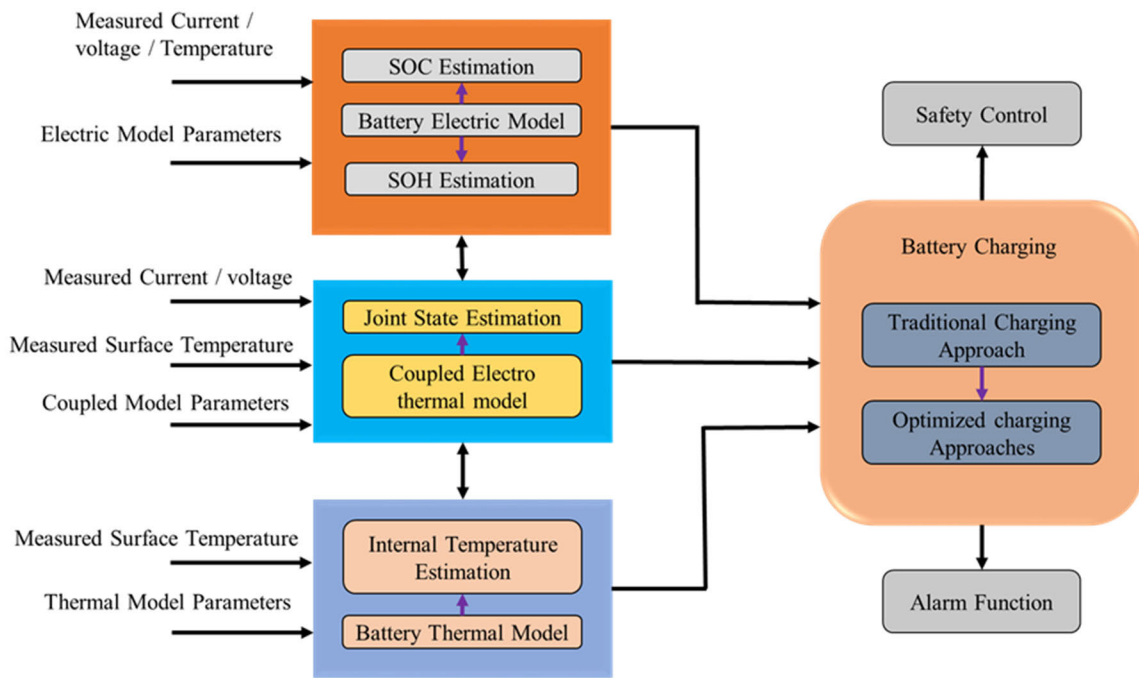

FIGURE 8. Key technologies of BMS.

nearly 100% [17]. It is also free from memory effect. Due to its superior energy and power density compared to lead-acid and Ni-Cd batteries, lithium-ion batteries are now the preferred choice. It is widely utilised in many different products, such as electric automobiles, power equipment, and portable gadgets [18], [19], [20]. Li-ion battery development is ongoing with the goal of increasing their cycle life and safety in both normal and abusive situations [21], and overall performance characteristics. In the pursuit of higher energy density for electric vehicles, researchers have explored

alternative electrochemical energy storage systems. One such technology is the lithium-sulfur (Li-S) battery, which offers advantages for instance, increased energy density, enhanced security, a larger operational temperature range, and maybe lower prices due to the abundance of sulfur. These factors make Li-S batteries a promising option for EV applications [22]. Energy density and specific energy of various batteries at cell level is shown in Fig. 11. However, widespread commercialization of lithium-sulfur technology has not yet been achieved due to certain limitations. These excessive discharge

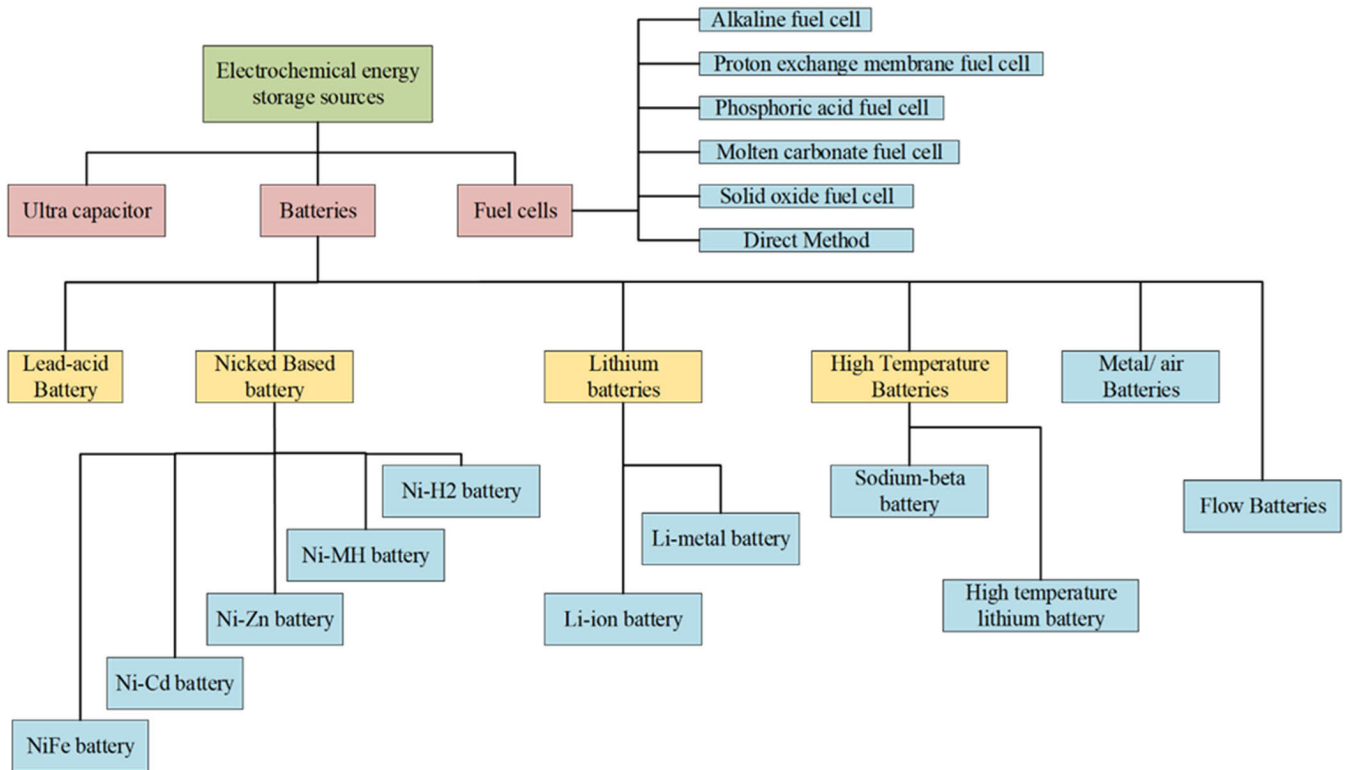

FIGURE 9. Classification of electrochemical energy storage sources.

current, self-discharge, poor cycle life and capacity decline brought on by cycling, low columbic efficiency, uncontrolled dendrite development, and other factors.

**A. BATTERY TECHNOLOGIES BEYOND LITHIUM**

Extensive research has been done on battery technologies other than lithium as LIBs get close to their natural limits in terms of specific energy and energy density. Three different battery types have developed as alternative technologies in recent decades:

1) 3.1.1 METAL/AIR BATTERIES

Anodes made of metal and cathodes made of air are used in metal/air batteries. The energy capacities of these batteries are primarily determined by the anode capacity and the handling process. Despite this limitation, they offer exceptionally high energy density and specific energy, with maximum values of 400 and 600 Wh/L, respectively. Zinc/air, aluminum/air, iron/air, magnesium/air, calcium/air, and lithium/air batteries are only a few examples of the several kinds of metal/air batteries that are available. These batteries can be classified as primary (non-rechargeable), electrically rechargeable, or mechanically rechargeable. Among them, mechanically rechargeable batteries provide the convenience of refueling and recycling.

2) SODIUM-BETA BATTERIES

High energy density is a well-known characteristic of sodium-beta batteries, although researchers have successfully

developed only two technologies in this field. These include sodium/sulfur (Na/S) batteries and sodium/metal chloride (Na/MCl<sub>2</sub>) batteries. These batteries must function at high temperatures between 270 and 350 °C in order to achieve the necessary ionic conductivity.

3) SODIUM/METAL CHLORIDE (NA/MCL<sub>2</sub>) BATTERY

Na/MCl<sub>2</sub> batteries use transition metal chloride as the cathode material. In particular, Na/FeCl<sub>2</sub> and Na/NiCl<sub>2</sub> batteries are made using iron chloride and nickel chloride, respectively. Among these, the Na/FeCl<sub>2</sub> battery has undergone more significant development compared to the Na/NiCl<sub>2</sub> battery. The Na/NiCl<sub>2</sub> battery offers several advantages, including increased power density, a wider working temperature range, and less corrosion of metallic elements.

4) SODIUM/SULFUR BATTERY

The Na/S battery uses beta-alumina ceramic electrolyte, sodium anode, and sulphur cathode. However, the performance of Na/S batteries tends to decline as the internal resistance increases, which is further exacerbated by deeper discharges. In recent research, there has been exploration into room-temperature Na/S batteries that demonstrate robust and consistent cycling performance [115], [116].

**IV. BATTERY MODELLING**

The core of BMS design is building an accurate battery model, which is essential for estimating the battery status. Battery models vary in terms of accuracy and complexity,



TABLE 1. Nomenclature.

°C	Degree celsius
AC	Alternating current
AEKF	Adaptive Extended Kalman Filter
Ah	Ampere hour
AI	Artificial Intelligence
ANN	Artificial Neural Network
AUKF	Adaptive Unscented Kalman Filter
BC	Boost Charging
BESS	Battery energy Storage systems
BMS	Battery Management System
BTMS	Battery thermal management system
C <sub>0</sub> , C <sub>1</sub> , C <sub>2</sub>	Equivalent Capacitance of the Cell
CAN	Controller Area Network
C <sub>B</sub> , C <sub>e</sub>	Plate capacitance
CC	Constant Current Charging
CCCV	Constant Current Constant voltage charging
C <sub>n</sub>	Battery Nominal Capacity
CO <sub>2</sub>	Carbon Di-oxide
C <sub>p</sub>	Equivalent to the impedance received upon transport between li-ion electrode
CTC	Constant Tickle Charging
CV	Constant Voltage
DC	Direct current
DDM	Data Driven Model
DNN	Deep Neural Network
DOD	Depth of Discharge
E	Open circuit voltage
ECM	Equivalent Circuit Model
EIS	Electrochemical Impedance Spectroscopy
EKF	Extended Kalman Filter
EM	Electro chemical Model
EMI	Electromagnetic interference
EOl	End of Life
ESSs	Energy Storage Systems
EVs	Electric Vehicles
FKF	Fading Kalman Filter
GHCE	Green House Gas Emission
GNL	General Non-Linear
GWh	Giga watt-hour
HEVs	Hybrid Electric Vehicles
I <sub>Batt</sub>	Battery current
I <sub>L</sub>	Output current of the battery
IoT	Internet of things
I <sub>pulse</sub>	Current Pulse
IR	Internal Resistance
KF	Kalman Filter
LIBs	Lithium-ion Batteries
Li-ion	Lithium ion
MCC	Multi-step C harging
NA/MCL2	Sodium/Metal Chloride
NiCd	Nickel Cadmium
Ni-MH	Nickel Metal Hydride
OCV	Open Circuit Voltage
PC	Pulse Charging
PCM	Phase-change material
PLL	Phased-locked loop
PNGV	Partnership for a New Generation of Vehicles
PWM	Pulse width modulation
Q	Quantity of electricity delivered by or supplied to the battery
Q <sub>0</sub>	Battery initial charge
Q <sub>c</sub>	Battery Actual capacity of a current battery
Q <sub>max</sub>	Maximum charge that can be stored in the battery
Q <sub>n</sub>	Battery Nominal capacity of a fresh battery
R <sub>0</sub> , R <sub>1</sub> , R <sub>2</sub> , R <sub>3</sub>	Equivalent Ohmic Resistance of the Cell
RC	Resistance-Capacitance
R <sub>p</sub> , R <sub>e</sub>	Equivalent internal resistance generated by the electrochemical polarization and concentration

TABLE 1. (Continued.) Nomenclature.

	polarization of the cell
RUL	Remaining useful life
SEI	Solid Electrolyte interface
SOA	Safe Operating Area
SOC	State of Charge
SOE	State of Energy
SOF	State of Function
SOH	State of Health
SOL	State of Life
SOP	State of Power
SVM	Support Vector Machine
TLBO	Teaching-learning-based optimization
UKF	Unscented Kalman Filter
U <sub>L</sub>	External voltage of the battery
V2H	Vehicle to home
V <sub>Batt</sub>	Battery voltage
VIEI	vehicular information and energy internet
W kg <sup>-1</sup>	Watt per kilo gram
Wh kg <sup>-1</sup>	Watt-hour per kilo gram
Wh L <sup>-1</sup>	Watt per kilo gram

with three primary categories: battery electric models, battery thermal models, and battery coupled models, as illustrated in Fig. 12.

A. BATTERY ELECTRIC MODEL

The models that need batteries include electrochemical models [23], [24], [25], [26], [27], equivalent circuit models [28], [29], [30], [31], [32], [33], [34], [35], [36], [37], [38], [39], [40], [41], [42], and data-driven models [43], [44], [45], [46], [47], [48], [49], [50], [51], [52], [53], [54], [55], [56], [57], [58], [59], [60], [61], [62], [63], [64].

1) ELECTROCHEMICAL MODEL (EM)

Electrochemical models describe battery behavior by utilizing partial differential equations that consider electrolyte concentration, electrode size, and electrochemical processes within the battery. While electrochemical models provide precise battery parameters, they require significant computational power and time to solve multiple equations pertaining to the battery current, temperature, electrolyte concentration, solid concentration, open circuit potential, over potential, and electrolyte potential, and more. Implementing them in real-time applications is challenging. Researchers have proposed various approaches to address these challenges. Doyle et al. [24] introduced a Pseudo-2-D (P2D) electrochemical model, however because there are so many nonlinear equations, it takes longer to simulate and It reduces the effectiveness of its computation for BMS applications. Domenico et al. [25] developed a reduced-order electrochemical model by instead of taking into account its dispersion throughout the electrodes, averaging the solid electrolyte concentration, enabling real-time implementation on board buses. However, parameter identification remains a difficult task. Ahmed et al. [26], [27] employed a SOC estimation and genetic algorithms are used to identify parameters, but

TABLE 2. Key details of batteries used in EV [1].

Battery Type	Nominal Voltage (V)	Power Density (W.kg <sup>-1</sup> )	Energy Density (W.h.kg <sup>-1</sup> )	Charging Efficiency (%)	life cycle	Self-Discharge rate (%.month <sup>-1</sup> )	Charging Temperature (°C)	Discharging Temperature (°C)
Li-ion	3.2-3.7	250-680	100-270	80-90	600-3000	3-10	0 to 45	-20 to 60
NiCd	1.2	150	50-80	70-90	1000	20	0 to 45	-20 to 65
Lead Acid	2.0	180	30-50	50-95	200-300	5	-20 to 50	-20 to 50
NiMH	1.2	250-1000	60-120	65	300-600	30	0 to 45	-20 to 65

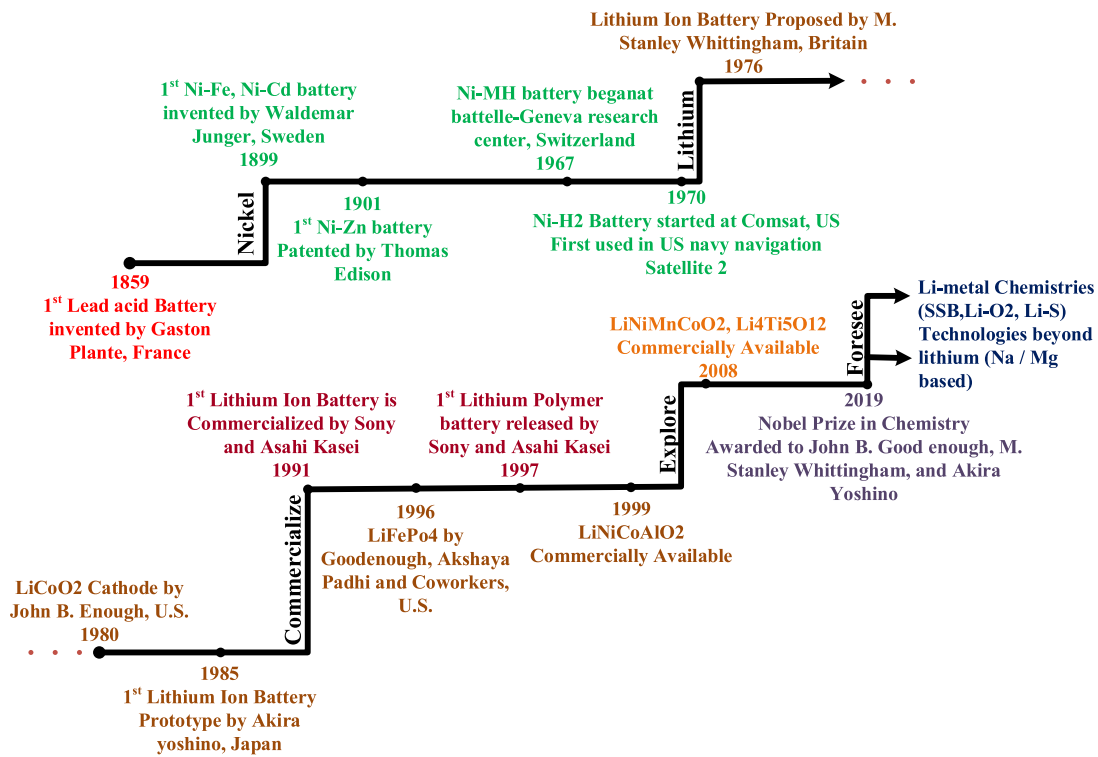

FIGURE 10. Milestones and foresight of battery Technologies.

the model’s accuracy is compromised due to assumptions made to reduce its order. Han et al. [28] provided a rough model that keeps track of the diffusion process and how electrolyte concentration is distributed inside the battery. Zou et al. [29] A reduced-order model based on singular perturbation and averaging theory was presented for Li-ion battery SOC estimation and discharging capacity forecasting. This model simplification approach is applicable to all battery types. However, building a high-fidelity model that takes into account age, capacity fading, and temperature increases complexity while also improving accuracy. Table 4 compares various electrochemical battery model types in a brief manner.

## 2) EQUIVALENT CIRCUIT MODEL (ECM)

The electrical activity of the battery is modeled by the ECM using electrical elements including voltage sources, resistors,

and capacitors. A high-value capacitor [25] or a regulated voltage source serves as ECM representation of the battery Open Circuit Voltage (OCV), a vital metric for state estimation approaches [26]. The Rint model, Thevenin model, PNGV model, and GNL-model are examples of analogous circuit models that are frequently employed, as illustrated in Fig. 13. The Rint model, which represents the battery as a voltage source with series resistance, is the simplest basic ECM [28]. However, this simple model is not capable of accurately capturing the specific characteristics of batteries used in EVs. To enhance the representation of battery dynamics, the Rint model is extended by incorporating a single Resistance-Capacitance (RC) parallel network, resulting in the widely used Thevenin model [29]. The dynamic behavior of batteries is well captured by the Thevenin model. The Partnership for a New Generation of Vehicles (PNGV) model, or FreedomCar model a modified variation of the Thevenin

**TABLE 3. Li-ion battery types [66].**

Battery Types	Cathode Material	Anode Material	Nominal Voltage (V)	Life Cycle	Energy Density (Wh.L <sup>-1</sup> )	Cost	Safety
Lithium Iron Phosphate (LiFePo4)	LiFePo4	Graphite	3.2	High	Low	High	Safest Li-ion cell Chemistry
Lithium Cobalt oxide (LiCoO2)	LiCoO2	Graphite	3.6	Medium	High	Low	Highest safety concern
Lithium Nickel Manganese Cobalt oxide (LiNiMnCoO2)	LiNiMnCoO2	Graphite	3.6	Medium	High	Medium	Good Safety
Lithium Manganese oxide (LiMnO2)	LiMnO2	Graphite	3.7	Low	Low	Medium	Good Safety
Lithium Nickel Cobalt Aluminum oxide (LiNiCoAlO2)	LiNiCoAlO2	Graphite	3.6	Medium	High	Medium	Safety Concern Required

**TABLE 4. Comparison of various electrochemical models of battery.**

S.No	Model	Merits	Demerits
1	Extended Single Particle (ESP) Model.	The electrode is reduced to a single active particle. PDEs are solved using the approximate solution method or curve fitting. Increases the effectiveness of computation.	The complexity of the model rises
2	Reduced order model or Single particle (SP) model	Simple model that reduces the electrode to a single particle and ignores the liquid phase.	The solid-phase Li-ion concentration in the SP model still requires the solution of radial-domain PDEs. Precision at high C rates is lacking.
3	P2D electrochemical model or Doyle-Fuller-Newman (DFN) Electrochemical battery model.	High accuracy	High Computational Complexity

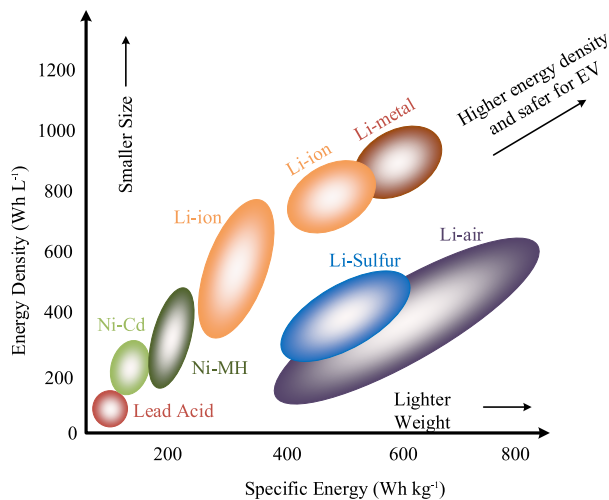

**FIGURE 11. Energy density and specific energy of various batteries at cell level.**

model, includes a fictive capacitor to account for variations in OCV [31], [32]. The PNGV model consists of OCV, polarization resistance, a capacitor, an imaginary capacitor, and an ohmic resistance [33]. While the PNGV model is

suitable for low SOC areas, it may not accurately represent high SOC regions. Resistance-Capacitance (RC) network-based models are among the several ECM models explored in the literature that have found widespread use for online applications.

These models include the one RC network ECM [34], [35], two RC network ECM [36], [37], [38], and three RC network ECM [39], [40]. Table 5 lists the model equations and parameters in accordance with circuit theory. The two RC network model is one of them. It is particularly notable for its high accuracy in predicting the relationship between input current and output voltage (I-V), as well as the charging and discharging times of the battery. Since batteries are nonlinear systems, their dynamics vary under different operating conditions such as SOC, temperature, and charging/discharging rates. Therefore, parameterizing the model becomes an “identification problem” or “optimization problem” to fit the model to measured data [41], [42]. The SOC, temperature, and charge-discharge rate of the battery must all be taken into account when updating the model parameters because the ECM circuit parts do not accurately reflect batteries physically.

TABLE 5. Models of various RC network-based equivalent circuits [23].

Circuit Diagram	Equations for Respective models	Specifiers
<p>One RC Network</p>	$V_{Batt} = OCV(SOC) - I_{Batt} * R_0 - V_1$ $V_1 = \left(\frac{Q}{C_1} + I_{Batt} * R_1\right) \exp\left(\frac{-1}{R_1 * C_1}\right) - I_{Batt} * R_1$	OCV, R <sub>0</sub> , R <sub>1</sub> , C <sub>1</sub>
<p>Two RC Network</p>	$V_{Batt} = OCV(SOC) - I_{Batt} * R_0 - V_1 - V_2$ $V_1 = \left(\frac{Q}{C_1} + I_{Batt} * R_1\right) \exp\left(\frac{-1}{R_1 * C_1}\right) - I_{Batt} * R_1$ $V_2 = \left(\frac{Q}{C_2} + I_{Batt} * R_2\right) \exp\left(\frac{-1}{R_2 * C_2}\right) - I_{Batt} * R_2$	OCV, R <sub>0</sub> , R <sub>1</sub> , C <sub>1</sub> , R <sub>2</sub> , C <sub>2</sub>
<p>Three RC Network</p>	$V_{Batt} = OCV(SOC) - I_{Batt} * R_0 - V_1 - V_2 - V_3$ $V_1 = \left(\frac{Q}{C_1} + I_{Batt} * R_1\right) \exp\left(\frac{-1}{R_1 * C_1}\right) - I_{Batt} * R_1$ $V_2 = \left(\frac{Q}{C_2} + I_{Batt} * R_2\right) \exp\left(\frac{-1}{R_2 * C_2}\right) - I_{Batt} * R_2$ $V_3 = \left(\frac{Q}{C_3} + I_{Batt} * R_3\right) \exp\left(\frac{-1}{R_3 * C_3}\right) - I_{Batt} * R_3$	OCV, R <sub>0</sub> , R <sub>1</sub> , C <sub>1</sub> , R <sub>2</sub> , C <sub>2</sub> , R <sub>3</sub> , C <sub>3</sub>

3) DATA DRIVEN MODEL (DDM)

Data-driven models (DDMs) offer a more efficient alternative to ECM and EM models, with the ability to approximate highly nonlinear battery characteristics. DDMs rely on data and computational intelligence to describe battery behavior, without the need for prior understanding of the battery internal structure. Various types of DDMs, such as Artificial Neural Network (ANN) [43], Adaptive Neuro-Fuzzy Inference Systems (ANFIS) [44], Deep Neural Network (DNN) [45], and Support Vector Machine (SVM) [46], [47], [48], have been employed for battery modeling, as shown in Fig. 20. DDMs have several advantages, particularly in situations where [49]:

1. The controlled system has no known global mathematical model.
2. Unknown is the controlled system entire global mathematical model.
3. Building a mathematical model to depict the controlled system with an undetermined structure while it is in operation is not practical.
4. The Regulated System’s Mechanism model has too many parameters, is overly complicated, or is difficult to study and create using conventional methods.

In these cases, a data-driven control approach, facilitated by DDMs, can provide significant benefits by accurately capturing the behavior of the system without relying on a known mathematical model as given in Table 6. Modeling batteries accurately is challenging using traditional methods like ECM and EIM internal chemical processes and hazy environmental operating conditions. Black-box models, on the other hand, offer benefits like parallel distributed processing, high computation rates, fault tolerance, and the capacity to adapt to deal with this complexity by utilizing the nonlinear connection of input data for training. Fuzzy systems’ subjectivity and flexibility are combined with neural networks’ capacity for learning in ANFIS [45]. The inherent multiple-model structure of the T-S fuzzy model allows it to manage the nonlinear dynamics of batteries. Black-box models, on the other hand, produce accurate results. Rule-based modeling, however, has accuracy that varies with the number of rules at the cost of increased computational complexity and limited interpretability. SVM, on the other hand, uses a small number of samples with the kernel trick to describe system dynamics [46].

Although SVM has a simpler design than ANN, it requires solving a Costly optimization in terms of computing problem

TABLE 6. Comparison of DDM of battery.

Ref	Model	Parameters	Training Algorithm / Optimizer	Activation Function	Merits	Demerits
Ben sassi et al., [52]	Feed Forward Neural Network (FFNN)	Hidden Neurons	Gradient descent	Hyperbolic tangent sigmoid activation function	It is easy to implement and doesn't require a lot of computational power or a protracted learning process.	The FFNN output is solely dependent on the input at hand, and because it is unable to accurately model temporal information, it cannot be used to solve time sequence problems like SOC estimate.
Hannan et al., [53]	Back Propagation Neural Network (BPNN)	Learning Rate, No. of Hidden Layers, No. of Neurons	Levenberg–Marquardt (LM) algorithm and back tracking Search algorithm (BSA)	Sigmoid	easy to use and adaptable	The universality and robustness are insufficient. Data overfitting, slow convergence, and vulnerability to local minima trapping.
Du et al., [59], Hossain Lipu et al., [60]	Extreme Learning Machine (ELM)	Hidden Neurons	Moore–Penrose generalized inverse operation	Sigmoid function	Good Generalization Performance, and fast learning. The model's parameters don't need to be adjusted during training.	Performance highly depends on training Accuracy.
Cui et al., [55]	Wavelet Neural Network (WNN)	Hidden neurons, Wavelet translation and dilation parameter	Levenberg Marquardt Weights	Morlet wavelet function	Easy learning	To improve accuracy, it is need to add more layers and neurons.
Nagulapati et al., [56], Deng et al., [57], Babaeiyaz di et al., [58]	Gaussian Process Regression (GPR)	Amplitude of Kernel function, length scale of the distance measure	Kernel Function	Squared exponential kernel function (RBF kernel)	Ability to adjust hyperparameter values using nonparametric modelling and probabilistic prediction	The size and diversity of the dataset have an impact on the model's accuracy.
Weng et al., [48]	Support Vector Regression (SVR)	Kernel function & regularization parameter	Logistic regression	Gaussian radial RBF kernel	Simple structure, computationally efficient prognostic algorithm	Less precise than GPR The training model is dependent on the relationship between the features in the training data and the target data.
Khumpro m et al.,[45]	DNN	Learning rate and momentum, dropout rate	Back-propagation stochastic gradient Descent	Relu Activation Function	Simple to execute, a respectable degree of generalisation, and precise outcomes for intricate Applications.	High computational time and more resources are required
Zhang et al., [54]	Radial Basis Function Neural Network (RBFNN)	Gauss Function Centre, Weights	Stochastic gradient	Radiated Gaussian kernel function	Global approximation, quick learning and training, and interpolation mastery	Slow-paced training
Wu et al.,[61]	Recurrent Neural Network (RNN)	-	Grid search and the adaptive moment estimation method	-	It can learn characteristics and time dependencies from sequential data using its internal state (memory).	Limitation in capturing the length of the data; Not suitable for long-term sequences due to exploding gradient

TABLE 6. (Continued.) Comparison of DDM of battery.

Hasan et al.,[62]	NARX	Hidden neurons and delay for input and Feedback. Time step, sampling interval, batch size, iteration, Weights and biases of network	Levenberg Marquardt	Sigmoid	Can model the temporal information (changes in input/output over time) in a given time series	Accuracy depends on no. of previous inputs and feedback outputs
Li et al.,[63]	GRU-RNN	Mini batch size, Learning rate, gradient Threshold, no. of nodes in the layer.	Back propagation through time (BPTT)	Sigmoid	Overcomes the issue of the short-term dependency of the simple RNN, more robust to Vanishing gradients,	The performance of GRU-RNN Increases with the hyper parameters such as time step and iteration as well as the training data size
Zhang et al.,[64] Yang et al.,[65]	LSTM-RNN		BPTT and Adaptive moment (ADAM) method.	Hyperbolic Tangent Function	Capture longer sequences of information without Gradients vanishing.	More training time and complex training process

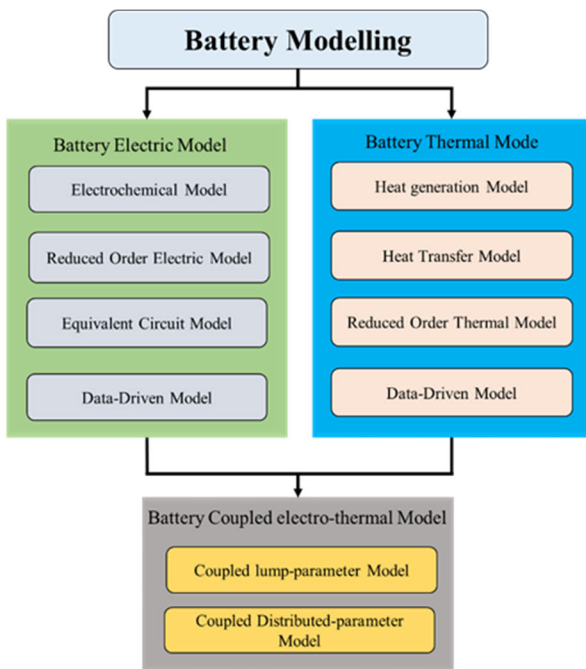

FIGURE 12. Types of battery modelling.

to determine kernel parameters. The RBF kernel is commonly used due to its strong generalization capability [50]. However, SVM struggles with handling large amounts of data, making SOC estimation and It might be difficult to estimate SOH for battery packs. SVM, ANN, DNN techniques use machine learning algorithms to forecast nonlinear parameters and estimate battery SOC based on statistical data. Among these, DNN outperforms ANN and SVM [45]. DDM necessitates intensive calculations for real-time understanding of battery properties by means of training and data-acquisition

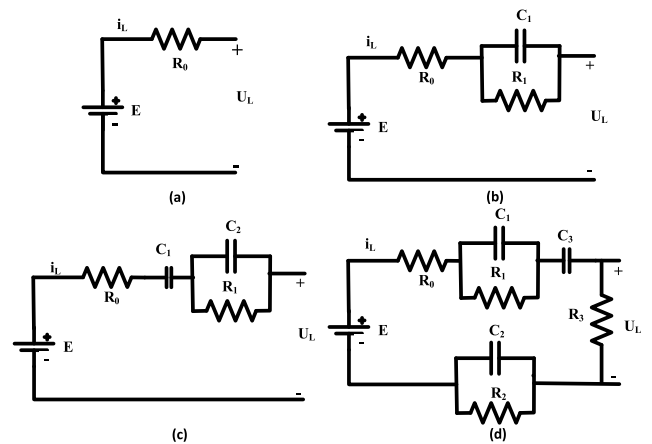

FIGURE 13. The following Li-ion battery models are: (a) Rint model (b) Thevenin model (c) PNGV model (d) GNL-model.

procedures. In all the aforementioned methods, data preprocessing and noise removal are essential. The computational complexity associated with DDMs can pose obstacles in economic applications. Data collection is vital for developing accurate DDMs, as these models require a large amount of training data. As batteries are increasingly deployed across various applications, their degradation rates vary under different operating conditions, necessitating application-specific data for accurate battery modeling [51]. To mitigate the time and cost associated with data collection, researchers can utilize publicly available data instead of conducting extensive experiments. To increase accuracy while lowering complexity, care should be taken when choosing the right model, model parameter type, and parameter identification procedure. Table 7 provides a performance comparison of different battery models, highlighting their strengths and weaknesses.

Overall, both accuracy and simplicity are critical considerations when selecting a battery model for BMS design.

### B. BATTERY THERMAL MODEL

Due to its large impact on battery performance and lifespan, thermal behavior, in particular temperature, is a vital component of EV BMS. To accurately represent the thermal behavior of batteries, a variety of models have been created, including heat transfer models, heat generation models, reduced-order thermal models, and data-driven models. The distribution of elements including activation, concentration, and ohmic losses, which vary within the battery, are taken into consideration by different methodologies used by heat production models to characterise heat generation in batteries. Abada et al. [67] presented a thermal model for the thermal management system of a Li-ion battery pack, based on the energy balance between heat generation and heat dissipation. The thermal model can be represented by the following equation:

$$\frac{d}{dt} Q_{accu} = \rho C_p \frac{\partial T}{\partial t} = \frac{d}{dt} Q_{gen} - \frac{d}{dt} Q_{dis} \quad (1)$$

In this equation  $\rho$ ,  $C_p$ ,  $t$ , and  $T$  are the cell density, heat capacity, time and cell temperature respectively. In addition,  $Q_{gen}$ ,  $Q_{accu}$ , and  $Q_{dis}$  are the accumulated heat, generated heat, and dissipated heat, respectively.  $Q_{gen}$  encompasses the heat produced by chemical reactions that is both reversible and irreversible.  $Q_{dis}$  includes heat-transferring processes like conduction, convection, and radiation. The electrochemical-thermal model and the electro-thermal model were developed on the basis of this thermal model as summarized in Table 8. [68], [69]. They take into account things like chemical processes, ion mobility in the solid electrolyte interphase (SEI), over potentiation at the reaction surface, Ohmic loss in electrodes, and entropy during charging and discharging when analyzing the thermal behaviour of batteries. Table 9 lists the symbols and characteristics related to the electrochemical-thermal model. The electrochemical-thermal model provides a comprehensive understanding of battery operation by considering both electrochemical and thermal aspects. However, one drawback of this model is its high computational burden, which arises from the large number of equations required to accurately predict battery temperature.

### C. BATTERY COUPLED ELECTRO-THERMAL MODEL

There have been several coupled electro-thermal models established to capture the strong coupling between battery electric and thermal behaviors. These models allow for the simultaneous consideration of battery electric parameters (e.g., voltage, current, SOC) and thermal parameters and behaviours Shown in Fig.14. (e.g., surface and internal temperature). There have been several developed linked electro-thermal models have been proposed in the literature to achieve this coupling [68], [69], [70]. For instance, Goutam et al. [71] established a three-dimensional

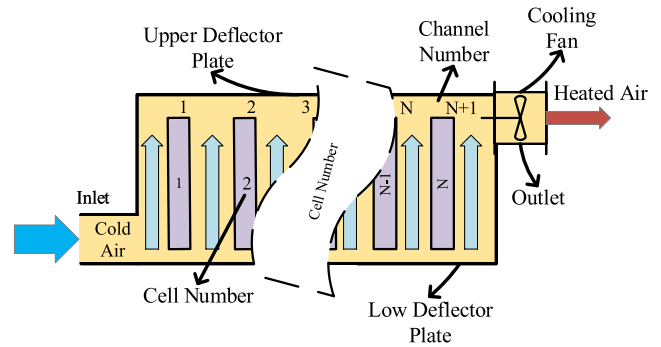

FIGURE 14. Schematic view of Li-ion battery pack.

electro-thermal model that determines heat generation and calculates battery SOC. A three-dimensional temperature distribution model plus a two-dimensional potential distribution model make up this model. By utilizing this coupled model, battery SOC and temperature distribution can be effectively determined under both constant and dynamic currents.

In another study [72], a Batteries with three distinct cathode materials were used to validate a simplified low-temperature electro-thermal model. This reduced model demonstrates sufficient accuracy and enables the development on Under low-temperature circumstances, quick heating and optimal charging techniques. Basu et al. [73] used a linked three-dimensional electro-thermal model to investigate the impacts of various battery operations, such as coolant flow rate and discharge current, on battery temperature. Through the analysis of this coupled model, it was observed that contact resistance plays a vital role in determining battery temperature.

In another study [72], a Batteries with three distinct cathode materials were used to validate a simplified low-temperature electro-thermal model. This reduced model demonstrates sufficient accuracy and enables the development on Under low-temperature circumstances, quick heating and optimal charging techniques. Basu et al. [73] used a linked three-dimensional electro-thermal model to investigate the impacts of various battery operations, such as coolant flow rate and discharge current, on battery temperature. Through the analysis of this coupled model, it was observed that contact resistance plays a vital role in determining battery temperature.

### V. STATE OF CHARGE

Battery charging requires careful consideration and effective measures to ensure a smooth and efficient process. The SOC is a crucial factor in battery operation, representing the level of charge relative to the battery capacity as shown in Fig. 15. comparable to a fuel gauge in a gasoline-powered car, SOC indicates the remaining amount of energy in a battery to power an EVs. Various critical performance aspects, such as range and fuel economy, heavily depend on SOC. SOC is typically expressed as a percentage (0% = empty;

TABLE 7. Comparison of various battery models.

S.No	Model	Merits	Demerits
1	EM	High accuracy, fully explains the battery electrochemical reaction	Model complexity, high computational power requirements, and unsuitability for online control tasks
2	ECM	Simple model, real-time implementation	Lacking information about a battery intrinsic features, inferior to other models in accuracy
3	DDM	High nonlinear prediction capability, simplicity of implementation, and applicability for online applications	Large computational complexity, accuracy completely dependent on training data quality, and high storage requirements

TABLE 8. Comparison of electrochemical-thermal model and the electro-thermal model.

Item	Electrochemical-thermal model [70]	Electro-thermal model [71]
Heat Generation	Over-potential at the reaction surface: $q_{rxn} = \frac{V_{ca}}{V_{batt}} \frac{RT}{\epsilon_{ca}^2 F^2 \sqrt{k_c k_a (C_{s,max} - C_s) C_s}} I^2$	Reversible heat: $q_{rev} = IT \frac{\partial U}{\partial T}$
	Ohmic loss in the electrode: $q_{ohm} = \frac{\epsilon_{elec} V_{elec}}{V_{batt}} \frac{1}{A^2 \sigma_{eff}} I^2$	Irreversible heat: $q_{irrev} = I(U - V) = I^2 R$
	Ion transport in the SEI and electrolyte: $q_{trans} = \frac{I^2}{\sigma_{SEI} A^2} + \frac{\epsilon_{sp} V_{sp}}{V_{batt}} \frac{I^2}{A^2 K(2+t)}$	
	Entropy: $q_{rev} = \frac{V_{ca}}{V_{batt}} ai \cdot T \frac{\partial U}{\partial T}$	Total heat generation: $q_{gen} = I(U - V) - IT \frac{\partial U}{\partial T}$
	Irreversible heat: $q_{irrev} = \frac{I^2}{\sigma_{eq} A^2} + \frac{I}{\epsilon_{ca} V_{batt}} T \frac{\partial U}{\partial T}$	
Total heat generation: $q_{gen} = q_{rxn} + q_{ohm} + q_{tran} + q_{rev}$		
Heat Dissipation	Conduction: $Q_{cond} = -kA \frac{dT}{dx,y,z}$	
	Convection: $Q_{conv} = hA (T_{surface} - T_{environment})$	
	Radiation: $Q_{rad} = \epsilon A \sigma (T_{hot}^4 - T_{cold}^4)$ (neglect in common temperature regions for commercial battery)	

100% = full) and is commonly used to define a battery current status while it is in operation.

$$SOC\% = 100 \times \frac{(Q_0 + Q)}{Q_{max}} \quad (2)$$

The SOC calculation can be performed using Equation (2), where  $Q_0$  (mAh) is the battery initial charge.  $Q$  (mAh) is the quantity of electricity delivered by or supplied to the battery. it is negative during the discharge and positive during the charge.  $Q_{max}$  (mAh) is the maximum charge that can be stored in the battery. The determination of battery SOC is a fundamental aspect of BMS. Accurate and reliable SOC estimation is crucial for vehicle energy management and the optimal design of control systems. To achieve real-time SOC estimation, numerous methods have been proposed. To provide a more detailed comparison of these methods, they can be categorized into four groups, as illustrated in Fig. 16.

Battery SOC estimate is an essential component of battery management systems, and fusion models and algorithms may

greatly improve SOC prediction accuracy by merging data from many sources. Here are a few fusion models and methods that are frequently employed for estimating battery SOC:

- Extended Kalman Filter (EKF): The EKF is a Kalman filter modification created to handle nonlinear systems. By integrating voltage and current data with a battery model that accounts for the nonlinear relationship between SOC and battery voltage, it is frequently used to estimate battery SOC.
- Particle Filter (PF): Both nonlinearities and uncertainties are handled by PFs. They operate by converting the SOC into particles and changing their weights in accordance with voltage and current readings. When dealing with complicated battery behavior and shifting operating circumstances, PFs are very helpful.
- Recursive Least Squares (RLS) with Adaptive Gain: RLS algorithms can use voltage and current observations to estimate battery characteristics and SOC in an



**TABLE 9. Electrochemical thermal model parameters and symbols.**

Symbol	Parameter
$V_{ca}$	Volume of cathode
$V_{batt}$	Volume of battery
$V_{elec}$	Volume of anode
$V_{sp}$	Volume of separator
$\epsilon_{ca}$	Porosity of cathode
$\epsilon_{elec}$	Porosity of anode
$\epsilon_{sp}$	Porosity of separator
$k_c$	Kinetic constant of cathode
$k_a$	Kinetic constant of anode
$A$	Area
$\sigma_{eff}$	Effective electrical conductivity
$\sigma_{SEI}$	Solid phase conductivity
$\sigma_{eq}$	Equivalent conductivity
$C_s$	Concentration of intercalated Li
$k$	Ionic conductivity
$a$	Specific area
$i$	Current density
$F$	Faraday constant

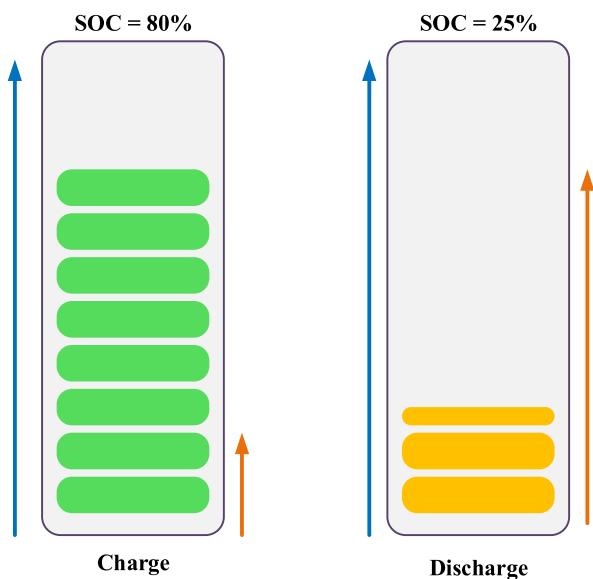

**FIGURE 15. Charging and discharging process of battery.**

adaptive manner. RLS is capable of coping with fluctuations in battery behavior by gradually modifying the estimate gain.

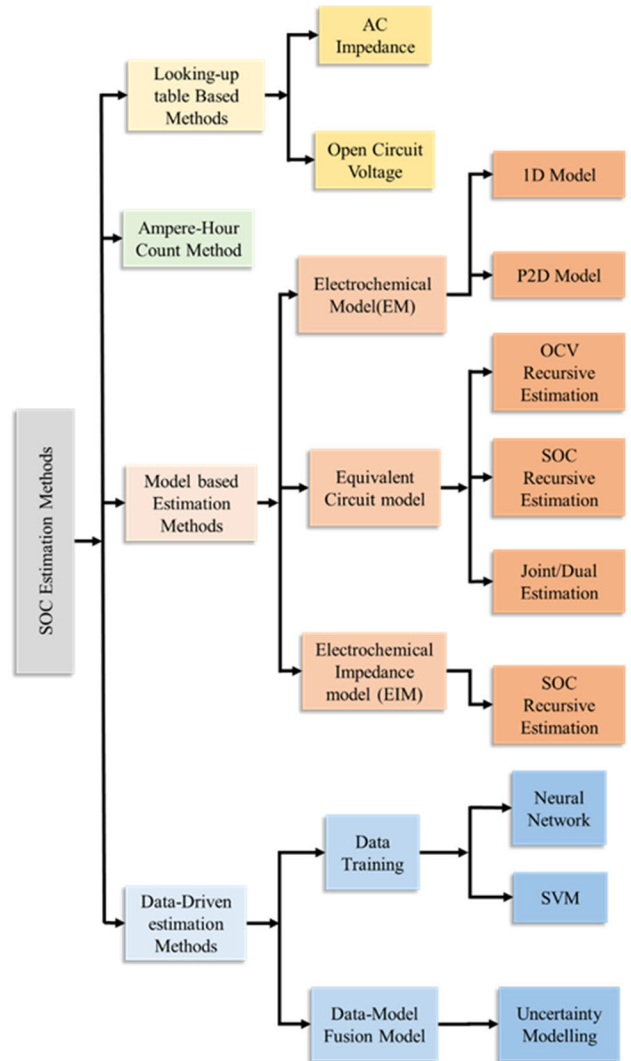

**FIGURE 16. Classification of the SOC estimation methods.**

- **Model-Based Adaptive Filters:** These filters use adaptive algorithms to combine a battery model with in-the-moment data, modifying the model’s parameters to reflect actual battery performance. The accuracy of the long-term SOC estimate is improved by this method.
- **Neural Networks and Deep Learning:** Current and voltage data can be combined over time using recurrent neural networks (RNNs) and long short-term memory (LSTM) networks to calculate SOC. These networks are capable of complicated connection learning and battery condition adaptation.
- **Multiple Model Estimation (MME):** Each battery model or estimating technique that MME combines is suited for a particular set of operating conditions. Based on the present operational condition, the most suitable model is chosen.
- **Unscented Kalman Filter (UKF):** The UKF is an EKF substitute that employs a deterministic sampling method to capture the real statistical moments of the battery

model's nonlinearities. Compared to the EKF, it can offer a more precise SOC estimation.

- **Fuzzy Logic:** Fuzzy logic enables nonlinearity and uncertainty to be included into SOC estimate. In order to provide an accurate SOC estimate, it can integrate voltage, current, temperature, and other sensor information.
- **Ensemble Methods:** Ensemble approaches can deliver a more reliable and accurate SOC calculation by merging different estimating techniques, such as EKF, UKF, and neural networks, especially when dealing with shifting operating circumstances.
- **Hybrid Approaches:** In order to accurately estimate SOC, hybrid models integrate physics-based and data-driven methodologies, utilizing both battery models and real-time observations.

The selection of a fusion model or algorithm is influenced by a number of variables, including the precision of the available measurements, the complexity of the battery's behavior, available computing power, and the required level of accuracy. Battery SOC estimate may be made more accurate and trustworthy by information fusion, which is crucial for the dependable and safe functioning of battery systems.

#### A. LOOKUP TABLE BASED METHOD

The SOC of batteries has a direct correlation with their extrinsic identifying characteristics, such as impedance and OCV. The relationship between SOC and OCV has been plotted in Fig. 17. Therefore, by measuring these parameters and utilizing a look-up table that establishes the relationships between SOC and one or more parameters, to estimate the SOC of batteries [74], [75]. For example, the SOC of the battery can be determined by the knowledge of OCV. This approach is commonly used in battery management technologies for SOC estimation. However, obtaining precise real-time measurements of OCV is challenging because it requires disconnecting the power source and allowing the battery to rest for an extended period. Additionally, measurement relying on battery impedance on specific measurement devices, making it impractical for use in operating EVs. Instead, impedance measurement is more suitable for laboratory environments where accurate and controlled testing can be conducted.

#### B. AMPERE-HOUR INTEGRAL METHOD

By directly measuring the battery voltage and current, the SOC can be determined. One commonly used method is the Ampere-hour (Ah) method, which estimates the battery state by integrating the charging and discharging currents. This method is straightforward and computationally efficient [76]. However, there are some challenges associated with the Ah method in Dynamic applications. Accurately measuring the initial SOC is challenging, because SOC estimation is constrained by things like the battery unknown beginning capacity, its self-discharge rate, and the reduction in battery capacity. Typically, Peukert's impact and coulombic

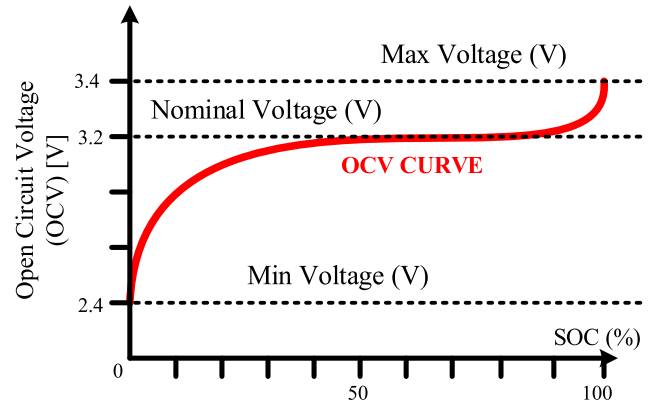

FIGURE 17. LiFePo4 OCV-SOC relationship.

efficiency are taken into consideration in the estimation performed using the Ah technique. The equation to calculate battery SOC using the Ampere-hour method is presented in Eq. (3)

$$SOC(k) = SOC(k_0) + \frac{\int_{k_0}^k \eta I(t) dt}{C_n} \quad (3)$$

where,  $\eta$  stands for the efficiency of battery charging or discharging,  $SOC(k_0)$  is known initial SOC,  $I(t)$  is the current value which is positive for charging and negative for discharging,  $C_n$  stands for the battery nominal capacity. The Ah method has several drawbacks that need to be addressed.

Firstly, it has to be aware of the battery initial SOC, which may not always be readily available. Secondly, there are inherent measurement errors in the battery current because to sporadic disruptions like noise and temperature drift, which can affect the accuracy of the SOC estimation. Lastly, the value of  $Q$ , which represents the capacity of the battery, may need to be recalibrated due to variations in the battery age and operating circumstances. When all of these conditions are present, the Ah method's accuracy may suffer. Therefore, it is more suitable to use the Ah method in conjunction with other supporting techniques, such as model-based methods, to increase the SOC estimation's precision and dependability.

#### C. MODEL BASED ESTIMATION METHODS

The Model-Based Estimation methods for SOC can be broadly classified into three types: Electrochemical method (EM), Equivalent Circuit Model (ECM), and Electrochemical Impedance Model (EIM). These methods involve expressing battery models as nonlinear state equations and utilizing state estimation algorithms and adaptive filters to infer the internal state of the batteries. Various algorithms, such as Kalman Filter (KF) [77], [78], [79], Extended Kalman Filter (EKF) [80], [81], [82], [83], Unscented Kalman Filter (UKF) [84], [85], [86], [87], [88], Fading Kalman Filter (FKF) [89], Cubature Kalman Filter [90], [91], [92], Particle Filter [93],  $H_\infty$  observer method [94], [95], Adaptive Extended Kalman Filter (AEKF) [96], [97], [98], and Adaptive Unscented Kalman Filter (AUKF) [99], [100], [101], [102], are commonly employed in these methods. The general

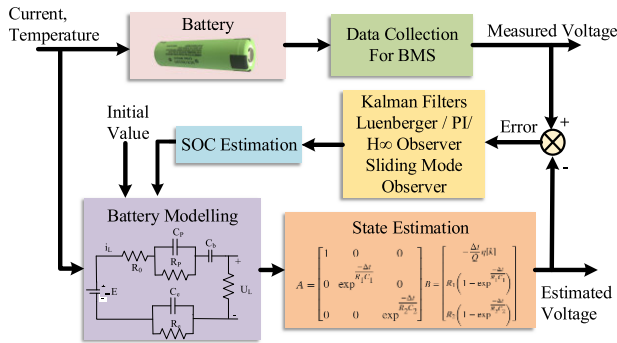

**FIGURE 18.** A general Block Diagram of model based SOC estimation method.

block diagram of the model based SOC estimation method is shown in Fig. 18.

Kalman Filter is an optimal estimator widely used for linear systems. KF for nonlinear systems necessitates intricate computations. Plett developed the EKF approach specifically for nonlinear battery model SOC estimation. Although EKF addresses nonlinearities, it suffers from linearization errors and increased computational effort and the flowchart of EKF method is shown in Fig.19. UKF, on the other hand, can provide accurate results for highly nonlinear models by eliminating linearization errors. However, it involves Cholesky factorizations and sigma point selection, which impact performance. EKF incorporates a fading concept to correct modeling errors but demands more computational power. Filter parameters like noise covariance matrices significantly influence estimation accuracy and convergence rate. KF algorithms struggle with non-Gaussian noises. Accurate estimate is achieved by the development of AUKF algorithms, which automatically update noise covariance matrices. However, they come with increased computational time and complexity. The  $H_\infty$  observer method is another suitable approach but shares similar issues as KF-based methods, including dependence on gain for accuracy and convergence rate. KF algorithms possess self-correcting capabilities, making them suitable for estimating the situation of quickly shifting systems with accurate models. However, challenges persist, such as handling initial SOC errors. Therefore, KF algorithms should be employed alongside other techniques to enhance estimation accuracy and reliability in practical applications.

#### D. DATA-DRIVEN BASED ESTIMATION METHODS

The black-box model method is an effective approach for solving nonlinear problems in battery modeling and state estimation, providing high prediction accuracy. The Data-Driven Model, explained in detail in Section. IV, utilizes methods for modeling nonlinear statistical data that are practical for capturing complex relationships and patterns in the data [91]. For instance, neural networks have been employed to develop SOC estimators, with inputs including current, temperature, battery SOC, and voltage as the output layer. This method has demonstrated high computational accuracy.

Various algorithms can be utilized for black-box modeling, such as fuzzy controllers [92], [93], support vector machines [94], [95], neural networks [96], [97], [98], [99], [100], [101], [102], [103], [104], [105], [106], and combinations thereof [111]. These algorithms, however, are quite sensitive to the parameters, and incorrect parameter selection may lead to non-convergence if the training data does not adequately cover the operating conditions. ANNs [99], [100], [101], [102], [103], [104] have gained popularity for validating complex nonlinear models due to their self-learning capabilities. Although ANNs heavily rely on training with collective information, they offer computational efficiency at a lower cost. However, overlearning poses a challenge with ANN models. A summary of SOC estimation using different combinations of methods is provided in Table 10 and Table 11. It is clear from the table that the Ah method is Simple and It is clear from the table that inexpensive, but unsuited to real-time applications. Adaptive filter and observer methods offer high accuracy and are suitable for real-time applications, but they suffer from computational complexity, configuration effort, and implementation challenges. Data-Driven Model (DDM) complexity, making them suitable for real-time applications with lower computational complexity. The block diagram of the DDM is shown in Fig.20. However, successful implementation of DDM methods requires appropriate model selection, hyper parameter tuning algorithms, proper training algorithms, and extensive data collection and normalization.

#### E. SOC ESTIMATION FOR BATTERY PACK

The use of battery packs, consisting of multiple connected cells, introduces challenges in accurately estimating the SOC due to variations in individual cell performance and non-uniform characteristics within the pack [109]. While the capacity and SOC of a single cell can be measured through discharge testing, these measurements are not directly applicable to battery packs. The complexity, time-varying, nonlinear, and non-uniform properties of battery packs make it challenging to assess capacity and SOC accurately. By calculating the SOC of a battery pack, one can determine the internal condition of a complicated hybrid-connected battery system. Accurate SOC estimates for battery packs have been sought after, and these efforts can be categorized into three types:

##### 1) CELL CALCULATION BASED METHODS

The “Big cell” method determines the SOC by treating the battery pack as a single cell and using the voltage and current of the pack. However, this method overlooks the inconsistencies in cell performance, compromising the safety of the battery pack. The “Short board effect” method uses the extreme cell (with the lowest or highest voltage) to estimate the SOC of the battery pack. While this method improves safety, it reduces energy utilization within the desired operating range of the battery pack (30% - 80% SOC). The “One by one” calculation approach determines the SOC

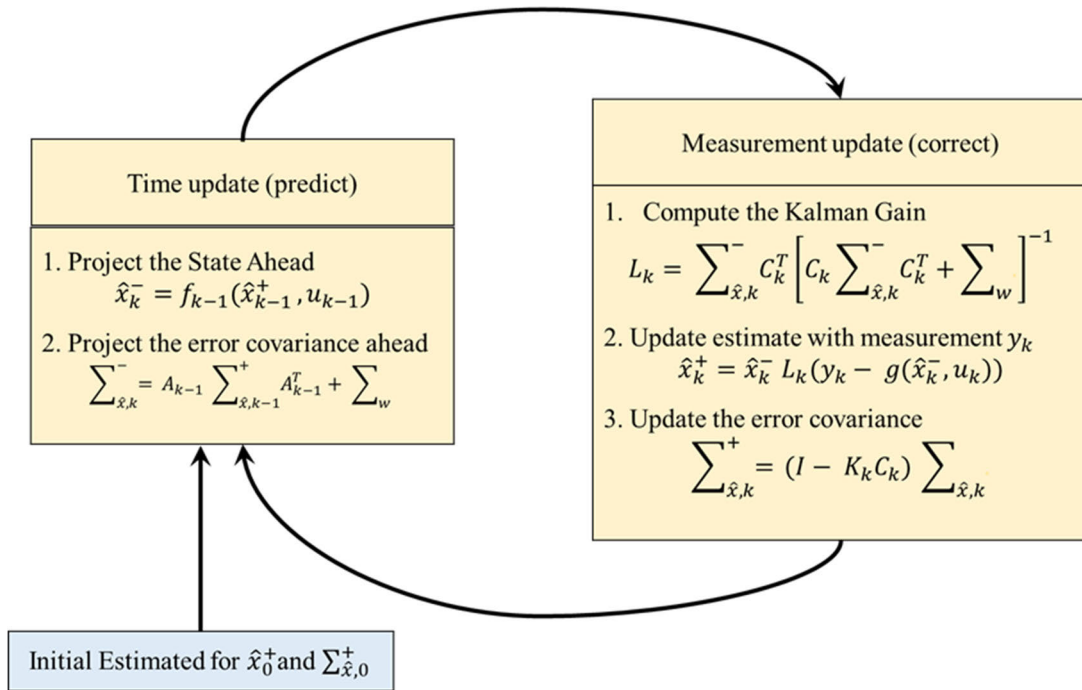

FIGURE 19. Flow diagram of EKF.

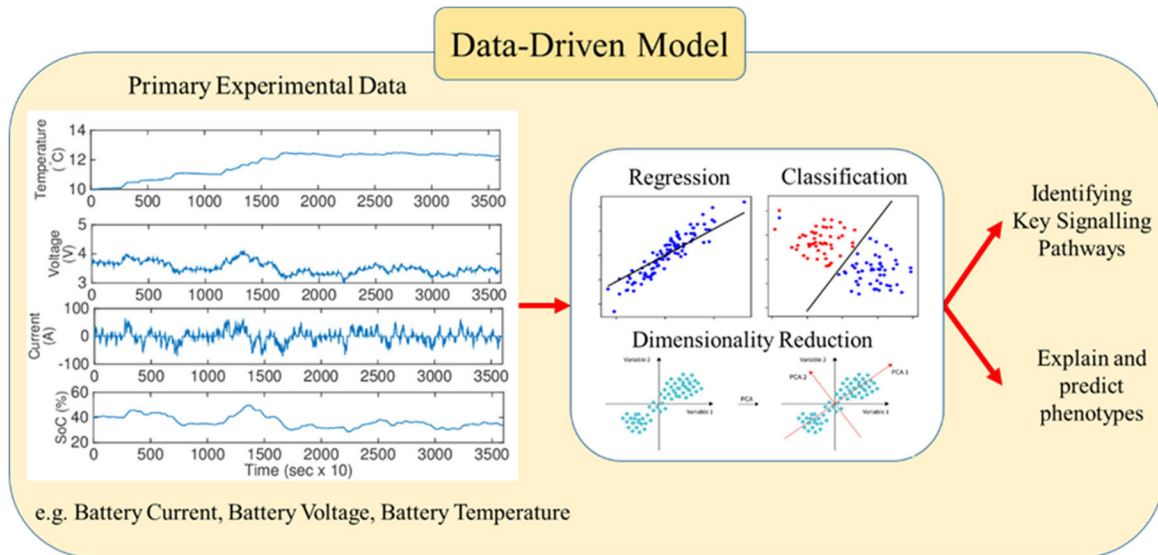

FIGURE 20. Data-driven model [237], [238].

for each individual cell before calculating the battery pack’s total SOC. Although this method offers accurate estimations, it incurs high computational costs and is unfit for real-time applications in electric cars. The flowchart of the cell filtering method is shown in Fig. 21.

2) SCREENING PROCESS BASED METHODS

These methods involve selecting battery cells with similar characteristics (capacity, resistance, etc.) building a battery

pack. Due to the pack’s good consistency, the SOC of a single cell is then utilized to represent the SOC of the complete battery pack. A second-level screening process can be employed to select suitable cells for packaging the battery pack, ensuring better consistency among the cells.

3) BIAS CORRECTION METHODS

In this procedure, a notional model of the battery pack is constructed before a bias-correction technique is used to

TABLE 10. SOC estimation using neural network.

Author	Algorithm Execution	Remarks	Challenges
Xu <i>et al.</i> [108]	Fractional order ECM + Dual KF, Dual EKF, Adaptive dual KF + Recursive Least Square (RLS), Mixed swarm based Cooperative Particle Swarm Optimization (MCPSO)	Reduces current measurement error and battery model error using DEKF	To estimate the single-cell SOC, three techniques are used: EKF, KF, and Ah. Initial Parameters are determined by MCPSO in offline mode, and then RLS updates them. A method that is too difficult to implement at the pack level and is extremely complex
Yang <i>et al.</i> [109]	2RC-ECM-split battery model + AEKF	Cross interference between RC voltages and SOC is minimised by separating the model. As a result, convergence rate is raised.	The only consideration for model parameters is as an invariant function of SOC. ignoring the impact of ageing and temperature.
Ben Sassi <i>et al.</i> [52]	1RC-ECM + Non-linear Recursive LS + UKF	There has been comparison. UKF provides adequate accuracy and is appropriate for online estimate.	A complicated process, In order to select noisy covariance matrices, parameters are not changed, specified sample locations are necessary, and statistical knowledge is required.
Xie <i>et al.</i> [110]	1RC-ECM + EKF, Multi Model EKF (MMEKF), Adaptive fading EKF (AFEKF) + Multiple linear regression (MLR)	battery packs' estimated SOC. Different noise starting values are utilised in MMEKF for various models. The forgetting factor is added to AFEKF to limit EKF's use of memory.	Only offline parameters are recognised, and those related to SOC, age, and temperature are not updated. Choosing noisy covariance matrices requires statistical expertise. With switching approach, three algorithms are employed.
Xue <i>et al.</i> [111]	1RC-ECM + linear Interpolation + H $\infty$ observer	Handle the parameters' uncertainty. Analysis is done on the impact of parameter correction.	The OCV-SOC curve controls accuracy and convergence speed, and an optimization process is required to adjustment coefficient that establishes the observer gain matrix.
Samadi <i>et al.</i> [101]	EM + state-space + T-S Luenberger and H $\infty$ observer + T-S fuzzy model + Recursive LS	The observer's stability and robustness are discussed. Better than H's observer is T-S Luenberger.	Making rules requires more expertise.
Fotouhi <i>et al.</i> [34]	1RC-ECM + ANFIS + Prediction-Error Minimization (PEM) algorithm	At each time step, parameters are recognised and modified. To determine the connection between OCV and SOC, ANFIS is used.	Need additional time for the open-loop approach.
Boujoudar <i>et al.</i> [43]	DDM (NARX) + BPNN + FFNN	Model developed without understanding battery chemistry	Training and data collecting are essential for accuracy. An optimization strategy is required when deciding on the number of hidden layers and neurons per layer. Error results from ANN overlearning.
Yang <i>et al.</i> [65]	DDM (LSTM-RNN) + UKF	primarily concentrates on the relationship between temperature and OCV SOC and its effect on estimating battery SOC.	More memory and high complexity are needed. require pre-determined sampling locations.

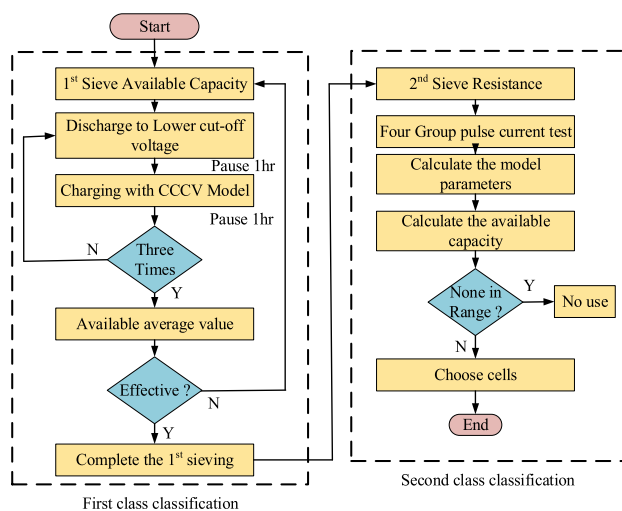

FIGURE 21. Cell filtering approach Procedure.

determine the discrepancies between the nominal model and the actual battery cells. The revised model is used to do the SOC estimation, which determines the SOC of the battery pack by calculating the SOC of each individual cell. [110].

Cell SOC, discharge/charge rate, and the maximum achievable capacity differential between the cell and the average value of the battery pack are all functions of the uncertainty factor in the equation.

$$U_t^j = U_{oc} - U_{D1} - \dots - U_{Dn} - i_L R_i + \delta \left( C_{rate}^j, z^j, \Delta Q^j \right) \quad (4)$$

where  $\Delta Q^j$  between cell  $j$  and average value of battery pack, uncertainty  $\delta$  is the function of cell,  $-z^j$ , maximum available capacity difference, discharge/charge rate  $-C_{rate}^j$ , cell SOC. the  $j$  is denote the cell number in battery pack. This method reduces computational costs and improves real-time performance. It shows promise for SOC estimation in With their time-varying, nonlinear, and uneven features, battery packs. However, if the number of battery cells in an electric vehicle is large, Costs associated with computing must be significantly reduced. In summary, accurately estimating the SOC of battery packs is challenging due to variations in cell performance and non-uniform characteristics within the pack. Different methods, such as cell calculation, screening processes, and bias correction, have been proposed to

TABLE 11. SOC estimation at different combinations.

Author	Technique	Outcomes	Challenges
Electric vehicle Li-ion battery SOC Estimations [102]	ANN	<ul style="list-style-type: none"> <li>Utilizing nonlinearity</li> <li>Close outcomes are attained.</li> </ul>	Temperature variations affect training data
State of charge estimation [103]	ANN	<ul style="list-style-type: none"> <li>Accurate state of charge estimation is possible with ANN.</li> <li>Battery dynamics can be self-learned by ANN</li> </ul>	<ul style="list-style-type: none"> <li>the price of purchasing battery-powered systems.</li> <li>pricier components</li> </ul>
SOC estimation of Li-ion battery using convolutional neural network with U-Net architecture [104]	U-Net	<ul style="list-style-type: none"> <li>Online real-time implementation.</li> <li>Accurate SOC values</li> <li>Relative SOC prediction is dropped</li> </ul>	To fit any particular application, a trade-off between accuracy and computation time is required.
A New Lithium Polymer Battery Dataset with Different Discharge Levels: SOC Estimation of Lithium Polymer Batteries with Different Convolutional Neural Network Models [105]	CNN	<ul style="list-style-type: none"> <li>accurate convergence that happens quickly</li> <li>may be used with a variety of rechargeable batteries.</li> </ul>	<ul style="list-style-type: none"> <li>It is necessary to measure each cell's current and voltage.</li> <li>The trained NN might no longer offer good results when the battery ages. .</li> </ul>
Estimating State of Charge for xEV Batteries Using 1D Convolutional Neural Networks and Transfer Learning [106]	1D CNN	<ul style="list-style-type: none"> <li>a mean squared error under 1e-6</li> <li>The precision of the proposed model is quite important.</li> <li>utilises cutting-edge machine learning tools</li> <li>easy to use</li> </ul>	<ul style="list-style-type: none"> <li>limited range</li> <li>The car is not in a regulated environment, nor is its traction battery.</li> </ul>
A probabilistic neural network (PNN) is used to estimate the SOH of Li-ion batteries [107]	PNN	<ul style="list-style-type: none"> <li>For medium-sized datasets, extremely quick</li> <li>This technique can help with battery SOC estimation. .</li> </ul>	<ul style="list-style-type: none"> <li>Multilayer perceptron networks outperform them in the classification of fresh cases.</li> <li>For the purpose of storing the model, PNNs require additional memory.</li> </ul>

address this issue, each with its own advantages and considerations in terms of computational cost, accuracy, and real-time applicability.

VI. STATE OF HEALTH

It is crucial to distinguish between two ideas: battery health state and remaining useful life prediction. The battery cycle life is the maximum number of cycles a battery can withstand given its kind, construction, and the manufacturer’s recommended usage. The SOH compares the health and performance of a used battery to a brand new battery of the same type [209]. SOH is determined by calculating the ratio of the current actual capacity  $Q_C$  of the battery to its nominal capacity  $Q_n$ , as shown in Equation 5.

$$SOH = Q_C / Q_n \tag{5}$$

SOH is a subjective metric that has been defined differently by many studies by taking into account various quantitative battery performance metrics, including current, resistance, voltage, self-discharge rate, temperature, stress, and strain. Although SOH depends on these parameters, it is a compares a used battery performance and health to those of a brand-new battery of the same type. Temperature also plays a significant role in battery performance as shown in Fig. 23, where the cycle life of a cell is optimal when The operating temperature is kept between 15°C and 45°C. When the temperature falls

below a certain level, the cycle life gradually goes below 15°C or exceeds 45°C. Further temperature increase leads to a sharp decrease in cycle life due to thermal runaway [210], [211], [212].

SOH estimation does not have a fixed definition, and each battery manufacturer establishes their own criteria. A number of battery properties, including capacity and internal resistance, can be used to compute SOH. However, rather than being a precise measurement, it is an evaluation and judgement. Some factors that determine how well Li-ion batteries perform over time include the phase shift of the electrode material, electrode dynamic performance, electrolyte breakdown state, and the creation of SEI films [210], [211], [212]. Battery aging is characterized by irreversible changes in electrolyte characteristics, anode and cathode properties, and alterations in battery component structures as shown in Fig. 22. Aging can be categorized as cycle aging, due to periods of battery use and calendar aging that take place while batteries are stored. Changes in capacity, internal resistance, and power fade are indicators of aging and are closely related to the estimation of SOH [214]. The choice of the most suitable parameter for SOH estimation depends on the specific circumstances and the changes observed in the external actions of the battery, such as a reduction in rated capacity or an increase in temperature brought on by internal modifications like corrosion the relationship between

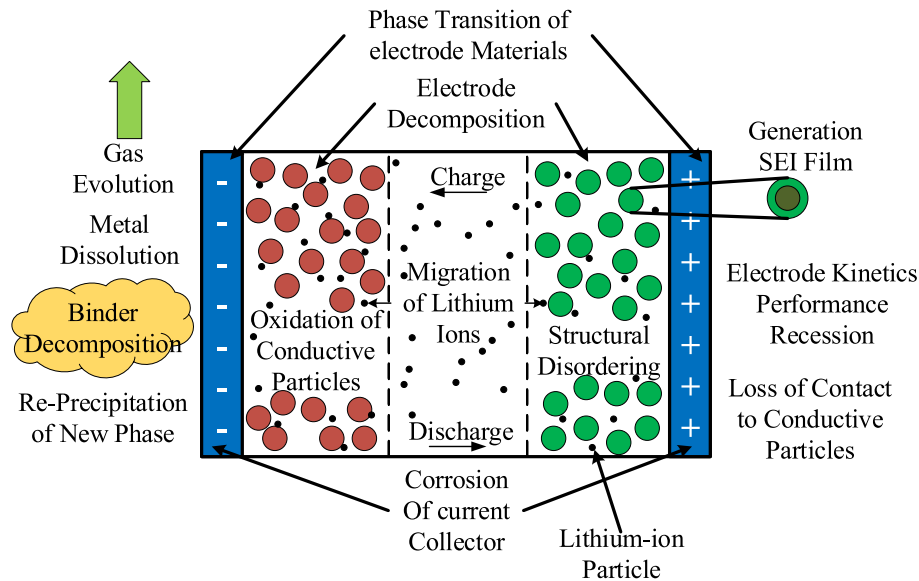

FIGURE 22. Lithium-ion battery aging.

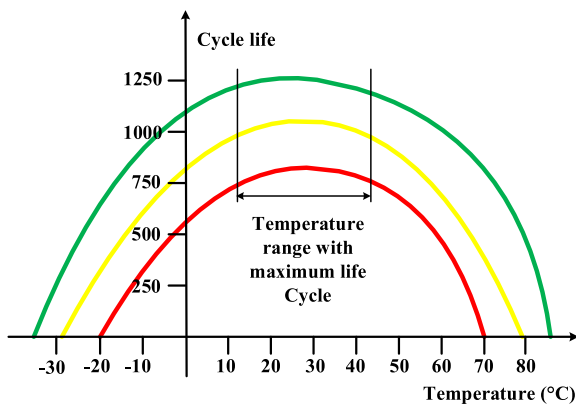

FIGURE 23. Li-ion battery lifecycle vs °C diagram.

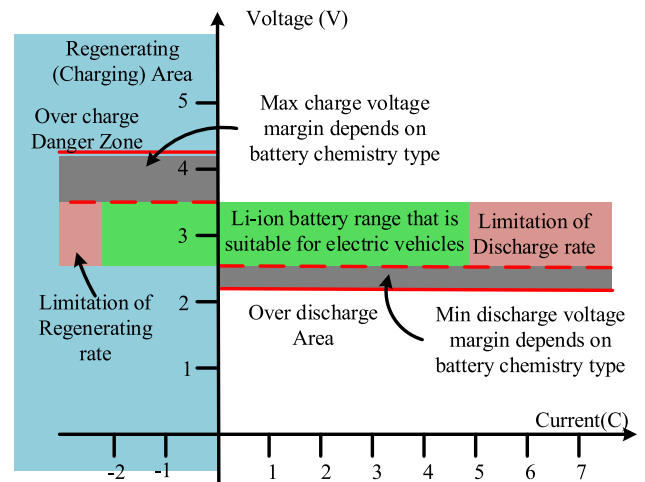
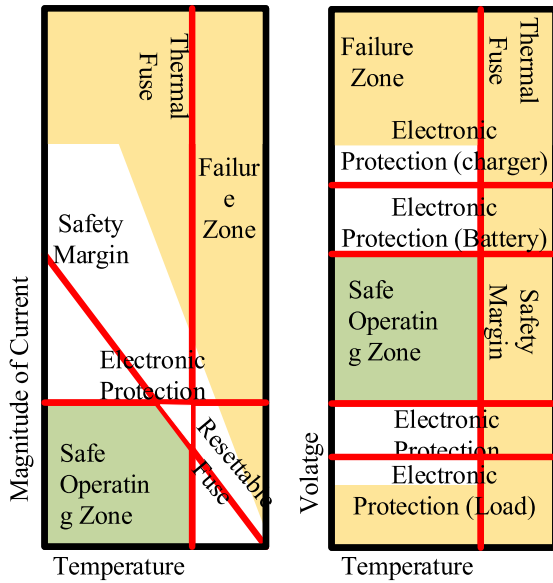

FIGURE 24. Li-ion battery lifecycle vs temperature diagram.

cycle life and cell operating temperature, highlighting the optimal range between 15°C and 45°C. Operating below 15°C or above 45°C gradually decreases cycle life, while further temperature increases lead to a sharp decline due to thermal runaway as shown in Fig. 23. Fig. 24 illustrates the Li-ion batteries typically function within a certain current and voltage range. According to the battery nominal capacity, the x-axis shows the current (C-rate), while the y-axis represents the voltage (V). Positive current values indicate the discharge process, while negative current values correspond to charging or regenerative processes.

Critical thresholds, depicted as gray zones, are defined based on the specific Li-ion battery type [215]. When the voltage rises over the maximum defined charging voltage or falls below the stated cut-off discharge voltage, these thresholds prohibit overcharging and over-discharging, respectively. Operating within the acceptable voltage range is crucial for battery longevity, as any overcharge or Overcharging

can hasten deterioration and reduce battery life. The battery degradation rate, nevertheless, varies depending on the rate of charge or discharge, which is impacted by stress factors, and it is not constant within the permissible range. The discharge rate is dynamic and directly influenced by operating conditions such as route slope, vehicle weight, speed, and acceleration. A threshold is frequently established by EV designers to restrict the maximum discharge current rate. The charge rate is fairly stable during the charging procedure. Though it can speed up battery charging, a higher pace may also shorten battery life [216]. Therefore, designers strive to strike a balance between the charging rate and its impact on battery life, which influences the available charging rate in charging stations (e.g., level 1 and level 2) [217]. The BMS regulates the charging rate to ensure optimal charging. The process of charging batteries is further temperature-sensitive.



**FIGURE 25.** (a) Current-temperature SOA zone, (b) voltage temperature SOA zone.

Operate within the safe operating area (SOA) advised by the manufacturer to ensure battery safety [218].

The SOA may need to be adjusted based on battery aging and environmental conditions, as battery function deteriorates due to factors like resistance and capacity degradation, as shown in Fig. 25.

Furthermore, predicting the highest possible instantaneous power capacity becomes important as ESSs are utilized to meet higher power demands. As a battery state indicator, State of Function (SOF) is utilized to determine the maximal instantaneous output capability and guarantee operating within the SOA [219]. Causes, impacts, and outcomes of the drop in li-ion batteries with respect to health and battery life is given in Table 12 Various approaches are employed for battery state estimation, which can be categorized into three main methods, as shown in Fig. 26. Internal resistance, impedance, and capacity are the three basic parameters used to estimate battery SOH. While internal resistance and impedance show the battery ability to deliver power, capacity displays how much energy it can hold. In contrast to EVs, where battery energy is more important, power capability is of higher significance in hybrid applications. Due to ageing factors, these signs vary over the battery lifespan. By comparing the actual indicator value (capacity, impedance, or resistance) with its original value, SOH can be computed. Two different approaches, experimental and adaptive methods, can be used to predict these changes. Experimental methods involve storing the using battery cycling data history and newly acquired knowledge to determine SOH. By considering the impact of key parameters on battery lifespan, it becomes possible to estimate the SOH of the battery. This estimation process necessitates a thorough understanding of the relationship between battery cell operation and degradation, which can be obtained through physical analysis or by evaluating extensive datasets that combine operation history and SOH testing of

the battery cell. Such insights enable a more accurate estimation of SOH and contribute to the overall understanding of battery performance and longevity. Various SOH estimation methods are given in Figure 26.

**A. ESTIMATION EXPERIMENTAL METHODS**

**1) MEASUREMENT OF BATTERY INTERNAL RESISTANCE**

A battery internal resistance, which controls the voltage drop during current flow, is a key factor in determining its SOH. This parameter is significantly affected by aging and degradation, with an increase in value indicating a decrease in battery SOH. Consequently, the internal resistance is frequently utilized as a robust indicator for estimating battery SOH. Several researchers have investigated techniques to measure this internal resistance, with the most prevalent method known as current pulse [220], [221]. This method applies Ohm’s Law by measuring the voltage drop across the battery for a specified current and then employs the following formula [222]:

$$R_b (SOC, T) = \frac{OCV (SOC, T) - V_{bat}(SOC, T)}{I_{pulse}} \quad (6)$$

where  $R_b$  represents the internal resistance of the battery, OCV the open circuit voltage,  $V_{bat}$  the voltage, and  $I_{pulse}$  the current applied. This technique is frequently used in laboratories to accurately describe the internal resistance behaviour of batteries under various operating situations. This method is better suited for stationary and laboratory applications due to its time-consuming nature, which necessitates allowing the battery to relax and attain equilibrium first, which takes around an hour.

**2) BATTERY INTERNAL IMPEDANCE MEASUREMENT**

An indication of battery SOH is known to be a battery internal impedance, which includes both internal resistance and reactance. It has been observed and substantiated that a battery internal impedance tends to rise with time, making it a valuable SOH indicator. The most commonly employed method for measuring impedance is Electrochemical Impedance Spectroscopy (EIS) [223], [224]. EIS is a non-destructive method that determines an electrical system’s impedance by running a sinusoidal AC current through it and gauging the voltage response. The impedance is measured across a range of frequencies. One notable advantage of this method is its ability to accurately identify the aging phenomena occurring within the battery. In a specific study [225], the author employed EIS to investigate two key aging phenomena in batteries: the movement of lithium ions through the Charge transport at the positive electrode and the SEI layer.

**3) BATTERY ENERGY LEVEL**

The fundamental aspect of capacity shows the total energy storage capacity of a battery. With aging, this capacity is known to decrease. Therefore, one of the most reliable techniques for calculating the battery SOH is by experimentally



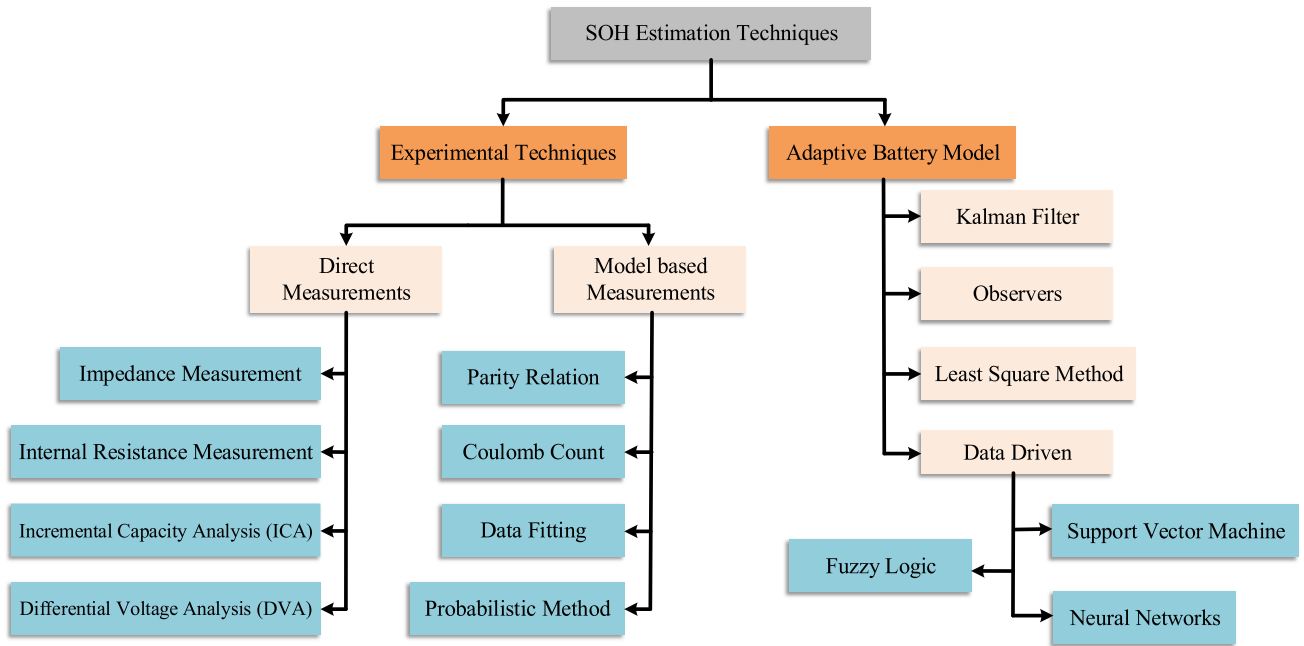

FIGURE 26. Various SOH estimation methods.

TABLE 12. Causes, impacts, and outcomes of the drop in Li-ion batteries.

Recession Reason	Influence	Consequence
Changing phases of electrode materials	Changes in internal stress and crystal distortion.	The capacity decreases
Recession's electrode kinetics performance	It was challenging to carry out the reactions of inactivation and disembodyment.	Internal resistance rises, decreasing capacity
The electrolyte's breakdown	Gas overflow and a reduction reaction	The capacity decreases
SEI film Generation	Deactivation and lithium-ion battery depletion	There is a drop in power and capacity.

measuring the fading capacity over time. In a study conducted by the author [226], multiple charging/discharging cycles were performed on a Li-ion battery until it reached its End of Life (EoL). The objective was to examine the relationship between the battery charging capacity and its voltage at different levels of degradation (cycle numbers). Another study [227] focused on estimating battery capacity through experimental testing conducted under varying temperature conditions, ranging from 25°C to 40°C, with the battery subjected to 800 cycles. The offline data obtained from The development of an online SOH estimate method was then done through experimentation. The battery is tested up to its EoL using these experimental procedures, but it should be emphasized that they can only be used offline in lab circumstances.

**B. MODEL BASED METHODS**

**1) DATA FITTING**

Resistance measurement is a valuable data acquisition method for estimating the SOH of a battery. To achieve a detailed fitting of internal resistance (IR), a characteristic map is proposed, which calculates the IR at various SOC

levels and temperatures. The utilization of a data map is necessary for accurate long-term predictions and because the calculation of a reliable IR value may require some time. However, a drawback of this approach is that each map needs to be parameterized for individual cell references. In [40], Using the idea of a severity factor map, a strategy based on a weighted ampere-hour throughput model of the battery is introduced. Within this framework, the investigation focuses on two primary factors that contribute to battery life reduction: DOD and temperature.

**2) COULOMB COUNTING**

Another commonly used technique for estimating SOH is Ah method. This method entails keeping note of the number of Ah that are charged or discharged as the battery is being charged or discharged. The battery's remaining capacity can be calculated by tracking the transferred Ah [229]. The estimation of SOH is calculated using Equation (7), the measured capacity  $Q_{nom}$  and the maximum available capacity  $Q_{max}$ .

$$SOH = \frac{Q_{max}}{Q_{nom}} \tag{7}$$

However, the Ah counting method has some drawbacks. It requires a high capacity for storing the counted Ah, which can be time-consuming. Additionally, the method is sensitive to precision due to the accumulation of errors over time. The coulomb counting method is still popular due to its simplicity, despite these drawbacks and its minimal dependency on other parameters such as Depth of Discharge (DOD), temperature or C-rate which often have a stronger impact on other estimation methods.

### 3) PARITY-RELATION METHOD

This method is used to assess and compare the effectiveness of batteries, allowing for the assessment of their desired functionality, as demonstrated in [230]. This method involves analyzing the battery dynamics during cranking using a battery model. The analysis reveals that the residual integrates information about the State of Health (SOH) provided by both battery resistance and voltage loss, thus improving diagnostic and prognostic capabilities. To observe the battery ohmic behaviour and voltage loss during engine cranking, significant real-world car cranking data was analysed., which serves as the basis for developing the battery model. Subsequently, The development of an integrated battery SOH monitoring technique based on parity relations. The parity relation is intended to describe how well-functioning batteries behave during engine cranking, allowing for a comprehensive evaluation of the battery performance and its SOH.

### 4) PROBABILISTIC METHOD

Probabilistic algorithms are utilized in certain methods to estimate the SOH of batteries. In [231], An integrated battery SOH monitoring technique based on parity relations is created. The parity relation is intended to describe the behaviour of batteries that are in good condition. This technique, which is based on classical probability theory, works by estimating the likelihood that the same voltage value would be observed more than once along the discharge curves of fresh and used batteries. Two peaks can be seen by calculating this likelihood, which shows the battery's propensity to age. The peak's elevation reflects the frequency of measurements with the same voltage value in a row. An algorithm is then employed to estimate the capacity by contrasting the volume of data with an identical voltage value. Using a generated look-up table, the algorithm can estimate the capacity of the battery cell based on partial charge or discharge tests. One significant Benefit of this method is the time saved through the use of partial charge and discharge tests. Additionally, the algorithm is designed to be straightforward and can be implemented within a BMS, making it easily applicable in practical scenarios.

## C. ADAPTIVE MODEL BASED METHODS

### 1) KALMAN FILTERS

An adaptive filtering approach commonly used for estimating battery SOH is the application of Kalman filters. As discussed

in detail in Section. V, Kalman filters have been employed in [232] for battery state and parameter estimation. Specifically, the battery internal resistance is estimated, allowing for accurate prediction of the SOH.

### 2) OBSERVER

In order to estimate SOH, observers have also been used as an adaptive identification technique. A sliding mode observer is used in [233] to calculate the SOH and SOC of a Li-ion battery. The technique exhibits good accuracy and resistance to modelling error and temperature changes.

### 3) LEAST SQUARE-BASED FILTERS

Another widely used approach in adaptive filtering is the use of Least Square-based algorithms, as discussed in [234] and [235]. RLS algorithms, in particular, have gained attention due to their simple implementation and accuracy. These algorithms allow accurate estimation of battery metrics that are directly related to battery states, like the internal resistance for SOH and the OCV for SOC. The identification process and state estimation are investigated in [236], emphasizing the importance of the battery model. Furthermore, an improved RLS-based algorithm called Multi Adaptive Forgetting Factors RLS (MAFFRLS) is presented in [235], which optimizes the forgetting factor through Particle Swarm Optimization (PSO) for enhanced parameter estimation accuracy.

### 4) DATA DRIVEN MODEL

As discussed in Section.V, data-driven models are also utilized for battery SOH estimation. In [237], Support Vector Regression (SVR) is employed to estimate the Remaining RUL of the battery. The estimated RUL is then considered in the energy management strategy of a Fuel Cell Hybrid EVs. The prognostic process is conducted on-board the vehicle using laboratory-measured data. Additionally, an improved Neural Network algorithm based on an innovative single-layer feed-forward Neural Network is presented in [238], [257], and [258]. This algorithm outperforms traditional Back-Propagation Neural Network (BPNN) in terms of operational speed and estimation accuracy. However, it requires a substantial amount of training data under various operating conditions. The merits and demerits of these methods are given in Table 13, Table 14, Table 15 and Table 16.

## VII. CHARGING AND DISCHARGING OF A BATTERY

When a battery's energy is depleted, its terminal voltage falls below the cut-off voltage, or its SOC reaches 20% or less the process of discharging it should end. At that point, the battery needs to be recharged. The charging performance of different battery types is provided in Table 17. It is crucial to avoid incorrect operations such as excessive-discharging, excessive-charging, or improper charging, as these can significantly accelerate battery degradation. While Li-ion batteries generally exhibit stable performance, they have a limited cycle life under high-temperature conditions and should

**TABLE 13. Experimental based methods.**

Methods	Merits	Demerits
KF methods	<ul style="list-style-type: none"> <li>• Error bounds</li> <li>• Accurate</li> <li>• Commonly used in the literature</li> </ul>	<ul style="list-style-type: none"> <li>• For nonlinear system, only the enhanced variants (EKF, UKF) of this filter are valid.</li> <li>• The more advanced versions need a lot of computational work and are rather sophisticated.</li> <li>• High-performance controller is necessary</li> </ul>
Least square-based methods	<ul style="list-style-type: none"> <li>• Precise</li> <li>• Simple Structure</li> <li>• Robust</li> </ul>	<ul style="list-style-type: none"> <li>• depends on the model used in terms of accuracy</li> <li>• Require a high performances controller</li> </ul>
Observers	<ul style="list-style-type: none"> <li>• Accurate</li> <li>• Robust</li> </ul>	<ul style="list-style-type: none"> <li>• need a controller with good performance</li> <li>• Greater computational expense compared to adaptive filters</li> </ul>

**TABLE 14. Adaptive model based methods.**

Methods	Merits	Demerits
Support Vector Regression	<ul style="list-style-type: none"> <li>• Non Parametric</li> <li>• Robust</li> <li>• Accurate.</li> </ul>	Strongly rely on the standard, variety, and volume of training data used
Fuzzy Logic	<ul style="list-style-type: none"> <li>• Accurate</li> <li>• Robust</li> <li>• Applicable to Non Linear system</li> </ul>	Depend significantly on the calibre, variety, and volume of the training data used
Neural Networks	<ul style="list-style-type: none"> <li>• Accurate</li> <li>• Less data is needed than with fuzzy.</li> </ul>	Depend significantly on the calibre, variety, and volume of the training data used

**TABLE 15. Data-driven model based methods methods.**

Methods	Merits	Demerits
Experimental-Based Methods	<ul style="list-style-type: none"> <li>• High Accuracy</li> <li>• High computational efficiency</li> </ul>	<ul style="list-style-type: none"> <li>• Requiring particular equipment to be used</li> <li>• The measurements typically take a long time.</li> </ul>
Model-Based Methods	<ul style="list-style-type: none"> <li>• Not need of Complex structure.</li> <li>• Give a reliable estimate that is largely accurate. .</li> <li>• Fast processing and simple implementation are provided.</li> </ul>	<ul style="list-style-type: none"> <li>• In the process development phase, demand experimental pre-validation. .</li> <li>• rely greatly on the model's precision and computational efficiency.</li> </ul>
Machine Learning Methods	<ul style="list-style-type: none"> <li>• Give a really accurate estimate. .</li> <li>• Make the implementation procedure simple.</li> </ul>	<ul style="list-style-type: none"> <li>• substantially on the accuracy of the training data utilised, as well as the battery kinds and operation environments taken into account.</li> <li>• Rely on the model's accuracy and computational efficiency</li> </ul>

not be charged below freezing temperatures. By accurately estimating battery SOC, SOH appropriate charging strategies can be developed to effectively charge the battery from its initial state to the desired SOC target. These charging techniques also help to prevent overheating, lengthen battery life, and increase overall capacity use. Various types of batteries and its charging methods are given in Table 18.

**A. TRADITIONAL BATTERY CHARGING APPROACH**

Various battery charging methods have been employed, including Constant Current Charging (CC), Multi-Step Constant Current Charging (MCC), Constant Voltage Charging

(CV), Boost Charging (BC), Constant Current Constant Voltage Charging (CCCV), Constant Trickle Charging (CTC) and Pulse Charging (PC) as shown in Fig. 27. The constant trickle charging method is a straightforward and affordable approach, ensuring safety during the charging process. However, it has the drawback of being time-consuming, requiring over 10 hours to fully charge the battery, which has led to it being referred to as an ‘Overnight Charger’ [117].

In order to minimize charging duration, the Constant CC method has been implemented. By increasing the charging current, faster charging times can be achieved. However, this approach requires additional control circuitry to accurately

**TABLE 16. Qualitative comparison of the SOH estimation methods.**

Approach	Benifits	Drawback
CTC	Simple method and Low cost Charging	Too long charging time
CC	Fast Charging	Increased capacity loss reduces battery life.
CV	Simple Charging	High internal temperature is produced in the cell battery deteriorates
CCCV	Computationally efficient and easy to implement	Slower charging in CV mode results in longer charging times.
MCC	Cuts down on charging time increases a battery lifespan	Difficult to find charging points at each step
BC-CCCV	Fast Charging	Charge first, then discharge Not appropriate for EV
PC	Fast and efficient charging	Picking the right charging pulses is challenging
S-PC	Medium level charging	Only low impedance can reach optimal frequency, which raises current, causes high temperatures, and reduces battery life.

**TABLE 17. Charging performance of various batteries.**

Approach	Benifits	Drawback
CTC	Simple method and Low cost Charging	Too long charging time
CC	Fast Charging	Increased capacity loss reduces battery life. High internal temperature is produced in the cell battery deteriorates
CV	Simple Charging	High internal temperature is produced in the cell battery deteriorates
CCCV	Computationally efficient and easy to implement	Slower charging in CV mode results in longer charging times.
MCC	Cuts down on charging time increases a battery lifespan	Difficult to find charging points at each step
BC-CCCV	Fast Charging	Charge first, then discharge Not appropriate for EV
PC	Fast and efficient charging	Picking the right charging pulses is challenging
S-PC	Medium level charging	Only low impedance can reach optimal frequency, which raises current, causes high temperatures, and reduces battery life.

identify the charging status, and when the battery is fully charged, stop the charging process. It's important to note that higher charging currents can lead to capacity loss and reduced battery lifespan because they have a detrimental impact on the ion concentration between the electrodes. On the other hand, CV charging involves initially providing current to the battery to reach its nominal voltage, followed by supplying the necessary current to maintain a constant voltage at that level. The accuracy of setting this voltage is crucial, as high voltage levels can decrease the battery lifespan, while low voltage settings may result in incomplete charging. Additionally, rapid changes in current during CV charging can lead to increased temperature. To address these considerations, the CCCV charging method has been introduced, combining

**TABLE 18. Various battery types and its charging performance.**

Battery Type	Charging Performance
Li-ion	<ul style="list-style-type: none"> <li>• However, harm to battery lifetime can occur while charging at very low temperatures, much below zero.</li> <li>• High temperatures can accelerate charging.</li> </ul>
Lead acid	<ul style="list-style-type: none"> <li>• Higher temperature results in a 3 mV/°C</li> <li>• Reduction in the V-threshold while charging at or below -0.3 °C.</li> </ul>
NiMH, NiCd	<ul style="list-style-type: none"> <li>• At 60 °C, charging acceptance falls from 70 percent to 45 percent.</li> <li>• charging at a rate of 0.1 C between -17 and 0 °C</li> <li>• charging at 0.3 C between 0 and 6 °C</li> </ul>

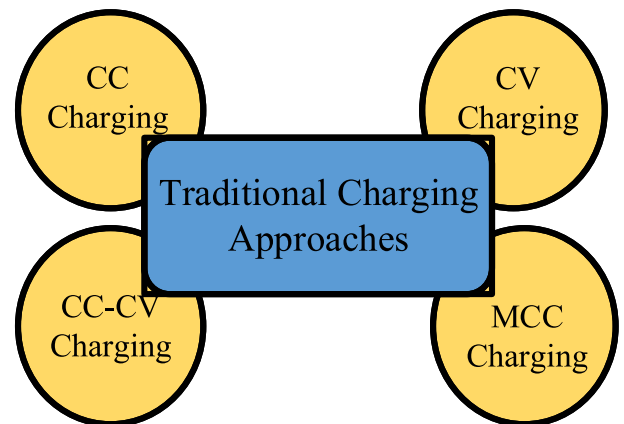

**FIGURE 27. Traditional charging approaches for battery.**

elements of both CC and CV charging. It has become the preferred and widely used method for fast charging Li-ion batteries [118]. Under the CCCV method, the charging

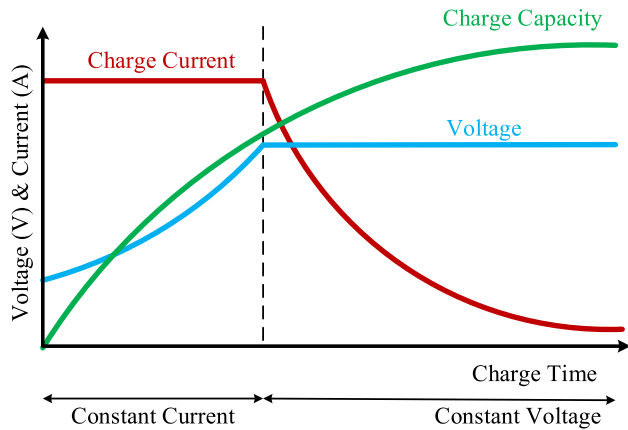

FIGURE 28. CC-CV charging approach.

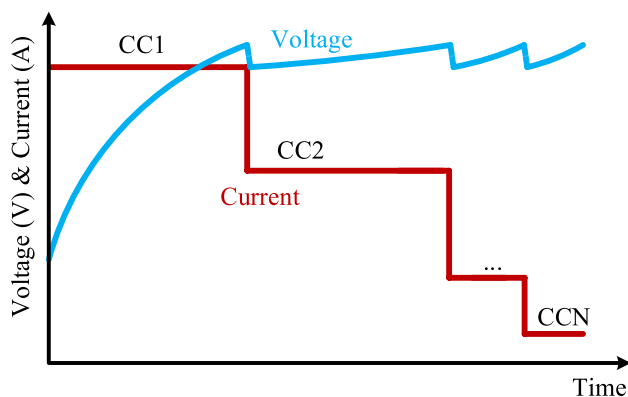

FIGURE 29. MCC charging approach.

process begins in the CC mode, when the battery is fed a continuous current until the terminal voltage approaches the nominal value as shown in Fig. 28.

Then, the charging mode switches to CV, where a constant voltage is applied until the battery current reaches its lower limit. However, it's worth noting that the CV mode prolongs the overall charging time, typically taking approximately three times longer than the CC mode. This extended duration is a trade-off for ensuring proper charging and avoiding potential issues. To reduce charging time and manage temperature rise, the MCC method has been developed. However, one challenge with this approach is determining the appropriate constant current value for each charging step, which can be problematic.

To address the challenges associated with the MCC charging method, various soft computing algorithms have been employed as shown in Fig. 29 to determine optimal values for each charging step. Algorithms such as the ant-colony algorithm [119], Taguchi method [120], genetic algorithm [124], [125], particle swarm optimization [121], [122], [123], dynamic programming algorithm [126], and multi-objective biogeography-based optimization [127], [128] have been utilized for this purpose. These algorithms help optimize the charging process and minimize capacity loss caused

by electrolyte decomposition during switching at different current rates. To further improve charging efficiency and reduce charging time, the MCCC method [129], [130] has been introduced. To prevent capacity loss and guarantee full charge, it combines brief intervals of constant voltage charging with the MCC technique. BC is another recommended method for reducing charging time. It involves applying a high voltage to the battery for a short duration (5 to 10 minutes) known as the boost period. The battery receives a substantial quantity of charge quickly during this boost time. Afterward, the standard CCCV approach is employed with a lower constant current value. However, it's important to note that BC requires the battery to be fully discharged before starting the charging process, making it less suitable for real-time applications in electric vehicles. PC is a validated method for fast and efficient charging. However, one drawback of PC is the challenge of selecting the correct charge pulse [131], [132]. Instead of using a square wave, a modified version of PC makes use of a sinusoidal wave. In order to maximize the charging current, both types of PC techniques require a charging frequency that is optimal. Table.16 provides a summary of the advantages and disadvantages of these charging methods.

## B. OPTIMIZATION OF BATTERY CHARGING APPROACH

Fast charging of Li-ion batteries presents a challenge for electric vehicle manufacturers, as it leads to rapid temperature increases and accelerated battery degradation. Therefore, the development of optimal charging strategies has become crucial in addressing these issues in EV applications. The initial state of charge, charge and discharge current rates, temperature rise, depth of discharge, cycle times, charging strategy, overcharge, over-discharge, and more have a significant impact on the Li-ion battery charge curve. Consequently, there are multiple constraints to consider when developing an optimal charging strategy, such as charging duration, temperature increase, current flow, energy loss, charging effectiveness, level of charge, condition of health, charging voltage threshold, capacity and power fade, ageing impacts, capacity utilisation, and impedance increase. Fig. 30 provides an illustration of some constraints involved in developing an optimal charging strategy.

### 1) CCCV CHARGING OPTIMIZATION

One approach to optimize Li-ion battery charging is the CCCV method. Numerous studies have focused on improving the CC-CV charging approach. For instance, in [133], an optimised using a cycle control algorithm with a zero computational approach, producing precise and smooth charging. Reference [134] presents a closed-form approach that utilizes a cost function considering charging time, energy loss, and temperature rise to search for the optimal charging strategy for Li-ion batteries. Reference [135] introduces a controller that enhances Li-ion battery performance by replacing the general CV mode with two modes: Sense

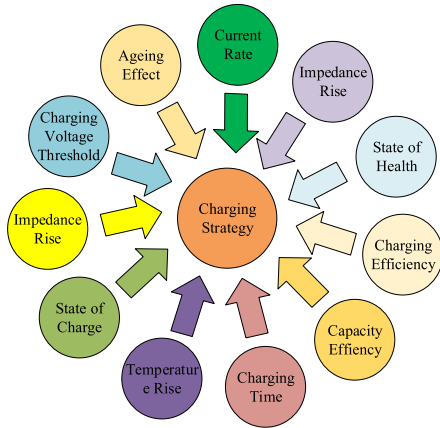

FIGURE 30. Limitations for creating the best charging plan.

and charge, enabling faster charging trajectories. Reference [136] introduces a battery charging cost function that considers temperature increase, particularly inside the battery, energy loss, and charging time. These competing goals are balanced using the teaching-learning-based optimization (TLBO) method to get the ideal CC-CV pattern. In [127], a model-based strategy using multi-objective biogeography-based optimization (M-BBO) is proposed to optimize the CC-CV charging pattern for Li-ion battery management. With specified current regions to effectively balance these goals, this method enables appropriate trade-offs between charging speed, energy conversion efficiency, and temperature variance. Reference [138] demonstrates a user-cell aware charging method that increases the capacity of a charged Li-ion battery. This strategy extends the standard CC-CV approach, starting with CC charging until a predefined voltage is reached, followed by charging, until the current reaches the cutoff threshold, a different predetermined voltage will be used. The use of phase-locked loop (PLL) control [139] improves the performance of CC-CV charging. Additionally, [140] introduces a current-pumped battery charger (CPBC) based on PLL CC-CV to enhance Li-ion battery charging performance, resulting in improved battery capacity and efficiency. Overall, these research efforts aim to develop optimized CC-CV charging strategies for Li-ion batteries, taking into account elements like battery capacity use, charging time, energy efficiency, and temperature rise.

2) MCC CHARGING OPTIMIZATION

The optimization of Multi-Step Constant Current (MCC) charging poses a significant challenge, particularly in determining the number of current stages and their corresponding rates in the MCC profile. Fuzzy logic technology has emerged as a popular approach for improving MCC charging performance. In [140] and [141], a Charging quality variables, such as charging time and normalized discharged capacity, are transformed using fuzzy logic controller into a single fuzzy dual-response performance index. This approach enables the optimization of a five-stage MCC charging pattern, resulting

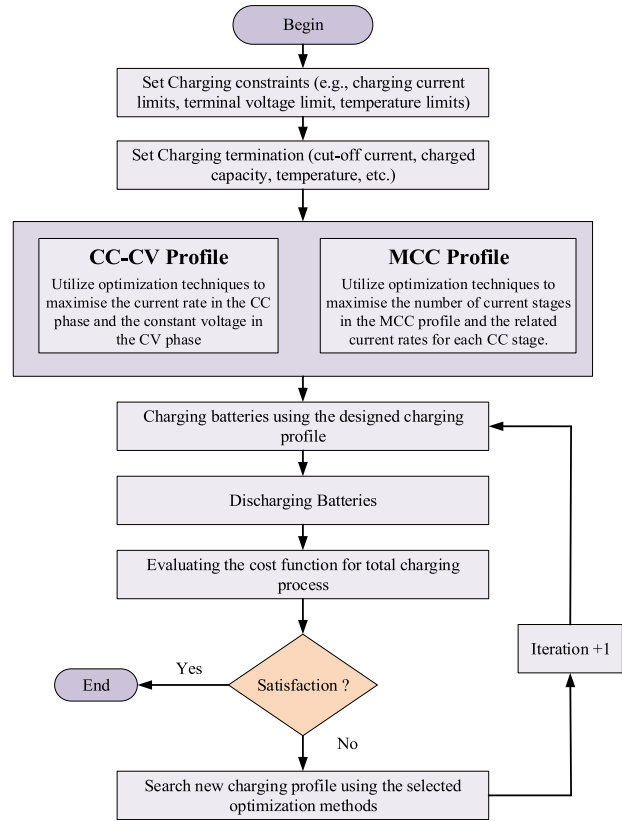

FIGURE 31. Enhanced strategy to the CC-CV/MCC charging.

in improved charging efficiency. Similarly, [142] and [143] employ fuzzy logic control to manage the weights within the Li-ion charging process' fitness function, allowing for the optimization of optimal MCC charging patterns using the PSO algorithm.. Fig 31 provides a summary of the improvements made to the CC- CV/MCC charging approach based on the designed fuzzy-logic fitness function.

Another successful way for locating the ideal MCC charge pattern is the Taguchi-based method. In [144], a Taguchi-based approach is presented to accelerate charging speed and prolong cycle life for Li-ion batteries. Using the consecutive orthogonal array technique, It is optimized to use a five-stage MCC charging pattern. Additionally, [145] combines the Taguchi approach To manage battery temperature variance, charging speed, and energy conversion efficiency, a four-stage MCC charging strategy is suggested using SOC estimates. To improve MCC charging performance, other technologies such ant colony systems, function-based approaches, and model-based approaches have also been used. For instance, [146] introduces an MCC charging approach with varying weights based on an internal-DC-resistance model for each level, aiming to balance the conflicts between charging speed and energy loss. Reference [147] presents a unique approach that utilizes an equivalent circuit model for Li-ion batteries to search for the optimal MCC charging pattern. This approach considers both three

and five CC stages to improve charging speed and efficiency. In summary, The total number of CC stages and the current values assigned to each stage establish the charging goals of the whole MCC charging process, including charging speed, energy loss, and capacity utilisation. Since MCC charging does not require voltage regulation, its implementation costs are lower. Fig. 31 illustrates how the CC-CV/MCC charging strategy has been enhanced [3].

### C. SMART CHARGING

Concurrent EV charging can raise the overall demand for electricity. Without the installation of a smart charging system, there is a high risk that demand will increase when all owners of vehicles connect their EVs at the same time, usually after their final journey of the day upon coming home. This abrupt rise in demand may cause a huge peak load, which would impose a great deal of strain on the grid at both medium and low voltage levels. Within the distributed infrastructure, the right charging strategies must be used in order to guarantee a balanced and consistent load profile [248]. The interplay between the smart grid and EVs is depicted in Fig. 32, demonstrating how these two systems can cooperate to overcome the problems caused by simultaneous EV charging. The grid may optimise and control the charging process based on variables including energy consumption, grid stability, and user preferences by implementing smart charging and Wireless Charging strategies [249], [250], [251], [252].

With the help of this dynamic strategy, the grid can manage EV charging more effectively and equally distribute the load, reducing stress on the system during peak usage. An easier integration of EV charging with the current power grid is made possible by the deployment of smart charging solutions within the context of a distributed infrastructure. In order to prevent problems with peak loads and grid stress, the smart grid and EVs work together to manage charging demand intelligently. Includes a comparison of smart charging, rapid charging, and traditional charging in Table 19. Smart charging is more suited for routine daily charging scenarios and long-term battery preservation since it places a greater emphasis on optimization, grid stability, and battery health. On the other side, quick charging, while it may be more convenient and extend range when travelling or in an emergency, may be more expensive and strain the battery.

## VIII. CELL BALANCING

Battery Energy Storage Systems (BESS) are increasingly being utilized in EVs applications due to their numerous advantageous characteristics. These include rapid demand response, installation flexibility, and short construction time [148]. Consequently, BESS supports the management of voltage and frequency, black-start capability, standing reserve, integration of renewable energy, peak shaving, load leveling, and improvement of power quality in the electrical power system. To achieve the required power, BESS cells are integrated in series or parallel configurations. As a result, SOC imbalance among the cells is a common occurrence in

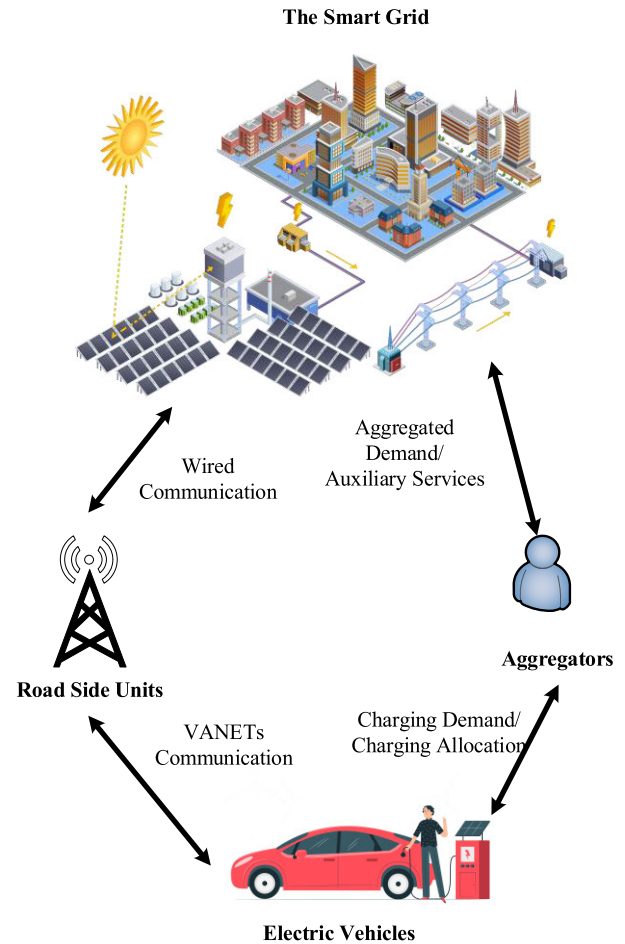

FIGURE 32. Various cell balancing topologies.

BESS, which can be caused by internal or external factors. Cell imbalances are caused by manufacturing flaws, self-discharge rates, internal impedance, and changes in charge storage volume. Additionally, unequal distribution of charging and discharging cycles in an unequal cell string can lead to temperature increases in a BESS [149], [150], [151], [152]. Over the past few decades, numerous cell-balancing topologies have been developed, which can be broadly divided into two categories: active balancing and passive balancing. These categories are determined by the utilization of energy storage elements (ES elements) and the methods employed for energy balancing, as depicted in Fig. 33.

### A. PASSIVE CELL BALANCING

Shunt resistors are used during passive cell balancing to release surplus energy as heat., thereby equalizing the power among cells. In this dissipative cell balancing topology, the excess power of higher cells is reduced until their power matches that of the lower cells. This approach offers advantages such as cost-effectiveness, simplicity, and compactness. However, it also has some drawbacks, including heat dissipation, energy losses, and a longer cell balancing process.

**TABLE 19. Smart charge comparison with fast charging and traditional charging.**

Aspect	Smart Charging	Fast Charging	Traditional Charging
Charging Speed	Based on parameters including grid demand and user preferences, optimizes charging speed to ensure a balanced and controlled charging process.	It provides speedy charging, frequently at a substantially higher power output, to quickly recharge the battery. .	Fixed charging schedules may not be the best for long-term battery health preservation.
Battery Health	Prioritizes battery health by steering clear of rapid charging rates that can cause the battery to lose power over time..	If used regularly, quick charging may put the battery under extra strain and perhaps hasten degeneration.	Fixed charging patterns might not be the best for long-term battery health preservation.
Grid Impact	by planning charging sessions to take place when demand is at its lowest, grid stress is reduced.	Fast charging may result in increased peak demand and significant grid infrastructure modifications. .	If multiple vehicles charge at once, it can add to peak demand, putting potential grid strain.
Energy Cost	Benefit from cheaper electricity during off-peak hours, possibly lowering charging expenses.	Higher charging expenses may result from fast charging being more expensive per kWh.	Charges the same amount throughout the day, which could lead to higher charging fees during peak hours.
Charging Flexibility	Flexible scheduling of charging sessions based on grid and vehicle owner optimal times.	Less flexible scheduling, typically utilised for quick top-ups or when drivers require a speedy charge.	Fixed charging sessions depending on a predetermined schedule or user input.
Convenience	Even though it might not offer the fastest charging speed, it guarantees a full battery at the scheduled departure times.	It provides high-speed charging, which is perfect for on-the-go charging and long-distance trips.	Requires manual charging start and stop, which may not be as handy for the user.

Shunting resistors are commonly employed for passive cell balancing [153], [154].

### B. ACTIVE CELL BALANCING

Comparing active cell balancing to passive cell balancing techniques, active cell balancing has shown to perform better. It involves the transfer of excess energy between BESS cells using components such as capacitors, converters, transformers, and inductors, rather than relying on shunt resistors. Through this approach, cells with excessive energy transfer their surplus to cells with lower energy levels, effectively achieving cell balance without wasting energy. This active balancing topology is not limited by the specific chemical properties of the cells, making it applicable to various battery technologies. Major advantages of active cell balancing include high efficiency and fast balancing speed. However, it should be noted that the implementation of active cell balancing can be complex and costly. Active cell balancing is further classified into three categories based on the active elements utilized: capacitors, converters, or inductors and transformers [155], [156].

#### 1) CELL BALANCING BASED ON CAPACITOR

It transferring energy between adjacent cells. This process involves shifting energy from cells with higher energy levels to cells with lower energy levels. However, there are some drawbacks associated with capacitor-based balancing. One disadvantage is the energy loss that occurs during the charging of the capacitors. Additionally, there may be a delay in achieving cell balance due to the time required for the energy transfer process. Switched capacitors are commonly employed in various configurations, including single tiered,

double-tiered, and multiple capacitors [157], to facilitate the cell balancing process.

#### 2) CELL BALANCING BASED ON A TRANSFORMER OR INDUCTOR

Transformers or inductors are utilized in achieving cell balance by transferring energy between cell modules or individual cells. This transfer of energy allows for rapid attainment of cell equilibrium. However, this method has a drawback that requires the inclusion of filter capacitors across each cell. This requirement adds to the overall cost and frequency considerations associated with the transformer. Different variations of this approach include single-winding transformers, multi-winding transformers, multiple inductors, and single/multi-inductor configurations [158], [159].

#### 3) CELL BALANCING BASED ON A CONVERTER

Converter-based cell balancing has gained significant traction due to its ability to effectively control the entire balancing process. However, cost and complexity are still significant challenges associated with this approach. In this method, a standard or modified DC-DC converter, such as a buck converter, boost converter, buck-boost converter, flyback converter, resonant converter, full-bridge converter, cuk converter, or PWM converter, is employed for the balancing operation [160], [161].

#### 4) COMPARATIVE ANALYSIS

Table 20 provides a comparison of balancing speed, charge/discharge capabilities, and primary components required for balancing and cell application. Passive cell



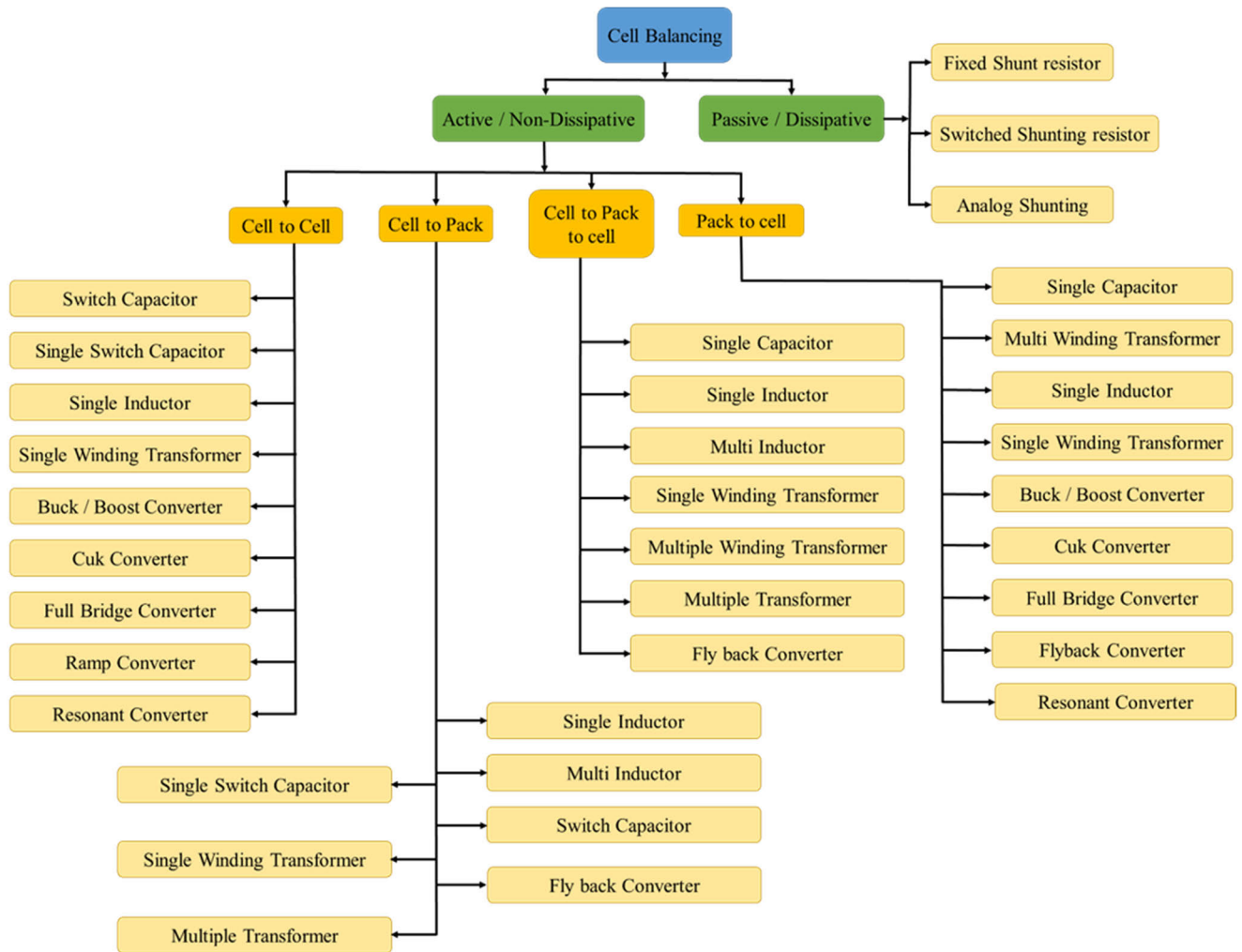

FIGURE 33. Various cell balancing topologies.

balancing is suitable for applications with low power consumption as it involves minimal resistance for continuous operation. Additionally, passive cell balancing is cost-effective. On the other hand, active cell balancing offers greater energy savings and can handle higher power loads compared to passive cell balancing. Full-bridge converters, if used appropriately, can address two key challenges faced by BESS, namely DC/AC power conversion and cell balancing. They also offer the advantage of fast balancing speed. During the charging or discharging process, the cell with lower energy is prioritized over the cell with higher energy, ensuring efficient energy management [162].

**IX. BATTERY THERMAL MANAGEMENT SYSTEM (BTMS)**

To keep batteries in a battery pack from overheating, a number of pieces of hardware, software, and other elements collaborate effectively. Among these, the BTMS plays a crucial role in maintaining a constant temperature for batteries and battery modules. The effectiveness of the BTMS directly affects the lifespan of batteries and ensures their thermal safety. Since batteries are used in diverse applications and

environments, the BTMS must be designed to adapt to different working and ambient conditions. Extreme temperatures, whether high or low, can negatively impact battery performance, and thus, appropriate cooling or heating methods should be implemented. However, improper design of heating/cooling techniques may lead to temperature variations and non-uniformity within the battery pack, compromising temperature stability, safety, and battery life. Therefore, the development of an efficient BTMS is essential to address these challenges and maintain temperature uniformity in the battery pack. A well-designed BTMS also facilitates the distribution of temperature throughout the battery pack, while ensuring factors such as weight, compactness, reliability, cost-effectiveness, and feasibility for automotive applications. External BTMS solutions utilize air or liquid to cool the battery cells, without modifying the materials of the batteries themselves. These external BTMS options include active BTMS (such as thermoelectric, liquid, and air-based BTMS) that use energy to cool the batteries while in use, as well as passive BTMS that employ phase change materials (PCMs) and heat pipes to cool the batteries without power

**TABLE 20. Comparison of various cell-balancing topologies [152], [153], [154], [155], [156], [157], [158], [159], [160], [161], [162].**

Technique	No. of Elements for Balancing (n cells)	Time, Complicity	Voltage and Current Stress	Power Loss, Efficiency	Size and Cost	Advantages	Disadvantages
PWM Controller, Active and Charge/Discharge	n switches, 2 resistors and 2 diodes, n - 1 inductors	Medium, Complex	High/High	Low, Better	Large, Costly	Bidirectional, medium balancing efficiency,	Several switches and components are required for balance, and stress from high current and voltage, and the control system
Complete Shunting Balancing, Active and Charge	2n switches, n diodes	Medium, Complex	Low/Low	Minor, Good	Small, Cheap	Average balancing effectiveness, small size, and cheap	Work only in charging mode
Resonant Converter, Active And Charge/Discharge	2n - 2 switches, n - 1 indicators, n - 1 capacitors	High, Complex	Low/Low	Very Low, Better	Medium, Costly	Bidirectional, high Balancing efficiency, less power loss, ideal for HEV and EV due to reduced current and voltage stress	Requires intelligent and appropriate voltage sensing, complex control system
Multi-winding Transformer, Active and Charge/Discharge	2 switches, n diode, 1 winding transformer, n + 1 inductors	Medium, Complex	Medium /Low	Low, Better	Large, Costly	Bidirectional, ideal for use in HEV and EV applications, medium balancing speed	For balance, a complex control system, as well as a high magnetic loss and high dimension, many switches and components are needed.
Fly-Back Converter, Active and Charge/Discharge	2n switches, 2n inductors, n winding transformers	Medium, Medium	Low/Low	Low, Good	Large, Costly	Low power loss, current, and voltage stress, medium balancing speed, and bidirectional	A complex control system, huge size, and expensive are needed for balancing, as well as a number of switches and components.
Boost Converter, Active, and Charge/Discharge	n + 1 switches, 1 diode, n + 1 indicators 1 capacitor	High, Complex	Low/Low	Minor, Better	Medium, Medium	High balancing speed, bidirectional, low current and voltage stress, minimal power loss	requires a sophisticated control system, adequate and clever voltage sensing, and high cost.
Ramp Converter, Active and Charge/Discharge	n switches, n diodes, n/2 inductors, n capacitors	Medium, Complex	Medium/ Medium	Low, Good	Large, Costly	Bidirectional, soft switching, low power loss, and high efficiency	For balance, a complex control system with pricey switches and components is needed.
Full-Bridge Converter, Active And Charge/Discharge	2n + 2 switches, 2 capacitors	Medium, Complex	High/High	Low, Better	Large, Costly	Bidirectional, high Balancing efficiency, power loss is negligible	Complex control system, costly
Fixed Shunt, Passive and Fixed	n resistors	Slow, Very simple	Zero/Zero	Very High, Poor	Very Small, Very Cheap	tiny size, inexpensive, and a very basic control system	Inefficient balancing, excessive power loss, need for thermal control
Analog Shunt, Passive, and Only Charging	n switches, n Op-Amps, 3n resistors, n Capacitors	Slow, simple	High/High	High, Low	Very Small, Cheap	simple, compact, and affordable control system	Poor efficiency, high power loss, and a need for thermal control
Switch Shunt, Passive and Only Charging	n resistors n switches	Slow, simple	High/High	Very High, Low	Very Small, Very Cheap	Simple control system, inexpensive and compact, appropriate for use in HEV but	Inefficient balancing, excessive power loss, need for thermal control

**TABLE 20. (Continued.) Comparison of various cell-balancing topologies [152], [153], [154], [155], [156], [157], [158], [159], [160], [161], [162].**

Single-Switch Capacitor, Active and Charge/Discharge	n+5 switches, 1 capacitors	Medium, Complex	Low/Low	Minor, Better	Small, Medium	with some restrictions when used in EV Bidirectional, Easy to use, effective, and ideal for HEV and EV applications	Complex control system, slight power loss
Double-Tiered Switch capacitor, Active and Charge/Discharge	2n switches, 2n-3 capacitor	Medium, Complex	Low/Low	Minor, Better	Medium, Medium	Compared to switch capacitors, it is bidirectional, efficient, and quick to balance.	Need for many switches, medium equalisation speed
Switch Capacitor, Active and Charge/Discharge	2n switches, n-1 capacitor	Medium, Medium	Low/Low	Minor, Better	Medium, Medium	simple control, minimal current and voltage stress, and bidirectional	Need for many switches, medium equalisation speed
Single Inductor, Active and Charge/Discharge	2n-2 switches, 1 inductor, 2n-2 diodes	High, complex	Low/Low	Low, high	Medium, Medium	Low voltage, low stress, low current, and bidirectional	sophisticated control, several switches and diodes required
Modularized Switch Capacitor, Active and Charge/Discharge	M(n+2) switches, M(n-3) capacitor	Medium, Complex	Low/Low	Minor, Better	Medium, Medium	Bidirectional high power application under low current and voltage stress	requires a huge number of switches, a sophisticated control system, and is expensive.
Multi Inductor, Active, and Charge/Discharge	n + 1 switches, n - 1 inductors	High, Complex	Low/Low	Low, High	Large, Medium	Bidirectional, minimal power loss, low current and voltage stress, and quick balancing are all advantages over a single inductor and switch capacitor.	sophisticated control system, several switches, and current filter capacitor required
Single Winding Transformer, Active and Charge/Discharge	n + 6 switches, 1 diode, 2 indicators, 1 transformer	Medium, Complex	Medium/Medium	Low, Better	Large, Costly	Low magnetising loss, medium balancing speed, and bidirectional	requires a complicated control system that balances various switches and components.
Modularized Winding Transformer, Active and Charge/Discharge	M(n + 2) switches, Mn diodes, M(n + 2) indicators, M - 1 transformers	Medium, Complex	Low/Low	Very Low, Better	Large, Costly	suited for usage in HEV and EV systems as well as high-power ES systems	For balance, a complex control system, enormous size, and expensive switches and components are needed.
Buck-Boost Converter, Active And Charge/Discharge	2n - 2 switches, n - 1 inductors	Very High, Complex	Low/Low	Minor, Better	Medium, Medium	High balancing speed, bidirectional, low current and voltage stress, minimal power loss	requires a sophisticated control system, intelligence, and adequate voltage sensing.
Cuk Converter, Active and Charge/Discharge	2n - 2 switches, 2n-2 inductors, N - 1 capacitors	High, Complex	Low/Low	Low, Better	Medium, Medium	High-efficiency bidirectional balancing, low current and voltage stress, and suitability for HEV and EV	A complex control system, huge size, and expensive are needed for balancing, as well as a number of switches and components.

consumption. PCMs can be categorized into composite-PCM BTMS and pure-PCM BTMS. Numerous research organizations have reported on various BTMS for batteries. It is

significant to note that more aggressive thermal control is necessary due to the fast charging's growing charge rates. However, existing external battery management systems

often struggle to perform well under fast-charging conditions. In some electric vehicles, the heat-transfer coefficient of forced convection is relatively low, hindering the achievement of extreme fast-charging (XFC). Additionally, the radiator may not be sufficient in warmer climates where ethylene glycol is used as a coolant, hence some EVs have a separate vapour compression refrigerant (VCR) system to lower the coolant temperature below ambient and increase cooling. However, this design may lead to increased pumping power consumption. To address these challenges and achieve rapid heat dissipation, future advancements may involve an integrated two-phase cooling system for the battery pack. Although installing such a system would be expensive and time-consuming, its promise for efficient cooling makes it a worthwhile endeavor. Consequently, to meet the demands of fast charging and XFC, a comprehensive and adaptive advanced BTMS is necessary to ensure temperature uniformity and efficient heat management. Fig. 34 illustrates several thermal management methods.

#### A. THERMAL RUNAWAY (TR)

Thermal runaway in batteries is typically characterized by the progression of temperature and peak heat release. It involves three steps: abnormal heat generation, initiation of fire and explosion, which correspond to specific temperature thresholds. The events leading to thermal runaway can be categorized into two paths: internal and external. The internal path relates to thermal failures occurring inside the cells due to chemical reactions, while the external path involves the smoke, and eruption/fire observed outside the cells [173]. The complete sequence of thermal runaway events is illustrated in Fig. 35. In the internal pathway, the SEI's breakdown causes the cells' temperature to rise, which causes aberrant heat generation (step 1). The temperature continues to rise until it reaches the triggering level due to ongoing degradation and regeneration of the SEI (step 2). This can be primarily caused by three factors: internal short-circuits due to separator damage, Release of oxygen from the cathode and the development of active lithium on the anode surface, particularly while charging quickly. These elements may cause the cell temperature to increase to 280°C from 60°C. At higher temperatures (beyond 660°C), redox reactions intensify, leading to gas formation and rupture of active elements in the current collector [174]. This, in turn, increases temperature and pressure, initiating venting. As the temperature and pressure continue to rise (exceeding 1200°C), electrolyte components undergo continuous combustion and venting, ultimately resulting in a severe explosion. The sequences in the exterior path begin with swelling and progress through venting initiation, forceful venting, and explosion. Solvents inside the cell gasify when temperatures rise over their boiling points as a result of abnormal temperature rise brought on by short circuits, oxygen escape, or lithium plating, which causes battery swelling. When the pressure exceeds its limit, the high temperature causes a variety of compounds inside

the cell to boil, starting the first step of venting. Dark smoke and a small amount of fire are produced as a result. Continuous solvent boiling causes re-combustion inside the cell and ferocious gaseous electrolyte venting [175]. The temperature and pressure continue to rise unabated, culminating in an explosion. Exothermic reactions occur successively during thermal runaway, and the heat and gas generated during this process can cause the battery to catch fire or explode. Several factors can contribute to thermal runaway, excessive temperatures, overcharging, short circuits, and battery damage caused by physical forces. The SOC of the battery also affects its susceptibility to overheating and thermal runaway. Research indicates that higher SOC levels increase the likelihood of thermal runaway, particularly for new batteries [176]. However, the SOC has the temperature at which thermal runaway occurs is unaffected significantly in older batteries. Preventing thermal runaway currently relies on a limited number of technologies, such as incorporating inhibitors into battery materials. Nevertheless, there is no quick and easy way to stop battery deterioration in hot environments. The development of an efficient BTMS is considered the most effective approach to prevent thermal runaway [177]. A well-designed BTMS enables better control of battery thermal behavior by operating the batteries within safe temperature ranges and ensuring uniform heat distribution throughout the battery pack. This helps to slow down the occurrence of thermal runaway.

LiFePo<sub>4</sub> and NCM (Lithium Nickel, Cobalt, and Manganese) batteries were studied at various SOC levels in a study by Wang et al [178]. The results indicated that batteries with a higher SOC are more susceptible to overheating and thermal runaway. Specifically, For fresh batteries, the SOC increases as the temperature at which thermal runaway starts to occur falls. However, with older batteries, the SOC has little to no impact on the temperature at which thermal runaway occurs [179]. Currently, there are limited technologies available to prevent thermal runaway. One approach is to incorporate inhibitors into battery materials [180]. However, there is no straightforward and effective way to avoid battery damage in hot environments. The development of an efficient BTMS emerges as the most effective solution for preventing thermal runaway. By implementing a well-designed BTMS, it becomes feasible to exercise more control over the thermal behaviour of the battery. Keeping batteries at a safe temperature and making sure the battery pack is evenly heated can help slow down the occurrence of thermal runaway [181].

#### B. LOW-TEMPERATURE HEATING METHODS IN EV THERMAL MANAGEMENT

In regions with cold climates, maintaining optimal battery performance and efficiency becomes even more critical for electric vehicles. Cold temperatures can have a negative impact on battery capacity, internal resistance, and overall energy output. To address these challenges, EV manufacturers and researchers have explored various

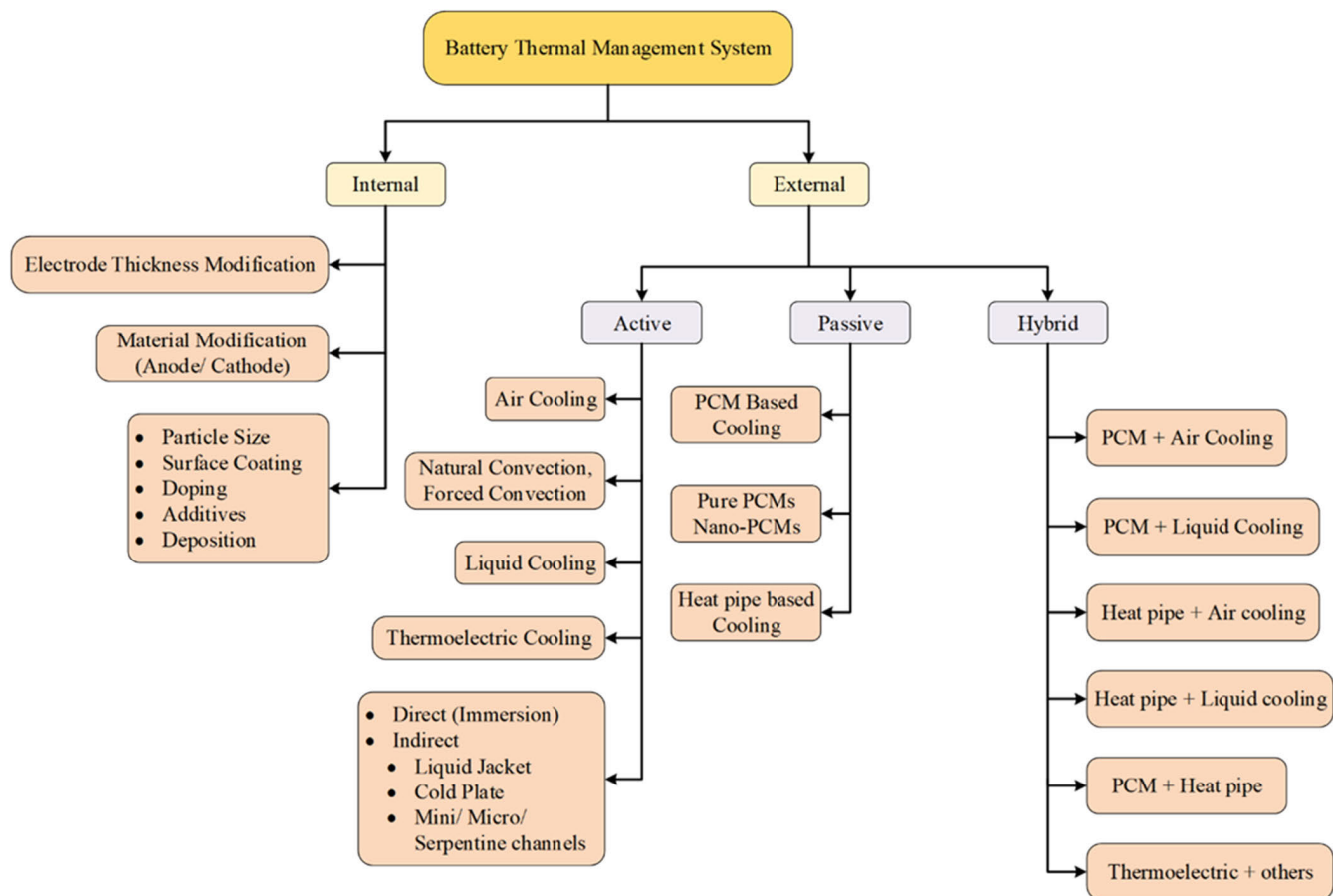

FIGURE 34. Classification of BTMS.

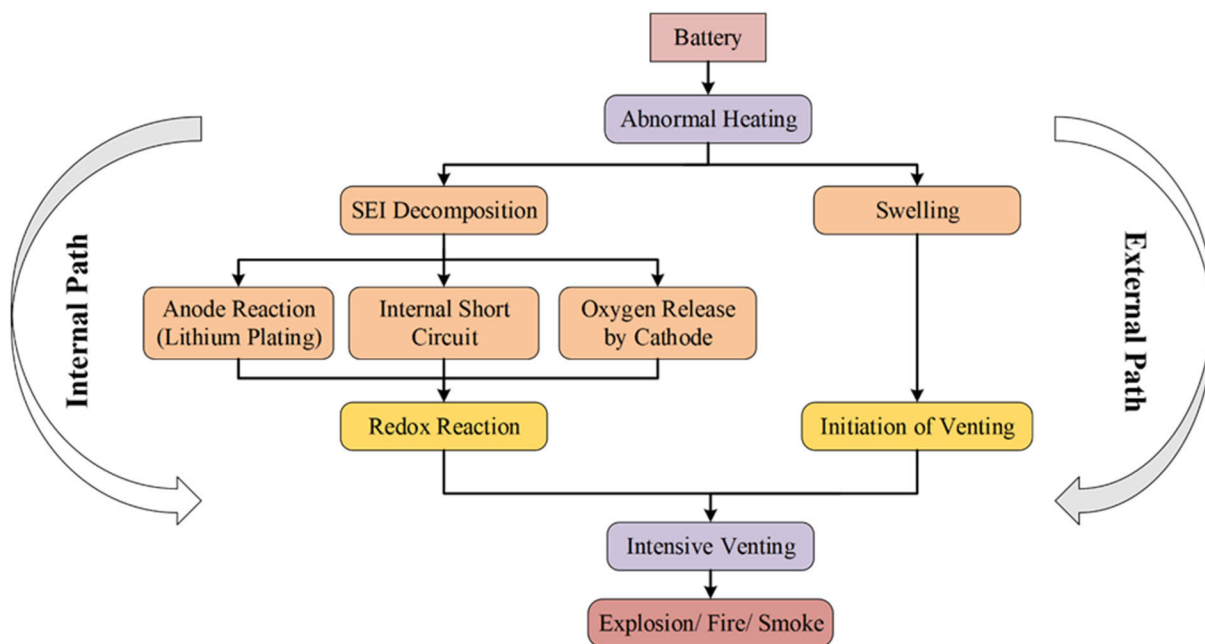

FIGURE 35. Sequence of events during thermal runaway.

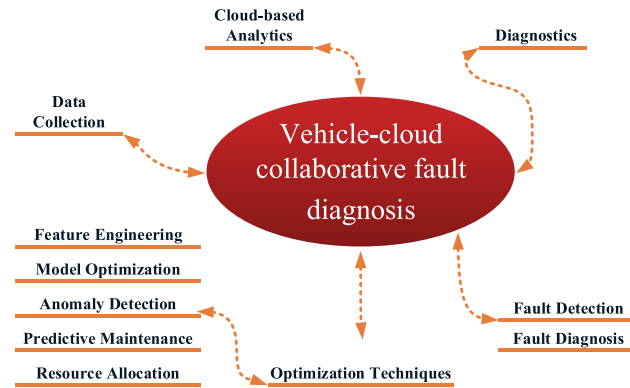

FIGURE 36. Sequence of events during thermal runaway.

low-temperature heating methods as part of their thermal management strategies:

#### 1) BATTERY PRE-HEATING

Pre-heating the battery before driving helps improve its efficiency and performance in cold conditions. By using resistive heating elements integrated into the battery pack, manufacturers can raise the battery's temperature to an optimal range before the vehicle starts moving.

#### 2) CABIN AND BATTERY THERMAL COUPLING

Some EVs utilize waste heat generated by the powertrain or battery to warm the cabin and battery pack. This approach is energy-efficient as it uses existing heat sources to maintain suitable temperatures.

#### 3) THERMAL INSULATION

Implementing better thermal insulation for the battery pack and critical components helps reduce heat loss to the environment. This can prevent the battery from getting too cold during extended periods of inactivity.

#### 4) ACTIVE THERMAL MANAGEMENT

equipped with active thermal management systems use dedicated heating circuits that circulate a warm coolant through the battery pack, power electronics, and cabin heaters. This method ensures a consistent and controlled temperature across key components.

#### 5) HEAT PUMP SYSTEMS BATTERY PRE-HEATING

Some EVs incorporate heat pump systems that can extract heat from the external environment, even in very cold conditions, and transfer it to the cabin and battery. This method is energy-efficient and effective in maintaining suitable temperatures.

#### 6) INTELLIGENT ENERGY MANAGEMENT BATTERY PRE-HEATING

By analyzing weather forecasts and trip plans, EVs can intelligently adjust their thermal management strategies. For

example, the vehicle can initiate battery pre-heating before a trip in cold weather.

### 7) CHALLENGES AND CONSIDERATIONS

While low-temperature heating methods offer several benefits for EVs in cold climates, there are challenges to consider:

*Energy Consumption:* Some heating methods can consume a significant amount of energy, which might impact the vehicle's driving range. Balancing heating needs with energy efficiency is crucial.

*System Integration:* Implementing these methods requires close integration with the vehicle's electrical and thermal systems, which can be complex and require advanced control algorithms.

*Component Durability:* Heating elements and systems should be designed for long-term reliability and durability, considering the stress of temperature cycling.

Incorporating low-temperature heating methods into EV thermal management is vital for ensuring optimal battery performance, extending battery life, and providing a comfortable driving experience in cold climates. Manufacturers continue to research and develop innovative solutions to strike the right balance between energy efficiency and effective thermal management.

## X. ISSUES, CHALLENGES AND ITS RECOMMENDATION

### A. ISSUES AND CHALLENGES

#### 1) ISSUES WITH DATA VARIETY, ABUNDANCE, AND INTEGRITY

The amount and variety of data that are accessible have a significant impact on how well advanced algorithms perform in battery models. However, acquiring a substantial and diverse dataset can be a time-consuming process, leading to increased computational complexity and the potential risk of overfitting [43]. To maintain data integrity, fixed charge/discharge patterns and controlled temperature settings are employed in the data bank. Nevertheless, laboratory battery test benches are prone to issues such as limited accuracy, high levels of noise, and electromagnetic interference (EMI). As a result, it is crucial to evaluate the BMS under various real-world scenarios to ensure its reliability and performance.

#### 2) SELECTION AND OPTIMIZATION OF PARAMETERS FOR INTELLIGENT ALGORITHMS

The framework, input features, training approaches and hyperparameter choice all affect how well intelligent algorithms function. Achieving optimal performance through proper design and hyperparameter tuning can be challenging, often leading to issues such as data underfitting or overfitting [93]. Selecting the right structure and hyperparameters for intelligent algorithms typically involves time-consuming trial-and-error methods, which can be tiring for people. Both intelligent approaches and various control methods require optimization. However, the convergence rates and execution

times of optimization methods differ, and success rates of achieving desired outcomes.

### 3) BATTERY CHARGER AND DISCHARGING ISSUE

The absence of universal battery chargers poses a challenge for BMS. Existing custom battery chargers are often designed for specific purposes and tend to be bulkier, resulting in more electrical clutter and waste for the environment. Dealing with the diverse range of batteries in use becomes a concern for battery charger designers. Additionally, handling damaged or aged batteries requires the use of safe-discharge methods to mitigate potential risks. Batteries immersed in electrolytes can generate hydrogen and oxygen gases, necessitating proper ventilation to prevent explosions. The use of resistors for discharging batteries requires careful regulation of current to prevent overheating [8].

### 4) EARLY DISCHARGE TERMINATION AND CELLS DEGRADATION

The existence of a lower-capacity cell among the series-connected cells can cause cell imbalance when all of the battery cells in a pack have the same SOC at the beginning. While the overall voltage of the pack may reach a desired level, individual cell voltages will vary. The lower cell's voltage may increase to a dangerous level if its capacity is less than 10%, increasing the chance of cell breakage and raising safety issues. This auto-accelerating process of cell breakdown presents challenges in managing the BMS. In order to prevent further capacity reduction, the BMS may terminate discharge early when a lower voltage threshold than the pack's designated threshold is reached by the cells in the pack. The battery discharge duration can be improved by avoiding the low-capacity cells, but the BMS must be more sophisticated and expensive as a result. Additionally, overcharging can also lead to potential hazards such as detonation [8].

### 5) AGING AND MEMORY EFFECT

Battery aging occurs as a result of internal resistance and capacitance degradation, which is further accelerated by high temperatures. Unfortunately, it is difficult to determine when a battery is approaching the end of its lifespan until it abruptly fails. To address this issue, a battery model that takes into account aging factors is necessary. One particular effect of repeated charge-discharge cycles is the memory effect, which manifests as reduced memory capacity and potential cell imbalances [195].

### 6) SECURITY AND POSSIBLE RISKS

During the cycling process, each individual cell within a battery may exhibit different responses, leading to potential safety concerns. The performance of LIBs can also be harmed by variables like temperature changes and outside environmental factors. Leakage, insulation cracks, and short circuits are a few problems that might result from battery

deterioration. Additional dangers can be introduced by opening LIBs to the air or submerging them in water, such as explosions, spontaneous combustion, and exothermic reactions involving lithium ions and oxygen. These reactions can be extremely dangerous and even fatal. The proximity of highly reactive substances in batteries also poses risks. Overheating or overcharging can lead to fires or explosions, while exceeding the maximum voltage can result in the dissolution of the cathode, increasing the risks of heat generation and short circuits. Excessively high voltages can also cause decomposition of the electrolyte, posing significant harm [196], [197].

### 7) SAFE AND EFFICIENT OPERATION

Loss of capacity in LIBs can result in extended operations. To prevent overloading, a charging interruption is triggered when a serially connected battery goes over the maximum voltage of 4.35 V. Undercharged batteries, on the other hand, tend to have a shorter lifespan. One of the challenges with batteries is the absence of a well-defined safe working range, as internal and external factors continually fluctuate. This lack of a stable working range raises concerns regarding the reliability and stability of individual battery cells. Additionally, maintaining an optimal operational condition becomes challenging, particularly requiring peripheral control units inside the BMS, as a variety of events can greatly affect the battery electrochemical characteristics [198].

### 8) BATTERY RECYCLING AND REUSE

The recycling of batteries is a pressing issue that requires attention in order to manage the increasing volume of spent LIBs effectively. Establishing a system for the collection and recycling of batteries is crucial to mitigate environmental concerns and enhance recycling possibilities. However, there is a lack of a well-defined procedure that minimizes negative environmental consequences. Another challenge for BMS pertains to the reuse of batteries. BMS algorithms heavily rely on battery characterizations conducted in laboratories, which are only valid for a single instance. As batteries are used and exposed to varying environmental conditions, their electrochemical properties change over time. Therefore, assuming that old batteries possess the same characteristics as new ones can be unsafe. Additionally, batteries contain metals such as copper, aluminum, and cobalt. Given It would be unfortunate if the mining for these battery-useful metals increased due to their rising costs beneficial to explore options for reusing these batteries. Currently, retired batteries in bulk are being utilized for applications such as renewing ESS worldwide. The BMS is essential for guaranteeing the safe operation of second-life cycle batteries [198].

### 9) BATTERY DISPOSAL ISSUES

Proper disposal of certain types of spent batteries is crucial due to their classification as hazardous waste. Incorrect disposal of these LIBs can lead to explosions, environmental

issues, and safety hazards. Moreover, there is a potential for incurring cleanup expenses. The process of disposing of batteries is intricate and includes fees for treatment, transportation, and disposal as well as regulatory constraints.

#### 10) MISCELLANEOUS ISSUES

Building a database of driving patterns and other relevant information for EVs depends heavily on data logging functionalities, however the BMS confronts many difficulties in this area. However, the complexity, cost, weight, power consumption, and difficulty in pressure regulation are inherent drawbacks of BMS circuitry. A BMS has a constrained number of data logging features available. The advancement of EV technology necessitates a sophisticated BMS that can effectively handle energy computation and ensure safety in the presence of SOC imbalances in the Li-ion battery pack. The evaluation and comparison of different prognostic techniques have received less attention, resulting in lower efficiency compared to diagnostics. A portable battery testing equipment is also required when employing battery modules made by different manufacturers to assess these batteries. There are variety of solutions to these problems and challenges are presented in the following sections.

### B. RECOMMENDATIONS

#### 1) COMBINING WITH BIG DATA

The use of big data platforms, cloud computing, and cloud storage platforms offers a chance to improve the precision of intelligent algorithms. Implementing digital twins and cloud-based BMS systems can solve data recording and computational problems. These advancements enable real-time training with improved precision and accuracy.

#### 2) REUSE AND RECYCLING

Efforts should be directed towards researching battery reuse as a means to conserve surplus energy while prioritizing environmental sustainability. This approach also contributes to the preservation of the Earth's supply of Li-ion batteries is constrained. Recycled batteries retain valuable energy, and with Tesla Roadster's battery alone consisting of 6831 cells, proper recycling is essential to prevent significant waste. Collaboration between governmental and non-governmental organizations is crucial to develop cost-effective and environmentally friendly technologies for recovering energy and resources from old batteries. It is important to establish universal and consistent regulations for the disposal of used LIBs, enabling the work of science and industry while encouraging environmental protection.

#### 3) IMPROVING LIBS CAPACITY AND CHARGING QUICKLY

The capacity of LIBs is influenced by various hidden factors such as vibrations, environmental conditions, operational parameters, and technical variations, making accurate degradation predictions challenging. To prolong the LIBs' usable

lifetime, it becomes required to design new technologies. Innovative abnormality detecting techniques and a variety of driving types are required to enhance battery efficiency and prediction accuracy. The widespread adoption of electric vehicles has necessitated the need for an advanced battery management system capable of preventing overcharging and overheating during fast-charging processes. The BMS charging system's objective should be to implement an efficient, safe, and optimized charging strategy. Wireless Charging strategies [252], [253], [254], [255], [256].

#### 4) LIFE CYCLE ANALYSIS AND THE IMPACT OF AGING

Additional study is required to determine how new materials affect battery lifespan trends. LIBs should be designed using materials that are abundant, cost-effective, non-toxic, and easily recyclable. Through model simulations, it is possible to improve the lifespan of battery packs by incorporating new materials without compromising their steady-state performance. This approach will garner greater interest from battery manufacturers while reducing the recycling burden and disposal infrastructure. Understanding how ageing affects LIB parameters is essential for accurately predicting the SOH of batteries. The complex and interconnected dynamics of battery aging necessitate the development of novel approaches.

#### 5) INSTALLATION RECOMMENDATIONS

Observing equipment ratings and labelling guidelines should be strictly followed. When replacing equipment, compatibility with the existing setup must be ensured, preferably verified by a third party to ensure product safety and avoid any mistakes made by manufacturers or designers. In cases where battery replacement is required, it is advisable to replace the entire battery bank rather than a few individual batteries. It's crucial to keep a safety logbook and do routine BMS safety checks in order to comply with new standards and make the necessary adjustments. A tamper-proof BMS requires meticulous attention to hardware and software manipulation, whereby the BMS notices unusual behaviour or readings, the load or charger should be immediately disconnected and reset.

#### 6) NEW SENSOR-ON-CHIP

State estimate, defect forecasting, and health diagnostics all largely rely on different battery characteristics, regardless of the model or approach employed. Hence, it is important to incorporate diverse sensors capable of capturing the required parameters. The integration of different sensors into a single chip, known as sensor-on-chip, represents a promising direction to compact the BMS. Specifically, on-chip thermal sensors can be mounted on or inside the battery, creating a wireless sensor network for controlling surface and inside temperatures. A more intelligent BMS for EV batteries is anticipated to result from the advancement of sensor-on-chip technology.



## XI. RESEARCH GAPS

### A. JOINT ESTIMATION TECHNIQUE

Traditionally, battery states are treated independently, with a majority of studies focusing on single-state estimation. However, limited research has been conducted on joint estimation, where multiple states are considered simultaneously. While joint estimation can yield satisfactory outcomes under particular circumstances, it has certain limitations, particularly when dealing with the strong interdependencies among three or more states in real-time applications [23]. Therefore, The creation of an efficient BMS capable of accurately calculating all the vital battery states is crucial, including the SOC, SOH, SOP and SOE.

### B. BATTERY PACK EQUALIZATION, UNIFORMITY AND REUSE CRITERIA

The homogeneity criterion, which is normally taken into account at the pre-manufacturing stage, was the main consideration in the design of battery packs in this study. However, it is crucial to recognize that the performance of designed battery packs cannot be guaranteed solely based on this criterion when they are in operation. Battery packs are used in electric vehicle operations, often face challenges related to cell imbalances, referred to as the equalization problem [199], [200]. Additionally, after the lifespan of battery packs, they are often left unused due to neglecting recycling and reuse methods or a lack of awareness among potential buyers. One potential solution is to gather these battery packs, recognise and group cells that have remaining life, and then create fresh battery packs from these clusters. Otherwise, the buildup of wasted batteries can cause major disposal problems and have a detrimental effect on the environment [201]. As a future direction, the authors could consider creating a complete design technique that incorporates the reuse, equalisation, and uniformity criteria. Such an approach would be valuable for creating robust battery pack designs capable of functioning effectively during the operation of vehicles.

### C. REDESIGN, SETUP, LOCATION AND COMPONENTS OF BATTERY PACK

A promising research avenue would involve redesigning battery packs and their components to optimize space utilization within vehicles, minimize vulnerability to crashes, and facilitate easy dismantling, disassembly, and replacement for efficient and user-friendly recycling [202], [203]. The detailed exploration and study of topology design optimization for electric vehicles, including integrated components such as battery packs, could be of significant interest. Another emerging area focuses on photovoltaic systems and batteries working together and supercapacitors to enhance vehicle efficiency, range, and energy storage, particularly in situations where excess energy is generated from hybrid systems. For instance, a microgrid EV charging station with a solar system, wind power, and Li-ion battery storage can enable power export when generation in the microgrid outpaces demand and offer backup power during grid disruptions [204].

### D. REDUCED SAFETY-RELATED ISSUES

Special attention should be given to environmental considerations, particularly regarding safety concerns such as cathode failure, electrolyte failure, overcurrent, overvoltage, low current, low voltage, and others, to prevent irreversible damage to battery cells. To mitigate such problems, the integration and improvement of features like pressure vent controllers, circuit interrupters, The BMS may benefit from sophisticated switching methods and a dependable thermal management module. Furthermore, it is crucial to address the environmental impact of materials like cobalt, nickel, and others that are utilised in Li-ion batteries [205]. Extensive research has demonstrated their contribution to global warming and environmental toxicity.

### E. INFORMATION AND ENERGY INTERNET FOR VEHICLES

EVs can share knowledge and energy to lessen their dependency on local batteries and BMS. Vehicle-to-vehicle (V2V) operations can be developed to establish a network for transportation energy, which can be integrated into a vehicular Internet of Things (IoT) to support collaborative autonomous driving and advance transportation systems [206]. Operations allowing the sharing of private data and energy packets from EV batteries with energy routers are known as vehicle-to-home (V2H), vehicle-to-grid (V2G) and V2V. This concept of a vehicular information and energy internet (VIEI) for energy and data sharing. This infrastructure also makes it easier for several EVs and the larger internet to share processing resources. EVs will be used for more than just transportation because to the fusion of artificial intelligence (AI) and cloud computing (CC) technology. In order to embrace the integration of information, energy, and humanity, both EV batteries and their BMS will develop with new functionalities [207], [208]. However, Keeping vehicle data and energy secure and private in the VIEI presents new hurdles in fending off hostile attackers. As a result, experts have looked into potential strategies to increase the system's security and privacy, including blockchain technology, CC, and AI [240]. These brand-new technologies will greatly contribute to building a smarter VIEI.

### F. VEHICLE-CLOUD COLLABORATIVE FAULT DIAGNOSIS

Vehicle-cloud collaborative fault diagnosis in the realm of electric vehicles refers to the fusion of on-board vehicle diagnostics with cloud-based analysis and support. This strategy exploits EVs' internet connectivity and cloud computing resources to boost fault identification, issue resolution, and maintenance strategies. It offers benefits to both users and manufacturers: Real-Time Monitoring and Data Collection: EVs employ a range of sensors to monitor diverse systems, like batteries, motors, and power electronics. These sensors continually gather performance and health data. Remote Analysis and Predictive Maintenance: Vehicle data is sent to the cloud, where advanced algorithms and machine learning decipher it. This analysis can pre-emptively identify issues,

leading to proactive maintenance and reduced downtime. Enhanced User Experience: Vehicle owners receive early alerts about potential problems or upkeep needs, enabling efficient scheduling of maintenance visits and preventing unexpected breakdowns. Efficient Service and Support: Service centers remotely access real-time diagnostics from the cloud, enabling accurate solutions without the vehicle's physical presence. Data-Driven Improvements: Aggregated data from multiple vehicles yield insights that aid manufacturers in refining their products through informed design and manufacturing enhancements. Challenges and Considerations: Data Privacy and Security: Transferring vehicle data to the cloud necessitates robust encryption and authentication mechanisms to safeguard sensitive data. Connectivity Reliability: Poor network coverage can undermine internet-dependent functionalities, urging manufacturers to ensure essential operations remain unaffected. System Complexity: Integrating cloud analysis and remote diagnostics requires intricate software and communication protocols, demanding reliability and compatibility with varied vehicle models. In essence, vehicle-cloud collaborative fault diagnosis innovatively augments EV maintenance, reliability, and user experiences. By capitalizing on cloud computing and data analysis, manufacturers and vehicle owners collaboratively guarantee optimal EV performance while curtailing maintenance costs and downtime.

## XII. CONCLUSION

The BMS plays a pivotal role in the efficient operation of BESS within EVs. This paper offers a comprehensive review of critical BMS aspects, with a primary focus on battery modeling, state estimation, and battery charging. The significance of accurate battery modeling and precise internal state estimation cannot be overstated, as they provide invaluable insights into operational conditions and enable the optimization of charging strategies. Nevertheless, the road to fully realizing the potential of BMS technology is not without its challenges, particularly in terms of validating these systems under real-world conditions. This paper identifies these challenges and underscores the importance of addressing them to facilitate the seamless integration of BMS into EVs. In light of this, the paper outlines promising future directions for BMS advancement. Foremost among these is the conception of a universal BMS, a concept that holds the potential to standardize BMS technology across various platforms and manufacturers. Furthermore, the integration of improved predictive techniques and hybridized intelligent algorithms emerges as a pathway to enhance the accuracy of BMS operations. Concurrently, the paper advocates for the development of effective prototype designs, an essential step toward translating theoretical advancements into practical, reliable solutions. Another intriguing avenue for BMS innovation lies in its virtualization. By creating virtual BMS frameworks, researchers and engineers can simulate a range of scenarios, facilitating more thorough testing and validation. As the paper points out, such virtualization could significantly expedite the refinement of

BMS technologies, thereby accelerating their adoption within the EV industry. It is abundantly clear that surmounting the current obstacles is imperative for the successful mainstream integration of EVs. The insights and recommendations presented in this research are of immense value to vehicle engineers and EV manufacturers, guiding them towards the development of safer, more efficient, and more reliable BMS systems. Looking to the future, the paper underscores the need for a dynamic, data-driven electro-thermal model. This innovative model holds promise for real-time status prediction, health diagnosis, and precise charging control. By harnessing the power of such a model, the EV industry can move closer to achieving its goals of enhanced operational efficiency, prolonged battery lifespan, and widespread EV adoption. In essence, this paper not only encapsulates the current state of BMS technology but also sets the stage for its evolution. By addressing challenges, suggesting forward-looking strategies, and highlighting the potential of novel approaches, the research serves as a guiding light for the ongoing development of BMS in the context of EVs.

## REFERENCES

- [1] Y. Khawaja, N. Shankar, I. Qiqieh, J. Alzubi, O. Alzubi, M. K. Nallakaruppan, and S. Padmanaban, "Battery management solutions for Li-ion batteries based on artificial intelligence," *Ain Shams Eng. J.*, Mar. 2023, Art. no. 102213.
- [2] S. S. Ravi and M. Aziz, "Utilization of electric vehicles for vehicle-to-grid services: Progress and perspectives," *Energies*, vol. 15, no. 2, p. 589, Jan. 2022.
- [3] K. Liu, K. Li, Q. Peng, and C. Zhang, "A brief review on key technologies in the battery management system of electric vehicles," *Frontiers Mech. Eng.*, vol. 14, no. 1, pp. 47–64, Mar. 2019.
- [4] M. A. Hannan, M. M. Hoque, A. Hussain, Y. Yusof, and P. J. Ker, "State-of-the-art and energy management system of lithium-ion batteries in electric vehicle applications: Issues and recommendations," *IEEE Access*, vol. 6, pp. 19362–19378, 2018.
- [5] R. Xiong, J. Cao, Q. Yu, H. He, and F. Sun, "Critical review on the battery state of charge estimation methods for electric vehicles," *IEEE Access*, vol. 6, pp. 1832–1843, 2018.
- [6] Y.-J. Ee, K.-S. Tey, K.-S. Lim, P. Shrivastava, S. B. R. S. Adnan, and H. Ahmad, "Lithium-ion battery state of charge (SoC) estimation with non-electrical parameter using uniform fiber Bragg grating (FBG)," *J. Energy Storage*, vol. 40, Aug. 2021, Art. no. 102704.
- [7] M. Lelie, T. Braun, M. Knips, H. Nordmann, F. Ringbeck, H. Zappen, and D. Sauer, "Battery management system hardware concepts: An overview," *Appl. Sci.*, vol. 8, no. 4, p. 534, Mar. 2018.
- [8] M. Uzair, G. Abbas, and S. Hosain, "Characteristics of battery management systems of electric vehicles with consideration of the active and passive cell balancing process," *World Electr. Vehicle J.*, vol. 12, no. 3, p. 120, Aug. 2021.
- [9] B. Balasingam, M. Ahmed, and K. Pattipati, "Battery management systems—Challenges and some solutions," *Energies*, vol. 13, no. 11, p. 2825, Jun. 2020.
- [10] S. Gold, "A PSPICE macromodel for lithium-ion batteries," in *Proc. 12th Annu. Battery Conf. Appl. Adv.*, Long Beach, CA, USA, 1997, pp. 215–222, doi: 10.1109/BCAA.1997.574106.
- [11] Y. Xing, E. W. M. Ma, K. L. Tsui, and M. Pecht, "Battery management systems in electric and hybrid vehicles," *Energies*, vol. 4, no. 11, pp. 1840–1857, 2011.
- [12] R. Yang, R. Xiong, H. He, H. Mu, and C. Wang, "A novel method on estimating the degradation and state of charge of lithium-ion batteries used for electrical vehicles," *Appl. Energy*, vol. 207, pp. 336–345, Dec. 2017.
- [13] S. Peng, C. Chen, H. Shi, and Z. Yao, "State of charge estimation of battery energy storage systems based on adaptive unscented Kalman filter with a noise statistics estimator," *IEEE Access*, vol. 5, pp. 13202–13212, 2017.

- [14] X. Hu, R. Xiong, and B. Egardt, "Model-based dynamic power assessment of lithium-ion batteries considering different operating conditions," *IEEE Trans. Ind. Informat.*, vol. 10, no. 3, pp. 1948–1959, Aug. 2014.
- [15] H. Yin, W. Zhou, M. Li, C. Ma, and C. Zhao, "An adaptive fuzzy logic-based energy management strategy on battery/ultracapacitor hybrid electric vehicles," *IEEE Trans. Transport. Electrific.*, vol. 2, no. 3, pp. 300–311, Sep. 2016.
- [16] M. Wadman, "Watching the teen brain grow," *Science*, vol. 359, no. 6371, pp. 13–14, Jan. 2018.
- [17] D. Linden and T. B. Reddy, *Handbook of Batteries*. New York, NY, USA: McGraw-Hill, 2004.
- [18] H. Zhang, Q. Miao, X. Zhang, and Z. Liu, "An improved unscented particle filter approach for lithium-ion battery remaining useful life prediction," *Microelectron. Rel.*, vol. 81, no. 24, pp. 288–298, Feb. 2018.
- [19] X. Feng, J. Li, M. Ouyang, L. Lu, J. Li, and X. He, "Using probability density function to evaluate the state of health of lithium-ion batteries," *J. Power Sources*, vol. 232, pp. 209–218, Jun. 2013.
- [20] N. Nitta, F. Wu, J. T. Lee, and G. Yushin, "Li-ion battery materials: Present and future," *Mater. Today*, vol. 18, no. 5, pp. 252–264, Jun. 2015.
- [21] J. R. Selman, S. Al Hallaj, I. Uchida, and Y. Hirano, "Cooperative research on safety fundamentals of lithium batteries," *J. Power Sources*, vols. 97–98, pp. 726–732, Jul. 2001.
- [22] H. Vikström, S. Davidsson, and M. Höök, "Lithium availability and future production outlooks," *Appl. Energy*, vol. 110, pp. 252–266, Oct. 2013.
- [23] M. Adaikkappan and N. Sathiyamoorthy, "Modeling, state of charge estimation, and charging of lithium-ion battery in electric vehicle: A review," *Int. J. Energy Res.*, vol. 46, no. 3, pp. 2141–2165, Mar. 2022.
- [24] M. Doyle, T. F. Fuller, and J. Newman, "Modeling of galvanostatic charge and discharge of the lithium/polymer/insertion cell," *J. Electrochem. Soc.*, vol. 140, no. 6, pp. 1526–1533, 1993.
- [25] D. Di Domenico, G. Fiengo, and A. Stefanopoulou, "Lithium-ion battery state of charge estimation with a Kalman Filter based on an electrochemical model," presented at the IEEE Int. Conf. Control Appl., Sep. 2008.
- [26] R. Ahmed, M. El Sayed, I. Arasaratnam, J. Tjong, and S. Habibi, "Reduced-order electrochemical model parameters identification and state of charge estimation for healthy and aged Li-ion batteries—Part II: Aged battery model and state of charge estimation," *IEEE J. Emerg. Sel. Topics Power Electron.*, vol. 2, no. 3, pp. 678–690, Sep. 2014.
- [27] R. Ahmed, M. El Sayed, I. Arasaratnam, J. Tjong, and S. Habibi, "Reduced-order electrochemical model parameters identification and SOC estimation for healthy and aged Li-ion batteries Part I: Parameterization model development for healthy batteries," *IEEE J. Emerg. Sel. Topics Power Electron.*, vol. 2, no. 3, pp. 659–677, Sep. 2014.
- [28] X. Han, M. Ouyang, L. Lu, and J. Li, "Simplification of physics-based electrochemical model for lithium ion battery on electric vehicle. Part I: Diffusion simplification and single particle model," *J. Power Sources*, vol. 278, pp. 802–813, Mar. 2015.
- [29] C. Zou, C. Manzie, and D. Nestic, "A framework for simplification of PDE-based lithium-ion battery models," *IEEE Trans. Control Syst. Technol.*, vol. 24, no. 5, pp. 1594–1609, Sep. 2016.
- [30] M. Sitterly, L. Y. Wang, G. G. Yin, and C. Wang, "Enhanced identification of battery models for real-time battery management," *IEEE Trans. Sustain. Energy*, vol. 2, no. 3, pp. 300–308, Jul. 2011.
- [31] M. Chen and G. A. Rincon-Mora, "Accurate electrical battery model capable of predicting runtime and I–V performance," *IEEE Trans. Energy Convers.*, vol. 21, no. 2, pp. 504–511, Jun. 2006.
- [32] K. D. Stetzel, L. L. Aldrich, M. S. Trimboli, and G. L. Plett, "Electrochemical state and internal variables estimation using a reduced-order physics-based model of a lithium-ion cell and an extended Kalman filter," *J. Power Sources*, vol. 278, pp. 490–505, Mar. 2015.
- [33] S. Nejad, D. T. Gladwin, and D. A. Stone, "A systematic review of lumped-parameter equivalent circuit models for real-time estimation of lithium-ion battery states," *J. Power Sources*, vol. 316, pp. 183–196, Jun. 2016.
- [34] Z. Xu, S. Gao, and S. Yang, "LiFePO<sub>4</sub> battery state of charge estimation based on the improved Thevenin equivalent circuit model and Kalman filtering," *J. Renew. Sustain. Energy*, vol. 8, no. 2, Mar. 2016, Art. no. 024103.
- [35] L. Siguang and Z. Chengning, "Study on battery management system and lithium-ion battery," in *Proc. Int. Conf. Comput. Autom. Eng. (ICCAE)*, Mar. 2009, pp. 218–222.
- [36] J. Meng, G. Luo, M. Ricco, M. Swierczynski, D.-I. Stroe, and R. Teodorescu, "Overview of lithium-ion battery modeling methods for state-of-charge estimation in electrical vehicles," *Appl. Sci.*, vol. 8, no. 5, p. 659, Apr. 2018.
- [37] N. Omar, D. Widanage, M. A. Monem, Y. Firouz, O. Hegazy, P. Van den Bossche, T. Coosemans, and J. Van Mierlo, "Optimization of an advanced battery model parameter minimization tool and development of a novel electrical model for lithium-ion batteries," *Int. Trans. Electr. Energy Syst.*, vol. 24, no. 12, pp. 1747–1767, Dec. 2014.
- [38] X. Lai, W. Gao, Y. Zheng, M. Ouyang, J. Li, X. Han, and L. Zhou, "A comparative study of global optimization methods for parameter identification of different equivalent circuit models for Li-ion batteries," *Electrochimica Acta*, vol. 295, pp. 1057–1066, Feb. 2019.
- [39] A. Fotouhi, D. J. Auger, K. Propp, and S. Longo, "Accuracy versus simplicity in online battery model identification," *IEEE Trans. Syst., Man, Cybern. Syst.*, vol. 48, no. 2, pp. 195–206, Feb. 2018.
- [40] A. Fotouhi, K. Propp, and D. J. Auger, "Electric vehicle battery model identification and state of charge estimation in real world driving cycles," in *Proc. 7th Comput. Sci. Electron. Eng. Conf. (CEECE)*, U.K.: Univ. of Essex, Sep. 2015, pp. 243–248.
- [41] L. W. Yao, J. A. Aziz, P. Y. Kong, and N. R. N. Idris, "Modeling of lithium-ion battery using MATLAB/simulink," in *Proc. 39th Annu. Conf. IEEE Ind. Electron. Soc. (IECON)*, Nov. 2013, pp. 1729–1734.
- [42] Y. Hu and Y.-Y. Wang, "Two time-scaled battery model identification with application to battery state estimation," *IEEE Trans. Control Syst. Technol.*, vol. 23, no. 3, pp. 1180–1188, May 2015.
- [43] K. Yang, Y. Tang, and Z. Zhang, "Parameter identification and state-of-charge estimation for lithium-ion batteries using separated time scales and extended Kalman filter," *Energies*, vol. 14, pp. 1–15, Feb. 2021.
- [44] A. Wang, X. Jin, Y. Li, and N. Li, "LiFePO<sub>4</sub> battery modeling and SOC estimation algorithm," in *Proc. 29th Chin. Control Decis. Conf. (CCDC)*, Chongqing, China, May 2017, pp. 7574–7578.
- [45] Y. Cao, R. C. Kroeze, and P. T. Krein, "Multi-timescale parametric electrical battery model for use in dynamic electric vehicle simulations," *IEEE Trans. Transport. Electrific.*, vol. 2, no. 4, pp. 432–442, Dec. 2016.
- [46] C. Zhang, W. Allafi, Q. Dinh, P. Ascencio, and J. Marco, "Online estimation of battery equivalent circuit model parameters and state of charge using decoupled least squares technique," *Energy*, vol. 142, pp. 678–688, Jan. 2018.
- [47] K. Thirugnanam, T. P. E. R. Joy, M. Singh, and P. Kumar, "Mathematical modeling of Li-ion battery using genetic algorithm approach for V2G applications," *IEEE Trans. Energy Convers.*, vol. 29, no. 2, pp. 332–343, Jun. 2014.
- [48] Y. Boujoudar, H. Elmoussaoui, and T. Lamhamdi, "Lithium-ion batteries modeling and state of charge estimation using artificial neural network," *Int. J. Electr. Comput. Eng.*, vol. 9, no. 5, p. 3415, Oct. 2019.
- [49] M. A. Awadallah and B. Venkatesh, "Accuracy improvement of SOC estimation in lithium-ion batteries," *J. Energy Storage*, vol. 6, pp. 95–104, May 2016.
- [50] P. Khumprom and N. Yodo, "A data-driven predictive prognostic model for Li-ion batteries based on a deep learning algorithm," *Energies*, vol. 12, no. 4, p. 660, Feb. 2019.
- [51] V. Klass, M. Behm, and G. Lindbergh, "Capturing lithium-ion battery dynamics with support vector machine-based battery model," *J. Power Sources*, vol. 298, pp. 92–101, Dec. 2015.
- [52] W. Junping, C. Quanshi, and C. Binggang, "Support vector machine based battery model for electric vehicles," *Energy Convers. Manage.*, vol. 47, nos. 7–8, pp. 858–864, May 2006.
- [53] C. Weng, J. Sun, and H. Peng, "Model parametrization and adaptation based on the invariance of support vectors with applications to battery state-of-health monitoring," *IEEE Trans. Veh. Technol.*, vol. 64, no. 9, pp. 3908–3917, Sep. 2015.
- [54] Z.-S. Hou and J.-X. Xu, "On data-driven control theory: The state of the art and perspective," *Acta Automatica Sinica*, vol. 35, no. 6, pp. 650–667, Oct. 2009.
- [55] J. N. Hu, J. J. Hu, H. B. Lin, X. P. Li, C. L. Jiang, X. H. Qiu, and W. S. Li, "State-of-charge estimation for battery management system using optimized support vector machine for regression," *J. Power Sources*, vol. 269, pp. 682–693, Dec. 2014.
- [56] G. dos Reis, C. Strange, M. Yadav, and S. Li, "Lithium-ion battery data and where to find it," *Energy AI*, vol. 5, Sep. 2021, Art. no. 100081.
- [57] H. B. Sassi, F. Errahimi, N. Es-Sbai, and C. Alaoui, "Comparative study of ANN/KF for on-board SOC estimation for vehicular applications," *J. Energy Storage*, vol. 25, Oct. 2019, Art. no. 100822.
- [58] M. A. Hannan, M. S. H. Lipu, A. Hussain, M. H. Saad, and A. Ayob, "Neural network approach for estimating state of charge of lithium-ion battery using backtracking search algorithm," *IEEE Access*, vol. 6, pp. 10069–10079, 2018.

- [59] L. Zhang, M. Zheng, D. Du, Y. Li, M. Fei, Y. Guo, and K. Li, "State-of-charge estimation of lithium-ion battery pack based on improved RBF neural networks," *Complexity*, vol. 2020, pp. 1–10, Nov. 2020.
- [60] D. Cui, B. Xia, R. Zhang, Z. Sun, Z. Lao, W. Wang, W. Sun, Y. Lai, and M. Wang, "A novel intelligent method for the state of charge estimation of lithium-ion batteries using a discrete wavelet transform-based wavelet neural network," *Energies*, vol. 11, no. 4, p. 995, Apr. 2018.
- [61] V. M. Nagulapati, H. Lee, D. Jung, S. S. Paramanathan, B. Brigljevic, Y. Choi, and H. Lim, "A novel combined multi-battery dataset based approach for enhanced prediction accuracy of data driven prognostic models in capacity estimation of lithium ion batteries," *Energy AI*, vol. 5, Sep. 2021, Art. no. 100089, doi: [10.1016/j.egyai.2021.100089](https://doi.org/10.1016/j.egyai.2021.100089).
- [62] Z. Deng, X. Hu, X. Lin, Y. Che, L. Xu, and W. Guo, "Data-driven state of charge estimation for lithium-ion battery packs based on Gaussian process regression," *Energy*, vol. 205, Aug. 2020, Art. no. 118000.
- [63] I. Babaeiyazdi, A. Rezaei-Zare, and S. Shokrzadeh, "State of charge prediction of EV Li-ion batteries using EIS: A machine learning approach," *Energy*, vol. 223, May 2021, Art. no. 120116.
- [64] J. Du, Z. Liu, and Y. Wang, "State of charge estimation for Li-ion battery based on model from extreme learning machine," *Control Eng. Pract.*, vol. 26, no. 1, pp. 11–19, May 2014.
- [65] M. S. H. Lipu, M. A. Hannan, A. Hussain, M. H. Saad, A. Ayob, and M. N. Uddin, "Extreme learning machine model for state-of-charge estimation of lithium-ion battery using gravitational search algorithm," *IEEE Trans. Ind. Appl.*, vol. 55, no. 4, pp. 4225–4234, Jul. 2019.
- [66] Z. Wu and P. Christofides, "Economic machine-learning-based predictive control of nonlinear systems," *Mathematics*, vol. 7, no. 6, p. 494, Jun. 2019.
- [67] M. M. Hasan, S. A. Pourmousavi, A. J. Ardakani, and T. K. Saha, "A data-driven approach to estimate battery cell temperature using a nonlinear autoregressive exogenous neural network model," *J. Energy Storage*, vol. 32, Dec. 2020, Art. no. 101879.
- [68] C. Li, F. Xiao, and Y. Fan, "An approach to state of charge estimation of lithium-ion batteries based on recurrent neural networks with gated recurrent unit," *Energies*, vol. 12, no. 9, p. 1592, Apr. 2019, doi: [10.3390/en12091592](https://doi.org/10.3390/en12091592).
- [69] C. Zhang, Y. Zhu, G. Dong, and J. Wei, "Data-driven lithium-ion battery states estimation using neural networks and particle filtering," *Int. J. Energy Res.*, vol. 43, no. 14, pp. 8230–8241, Aug. 2019, doi: [10.1002/er.4820](https://doi.org/10.1002/er.4820).
- [70] F. Yang, S. Zhang, W. Li, and Q. Miao, "State-of-charge estimation of lithium-ion batteries using LSTM and UKF," *Energy*, vol. 201, Jun. 2020, Art. no. 117664.
- [71] M. Naumann, F. B. Spingler, and A. Jossen, "Analysis and modeling of cycle aging of a commercial LiFePO<sub>4</sub>/graphite cell," *J. Power Sources*, vol. 451, Mar. 2020, Art. no. 227666.
- [72] S. B. Sarmah, P. Kalita, A. Garg, X.-D. Niu, X.-W. Zhang, X. Peng, and D. Bhattacharjee, "A review of state of health estimation of energy storage systems: Challenges and possible solutions for futuristic applications of Li-ion battery packs in electric vehicles," *J. Electrochem. Energy Convers. Storage*, vol. 16, no. 4, Nov. 2019, Art. no. 040801.
- [73] F. Richter, S. Kjelstrup, P. J. S. Vie, and O. S. Burheim, "Thermal conductivity and internal temperature profiles of Li-ion secondary batteries," *J. Power Sources*, vol. 359, pp. 592–600, Aug. 2017.
- [74] S. Abada, G. Marlair, A. Lecocq, M. Petit, V. Sauvart-Moynot, and F. Huet, "Safety focused modeling of lithium-ion batteries: A review," *J. Power Sources*, vol. 306, pp. 178–192, Feb. 2016.
- [75] X. Lin, H. E. Perez, S. Mohan, J. B. Siegel, A. G. Stefanopoulou, Y. Ding, and M. P. Castanier, "A lumped-parameter electro-thermal model for cylindrical batteries," *J. Power Sources*, vol. 257, pp. 1–11, Jul. 2014.
- [76] H. E. Perez, X. Hu, S. Dey, and S. J. Moura, "Optimal charging of Li-ion batteries with coupled electro-thermal-aging dynamics," *IEEE Trans. Veh. Technol.*, vol. 66, no. 9, pp. 7761–7770, Sep. 2017.
- [77] S. Dey and B. Ayalew, "Real-time estimation of lithium-ion concentration in both electrodes of a lithium-ion battery cell utilizing electrochemical-thermal coupling," *J. Dyn. Syst., Meas., Control*, vol. 139, no. 3, Mar. 2017, Art. no. 031007.
- [78] S. Goutam, A. Nikolian, J. Jagueumont, J. Smekens, N. Omar, P. Van Dan Bossche, and J. Van Mierlo, "Three-dimensional electro-thermal model of Li-ion pouch cell: Analysis and comparison of cell design factors and model assumptions," *Appl. Thermal Eng.*, vol. 126, pp. 796–808, Nov. 2017.
- [79] J. Jiang, H. Ruan, B. Sun, W. Zhang, W. Gao, L. Y. Wang, and L. Zhang, "A reduced low-temperature electro-thermal coupled model for lithium-ion batteries," *Appl. Energy*, vol. 177, pp. 804–816, Sep. 2016.
- [80] S. Basu, K. S. Hariharan, S. M. Kolake, T. Song, D. K. Sohn, and T. Yeo, "Coupled electrochemical thermal modelling of a novel Li-ion battery pack thermal management system," *Appl. Energy*, vol. 181, pp. 1–13, Nov. 2016.
- [81] V. Pop, H. J. Bergveld, D. Danilov, P. P. L. Regtien, and P. H. L. Notten, *Battery Management Systems: Accurate State-of-Charge Indication for Battery-Powered Applications*, vol. 9. Dordrecht, The Netherlands: Springer, 2008, doi: [10.1007/978-1-4020-6945-1](https://doi.org/10.1007/978-1-4020-6945-1).
- [82] R. Xiong, J. Tian, H. Mu, and C. Wang, "A systematic model-based degradation behavior recognition and health monitoring method for lithium-ion batteries," *Appl. Energy*, vol. 207, Dec. 2017, Art. no. 367378.
- [83] M. A. Hannan, M. S. H. Lipu, A. Hussain, and A. Mohamed, "A review of lithium-ion battery state of charge estimation and management system in electric vehicle applications: Challenges and recommendations," *Renew. Sustain. Energy Rev.*, vol. 78, pp. 834–854, Oct. 2017.
- [84] P. Manoharan, R. Mohankumar, K. Karthick, and R. Sowmya, "SoC estimation and monitoring of Li-ion cell using Kalman-filter algorithm," *Indonesian J. Electr. Eng. Informat.*, vol. 6, no. 4, pp. 418–427, Dec. 2018.
- [85] F. Asghar, M. Talha, S. H. Kim, and I.-H. Ra, "Simulation study on battery state of charge estimation using Kalman filter," *J. Adv. Comput. Intell. Intell. Informat.*, vol. 20, no. 6, pp. 861–866, Nov. 2016, doi: [10.20965/jaciii.2016.p0861](https://doi.org/10.20965/jaciii.2016.p0861).
- [86] W. Wang and J. Mu, "State of charge estimation for lithium-ion battery in electric vehicle based on Kalman filter considering model error," *IEEE Access*, vol. 7, pp. 29223–29235, 2019, doi: [10.1109/ACCESS.2019.2895377](https://doi.org/10.1109/ACCESS.2019.2895377).
- [87] G. L. Plett, "Extended Kalman filtering for battery management systems of LiPB-based HEV battery packs: Part 3. State and parameter estimation," *J. Power Sources*, vol. 134, pp. 277–292, Aug. 2004, doi: [10.1016/j.jpowsour.2004.02.033](https://doi.org/10.1016/j.jpowsour.2004.02.033).
- [88] C. Taborelli and S. Onori, "State of charge estimation using extended Kalman filters for battery management system," presented at the IEEE Int. Electr. Vehicle Conf. (IEVC), 2014, doi: [10.1109/IEVC.2014.7056126](https://doi.org/10.1109/IEVC.2014.7056126).
- [89] Z. Li, Z. Peng, W. Zhifu, S. Qiang, and R. Yanan, "State of charge estimation for Li-ion battery based on extended Kalman filter," *Energy Proc.*, vol. 105, no. 4, pp. 3515–3520, 2017, doi: [10.1016/j.egypro.2017.03.806](https://doi.org/10.1016/j.egypro.2017.03.806).
- [90] M. Al-Gabalawy, N. S. Hosny, J. A. Dawson, and A. I. Omar, "State of charge estimation of a Li-ion battery based on extended Kalman filtering and sensor bias," *Int. J. Energy Res.*, vol. 45, no. 5, pp. 6708–6726, Apr. 2021.
- [91] W. He, N. Williard, C. Chen, and M. Pecht, "State of charge estimation for electric vehicle batteries using unscented Kalman filtering," *Microelectron. Rel.*, vol. 53, no. 6, pp. 840–847, Jun. 2013.
- [92] S. Santhanagopalan and R. E. White, "State of charge estimation using an unscented filter for high power lithium ion cells," *Int. J. Energy Res.*, vol. 34, no. 2, pp. 152–163, Feb. 2010.
- [93] F. Zhang, G. Liu, and L. Fang, "Battery state estimation using unscented Kalman filter," in *Proc. IEEE Int. Conf. Robot. Autom.*, vol. 3, pp. 1863–1868, May 2009.
- [94] N. Peng, S. Zhang, X. Guo, and X. Zhang, "Online parameters identification and state of charge estimation for Li-ion batteries using improved adaptive dual unscented Kalman filter," *Int. J. Energy Res.*, vol. 45, no. 1, pp. 975–990, 2021.
- [95] X. Chen, X. Chen, and X. Chen, "A novel framework for lithium-ion battery state of charge estimation based on Kalman filter Gaussian process regression," *Int. J. Energy Res.*, vol. 45, no. 9, pp. 13238–13249, Jul. 2021.
- [96] K. Lim, H. A. Bastawrous, V.-H. Duong, K. W. See, P. Zhang, and S. X. Dou, "Fading Kalman filter-based real-time state of charge estimation in LiFePO<sub>4</sub> battery-powered electric vehicles," *Appl. Energy*, vol. 169, pp. 40–48, May 2016.
- [97] Y. Yang, N. Cui, C. Wang, M. Liu, and R. Gao, "SOC estimation of lithium-ion battery based on new adaptive fading extended Kalman filter," in *Proc. Chin. Autom. Congr. (CAC)*, Oct. 2017, pp. 5630–5634.
- [98] J. Peng, J. Luo, H. He, and B. Lu, "An improved state of charge estimation method based on cubature Kalman filter for lithium-ion batteries," *Appl. Energy*, vol. 253, Nov. 2019, Art. no. 113520.
- [99] Y. Shen, "Adaptive online state-of-charge determination based on neuro-controller and neural network," *Energy Convers. Manage.*, vol. 51, no. 5, pp. 1093–1098, May 2010.
- [100] A. J. Salkind, C. Fennie, P. Singh, T. Atwater, and D. E. Reisner, "Determination of state-of-charge and state-of-health of batteries by fuzzy logic methodology," *J. Power Sources*, vol. 80, nos. 1–2, pp. 293–300, Jul. 1999.

- [101] P. Singh, R. Vinjamuri, X. Wang, and D. Reisner, "Design and implementation of a fuzzy logic-based state-of-charge meter for Li-ion batteries used in portable defibrillators," *J. Power Sources*, vol. 162, no. 2, pp. 829–836, Nov. 2006.
- [102] T. Hansen and C.-J. Wang, "Support vector based battery state of charge estimator," *J. Power Sources*, vol. 141, no. 2, pp. 351–358, Mar. 2005.
- [103] W. Junping, C. Quanshi, and C. Binggang, "Support vector machine based battery model for electric vehicles," *Energy Convers. Manage.*, vol. 47, nos. 7–8, pp. 858–864, May 2006.
- [104] J. Du, Z. Liu, and Y. Wang, "State of charge estimation for Li-ion battery based on model from extreme learning machine," *Control Eng. Pract.*, vol. 26, pp. 11–19, May 2014, doi: [10.1016/j.conengprac.2013.12.014](https://doi.org/10.1016/j.conengprac.2013.12.014).
- [105] A. Wang, X. Jin, Y. Li, and N. Li, "LiFePO<sub>4</sub> battery modeling and SOC estimation algorithm," in *Proc. 29th Chin. Control Decis. Conf. (CCDC)*, Chongqing, China, May 2017, pp. 7574–7578.
- [106] M. F. Samadi and M. Saif, "State-space modeling and observer design of Li-ion batteries using Takagi–Sugeno fuzzy system," *IEEE Trans. Control Syst. Technol.*, vol. 25, no. 1, pp. 301–308, Jan. 2017.
- [107] H. Dai, P. Guo, X. Wei, Z. Sun, and J. Wang, "ANFIS (adaptive neuro-fuzzy inference system) based online SOC (state of charge) correction considering cell divergence for the EV (electric vehicle) traction batteries," *Energy*, vol. 80, pp. 350–360, Feb. 2015.
- [108] M. Ismail, R. Dlyma, A. Elrakaybi, R. Ahmed, and S. Habibi, "Battery state of charge estimation using an artificial neural network," in *Proc. IEEE Transp. Electrific. Conf. Expo (ITEC)*, Jun. 2017, pp. 342–349.
- [109] X. Fan, W. Zhang, C. Zhang, A. Chen, and F. An, "SOC estimation of Li-ion battery using convolutional neural network with U-Net architecture," *Energy*, vol. 256, Oct. 2022, Art. no. 124612.
- [110] G. Taş, A. Uysal, and C. Bal, "A new lithium polymer battery dataset with different discharge levels: SOC estimation of lithium polymer batteries with different convolutional neural network models," *Arabian J. Sci. Eng.*, vol. 48, no. 5, pp. 6873–6888, May 2023.
- [111] A. Bhattacharjee, A. Verma, S. Mishra, and T. K. Saha, "Estimating state of charge for xEV batteries using 1D convolutional neural networks and transfer learning," *IEEE Trans. Veh. Technol.*, vol. 70, no. 4, pp. 3123–3135, Apr. 2021.
- [112] H.-T. Lin, T.-J. Liang, and S.-M. Chen, "Estimation of battery state of health using probabilistic neural network," *IEEE Trans. Ind. Informat.*, vol. 9, no. 2, pp. 679–685, May 2013.
- [113] Y. Xu, M. Hu, A. Zhou, Y. Li, S. Li, C. Fu, and C. Gong, "State of charge estimation for lithium-ion batteries based on adaptive dual Kalman filter," *Appl. Math. Model.*, vol. 77, pp. 1255–1272, Jan. 2020.
- [114] J. Yang, B. Xia, Y. Shang, W. Huang, and C. C. Mi, "Adaptive state-of-charge estimation based on a split battery model for electric vehicle applications," *IEEE Trans. Veh. Technol.*, vol. 66, no. 12, pp. 10889–10898, Dec. 2017.
- [115] S. Xie, R. Xiong, Y. Zhang, and H. He, "The estimation of state of charge for power battery packs used in hybrid electric vehicle," *Energy Proc.*, vol. 105, pp. 2678–2683, May 2017, doi: [10.1016/j.egypro.2017.03.774](https://doi.org/10.1016/j.egypro.2017.03.774).
- [116] L. Xue, J. Jiuchun, Z. Caiping, Z. Weige, and S. Bingxiang, "Effects analysis of model parameters uncertainties on battery SOC estimation using H-infinity observer," in *Proc. IEEE 23rd Int. Symp. Ind. Electron. (ISIE)*, Jun. 2014, pp. 1647–1653.
- [117] R. Xiong, F. Sun, X. Gong, and H. He, "Adaptive state of charge estimator for Li-ion cells series battery pack in electric vehicles," *J. Power Sources*, vol. 242, Nov. 2013, Art. no. 699713.
- [118] F. Sun and R. Xiong, "A novel dual-scale cell state-of-charge estimation approach for series-connected battery pack used in electric vehicles," *J. Power Sources*, vol. 274, pp. 582–594, Jan. 2015.
- [119] G. B. Alliance, "A vision for a sustainable battery value chain in 2030: Unlocking the full potential to power sustainable development and climate change mitigation," World Economic Forum, Geneva, Switzerland, Tech. Rep., 2019, pp. 1–52. [Online]. Available: [https://www3.weforum.org/docs/WEF\\_A\\_Vision\\_for\\_a\\_Sustainable\\_Battery\\_Value\\_Chain\\_in\\_2030\\_Report.pdf](https://www3.weforum.org/docs/WEF_A_Vision_for_a_Sustainable_Battery_Value_Chain_in_2030_Report.pdf)
- [120] M. A. Hannan, M. S. H. Lipu, A. Hussain, and A. Mohamed, "A review of lithium-ion battery state of charge estimation and management system in electric vehicle applications: Challenges and recommendations," *Renew. Sustain. Energy Rev.*, vol. 78, pp. 834–854, Oct. 2017.
- [121] T. Yu, J. Fu, R. Cai, A. Yu, and Z. Chen, "Nonprecious electrocatalysts for Li-air and Zn-air batteries: Fundamentals and recent advances," *IEEE Nanotechnol. Mag.*, vol. 11, no. 3, pp. 29–55, Sep. 2017.
- [122] G. Li, X. Lu, J. Y. Kim, K. D. Meinhardt, H. J. Chang, N. L. Canfield, and V. L. Sprenkle, "Advanced intermediate temperature sodium–nickel chloride batteries with ultra-high energy density," *Nature Commun.*, vol. 7, no. 1, pp. 1–6, Feb. 2016.
- [123] S. Wei, S. Xu, A. Agrawal, S. Choudhury, Y. Lu, Z. Tu, L. Ma, and L. A. Archer, "A stable room-temperature sodium–sulfur battery," *Nature Commun.*, vol. 7, no. 1, 2016, Art. no. 11722.
- [124] X. Xu, D. Zhou, X. Qin, K. Lin, F. Kang, B. Li, D. Shanmukaraj, T. Rojo, M. Armand, and G. Wang, "A room-temperature sodium–sulfur battery with high capacity and stable cycling performance," *Nature Commun.*, vol. 9, no. 1, Sep. 2018, Art. no. 3870.
- [125] L.-R. Chen, R. C. Hsu, and C.-S. Liu, "A design of a grey-predicted Li-ion battery charge system," *IEEE Trans. Ind. Electron.*, vol. 55, no. 10, pp. 3692–3701, Oct. 2008.
- [126] K. Liu, K. Li, Z. Yang, C. Zhang, and J. Deng, "Battery optimal charging strategy based on a coupled thermoelectric model," in *Proc. IEEE Congr. Evol. Comput. (CEC)*, Jul. 2016, pp. 5084–5091, doi: [10.1109/CEC.2016.7748334](https://doi.org/10.1109/CEC.2016.7748334).
- [127] Y.-H. Liu, J.-H. Teng, and Y.-C. Lin, "Search for an optimal rapid charging pattern for lithium-ion batteries using ant colony system algorithm," *IEEE Trans. Ind. Electron.*, vol. 52, no. 5, pp. 1328–1336, Oct. 2005.
- [128] C.-H. Lee, M.-Y. Chen, S.-H. Hsu, and J.-A. Jiang, "Implementation of an SOC-based four-stage constant current charger for Li-ion batteries," *J. Energy Storage*, vol. 18, pp. 528–537, Aug. 2018.
- [129] H. Min, W. Sun, X. Li, D. Guo, Y. Yu, T. Zhu, and Z. Zhao, "Research on the optimal charging strategy for Li-ion batteries based on multi-objective optimization," *Energies*, vol. 10, no. 5, p. 709, May 2017.
- [130] J. Sun, Q. Ma, R. Liu, T. Wang, and C. Tang, "A novel multiobjective charging optimization method of power lithium-ion batteries based on charging time and temperature rise," *Int. J. Energy Res.*, vol. 43, no. 13, pp. 7672–7681, Jul. 2019.
- [131] Y. Li, K. Li, Y. Xie, J. Liu, C. Fu, and B. Liu, "Optimized charging of lithium-ion battery for electric vehicles: Adaptive multistage constant current–constant voltage charging strategy," *Renew. Energy*, vol. 146, pp. 2688–2699, Feb. 2020, doi: [10.1016/j.renene.2019.08.077](https://doi.org/10.1016/j.renene.2019.08.077).
- [132] C. Zhang, J. Jiang, Y. Gao, W. Zhang, Q. Liu, and X. Hu, "Charging optimization in lithium-ion batteries based on temperature rise and charge time," *Appl. Energy*, vol. 194, pp. 569–577, May 2017.
- [133] Y. Li, K. Li, Y. Xie, B. Liu, J. Liu, J. Zheng, and W. Li, "Optimization of charging strategy for lithium-ion battery packs based on complete battery pack model," *J. Energy Storage*, vol. 37, May 2021, Art. no. 102466.
- [134] X. Wu, W. Shi, and J. Du, "Multi-objective optimal charging method for Li-ion batteries," *Energies*, vol. 10, no. 9, p. 1271, 2017.
- [135] K. Liu, K. Li, H. Ma, J. Zhang, and Q. Peng, "Multi-objective optimization of charging patterns for lithium-ion battery management," *Energy Convers. Manage.*, vol. 159, pp. 151–162, Mar. 2018.
- [136] K. Liu, C. Zou, K. Li, and T. Wik, "Charging pattern optimization for lithium-ion batteries with an electrothermal-aging model," *IEEE Trans. Ind. Informat.*, vol. 14, no. 12, pp. 5463–5474, Dec. 2018.
- [137] J. Liu, Q. Duan, H. Chen, J. Sun, and Q. Wang, "An optimal multistage charge strategy for commercial lithium ion batteries," *Sustain. Energy Fuels*, vol. 2, no. 8, pp. 1726–1736, 2018.
- [138] X. Wu, C. Hu, J. Du, and J. Sun, "Multistage CC-CV charge method for Li-ion battery," *Math. Problems Eng.*, vol. 2015, pp. 1–10, 2015.
- [139] Y. Liu, M. Xu, Z. Xu, and X. Wang, "A study of fast charging of Li-ion battery with pulsed current," in *Proc. ASME Int. Mech. Eng. Congr. Expo. (IMECE)*, 2019, p. 13, doi: [10.1115/IMECE2019-10375](https://doi.org/10.1115/IMECE2019-10375).
- [140] H. Fang, C. Depcik, and V. Lvovich, "Optimal pulse-modulated lithium-ion battery charging: Algorithms and simulation," *J. Energy Storage*, vol. 15, pp. 359–367, Feb. 2018.
- [141] S. O. Yong and N. A. Rahim, "Development of on-off duty cycle control with zero computational algorithm for CC-CV Li ion battery charger," in *Proc. IEEE Conf. Clean Energy Technol. (CEAT)*, Langkawi, Malaysia, Nov. 2013, pp. 422–426.
- [142] A. Abdollahi, X. Han, G. V. Avvari, N. Raghunathan, B. Balasingam, K. R. Pattipati, and Y. Bar-Shalom, "Optimal battery charging, Part I: Minimizing time-to-charge, energy loss, and temperature rise for OCV-resistance battery model," *J. Power Sources*, vol. 303, pp. 388–398, Jan. 2016.
- [143] G.-C. Hsieh, L.-R. Chen, and K.-S. Huang, "Fuzzy-controlled Li-ion battery charge system with active state-of-charge controller," *IEEE Trans. Ind. Electron.*, vol. 48, no. 3, pp. 585–593, Jun. 2001.

- [144] K. Liu, K. Li, Z. Yang, C. Zhang, and J. Deng, "An advanced lithium-ion battery optimal charging strategy based on a coupled thermoelectric model," *Electrochim. Acta*, vol. 225, pp. 330–344, Jan. 2017.
- [145] L. He, E. Kim, and K. G. Shin, "Aware charging of lithium-ion battery cells," in *Proc. ACM/IEEE 7th Int. Conf. Cyber-Physical Syst. (ICCPs)*, Vienna, Austria, Apr. 2016, pp. 1–10.
- [146] L.-R. Chen, "PLL-based battery charge circuit topology," *IEEE Trans. Ind. Electron.*, vol. 51, no. 6, pp. 1344–1346, Dec. 2004.
- [147] L.-R. Chen, J.-J. Chen, N.-Y. Chu, and G.-Y. Han, "Current-pumped battery charger," *IEEE Trans. Ind. Electron.*, vol. 55, no. 6, pp. 2482–2488, Jun. 2008.
- [148] H. Asadi, S. H. A. Kaboli, A. Mohammadi, and M. Oladazimi, "Fuzzy-control-based five-step Li-ion battery charger by using AC impedance technique," in *Proc. 4th Int. Conf. Mach. Vis. (ICMV)*, 2012, Art. no. 834939.
- [149] S.-C. Wang, Y.-L. Chen, Y.-H. Liu, and Y.-S. Huang, "A fast-charging pattern search for Li-ion batteries with fuzzy-logic-based Taguchi method," in *Proc. IEEE 10th Conf. Ind. Electron. Appl. (ICIEA)*, Auckland, New Zealand, Jun. 2015, pp. 855–859.
- [150] C.-L. Liu, S.-C. Wang, S.-S. Chiang, Y.-H. Liu, and C.-H. Ho, "PSO-based fuzzy logic optimization of dual performance characteristic indices for fast charging of lithium-ion batteries," in *Proc. IEEE 10th Int. Conf. Power Electron. Drive Syst. (PEDS)*, Apr. 2013, pp. 474–479.
- [151] S.-C. Wang and Y.-H. Liu, "A PSO-based fuzzy-controlled searching for the optimal charge pattern of Li-ion batteries," *IEEE Trans. Ind. Electron.*, vol. 62, no. 5, pp. 2983–2993, May 2015.
- [152] Y.-H. Liu, C.-H. Hsieh, and Y.-F. Luo, "Search for an optimal five-step charging pattern for Li-ion batteries using consecutive orthogonal arrays," *IEEE Trans. Energy Convers.*, vol. 26, no. 2, pp. 654–661, Jun. 2011.
- [153] T. T. Vo, X. Chen, W. Shen, and A. Kapoor, "New charging strategy for lithium-ion batteries based on the integration of Taguchi method and state of charge estimation," *J. Power Sources*, vol. 273, pp. 413–422, Jan. 2015.
- [154] W. Liu, X. Sun, H. Wu, Z. He, and G. Yang, "A multistage current charging method for Li-ion battery bank considering balance of internal consumption and charging speed," in *Proc. IEEE 8th Int. Power Electron. Motion Control Conf. (IPEMC-ECCE Asia)*, Hefei, China, May 2016, pp. 1401–1406.
- [155] A. B. Khan, V.-L. Pham, T.-T. Nguyen, and W. Choi, "Multistage constant-current charging method for Li-ion batteries," in *Proc. IEEE Transp. Electrification Conf. Expo. Asia-Pacific (ITEC Asia-Pacific)*, Busan, South Korea, Jun. 2016, pp. 381–385.
- [156] A. K. M. Ahasan Habib, S. M. A. Motakabber, M. I. Ibrahimy, and M. K. Hasan, "Active voltage balancing circuit using single switched-capacitor and series LC resonant energy carrier," *Electron. Lett.*, vol. 56, no. 20, pp. 1036–1039, Sep. 2020.
- [157] A. Samanta and S. Chowdhuri, "Active cell balancing of lithium-ion battery pack using dual DC–DC converter and auxiliary lead-acid battery," *J. Energy Storage*, vol. 33, Jan. 2021, Art. no. 102109.
- [158] C. Riczu and J. Bauman, "Implementation and system-level modeling of a hardware efficient cell balancing circuit for electric vehicle range extension," *IEEE Trans. Ind. Appl.*, vol. 57, no. 3, pp. 2883–2895, May 2021.
- [159] K.-K. Wu, H.-Y. Wang, C. Chen, T. Tao, H. Zhang, K. Wu, and Y.-X. Liu, "Battery voltage transfer method for multi-cells Li-ion battery pack protection chips," *Anal. Integr. Circuits Signal Process.*, vol. 111, no. 1, pp. 13–24, Apr. 2022.
- [160] M. K. Hasan, A. A. Habib, S. Islam, A. T. A. Ghani, and E. Hossain, "Resonant energy carrier base active charge-balancing algorithm," *Electronics*, vol. 9, no. 12, p. 2166, Dec. 2020.
- [161] D. Thiruvonasundari and K. Deepa, "Optimized passive cell balancing for fast charging in electric vehicle," *IETE J. Res.*, vol. 69, no. 4, pp. 1–9, 2021.
- [162] T. Duraisamy and D. Kaliyaperumal, "Adaptive passive balancing in battery management system for e-mobility," *Int. J. Energy Res.*, vol. 45, no. 7, pp. 10752–10764, Jun. 2021.
- [163] F. S. J. Hoekstra, H. J. Bergveld, and M. C. F. Donkers, "Optimal control of active cell balancing: Extending the range and useful lifetime of a battery pack," *IEEE Trans. Control Syst. Technol.*, vol. 30, no. 6, pp. 2759–2766, Nov. 2022.
- [164] F. Qu, Q. Luo, H. Liang, D. Mou, P. Sun, and X. Du, "Systematic overview of active battery equalization structures: Mathematical modeling and performance evaluation," *IEEE Trans. Energy Convers.*, vol. 37, no. 3, pp. 1685–1703, Jan. 2022.
- [165] T. Hein, A. Ziegler, D. Oeser, and A. Ackva, "A capacity-based equalization method for aged lithium-ion batteries in electric vehicles," *Electr. Power Syst. Res.*, vol. 191, Feb. 2021, Art. no. 106898.
- [166] Y.-H. Park, R.-Y. Kim, and Y.-J. Choi, "An active cascaded battery voltage balancing circuit based on multi-winding transformer with small magnetizing inductance," *Energies*, vol. 14, no. 5, p. 1302, Feb. 2021.
- [167] G. Noh, J. Lee, and J.-I. Ha, "Design and analysis of single-inductor power converter for both battery balancing and voltage regulation," *IEEE Trans. Ind. Electron.*, vol. 69, no. 3, pp. 2874–2884, Mar. 2022.
- [168] F. Eroğlu, M. Kurtoglu, and A. M. Vural, "Bidirectional DC–DC converter based multilevel battery storage systems for electric vehicle and large-scale grid applications: A critical review considering different topologies, state-of-charge balancing and future trends," *IET Renew. Power Gener.*, vol. 15, no. 5, pp. 915–938, Apr. 2021.
- [169] A. Turksoy, A. Teke, and A. Alkaya, "A comprehensive overview of the DC–DC converter-based battery charge balancing methods in electric vehicles," *Renew. Sustain. Energy Rev.*, vol. 133, Nov. 2020, Art. no. 110274.
- [170] A. K. M. A. Habib, M. K. Hasan, S. Islam, R. Sharma, R. Hassan, N. Nafi, K. Yadav, and S. Dlaim Alotaibi, "Energy-efficient system and charge balancing topology for electric vehicle application," *Sustain. Energy Technol. Assessments*, vol. 53, Oct. 2022, Art. no. 102516.
- [171] C. Liu, D. Xu, J. Weng, S. Zhou, W. Li, Y. Wan, S. Jiang, D. Zhou, J. Wang, and Q. Huang, "Phase change materials application in battery thermal management system: A review," *Materials*, vol. 13, no. 20, p. 4622, Oct. 2020.
- [172] M. R. Khan, S. J. Andreasen, and S. K. Kaer, "Novel battery thermal management system for greater lifetime ratifying current quality and safety standard," Aalborg Univ., Denmark, Tech. Rep., 2014.
- [173] B. Xia, Y. Liu, R. Huang, Y. Yang, Y. Lai, W. Zheng, H. Wang, W. Wang, and M. Wang, "Thermal analysis and improvements of the power battery pack with liquid cooling for electric vehicles," *Energies*, vol. 12, no. 16, p. 3045, Aug. 2019.
- [174] C. Mi, B. Li, D. Buck, and N. Ota, "Advanced electro-thermal modeling of lithium-ion battery system for hybrid electric vehicle applications," in *Proc. IEEE Vehicle Power Propuls. Conf. (VPPC)*, Sep. 2007, pp. 107–111.
- [175] T. R. Jow, S. A. Delp, J. L. Allen, J.-P. Jones, and M. C. Smart, "Factors limiting Li<sup>+</sup> charge transfer kinetics in Li-ion batteries," *J. Electrochem. Soc.*, vol. 165, no. 2, pp. A361–A367, 2018.
- [176] G.-H. Kim, K. Smith, K.-J. Lee, S. Santhanagopalan, and A. Pesaran, "Multi-domain modeling of lithium-ion batteries encompassing multi-physics in varied length scales," *J. Electrochem. Soc.*, vol. 158, no. 8, p. A955, 2011.
- [177] H. Liu, Z. Wei, W. He, and J. Zhao, "Thermal issues about Li-ion batteries and recent progress in battery thermal management systems: A review," *Energy Convers. Manage.*, vol. 150, pp. 304–330, Oct. 2017.
- [178] J. R. Patel and M. K. Rathod, "Recent developments in the passive and hybrid thermal management techniques of lithium-ion batteries," *J. Power Sources*, vol. 480, Dec. 2020, Art. no. 228820.
- [179] A. K. Thakur, R. Prabakaran, M. R. Elkadeem, S. W. Sharshir, M. Arıcı, C. Wang, W. Zhao, J.-Y. Hwang, and R. Saidur, "A state of art review and future viewpoint on advance cooling techniques for lithium-ion battery system of electric vehicles," *J. Energy Storage*, vol. 32, Dec. 2020, Art. no. 101771.
- [180] Y. Liu, Y. Zhu, and Y. Cui, "Challenges and opportunities towards fast-charging battery materials," *Nature Energy*, vol. 4, no. 7, pp. 540–550, Jun. 2019.
- [181] X. Feng, D. Ren, X. He, and M. Ouyang, "Mitigating thermal runaway of Li-ion batteries," *Joule*, vol. 4, no. 4, pp. 743–770, 2020.
- [182] X. Feng, S. Zheng, X. He, L. Wang, Y. Wang, D. Ren, and M. Ouyang, "Time sequence map for interpreting the thermal runaway mechanism of lithium-ion batteries with LiNi<sub>0.8</sub>Co<sub>0.1</sub>Mn<sub>0.1</sub>O<sub>2</sub> cathode," *Frontiers Energy Res.*, vol. 6, p. 126, Nov. 2018.
- [183] G.-H. Kim, A. Pesaran, and R. Spotnitz, "A three-dimensional thermal abuse model for lithium-ion cells," *J. Power Sources*, vol. 170, no. 2, pp. 476–489, Jul. 2007.
- [184] S. Yayathi, W. Walker, D. Doughty, and H. Ardebili, "Energy distributions exhibited during thermal runaway of commercial lithium ion batteries used for human spaceflight applications," *J. Power Sources*, vol. 329, pp. 197–206, Oct. 2016.
- [185] J. Sun, J. Li, T. Zhou, K. Yang, S. Wei, N. Tang, N. Dang, H. Li, X. Qiu, and L. Chen, "Toxicity, a serious concern of thermal runaway from commercial Li-ion battery," *Nano Energy*, vol. 27, pp. 313–319, Sep. 2016.

- [186] H. Wang, E. Lara-Curzio, E. T. Rule, and C. S. Winchester, "Mechanical abuse simulation and thermal runaway risks of large-format Li-ion batteries," *J. Power Sources*, vol. 342, pp. 913–920, Feb. 2017.
- [187] A. Friesen, F. Horsthemke, X. Mönninghoff, G. Brunklaus, R. Krafft, M. Böchner, T. Risthaus, M. Winter, and F. M. Schappacher, "Impact of cycling at low temperatures on the safety behavior of 18650-type lithium ion cells: Combined study of mechanical and thermal abuse testing accompanied by post-mortem analysis," *J. Power Sources*, vol. 334, pp. 1–11, Dec. 2016.
- [188] B. K. Mandal, A. K. Padhi, Z. Shi, S. Chakraborty, and R. Filler, "Thermal runaway inhibitors for lithium battery electrolytes," *J. Power Sources*, vol. 161, no. 2, pp. 1341–1345, Oct. 2006.
- [189] R. M. Spotnitz, J. Weaver, G. Yeduvaka, D. H. Doughty, and E. P. Roth, "Simulation of abuse tolerance of lithium-ion battery packs," *J. Power Sources*, vol. 163, no. 2, pp. 1080–1086, Jan. 2007.
- [190] J. Ludwig and T. Nilges, "Recent progress and developments in lithium cobalt phosphate chemistry- syntheses, polymorphism and properties," *J. Power Sources*, vol. 382, pp. 101–115, Apr. 2018.
- [191] M. Fischer, M. Werber, and P. V. Schwartz, "Batteries: Higher energy density than gasoline?" *Energy Policy*, vol. 37, no. 7, pp. 2639–2641, Jul. 2009.
- [192] P. Sun, R. Bisschop, H. Niu, and X. Huang, "A review of battery fires in electric vehicles," *Fire Technol.*, vol. 56, pp. 1–50, Jan. 2020.
- [193] L. Bravo Diaz, X. He, Z. Hu, F. Restuccia, M. Marinescu, J. V. Barreras, Y. Patel, G. Offer, and G. Rein, "Review—Meta-review of fire safety of lithium-ion batteries: Industry challenges and research contributions," *J. Electrochem. Soc.*, vol. 167, no. 9, Jan. 2020, Art. no. 090559.
- [194] R. Kantharaj and A. M. Marconnet, "Heat generation and thermal transport in lithium-ion batteries: A scale-bridging perspective," *Nanoscale Microscale Thermophysical Eng.*, vol. 23, no. 2, pp. 128–156, Apr. 2019.
- [195] A. R. Dehghani-Sanj, E. Tharumalingam, M. B. Dusseault, and R. Fraser, "Study of energy storage systems and environmental challenges of batteries," *Renew. Sustain. Energy Rev.*, vol. 104, pp. 192–208, Apr. 2019.
- [196] A. Beylot and J. Villeneuve, "Accounting for the environmental impacts of sulfidic tailings storage in the life cycle assessment of copper production: A case study," *J. Cleaner Prod.*, vol. 153, pp. 139–145, Jun. 2017.
- [197] F. Cerdas, S. Andrew, S. Thiede, and C. Herrmann, "Environmental aspects of the recycling of lithium-ion traction batteries," 2018, pp. 267–288, doi: [10.1007/978-3-319-70572-9\\_16](https://doi.org/10.1007/978-3-319-70572-9_16).
- [198] M. C. Mcmanus, "Environmental consequences of the use of batteries in low carbon systems: The impact of battery production," *Appl. Energy*, vol. 93, pp. 288–295, May 2012.
- [199] EU. Directive 2006/66/EC of the European Parliament and of the Council of 6 September 2006 on Batteries and Accumulators and Waste Batteries and Accumulators and Repealing Directive 91/157/EEC. [Online]. Available: [http://www.legislation.gov.uk/eu/dr/2006/66/pdfs/eu\\_dr\\_20060066\\_adopted\\_en.pdf](http://www.legislation.gov.uk/eu/dr/2006/66/pdfs/eu_dr_20060066_adopted_en.pdf)
- [200] D. N. Perkins, M.-N. B. Drisse, T. Nxele, and P. D. Sly, "E-waste: A global hazard," *Ann. Global Health*, vol. 80, no. 4, p. 286, Nov. 2014.
- [201] P. Stepnowski, W. Mroziak, and J. Nidhauser, "Adsorption of alkylimidazolium and alkylpyridinium ionic liquids onto natural soils," *Environ. Sci. Technol.*, vol. 41, no. 2, pp. 511–516, Jan. 2007.
- [202] H. Omar and S. Rohani, "Treatment of landfill waste, leachate and landfill gas: A review," *Frontiers Chem. Sci. Eng.*, vol. 9, no. 1, pp. 15–32, Mar. 2015.
- [203] S. Barcellona, S. Colnago, G. Dotelli, S. Latorrata, and L. Piegari, "Aging effect on the variation of Li-ion battery resistance as function of temperature and state of charge," *J. Energy Storage*, vol. 50, Jun. 2022, Art. no. 104658.
- [204] P. A. Christensen, P. A. Anderson, G. D. J. Harper, S. M. Lambert, W. Mroziak, M. A. Rajaeifar, M. S. Wise, and O. Heidrich, "Risk management over the life cycle of lithium-ion batteries in electric vehicles," *Renew. Sustain. Energy Rev.*, vol. 148, Sep. 2021, Art. no. 111240.
- [205] Y. Chen, Y. Kang, Y. Zhao, L. Wang, J. Liu, Y. Li, Z. Liang, X. He, X. Li, N. Tavajohi, and B. Li, "A review of lithium-ion battery safety concerns: The issues, strategies, and testing standards," *J. Energy Chem.*, vol. 59, pp. 83–99, Aug. 2021.
- [206] A. K. M. A. Habib, M. K. Hasan, S. Islam, M. M. Ahmed, A. H. M. Aman, A. Bagwari, and S. Khan, "Voltage equalization circuit for retired batteries for energy storage applications," *Energy Rep.*, vol. 8, pp. 367–374, Nov. 2022.
- [207] M. A. Hannan, Md. M. Hoque, S. E. Peng, and M. N. Uddin, "Lithium-ion battery charge equalization algorithm for electric vehicle applications," *IEEE Trans. Ind. Appl.*, vol. 53, no. 3, pp. 2541–2549, May 2017.
- [208] S. Moore and P. Schneider, "A review of cell equalization methods for lithium ion and lithium polymer battery systems," SAE Tech. Papers 2001-01-0959, 2001.
- [209] L. Yun, D. Linh, L. Shui, X. Peng, A. Garg, M. L. P. Le, S. Asghari, and J. Sandoval, "Metallurgical and mechanical methods for recycling of lithium-ion battery pack for electric vehicles," *Resour. Conservation Recycling*, vol. 136, pp. 198–208, Sep. 2018.
- [210] N. Xue, "Design and optimization of Li-ion batteries for electric-vehicle applications," Ph.D. dissertation, Dept. Aerosp. Eng., Univ. Michigan, Ann Arbor, MI, USA, 2014.
- [211] S. Arora, W. Shen, and A. Kapoor, "Review of mechanical design and strategic placement technique of a robust battery pack for electric vehicles," *Renew. Sustain. Energy Rev.*, vol. 60, pp. 1319–1331, Jul. 2016.
- [212] A. Hamidi, L. Weber, and A. Nasiri, "EV charging station integrating renewable energy and second-life battery," in *Proc. Int. Conf. Renew. Energy Res. Appl. (ICRERA)*, Oct. 2013, pp. 1217–1221.
- [213] M. S. H. Lipu, M. A. Hannan, A. Hussain, M. M. Hoque, P. J. Ker, M. H. M. Saad, and A. Ayob, "A review of state of health and remaining useful life estimation methods for lithium-ion battery in electric vehicles: Challenges and recommendations," *J. Cleaner Prod.*, vol. 205, pp. 115–133, Dec. 2018.
- [214] C. Peng, C. Wu, L. Gao, J. Zhang, K.-L. A. Yau, and Y. Ji, "Blockchain for vehicular Internet of Things: Recent advances and open issues," *Sensors*, vol. 20, no. 18, p. 5079, Sep. 2020.
- [215] Abizar, H. Farman, B. Jan, Z. Khan, and A. Koubaa, "A smart energy-based source location privacy preservation model for Internet of Things-based vehicular ad hoc networks," *Trans. Emerg. Telecommun. Technol.*, vol. 33, no. 2, pp. 1–14, Feb. 2022.
- [216] Z. Du, C. Wu, T. Yoshinaga, K.-L.-A. Yau, Y. Ji, and J. Li, "Federated learning for vehicular Internet of Things: Recent advances and open issues," *IEEE Open J. Comput. Soc.*, vol. 1, pp. 45–61, 2020.
- [217] C. S. C. Bose and F. C. Laman, "Battery state of health estimation through coup de fouet," in *Proc. Int. Telecommun. Energy Conf. (INTELEC)*, 2000, pp. 597–601.
- [218] C. Shinagawa, H. Ushiyama, and K. Yamashita, "Multiscale simulations for lithium-ion batteries: SEI film growth and capacity fading," *J. Electrochem. Soc.*, vol. 164, no. 13, pp. A3018–A3024, 2017.
- [219] J. Kim, H. Ma, H. Cha, H. Lee, J. Sung, M. Seo, P. Oh, M. Park, and J. Cho, "A highly stabilized nickel-rich cathode material by nanoscale epitaxy control for high-energy lithium-ion batteries," *Energy Environ. Sci.*, vol. 11, no. 6, pp. 1449–1459, 2018.
- [220] Y. Sun, Y. Zhao, J. Wang, J. Liang, C. Wang, Q. Sun, X. Lin, K. R. Adair, J. Luo, D. Wang, R. Li, M. Cai, T. Sham, and X. Sun, "A novel organic 'polyurea' thin film for ultralong-life lithium-metal anodes via molecular-layer deposition," *Adv. Mater.*, vol. 31, no. 4, Jan. 2019, Art. no. 1806541.
- [221] C. Lin, A. Tang, and W. Wang, "A review of SOH estimation methods in lithium-ion batteries for electric vehicle applications," *Energy Proc.*, vol. 75, pp. 1920–1925, Aug. 2015.
- [222] Y. Zou, X. Hu, H. Ma, and S. E. Li, "Combined state of charge and state of health estimation over lithium-ion battery cell cycle lifespan for electric vehicles," *J. Power Sources*, vol. 273, pp. 793–803, Jan. 2015.
- [223] X. Yuan, H. Liu, and J. Zhang, Eds., *Lithium-Ion Batteries: Advanced Materials and Technologies*, 1st ed. Boca Raton, FL, USA: CRC Press, 2011, doi: [10.1201/b11292](https://doi.org/10.1201/b11292).
- [224] J. Sabatier, M. Aoun, A. Oustaloup, G. Grégoire, F. Ragot, and P. Roy, *Signal Process.*, vol. 86, pp. 2645–2657, 2006.
- [225] A. Bandyopadhyay, L. Wang, V. K. Devabhaktuni, R. Yang, and R. C. Green, "Assessing the effect of fast charging on the battery health of plug-in hybrid electric vehicles," in *Proc. IEEE Power Energy Soc. Gen. Meeting*, 2012, pp. 1–8, doi: [10.1109/PESGM.2012.6345617](https://doi.org/10.1109/PESGM.2012.6345617).
- [226] L. Lu, X. Han, J. Li, J. Hua, and M. Ouyang, "A review on the key issues for lithium-ion battery management in electric vehicles," *J. Power Sources*, vol. 226, pp. 272–288, 2013, doi: [10.1016/j.jpowsour.2012.10.060](https://doi.org/10.1016/j.jpowsour.2012.10.060).
- [227] E. Meissner and G. Richter, "Battery monitoring and electrical energy management: Precondition for future vehicle electric power systems," *J. Power Sources*, vol. 116, pp. 79–98, Jul. 2003.
- [228] K. Wang, F. Gao, Y. Zhu, H. Liu, C. Qi, K. Yang, and Q. Jiao, "Internal resistance and heat generation of soft package Li<sub>4</sub>Ti<sub>5</sub>O<sub>12</sub> battery during charge and discharge," *Energy*, vol. 149, pp. 364–374, Apr. 2018.
- [229] X. Wei, B. Zhu, and W. Xu, "Internal resistance identification in vehicle power lithium-ion battery and application in lifetime evaluation," in *Proc. Int. Conf. Measuring Technol. Mechatronics Autom.*, Zhangjiajie, China, vol. 3, Apr. 2009, pp. 388–392.

- [230] H. Chaoui and H. Gualous, "Online parameter and state estimation of lithium-ion batteries under temperature effects," *Electr. Power Syst. Res.*, vol. 145, pp. 73–82, Apr. 2017.
- [231] M. Galeotti, L. Cinà, C. Giammanco, S. Cordiner, and A. Di Carlo, "Performance analysis and SOH (state of health) evaluation of lithium polymer batteries through electrochemical impedance spectroscopy," *Energy*, vol. 89, pp. 678–686, Sep. 2015.
- [232] Y. Cui, P. Zuo, C. Du, Y. Gao, J. Yang, X. Cheng, Y. Ma, and G. Yin, "State of health diagnosis model for lithium ion batteries based on real-time impedance and open circuit voltage parameters identification method," *Energy*, vol. 144, pp. 647–656, Feb. 2018.
- [233] V. Ovejas and A. Cuadras, "Impedance characterization of an LCO-NMC/graphite cell: Ohmic conduction, SEI transport and charge-transfer phenomenon," *Batteries*, vol. 4, no. 3, p. 43, Sep. 2018.
- [234] X. Li, Z. Wang, L. Zhang, C. Zou, and D. D. Dorrell, "State-of-health estimation for Li-ion batteries by combing the incremental capacity analysis method with grey relational analysis," *J. Power Sources*, vols. 410–411, pp. 106–114, Jan. 2019.
- [235] R. Xiong, Y. Zhang, J. Wang, H. He, S. Peng, and M. Pecht, "Lithium-ion battery health prognosis based on a real battery management system used in electric vehicles," *IEEE Trans. Veh. Technol.*, vol. 68, no. 5, pp. 4110–4121, May 2019.
- [236] S. Onori and M. Via, "A new life estimation method for Li-ion batteries in plug-in hybrid electric vehicles applications," *Pierfrancesco Spagnol Vincenzo Marano Yann Guezennec and Giorgio Rizzoni*, ; vol. 4, no. 3, pp. 302–319, 2012.
- [237] K. S. Ng, C.-S. Moo, Y.-P. Chen, and Y.-C. Hsieh, "Enhanced Coulomb counting method for estimating state-of-charge and state-of-health of lithium-ion batteries," *Appl. Energy*, vol. 86, no. 9, pp. 1506–1511, Sep. 2009.
- [238] X. Zhang, R. Grube, K.-K. Shin, M. Salman, and R. Conell, "Automotive battery state-of-health monitoring: A parity relation based approach," *IFAC Proc. Volumes*, vol. 42, no. 8, pp. 552–557, 2009.
- [239] X. Feng, J. Li, M. Ouyang, L. Lu, J. Li, and X. He, "Using probability density function to evaluate the state of health of lithium-ion batteries," *J. Power Source*, vol. 232, pp. 209–218, Jun. 2013.
- [240] N. Chen, X. Hu, W. Gui, and J. Zou, "Estimation of Li-ion battery state of charging and state of healthy based on unsented Kalman filtering," in *Proc. 26th Chin. Control Decis. Conf. (CCDC)*, Changsha, China, May/Jun. 2014, pp. 4725–4729.
- [241] I.-S. Kim, "A technique for estimating the state of health of lithium batteries through a dual-sliding-mode observer," *IEEE Trans. Power Electron.*, vol. 25, no. 4, pp. 1013–1022, Apr. 2010.
- [242] L. Rozaqi, E. Rijanto, and S. Kanarachos, "Comparison between RLS-GA and RLS-PSO for Li-ion battery SOC and SOH estimation: A simulation study," *J. Mechatronics, Electr. Power, Veh. Technol.*, vol. 8, no. 1, pp. 40–49, Jul. 2017.
- [243] E. Rijanto, L. Rozaqi, A. Nugroho, and S. Kanarachos, "RLS with optimum multiple adaptive forgetting factors for SoC and SoH estimation of Li-ion battery," in *Proc. 5th Int. Conf. Instrum., Control, Autom. (ICA)*, Yogyakarta, Indonesia, Aug. 2017, pp. 73–77.
- [244] H. He, X. Zhang, R. Xiong, Y. Xu, and H. Guo, "Online model-based estimation of state-of-charge and open-circuit voltage of lithium-ion batteries in electric vehicles," *Energy*, vol. 39, no. 1, pp. 310–318, Mar. 2012.
- [245] M. Yue, S. Jemei, R. Gouriveau, and N. Zerhouni, "Developing a health-conscious energy management strategy based on prognostics for a battery/fuel cell hybrid electric vehicle," in *Proc. IEEE Vehicle Power Propuls. Conf. (VPPC)*, Chicago, IL, USA, Aug. 2018, pp. 1–6.
- [246] H. Pan, Z. Lü, H. Wang, H. Wei, and L. Chen, "Novel battery state-of-health online estimation method using multiple health indicators and an extreme learning machine," *Energy*, vol. 160, pp. 466–477, Oct. 2018.
- [247] J. Zhang, H. Zhong, J. Cui, Y. Xu, and L. Liu, "An extensible and effective anonymous batch authentication scheme for smart vehicular networks," *IEEE Internet Things J.*, vol. 7, no. 4, pp. 3462–3473, Apr. 2020.
- [248] S. Sachan, S. Deb, and S. N. Singh, "Different charging infrastructures along with smart charging strategies for electric vehicles," *Sustain. Cities Soc.*, vol. 60, Sep. 2020, Art. no. 102238, doi: [10.1016/j.scs.2020.102238](https://doi.org/10.1016/j.scs.2020.102238).
- [249] M. Aganti and B. Chokkalingam, "A photovoltaic powered wireless charging system for light-duty electric vehicles with reflective panel analysis," *Energy Sources, A, Recovery, Utilization, Environ. Effects*, vol. 45, no. 2, pp. 3811–3830, 2023, doi: [10.1080/15567036.2023.2196263](https://doi.org/10.1080/15567036.2023.2196263).
- [250] M. Aganti, B. Kowsik, R. Latha, and C. Bharatiraja, "Half bridge based multi leg converter for dynamic EV charging system," in *Proc. IEEE IAS Global Conf. Renew. Energy Hydrogen Technol. (GlobConHT)*, Male, Maldives, Mar. 2023, pp. 1–4, doi: [10.1109/GlobConHT56829.2023.10087404](https://doi.org/10.1109/GlobConHT56829.2023.10087404).
- [251] P. K. Chittoor and C. Bharatiraja, "Building integrated photovoltaic powered wireless drone charging system," *Solar Energy*, vol. 252, pp. 163–175, Mar. 2023, doi: [10.1016/j.solener.2023.01.056](https://doi.org/10.1016/j.solener.2023.01.056).
- [252] A. Mahesh, B. Chokkalingam, and L. Mihet-Popa, "Inductive wireless power transfer charging for electric vehicles—A review," *IEEE Access*, vol. 9, pp. 137667–137713, 2021, doi: [10.1109/ACCESS.2021.3116678](https://doi.org/10.1109/ACCESS.2021.3116678).
- [253] R. Gopalasami, B. Chokkalingam, and S. Muthusamy, "A novel method for hybridization of super lift Luo converter and boost converter for electric vehicle charging applications," *Energy Sources, A, Recovery, Utilization, Environ. Effects*, vol. 45, no. 3, pp. 8419–8437, 2023, doi: [10.1080/15567036.2023.2226104](https://doi.org/10.1080/15567036.2023.2226104).
- [254] D. A. Savio, V. A. Juliet, B. Chokkalingam, S. Padmanaban, J. B. Holm-Nielsen, and F. Blaabjerg, "Photovoltaic integrated hybrid microgrid structured electric vehicle charging station and its energy management approach," *Energies*, vol. 12, no. 1, p. 168, Jan. 2019, doi: [10.3390/en12010168](https://doi.org/10.3390/en12010168).
- [255] B. Chokkalingam, S. Padmanaban, P. Siano, R. Krishnamoorthy, and R. Selvaraj, "Real-time forecasting of EV charging station scheduling for smart energy systems," *Energies*, vol. 10, no. 3, p. 377, Mar. 2017, doi: [10.3390/en10030377](https://doi.org/10.3390/en10030377).
- [256] S. Harini, N. Chellammal, B. Chokkalingam, and L. Mihet-Popa, "A novel high gain dual input single output Z-quasi resonant (ZQR) DC/DC converter for off-board EV charging," *IEEE Access*, vol. 10, pp. 83350–83367, 2022, doi: [10.1109/ACCESS.2022.3195936](https://doi.org/10.1109/ACCESS.2022.3195936).
- [257] S. Alwar, D. Samithas, M. S. Boominathan, P. K. Balachandran, and L. Mihet-Popa, "Performance analysis of thermal image processing-based photovoltaic fault detection and PV array reconfiguration—A detailed experimentation," *Energies*, vol. 15, no. 22, p. 8450, Nov. 2022, doi: [10.3390/en15228450](https://doi.org/10.3390/en15228450).
- [258] A. Saxena, R. Kumar, A. K. Rawat, M. Majid, J. Singh, S. Devakirubakaran, and G. K. Singh, "Abnormal health monitoring and assessment of a three-phase induction motor using a supervised CNN-RNN-based machine learning algorithm," *Math. Problems Eng.*, vol. 2023, pp. 1–8, Jan. 2023, doi: [10.1155/2023/1264345](https://doi.org/10.1155/2023/1264345).
- [259] S. Devakirubakaran, R. Verma, C. Bharatiraja, and L. Mihet-Popa, "Performance evaluation of static PV array configurations for mitigating mismatch losses," *IEEE Access*, vol. 11, pp. 47725–47749, 2023, doi: [10.1109/ACCESS.2023.3274684](https://doi.org/10.1109/ACCESS.2023.3274684).



**R. RANJITH KUMAR** received the B.E. degree in electronics and instrumentation engineering from Anna University, in 2021, where he is currently pursuing the master's degree in control and instrumentation engineering. He is also doing his internship with the Center for Electric Mobility, Department of Science and Technology, Government of India, Promotion of University Research and Scientific Excellence (PURSE) Project, SRM Institute of Science and Technology, Chennai. His main research interests include battery management systems, machine learning, control systems, and instrumentations.



**C. BHARATIRAJA** (Senior Member, IEEE) received the B.E. degree in electrical and electronics engineering from the Kumaraguru College of Engineering, Coimbatore, India, in 2002, the M.E. degree in power electronics and drives from the Government College of Technology, Coimbatore, in 2006, and the Ph.D. degree from the SRM Institute of Science and Technology, in 2015. He completed his first Postdoctoral Fellowship with the Centre for Energy and Electric Power, Faculty of Engineering and the Built Environment, Tshwane University of Technology, South Africa, in 2016, with the National Research Foundation Funding, and his second Postdoctoral Fellowship with the Department of Electrical and Computer Engineering, Northeastern University, USA. He was a Visiting Research Scientist with Northeastern University, Boston, MA, USA, in 2018, and a Visiting Researcher with the University of South Africa, in 2019 and 2020. He is currently a Professor with the Department of Electrical and Electronics Engineering, SRM Institute of Science and Technology, Kattankulathur Campus, Chennai, India. He is also the Centre Head of the Centre for the E-Mobility, SRM Institute of Science and Technology.



He is handling/handled government-funded projects totaling Rs. 15.65 Cr, including SERB, DST, and TNSCST. He has authored more than 180 research articles ten books chapters, and ten IPR patents in his name. He also made three technology transfers. He is a Senior Member of IET and IET. He is also a member, a mentor, and an advisor of many government and private companies bodies. He was a recipient of the DST, Indo-U.S. Bhaskara Advanced Solar Energy, in 2017, and the Young Scientists Fellowship, Tamil Nadu State Council for Science and Technology, in 2018. He was also a recipient of the World's Top 2% Scientists 2021 and 2022 in the energy category. For more information: <https://www.srmist.edu.in/faculty/dr-c-bharatiraja/>.



**K. UDHAYAKUMAR** received the B.E. degree in electrical and electronics engineering from the University of Madras, in 1998, the M.E. degree in power systems engineering from Annamalai University, in 1999, and the Ph.D. degree from the Faculty of Electrical Engineering, Anna University, Chennai, in 2009. He is currently a Professor with the Department of Electrical and Electronics Engineering, Anna University, with 23 years of teaching and research experience in academia.

He is currently affiliated with Anna University, where he contributes to the academic and research activities in his field. His doctoral research focused on the design of advanced robust controllers for variable structure systems. His expertise lies in the field of electrical engineering, particularly in sensors and instrumentation, machine learning, and EV technology. He has made significant contributions to teaching, research, and various professional activities. His research accomplishments are evident through his numerous papers published in reputable journals, book chapters, and conference proceedings. Recognized for his expertise, he has been invited to deliver lectures on various topics related to his research. His presentations have provided valuable insights to students, fellow researchers, and professionals, fostering knowledge exchange and promoting academic growth. Throughout his career, he has actively engaged in professional bodies, demonstrating his commitment to staying updated with the latest advancements in his field. Beyond his academic pursuits, he actively participated in extension and outreach activities. He is committed to applying his knowledge and skills to benefit society at large. Through these initiatives, he has made a positive impact, addressing real-world challenges and contributing to the betterment of the community.



**S. DEVAKIRUBAKARAN** received the B.E. degree in electrical and electronics engineering and the M.E. degree in power systems engineering from Anna University, Chennai, India, in 2014 and 2016, respectively, and the Ph.D. degree from the Department of Science and Technology (DST), Solar Energy Research Initiative (SERI) Scheme Project, in 2022. He is currently a Project Associate with the Center for Electric Mobility, Department of Science and Technology, Govern-

ment of India, Promotion of University Research and Scientific Excellence (PURSE) Project, SRM Institute of Science and Technology, Chennai. His main research interests include power systems, renewable energy systems, machine learning, and solar photovoltaic systems.



**K. SATHIYA SEKAR** was born in Erode, Tamil Nadu, India. He received the B.E. degree in electrical and electronics engineering from Madras University, in 1999, the M.Tech. degree in high voltage engineering from SASTRA University, Tanjore, in 2002, and the Ph.D. degree in high voltage engineering from Anna University, Chennai, India, in 2010. He is currently a professor with the Department of Electrical and Electronics Engineering, K S R Institute for Engineering and

Technology, Tiruchengode. Thirteen scholars have completed their Ph.D. degree under his guidance and eight others are currently pursuing the Ph.D. degree with Anna University. He has been an Expert Member of the Ph.D. Viva-Voce Examination (University Nominee). He received a fund of Rs. 2.5 crores from the Ministry of MSME for Business Incubation Cell and also received funds from MNRE, Government of India for the FDP Program. He is an Editorial Board Member of *International Journal of Advanced Research in Electrical, Electronics and Instrumentation Engineering*. He received the Award of Certificate of Outstanding Contribution in Reviewing from *International Journal of Electrical Power and Energy Systems* (Elsevier, Amsterdam, The Netherlands). He received the Best Paper Award from the International Conference on Digital Factory-2008, held at CIT, Coimbatore. He is a reviewer of reputed journals, such as IEEE, Elsevier, Technical Gazette, and Australian journals.



**LUCIAN MIHET-POPA** (Senior Member, IEEE) was born in 1969. He received the bachelor's degree in electrical engineering, the master's degree in electric drives and power electronics, and the Ph.D. and Habilitation degrees in electrical engineering from the Politehnica University of Timisoara, Romania, in 1999, 2000, 2002, and 2015, respectively. From 1999 to 2016, he was with the Politehnica University of Timisoara.

He was a Research Scientist with Danish Technical University, from 2011 to 2014, and also with Aalborg University, Denmark, from 2000 to 2002. He held a postdoctoral position with Siegen University, Germany, in 2004. Since 2016, he has been a Full Professor of energy technology with Østfold University College, Norway. He is currently the Head of the Research Laboratory "Intelligent Control of Energy Conversion and Storage Systems" and is one of the coordinators of the master's degree program in "Green Energy Technology" with the Faculty of Engineering, Østfold University College. He has participated in more than 15 international grants/projects, such as FP7, EEA, and Horizon 2020. He has been awarded more than ten national research grants. He has published more than 130 papers in national and international journals, conference proceedings, and ten books. His research interests include modeling, simulation, control, and testing of energy conversion systems, and distributed energy resources (DER) components and systems, including battery storage systems (BSS) (for electric vehicles and hybrid cars and vanadium redox batteries (VRB) and energy efficiency in smart buildings and smart grids. He has served as a scientific and technical program committee member for many IEEE conferences. He was invited to join the Energy and Automotive Committees by the President and the Honorary President of the Atomium European Institute, working in close cooperation with—under the umbrella—the EC and EU Parliament, and was also appointed as the Chairman of AI4People, Energy Section. Since 2017, he has been the Guest Editor of five special issues of *Energies* (MDPI), *Applied Sciences*, *Majlesi Journal of Electrical Engineering*, and *Advances in Meteorology*.

...