

Received 24 August 2023, accepted 7 September 2023, date of publication 15 September 2023, date of current version 25 September 2023.

Digital Object Identifier 10.1109/ACCESS.2023.3316016



A Comprehensive Review of the State-of-the-Art of Secondary Control Strategies for Microgrids

FAWAD NAWAZ¹, (Student Member, IEEE), EHSAN PASHAJAVID², (Senior Member, IEEE),
YUANYUAN FAN¹, (Senior Member, IEEE), AND MUNIRA BATOOL¹, (Senior Member, IEEE)

¹Department of Electrical Engineering, Engineering Institute of Technology, Perth, WA 6005, Australia

²School of Electrical Engineering, Computing and Mathematical Sciences, Curtin University, Bentley, WA 6102, Australia

Corresponding author: Munira Batool (munira.batool@eit.edu.au)

This work was supported by the Engineering Institute of Technology, Perth, Western Australia.

ABSTRACT The proliferation of distributed energy resources in distribution systems has given rise to a new concept known as Microgrids (MGs). The effective control of MGs is a crucial aspect that needs to be prioritized before undertaking any implementation procedure. This article provides a comprehensive overview of hierarchical control methods that ensure efficient and robust control for MGs. Specifically, it focuses on the secondary controller approaches (centralized, distributed, and decentralized control) and examines their primary strengths and weaknesses. The techniques are thoroughly discussed, deliberated, and compared to facilitate a better understanding. According to functionality, the hierarchical-based control scheme is allocated into three levels: primary, secondary, and tertiary. For secondary control level, the MG communication structures permit the usage of various control methods that provided the significance of the secondary controller for consistent and reliable MG performance and the deficiency of an inclusive recommendation for scholars. Also, it gives a review of the literature on present important matters related to MG secondary control approaches in relation to the challenges of communication systems. The problem of the secondary level control is deliberated with an emphasis on challenges like delays. Further, at the secondary layer, the distributed control techniques for reducing communication system utilization and then reducing communication system delays are conferred. Furthermore, the benefits and limitations of various control structures, such as centralized, decentralized, and distributed are also discussed in this study. Later a comparative analysis of entire control approaches, the best methods of control according to the author's perspective are also discussed.

INDEX TERMS MG, hierarchical control, distributed generators, secondary level control, centralized control, distributed control, decentralized control.

NOMENCLATURE

DGs	Distributed generators.
ESS	Energy storage systems.
LC	Load controller.
LV	Low Voltages.
MAS	Multi-Agent System.
MC	Micro-source Controller.
DGs	Distributed generators.

ESS	Energy storage systems.
LC	Load controller.
LV	Low Voltages.
MAS	Multi-Agent System.
MC	Micro-source Controller.

I. INTRODUCTION

For the last few years, isolated grids are considered as a feasible way out for power supply based on Energy Storage Systems and DG. The growth and enhancement of the schemes of control have altered the way of understanding and designing these systems. This change directed the

The associate editor coordinating the review of this manuscript and approving it for publication was Tariq Masood¹.

development of a new idea known as MG [1], [2], [3], [4], [5]. Moreover, the concept of the multi-MG has just got further attention because of its characteristics of obliging the large-scale incorporation of renewable energy sources with effective utilization, better efficiency of power system, stability and reliability performance by collaboration and coordination of the exchange of energy between the MGs and the main grid. However, the improvement of MGs presents some challenges that must be assessed individually; Challenges include safety, control, stability, and operation [6], [7].

MGs may work in connected and islanded ways [8], [9], [10], [11]; In these modes of operation, there are a few challenges like voltage and frequency stability, and precise distribution of power [12], [13]; Therefore, an appropriate control assembly is essential for reliable performance of the MG. Moreover, selecting the right communication system to enhance system consistency and security to increase packet loss, time delay and bandwidth is a major task. The data alteration in MGs as well as diverse stages of control needs a communication system; that are systematized via a hierarchical-based control assembly. Figure 1 displays the hierarchical structure of a MG control network created on three layers of control called primary, secondary, and tertiary control.

- **Primary control layer:** Initially the controller is accountable for keeping the stability of frequency and voltage, that influence the MG constancy because of quick procedures of controller. To improve the PQ and accurateness of the initial level power distribution, the loop of virtual impedance is electively utilized [14]. On the primary stage, controllers are employed with local quantities, thus they do not need a difficult communication system [15], [16], [17]. Because of the time mandatory for the exchange of data to distribute the same power in the MG divisions, an independent method is generally implemented for the first control [18], [19], [20], [21].
- **Secondary Control layer-** Along with the primary control, secondary control layers are added to the network that deliver a reference to the primary control to simultaneously provide proportional current distribution and voltage regulation. Secondary control approaches are deliberate in relation to the requirement of communication systems on three configurations: centralized, distributed and decentralized [22].
- **Tertiary control layer:** Tertiary control is a complement to the primary and secondary control layers that offers controller signals to secondary control to solve power management and distribution difficulties in MGs [23].

Communication link based control approaches in MGs may be classified as following [24]:

- **Centralized control technique:** A centralized controller is utilized to manage the distributed production sections and data transmitted over high bandwidth communication links.

- **Distributed control technique:** Every single controller communicates with other units via a mutual bus. It uses a digital based communication link.
- **Decentralized control technique:** The units of DG are controlled and deprived of a communication connection, creating autonomous choices depend on locally accessible parameters.

The Table 1 summarized the advantages and disadvantages of each control.

TABLE 1. Advantages and disadvantages of control techniques.

Control Technique	Advantages	Disadvantages
Centralized	Better in results because of the proper coordination and accessibility of the global information	The requirement of the central controller and the enormous communication links make it inflexible and inclined to the single point failure
Distributed	Less communication stress and the flexible in the nature Resistant to the failure of single point	The delay in communication and the Complex mathematical analysis affects the system stability
Decentralized	Less complex and more reliable	The limitation of the system performance because of the lack of global data

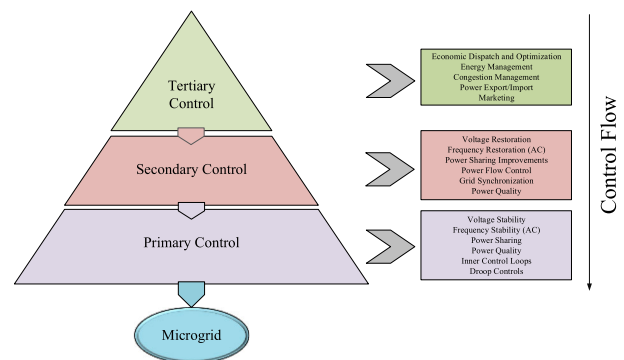

FIGURE 1. MG hierarchical control configuration.

As communication resources in the MG are restricted, it is desirable to reduce the dependence on the communication system. Hence, that's lead to pay greater consideration to decentralized and distributed systems because of less dependency on communication system as compared to centralized system which needs difficult communication system [25], [26], [27]. The reliance of MGs on communication systems are also has drawbacks like communication interruptions. Because of this, new control arrangements have been proposed in this manner that control goals may constantly be certain even in event of communication interruptions [28], [29]. Latest researches have deliberated the development of new secondary level control for frequency and voltage recovery as well as precise power distribution rely

on an event-triggered condition [30], [31], [32]. Because of the expensive communication systems, a lot of research have been directed to diminish the dependence of secondary layer controller on the communication structure [33].

During the analysis of some major demonstrations projects identify that in designing these systems there is no structured information. Genuinely, according to the research analysis, the MGs have been construct with numerous control framework and architectures, compromising MGs that may be operated in on-grid mode simply and in off and on-grid modes both. In the latest case, the frequency and voltage of system are controlled through adopting droop controlled or main/secondary controllers. Amongst the droop controlled MGs, the Kythons Island MG is well recognized, that was created by the goal of developing the decentralized and centralized controlled schemes for the independent networks. In contrast, the consistency and economic management of the islanded MG is the key goal of the Huatacondo MG, while the continuous MV/LV MG is utilized to develop the control schemes capable to control the voltage and the frequency of the islanded network.

The MG of Bornholm may be controlled as an islanded in addition to parallel with grid. However, it is categorized as the islanded MG because it is operated in the mode of off-grid for utmost of time. Similarly, the test facility of CESI RICERCA DER is involved in the droop controlled based MG. It has been made by the objective to examine the stability of frequency and voltage along with the latest protection strategies and the design necessities for the storage devices of independent MGs. It is based on the centralized control network which permits altering the network configuration thus that numerous grid topologies may be studies.

MGs are generally eye-catching for their capability to encourage the integration of distributed energy sources (DER) in to the distribution system. Therefore, the Prince Lab MG at the Polytechnic University of Bari (Italy) was established to give operational and technical commendations for make sure reliability, security, resilience, and interoperability in further realistic cases and depend on the commercially existing DER [13].

The main objective of this paper is to give the inclusive review about the prevailing secondary level control methods as well as to indicate the possibilities for the further research in this field. In that sense, few research article providing MG reviews [34], [35], some focused on MG control [36], [37], [38] and few are on the secondary layer control system [22]. In view of the extensive study on communication system of MGs, this article emphasis on the secondary level control and configurations utilized in secondary layer through looking at lessening dependency on the infrastructure of communication and by considering diverse methods based on distributed control.

The remaining paper is systematized as follows: The section II briefly explains the MGs hierarchical control system. In Section III the secondary layer control methods are categorized then compared with each other, as well as

the significance of this network is highlighted via inspecting methods that depends on the distributed system. The Section IV categorizes the communication system utilized in MG. Lastly, in section V, the conclusion is presented.

II. CONTROL STRUCTURE OF MICROGRID

Figure 2 displays the network of a usual low voltage MG as well as relationship between the MG controllers [39]. In general, MG includes low voltage power supplies, loads, micro sources (such as wind energy conversion system (WECS), micro-turbine, photovoltaic (PV), fuel cell) and storage equipment's (such as flywheel, and battery energy storage system (BESS)). The MG Central Controller (MGCC) that connected on LV lateral substation that controls the MG centrally. To manage the micro-sources and load, the local controllers like Micro-Source Controller (MC) and Load Controller (LC) are used and interchange the required data along MGCC via a communication connection. LC is utilized to manage loads via local load shedding strategies under emergency situations and MC manages the real and reactive powers from micro-sources [39], [40].

The initial level of hierarchical control structure is the primary control also known as local control, which responds faster and is utilized to soothe the MG frequency and voltage via the correct distribution of the load between the units of DG [16]. In the MG the controller that are responsible for primary control are LCs and MCs. The secondary controller does corrective actions to eliminate voltage and frequency deviances that are present at the primary control level. In accordance with [39], [41], and [42], secondary level control can be used in both decentralized and centralized approaches (e.g. the MGCC may perform the secondary control centrally or the MC perform it locally).

Tertiary control copes the power flow among the utility grid and the MG in usual interconnected mode. Furthermore, the key function of it has as an economic management function and manage the features that enable optimum planning of the units of DG [9].

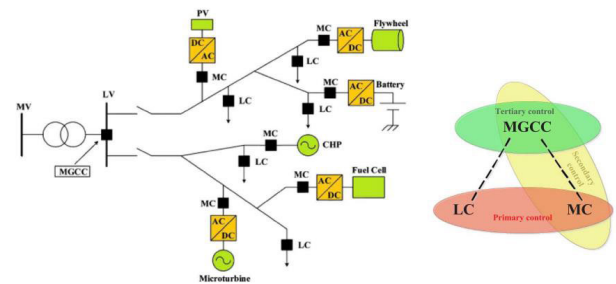

FIGURE 2. Typical LV MG and the relationship amongst the MG controllers [40].

A. PRIMARY LEVEL CONTROL IN MICROGRID

As mentioned in the preceding segment, the initial level control of the hierarchical control structure is the primary control. This level of control is mostly limited to the MG

and is utilized to manage current and voltage. Because of utilizing only local variables for processing this step may not give the performance of required system. To attain the wanted performance, higher-level controls interrelate with the primary control level utilizing their local variables. Mainly, these higher level controllers take primary level monitoring actions to improve their performance. There are two main categorizations for primary control of an island MG, comprising communication-based approaches and non-communication approaches. Techniques that are based on communication have some benefits, like a precise power distribution, good PQ, better transient reaction, and elimination of circulating current. Though, all of these techniques are expensive and complex and need control loops for high bandwidth communication connections. Non-communicating techniques rely on droop controlling which are using local measurements to manage the units of DG. These techniques have a lot of necessary properties, for example flexibility, extensibility, redundancy and ease of execution [43], [44]. Though, droop-based approaches have few disadvantages, like Imprecise power distribution, slow transient reaction, and circulating current between the converters. Figure 3 displays the classification of the primary controller classifications for an island MG [20], [23], [45], [46].

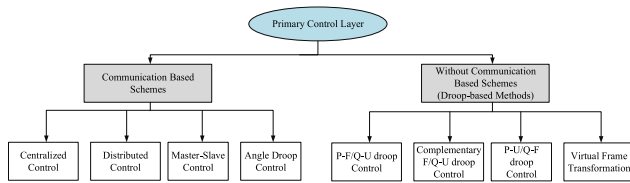

FIGURE 3. Control strategies for primary controller.

B. TERTIARY LEVEL CONTROL IN MICROGRID

Though the MG has two preliminary regulators for current and voltage supervision; To attain an efficient and optimal act of the MG, a supplementary control layer, such as tertiary regulator, necessary. Tertiary control may be implemented centrally or decentralized in a hierarchical control structure. Unlike the primary and the secondary controller levels, the tertiary controller system may encompass its scope further than the MG. The tertiary control level turn into the compulsory tool for energy and power supervision in a MG network. In spite of the smaller size of the MG compared to the traditional grid, the requisite to control power flow and manage energy is key to increasing whole efficacy. The succeeding ways are utilized in the tertiary controller for energy management: management of energy amid MG and traditional grid, within the MG bunch, and energy exchange between DGs of a MG in island mode. To provide optimum energy storage, planning of energy, managing energy flows and to minimize operating costs is the main aim of this level. The utilization of modest calculation algorithm and technique makes the tertiary control sluggish and inefficient as it deals with difficult calculations and shields nearly the entire MG network [23].

Before accepting a control strategy, three situations, such as the consistent, cost-effective and optimum state of network must be extremely deliberated. From these three constraints, two constraints, such as an optimum state and cost-effective is perceptively attained via utilizing the tertiary control layer. Every network wants to endure operating in an optimal situation, or close to an optimal situation. So, the tertiary control level utilizing a diversity of optimization methods to attain the above-mentioned objective. The optimization method utilizes adjusted inputs and difficult mathematical calculations to achieve the wanted optimum state of the network. In general, the three optimization algorithms, such as Genetic Algorithm, PSO and consensus procedure, used at the tertiary control level of the MG. Among these approaches, the consensus-based algorithm allows rapid convergence of the network's distributed agents towards a mutual agreement.

III. SECONDARY LEVEL CONTROL IN MICROGRID

At the primary layer when the MG controller uses the droop scheme, the error of steady state is non-zero; So, the recovery of frequency and voltage deviance and greater flexibility of secondary level structure have been discussed [47], [48]. The secondary layer has function like reliability and reduction of voltage and frequency deviances to determine the MG economic performance and operating points of the primary level control [49]. The secondary regulator establishes common coupling voltage point and exchange of power among the utility grid and the MG. For lessening of loss and PQ and lead to increasing economic benefits, determined the operational points of the secondary controller that are based on optimization principles [49], [50].

The secondary level control may be achieved in 3 different means: centralized [51], [52], decentralized and distributed [41], [53], [54], [55], [56]. Table 2 presented the secondary control categories. This organization illustrates the forms of secondary-level control approaches discussed in different articles, and the main characteristics of centralized, distributed, and decentralized control are summarized in Table 3. This helps to better understand and get information about this level from the controller.

A. STRUCTURE OF CENTRALIZED CONTROLLER IN THE MICROGRID

The centralized approaches assume that loads are located on common bus and that the secondary controller regulates the voltage of common bus around the mention value [70], [72]. Meanwhile this technique needs an extensive system of communication, that would be utilized to control and monitor the various MG features. The centralized approach makes it easy to import the DG into the MG without influencing the control database. Though, this is highly dependent on the MGCC and would be deliberated a serious restriction [30]. Meanwhile the entire calculations of control are done in the MG central controller, the failure would affect the full MG, so a standby system is needed to enhance the

TABLE 2. Classifications of types of the secondary layer control.

Secondary control of MG		
Centralized	Decentralized	Distributed
Estimation of Load [55]	Potential function [16] State of charge [57]	Distributed averaging [42] Consensus Algorithm [58]–[60]
	Life optimization of units of energy storage [61] Adaptive PI using neural network [64]	Networked control [62], [63] Distributed averaging PI [65] Feedback linearization [66] MAS [67], [68]

TABLE 3. Comparison of various classifications of secondary control kinds.

Secondary Control Types	Features								
	Reliability	DG Possession	Plug and play	Single point of failure	Communication burden	Unit coordination	Implementation difficulty	Flexibility	Computational cost
Centralized	Low	Single	Not Feasible	Yes	High	High	Easy	Very Low	High concentrated on the central controller
Decentralized	High	Multiple	Feasible	No	Very Low	Low	Easy	Very High	Low local controller using simply local info
Distributed	Medium-High	Multiple	Feasible	No	Medium	Medium	Complex	High	Medium local controllers using simply neighboring and local info

TABLE 4. Control technique utilized for the centralized control.

Control Techniques	Relevant reference	Control Level	Control method	Uses	Performance in the existence of communication interruptions
Model Predictive Control	[31]	Secondary Level	This method is depending on the system predictions and the future performance. This is also gives the mechanism of feedback.	Appropriate for networks that are highly reliant on the demand. Appropriate for networks that are highly reliant on the renewable energy production.	Model predictive Control are efficiently for systems like a secondary level control even during an intense situations where the delays in communication are complex and unknown
Droop control	[51]	Primary Level	In the droop control, an offline computation are performed, that is the beneficial approach.	Appropriate for the MG with restricted DG resources	Because of the time delays the controller utilizes the complicated potential functions to identify the perturbations
Prediction based memory control	[69]	Secondary Level	This method is rely on H_∞ predictions and control	Appropriate for in the time delay networks.	The robust controller that are predictor-based kept the better voltage regulation time-delayed networks

consistency [30]. The traditional secondary level control approaches utilized a centralized based structure containing of the Droop controller, central controller and an arithmetic section. These necessities lessen the flexibility and reliability of the MG and enhance its vulnerability to disruption, so as to the failure of single unit will cause the serious issue in the MG. Because of this, few distributed approaches are discussed [70], [71], [73].

Due to the delays in the links of communication at the control of MG the stability of system will be affected The

presence of a delays in the network of communication may generate uncertainty in the MG [74]. It displays the significance of keeping an adequate control network to eradicate delays effect in MG performance. Distributed control based on the MAS has given a favorable technique to eradicate the effect of time delay [69].

Figure 4 displays the network of centralized control. Few of the control techniques utilized for this are presented in the Table 4; as well as the benefits and drawbacks of centralized network are summarized in the Table 5.

TABLE 5. Pros and cons of the centralized control.

Pros of centralized control	References	Cons of centralized control	References
This control technique gives greater observability and controllability. Capability to inject DG to the MG without influencing the MG central controller.	[14]	Strong dependence on the central controller. Extensive network of communication origins time delay.	[14]
It's execution is straightforward and simple	[30]	Generated high costs through the high-bandwidth links of the communication	[70]
Low-cost strategy	[69]	This method also lacks expandability and flexibility	[70]
It has the capability to gather information from all units	[69]	This structure need a complicated network of communication.	[71]
		It is highly adapted to small scale distinct user MGs.	[54]

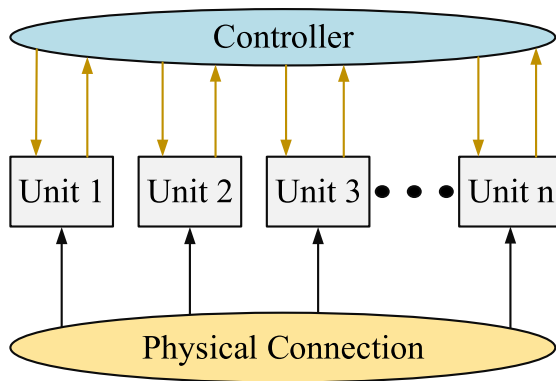

FIGURE 4. Schematic figure of centralized control method.

B. DISTRIBUTED CONTROL SYSTEM IN THE MICROGRID

In addition to lessening the utilization of communication system the distributed controller has more benefits as compared to the centralized control system. This structure was therefore developed as a suitable technique to control MGs [10]. The traditional distributed control structure is shown in Figure 5.

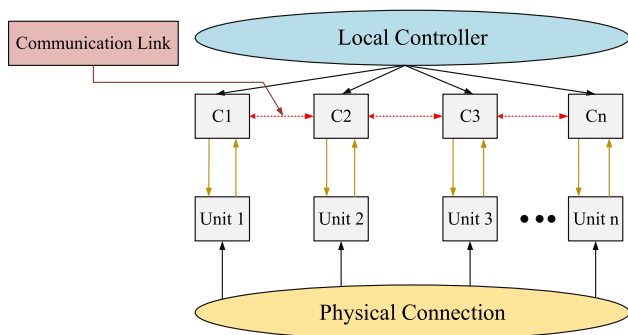

FIGURE 5. Schematic figure of the distributed control method.

To remove the requirement for advanced control a lot of research have been done and a completely distributed control framework is proposed, as illustrated in Figure 6 [75]. In general, there are three challenges for distributed MG control:

- The initial one is to reestablish the frequency and voltage of heterogeneous units of DG to baseline values

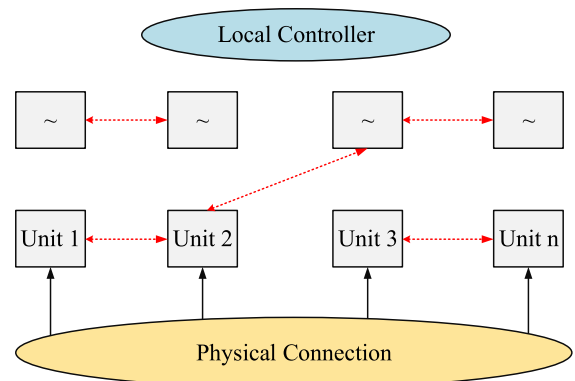

FIGURE 6. Fully distributed structure.

instantaneously and swiftly in the completely distributed technique;

- The secondary one is exact distribution of power accordance to the distributed generators power capability;
- The third is autonomous of parameters of the MG [76], [77].

It gives a vigorous secondary layer control structure intended to boost synchronization procedure and make sure consensus in the finite time [78]. The Summary of this control approaches are illustrated in the Table 6. The comparison and overview of the secondary level control systems shows scholarly concern in escalating decentralized and distributed network in latest papers. The main cause for this may be seen as significance of decreasing the dependency of control framework on communication system and creating the MG gateway resilient to tasks of communication.

Amongst the distributed approaches, the consensus algorithm is recognized as an appropriate method for the distributed control structure. In many surveys related to the distributed technique, consensus has been utilized. This procedure is described in a separate segment as follows.

1) CONSENSUS-BASED TECHNIQUES

The most popular distributed method that is used for controlling MG for many years is Consensus algorithm. This procedure is capable to coordinate DG in a MG via sharing

TABLE 6. Review of the distributed control techniques.

Control Methods	Name of Method	Control Level	Relevant reference	Employment Complexity	Other attributes
Distributed level Control	Droop	Primary Level	[63], [65], [66]	Easy	No dependence on communication network
	MPC	Secondary Level	[67], [68], [70]	Complex	It is effective for MGs with a huge number of resources
	SMC	Secondary Level	[70]–[74]	Moderate	The system closed-loop reactions has no consideration to uncertainties (non-linearity, perturbations, and parameters of mode)
	Event Triggered	Secondary Level	[63], [65]–[68][69]–[74][79]–[82][83]	Complex	Decrease the updates of control signal. Decrease the probability of loss of data during the transmission of data.
	H_∞	Secondary Level	[84]–[86]	Complex	Appropriate for the delayed networks

data. In this technique, the classification of communication relations and information exchange guidelines is created on the theory of multi agent system [87], [88], [89], [90]. How to design an appropriate controller so that every agent may attain a common value in consensus algorithm that are based on multi agent system is a main problem. Extensive agent involvement creates management and control of MAS expensive or unfeasible. So, developed the distributed control by utilizing the exchange of local data among neighbors via shared networks of the communication. In the latest years numerous researches have been done on the distributed consensus based control for the MAS [90], [91]. In the literature, the usage of other kinds of the consensus approaches has also been deliberated [92], [93], [94], [95], [96], [97], [98], [99], [100], [101], [102], [103], [104], [105], [106], summarized in Figure 7.

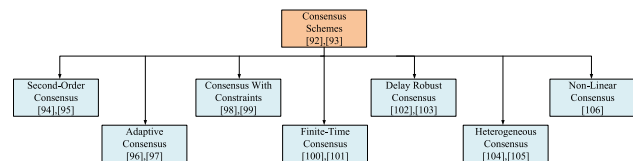

FIGURE 7. Categories of consensus techniques.

Event-triggered Technique: In the traditional consensus process method, the distributed production control structures has admittance to control the signals and measure data via communication system. Because of the limited communication resources, it will be significant to save computer resources. Because of the Nonstop utilization of network of the communication may increase communication interruptions e.g. extensive delays, rise packet loss and lessen performance, and inescapably diminish system steadiness,

TABLE 7. Pros and cons of the event-triggering control strategy.

Strategy	Disadvantages		
	High Frequency of the Controller Updates	Concerns on the Constant Communication	Restrictions of network Dynamics
Model-based event-triggering	[115]–[120]	-	-
Event-based sampling scheme	[107], [121]–[128]	[107], [121], [129]–[134]	[107], [123]–[126], [129]–[134]
Sampled-data-based event-triggered	[135]–[138]	-	[135]–[138]
Self-triggered sampling	[139]–[141]	-	-

reliability and performance. Event-based consensus control is a positive way out to maintain the control function of MAS. It also decreases excessive use of computing and communication resources [107], [108].

The event-based technique is progressively applied at the MG secondary level control, as it keeps constancy and decreases the interchange of data among DG units. To examine the control of event-trigger the consensus technique is using, this structure may be separated into two forms:

- The primary frame is model based event triggering technique. In it, the event triggered command is described that are rely on the estimated errors [109].
- The second frame is the data sampling based on events, which involves techniques like event based sampling strategy, sample data-driven sampling strategy [110], and self-commissioned sampling strategy [111]

This network has benefits and drawbacks, that are presented in Table 7. With event-driven technique, command

TABLE 8. Control approaches utilized for decentralized system control.

Control technique	Reference	Performance Control method	Uses	Performance in existence of delays of communication
Adaptive decentralized droop controller	[143]	This technique is static droop features based associated with the adaptive transitory droop function	At the various situations, the control system keeps the stability and dynamics of every unit of inverter.	Not investigated
Consensus	[116]	Rely on the state feedback. Lacking requiring constant communication amongst agents.	The event-triggered consensus problematic is analyzed for MAS using the common linear dynamics in the common directed graph	Not investigated
Event-Triggered	[72]	Control will detect the predefined event function	Networks of which there is delay in time	It is noticed that the if the delays in communication increases then the reaction of network turn into more oscillatory

inputs are generated when events occur. If the system state (bus voltages or converter currents) diverges from the target value (error band) by a certain threshold, this is evaluated as the event. It is alike to time triggering, however event triggering may decrease stress of communication, power exhaustion, and CPU load through taking samples rely on the generated events.

Reference [112] proposed a novel distributed secondary level control based on event triggering approach for distinct bus DC MGs that could enable voltage regulation and precise current distribution at equal values of line resistances. Its efficiency must be checked with different line impedances. In [113], an H_∞ event-triggered distributed consensus algorithm was presented to attain accurate current exchange. This algorithm gives proportional load distribution at the expense of voltage regulation. In [76], a new distributed secondary control approach with event-triggered signal transmission was proposed. Though, this technique will not work if the voltages of DC bus is not available to converters. Furthermore, simply resistive loads are taken into account. Finite-time consensus, as applied in [101], permits convergence in the limited number of steps, though debugging and deals uncertainties can introduce reactive chatter. Fixed-time consensus is utilized in [114]. Fixed time has better scalability and convergence as compared to the event based techniques.

Consensus-based secondary control methods may attain a voltage swing term and a current sharing correction term using compact communication links. A network with compact communication associations may require greater time to converge, and the convergence time may be decreased with the system fully communicated. Therefore, there is always a trade-off between the number of communication linkages and the convergence speed.

C. DECENTRALIZED CONTROL SYSTEM IN MICROGRID

The decentralized control system works on the local measures basis. Contrasting a centralized control system in the decentralized controllers, every DG entity is an independent

TABLE 9. Graphs types for network modelling of communication in MGs.

Graph Theory			
Type	Advantage	Disadvantage	Relevant Reference
Directed	Unbalanced characteristics of directed graph Less demand for the communication network.	Complicated	[94]–[96]
Undirected	Communication apparatus. Low resource cost. High scalability. Robustness against delay.	Asymmetric property of directed graph	[97], [102]

entity [79]. So, in this control, the requirement for a network of the communication is compact and the control is local [80]. Simply local data is utilized and the network may continue to operate even if multiple agents malfunction as compared to the centralized control system. Because of the lack of the communication connection, this control approach is deliberated the utmost reliable, regardless of its limitations. It is suitable for reducing the complication of communication and data processing. This control has 3 core branches, specifically consensus-based processes, MAS, and their amalgamations. In more recent research, the decentralized control system has been established utilizing network of MAS. A multi-agent system concept based decentralized control for MGs was presented in [81] and established in [84]. Figure 8 displays decentralized control method. The Table 8 presents the analysis carried out on this control. Though, it cannot be able to efficiently cope all the control objectives because of the absence of communication [142]. Consequently, the distributed control system is developed with the benefits of both decentralized and centralized processes. The above segment defines the characteristics of the distributed control system.

IV. COMMUNICATION SYSTEM

The communication systems study was inspected in two portions, modeling communication systems utilizing graph theory (GA) and the communication procedures.

TABLE 10. Control approaches utilized against communication disturbances.

Control Schemes	Reference	Communication disruption	Effect of communication disturbances on MG
Event-triggered SMC-virtual leader	[167]	Network noise	The noise of network may expressively affect frequency and voltage of control of the MG
Noise-resilient controller	[168]	Gaussian noise	Communication connections are exposed to ambiguous noises, that may expressively affect the MG control synchronization performance
Distributed noise robust	[169]	Additive noise form	The communication connections are exposed to additive communication noise, that may expressively influence the frequency and voltage of MG control
Fully distributed cooperative	[170]	Packet losses	The packet losses in communication takes toward lengthier transient amendable time for distributed generators
Cooperative control	[171], [172]	Measurement noises Link failure	The failure of links also effects on transient control behavior and deteriorates it. Produced uncertainty in the voltage of MG.
Cyber-physical collaborative control	[173]	Packet losses	The packet loss also has an influence on data of communication. Furthermore, greater rate of losses will produce the disruption of the communication

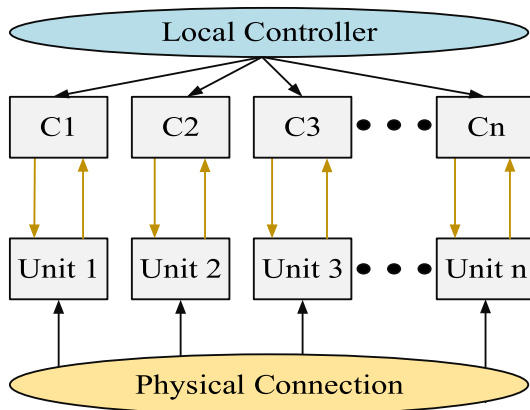

FIGURE 8. Schematic figure of decentralized control technique.

A. THE GRAPH THEORY

As the islanded MG using the several DGs, network of communication between units of DG may be modeled using the graph. In the graph of MG, nodes specify the distributed generators and edge of their communication connections [144]. MAS is thus represented in the form of a graph, where $V = \{v_1, v_2, v_3 \dots v_n\}$ is the set of agents, $\varepsilon \subseteq V \times V$, $\varepsilon = \{e_1, e_2 \dots e_n\}$ is a set of edges, The associated adjacency matrix $A = [a_{ij}] \in R_{n \times n}$ with $a_{ii} = 0$. The Laplacian is specified via $L = D - A$; Where D is the degree matrix

and $L = L_{ij} \in R_{n \times n}$, L is semidefinite with positive symmetry [145]. In Table 9, the structure of the graph is separated into two subdivisions.

B. COMMUNICATION PROTOCOL

For the good performance of the MG, as well as the adequate control system, option of a communication procedure may have an important influence on the behavior of the MG. Especially, the communication procedure should be consistent by the control objectives of the MG and should not complex implementation or rise costs. In latest studies on MG control, different communication procedures have been analyzed with the goal of lessening price and accelerating the growth of MGs [146], [147]. In [146], IEC 61850 based communication network was utilized as an appropriate and favorable way out to keep security of network and increase the reliability of MGs.

The communication network study may be allocated into two forms, utilizing wireless and wired [148]. The Wired systems like fiber and power lines are subject to extra interference of communication and noise than wireless modes because of the environmental situations. Utilization of wired approaches may also take to the difficulty of communication system and restrict it to a particular location. So, wireless systems like WiMax, Wi-Fi, SigFox, ZigBee seem to be more cost effective and responsive with proper control structure to avoid communication disruptions [148], [149], [150].

TABLE 11. The consequence of secondary control approaches on the time delay in MG.

Techniques	References	Category of the time delay	Behavior of the MG in existence of delay	Limits of Delay	Effect of presented controller
Event triggering	[174]	Communication connection time delay	Deteriorating of MG behavior in keeping constancy	Time of the Simulation (0.1 s)	The results of simulation endorse the efficiency of presented method against huge time delays. Though, in presented technique, rate of convergence speed slow
	[112]	Communication connection time delay	Deteriorating of behaviour of MG in keeping the stability.	Simulation (15 ms)	The presented control is resilient to time postponements of lesser than the 15 (ms). Though, by increase in delay, the network turn into unstable.
Consensus	[175]	Communication linkage time delay	Beforehand the consensus is attained, the RMS current has few fluctuations	Simulation (1 ms)	This framework illustrates the good behavior of consensus procedures in expressions of opposition to the time postponement in the small time
	[164]	Communication link time delay	Increase in the delays of communication causes the greater fluctuations and slower the agreement rates.	Simulation (10 ms)	In contrast to present controllers, the presented controller provide a quicker rate of convergence rely on finite-time consensus procedure.
	[165]	Communication connection time interruption	The closed-loop network reaction turn into oscillatory and the convergence come to be slow in communication time interruptions	Simulation (800 ms)	Demonstrates the important sturdiness against the load turbulences, and positively endures, small in addition to large, communication time-delays.
	[176]	Communication linkage time delay	The delays in communication will decrease the control network convergence speed	Simulation (400 ms)	Results of simulation prove the efficiency of the presented method, particularly, it has strong sturdiness to communication delay.
MPC	[174]	constant communication linkage time delay	DMPC depend on the voltage observer-may not attain precise voltage retrieval in time delay.	Simulation (0.2 s)	As compared to the traditional control strategy, this strategy may completely take into consideration the restraints produced via the time delay and attain the amendable stability among power sharing and voltage of node.
	[50]	unknown and Variable communication delays	Uneven eigenvalues	Simulation (1.11 s)	The secondary control network based on MAS is significantly more vigorous in terms of extreme delay allowable
SMC	[177]	Time-varying delay	The delays in time will create control signals for the reference voltage graphs postponed, that produces phase shift among voltage of MG and voltage of reference LPG	Time-varying.	The correctness of the arbitrary delay approximation $\tau(t)$ and MG states approximation $x(t)$ may adaptively enhanced via control of SMC.
	[178]	Time-varying delay	Estimated stochastic delays.	Time-varying.	It illustrated the advantages for dealing by extensive time interruptions utilizing the predictive framework and the sturdiness of theory of sliding mode.

Communication failures in the wireless systems are discussed in the following segment.

C. COMMUNICATION DISTURBANCES

It is beforehand found that distributed system has greater enactment as compared to the other control framework; Though, because of the reliance on distributed framework of communication system, MGs are subject to communication and interference limitations. In that sense, the communication limitations like delays, packet losses, cyber-attacks,

communication system failures and noise are the main communication turbulences in MG that lead toward the loss of synchronization of the physical parameters or even the unsteadiness of the MG [144]. Consequently, it is important to design a control structure capable of maintaining the stability of the MG in event of turbulences in the communication systems [145], [151], [152]. The Consensus-based distributed level control has been deliberated like an appropriate method for communication limitations, therefore consensus-based control that takes into account delays and time-varying noise

is introduced in [153]. Additional method to evading communication limitations is to utilize time-based graph theory method; In [154], utilizing communication system modeling via time-varying graph theory, the MG was expressively enhanced against the loss of data, communication system failure and the time lag.

Along with the disruptions produced via communication system, cyber-attacks may disturb performance of MG in such a means that MG may fail, which is discussed in [155] through Software Defined Networking (SDN). Communication system failure is one of the turbulences that affect behavior of MG controller, that is discussed in [156], the proposed method for modernization of the lines of communication. The Table 10 presents control procedures utilized in existence of the communication failures. Amongst the communication disorders research, researchers have investigated time lag in latest studies because of its significance in keeping constancy. Consequently, it is discussed in below segment.

1) COMMUNICATION DELAYS IN THE SECONDARY LEVEL CONTROL

The transfer of data over communication systems for example WiMax, WiFi, Internet, ZigBee, and Ethernet in MGs is linked by delays [157], [158]. In the worst case, time lag in communication networks can lead to poor and unstable MG performance. To study delay in networks of communication, it may be separated into two sets; communication and input delay [159].

The distributed level control framework is an efficient technique to control MGs in the existence of delays [160]. Though, this framework has restricted resistance to time-outs. Therefore, it is difficult to find the delay margin for the MG to work well. Taylor series [161], linear matrix inequality [162], [163], simulation-based [164], [165], experiment/HIL [166] are famous approaches to determine the margin of delay in MGs. Moreover, in [166], an extensive study was conducted on the approaches to determine the delay margin in MGs. The Table 11 presents the four control systems to inspect kinds of delays and calculation of the delay margin and impact of the control technique on the delay time.

V. CONCLUSION

The key challenges of MGs are getting the right controller. In present work, assembly of secondary controller was examined using the description of the three different levels of control as primary, secondary, and tertiary and it has been revealed that each of them imposes different demands on the performance of communication. During analysis, it was developing that primary layer is the time-critical process which provides instantaneous control of frequency and voltage, thus non-communication control approaches are used. A secondary control level, contrasting primary control level, is highly reliant on communication system. According to communication system, this control layer has been distributed into three configurations; centralized

control, distributed control and decentralized control. Evaluation of control configurations displayed that the distributed controller has numerous benefits over centralized strategy (such as increased consistency and confrontation to equipment collapse), it can need extra complex information transmission over communication lines. The dependency of the communication system on the distributed controller assembly needs an analysis of the control performance in the event of communication interruptions. Therefore, "in what way to soothe data transmission during communication failures in the restricted system capitals of the MG" is also one of the key tasks of MG control. Lastly, this article providing the global view of secondary layer in relation to communication system in the MG and the performance of controllers in the event of communication failures. It is suggested that communication outbreaks and their influence on secondary layer assembly and the MG behavior be examined in upcoming studies.

REFERENCES

- [1] H. Xie, S. Zheng, and M. Ni, "Microgrid development in China: A method for renewable energy and energy storage capacity configuration in a megawatt-level isolated microgrid," *IEEE Electr. Mag.*, vol. 5, no. 2, pp. 28–35, Jun. 2017, doi: [10.1109/MELE.2017.2685818](https://doi.org/10.1109/MELE.2017.2685818).
- [2] W. Gu, G. Lou, W. Tan, and X. Yuan, "A nonlinear state estimator-based decentralized secondary voltage control scheme for autonomous microgrids," *IEEE Trans. Power Syst.*, vol. 32, no. 6, pp. 4794–4804, Nov. 2017, doi: [10.1109/TPWRS.2017.2676181](https://doi.org/10.1109/TPWRS.2017.2676181).
- [3] N. Zanib, M. Batool, S. Riaz, and F. Nawaz, "Performance analysis of renewable energy based distributed generation system using ANN tuned UPQC," *IEEE Access*, vol. 10, pp. 110034–110049, 2022, doi: [10.1109/ACCESS.2022.3213948](https://doi.org/10.1109/ACCESS.2022.3213948).
- [4] T. Lei, S. Riaz, N. Zanib, M. Batool, F. Pan, and S. Zhang, "Performance analysis of grid-connected distributed generation system integrating a hybrid wind-PV farm using UPQC," *Complexity*, vol. 2022, pp. 1–14, Mar. 2022.
- [5] N. Zanib, "Analysis and power quality improvement in hybrid distributed generation system with utilization of unified power quality conditioner," *Comput. Model. Eng. Sci.*, vol. 134, pp. 1105–1136, May 2022, doi: [10.32604/cmescs.2022.021676](https://doi.org/10.32604/cmescs.2022.021676).
- [6] A. Nawaz, M. Zhou, J. Wu, and C. Long, "A comprehensive review on energy management, demand response, and coordination schemes utilization in multi-microgrids network," *Appl. Energy*, vol. 323, Oct. 2022, Art. no. 119596, doi: [10.1016/j.apenergy.2022.119596](https://doi.org/10.1016/j.apenergy.2022.119596).
- [7] K. Singh, M. Amir, F. Ahmad, and S. S. Refaat, "Enhancement of frequency control for stand-alone multi-microgrids," *IEEE Access*, vol. 9, pp. 79128–79142, 2021, doi: [10.1109/ACCESS.2021.3083960](https://doi.org/10.1109/ACCESS.2021.3083960).
- [8] T. R. Oliveira, W. W. A. Gonçalves Silva, and P. F. Donoso-Garcia, "Distributed secondary level control for energy storage management in DC microgrids," *IEEE Trans. Smart Grid*, vol. 8, no. 6, pp. 2597–2607, Nov. 2017, doi: [10.1109/TSG.2016.2531503](https://doi.org/10.1109/TSG.2016.2531503).
- [9] L. Che, M. Khodayar, and M. Shahidehpour, "Only connect: Microgrids for distribution system restoration," *IEEE Power Energy Mag.*, vol. 12, no. 1, pp. 70–81, Jan. 2014, doi: [10.1109/MPE.2013.2286317](https://doi.org/10.1109/MPE.2013.2286317).
- [10] Z. Chmiel and S. C. Bhattacharyya, "Analysis of off-grid electricity system at Isle of Eigg (Scotland): Lessons for developing countries," *Renew. Energy*, vol. 81, pp. 578–588, Sep. 2015, doi: [10.1016/j.renene.2015.03.061](https://doi.org/10.1016/j.renene.2015.03.061).
- [11] F. Mohammadi, B. Mohammadi-Ivatloo, G. B. Gharehpetian, M. H. Ali, W. Wei, O. Erdinç, and M. Shirkhani, "Robust control strategies for microgrids: A review," *IEEE Syst. J.*, vol. 16, no. 2, pp. 2401–2412, Jun. 2022, doi: [10.1109/JSYST.2021.3077213](https://doi.org/10.1109/JSYST.2021.3077213).
- [12] S. K. Sahoo, A. K. Sinha, and N. K. Kishore, "Control techniques in AC, DC, and hybrid AC-DC microgrid: A review," *IEEE J. Emerg. Sel. Topics Power Electron.*, vol. 6, no. 2, pp. 738–759, Jun. 2018, doi: [10.1109/JESTPE.2017.2786588](https://doi.org/10.1109/JESTPE.2017.2786588).

- [13] A. Cagnano, E. De Tuglie, and P. Mancarella, "Microgrids: Overview and guidelines for practical implementations and operation," *Appl. Energy*, vol. 258, Jan. 2020, Art. no. 114039, doi: [10.1016/J.APENERGY.2019.114039](https://doi.org/10.1016/J.APENERGY.2019.114039).
- [14] J. M. Rey, P. Martí, M. Velasco, J. Miret, and M. Castilla, "Secondary switched control with no communications for islanded microgrids," *IEEE Trans. Ind. Electron.*, vol. 64, no. 11, pp. 8534–8545, Nov. 2017, doi: [10.1109/TIE.2017.2703669](https://doi.org/10.1109/TIE.2017.2703669).
- [15] S. Peyghami, H. Mokhtari, and F. Blaabjerg, "Decentralized load sharing in a low-voltage direct current microgrid with an adaptive droop approach based on a superimposed frequency," *IEEE J. Emerg. Sel. Topics Power Electron.*, vol. 5, no. 3, pp. 1205–1215, Sep. 2017, doi: [10.1109/JESTPE.2017.2674300](https://doi.org/10.1109/JESTPE.2017.2674300).
- [16] A. Mehrizi-Sani and R. Iravani, "Potential-function based control of a microgrid in islanded and grid-connected modes," *IEEE Trans. Power Syst.*, vol. 25, no. 4, pp. 1883–1891, Nov. 2010, doi: [10.1109/TPWRS.2010.2045773](https://doi.org/10.1109/TPWRS.2010.2045773).
- [17] T. Dragicevic, "Model predictive control of power converters for robust and fast operation of AC microgrids," *IEEE Trans. Power Electron.*, vol. 33, no. 7, pp. 6304–6317, Jul. 2018, doi: [10.1109/TPEL.2017.2744986](https://doi.org/10.1109/TPEL.2017.2744986).
- [18] I. Serban, S. Céspedes, C. Marinescu, C. A. Azurdia-Meza, J. S. Gómez, and D. S. Hueichapan, "Communication requirements in microgrids: A practical survey," *IEEE Access*, vol. 8, pp. 47694–47712, 2020, doi: [10.1109/ACCESS.2020.2977928](https://doi.org/10.1109/ACCESS.2020.2977928).
- [19] E. Espina, J. Llanos, C. Burgos-Mellado, R. Cárdenas-Dobson, M. Martínez-Gómez, and D. Sáez, "Distributed control strategies for microgrids: An overview," *IEEE Access*, vol. 8, pp. 193412–193448, 2020, doi: [10.1109/ACCESS.2020.3032378](https://doi.org/10.1109/ACCESS.2020.3032378).
- [20] D. E. Olivares, A. Mehrizi-Sani, A. H. Etemadi, C. A. Cañizares, R. Iravani, M. Kazerani, A. H. Hajimiragha, O. Gomis-Bellmunt, M. Saadedifard, R. Palma-Behnke, G. A. Jiménez-Estévez, and N. D. Hatziargyriou, "Trends in microgrid control," *IEEE Trans. Smart Grid*, vol. 5, no. 4, pp. 1905–1919, Jul. 2014, doi: [10.1109/TSG.2013.2295514](https://doi.org/10.1109/TSG.2013.2295514).
- [21] J. C. Vasquez, J. M. Guerrero, J. Miret, M. Castilla, and L. G. de Vicuña, "Hierarchical control of intelligent microgrids," *IEEE Ind. Electron. Mag.*, vol. 4, no. 4, pp. 23–29, Dec. 2010, doi: [10.1109/MIE.2010.938720](https://doi.org/10.1109/MIE.2010.938720).
- [22] Y. Khayat, Q. Shafiee, R. Heydari, M. Naderi, T. Dragicevic, J. W. Simpson-Porco, F. Dörfler, M. Fathi, F. Blaabjerg, J. M. Guerrero, and H. Bevrani, "On the secondary control architectures of AC microgrids: An overview," *IEEE Trans. Power Electron.*, vol. 35, no. 6, pp. 6482–6500, Jun. 2020, doi: [10.1109/TPEL.2019.2951694](https://doi.org/10.1109/TPEL.2019.2951694).
- [23] A. Abhishek, A. Ranjan, S. Devassy, B. K. Verma, S. K. Ram, and A. K. Dhakar, "Review of hierarchical control strategies for DC microgrid," *IET Renew. Power Gener.*, vol. 14, no. 10, pp. 1631–1640, Jul. 2020, doi: [10.1049/iet-rpg.2019.1136](https://doi.org/10.1049/iet-rpg.2019.1136).
- [24] Y. Sabri, N. El Kamoun, and F. Lakrami, "A survey: Centralized, decentralized, and distributed control scheme in smart grid systems," in *Proc. 7th Medit. Congr. Telecommun. (CMT)*, Oct. 2019, pp. 1–11, doi: [10.1109/CMT.2019.8931370](https://doi.org/10.1109/CMT.2019.8931370).
- [25] Y. Khayat, M. Naderi, Q. Shafiee, Y. Batmani, M. Fathi, J. M. Guerrero, and H. Bevrani, "Decentralized optimal frequency control in autonomous microgrids," *IEEE Trans. Power Syst.*, vol. 34, no. 3, pp. 2345–2353, May 2019, doi: [10.1109/TPWRS.2018.2889671](https://doi.org/10.1109/TPWRS.2018.2889671).
- [26] M. Castilla, A. Camacho, P. Martí, M. Velasco, and M. M. Ghahderijani, "Impact of clock drifts on communication-free secondary control schemes for inverter-based islanded microgrids," *IEEE Trans. Ind. Electron.*, vol. 65, no. 6, pp. 4739–4749, Jun. 2018, doi: [10.1109/TIE.2017.2772178](https://doi.org/10.1109/TIE.2017.2772178).
- [27] P. Martí, J. Torres-Martínez, C. X. Rosero, M. Velasco, J. Miret, and M. Castilla, "Analysis of the effect of clock drifts on frequency regulation and power sharing in inverter-based islanded microgrids," *IEEE Trans. Power Electron.*, vol. 33, no. 12, pp. 10363–10379, Dec. 2018, doi: [10.1109/TPEL.2018.2805368](https://doi.org/10.1109/TPEL.2018.2805368).
- [28] G. Lou, W. Gu, Y. Xu, W. Jin, and X. Du, "Stability robustness for secondary voltage control in autonomous microgrids with consideration of communication delays," *IEEE Trans. Power Syst.*, vol. 33, no. 4, pp. 4164–4178, Jul. 2018, doi: [10.1109/TPWRS.2017.2782243](https://doi.org/10.1109/TPWRS.2017.2782243).
- [29] M. Chen and X. Xiao, "Secondary voltage control in islanded microgrids using event-triggered control," *IET Gener., Transmiss. Distrib.*, vol. 12, no. 8, pp. 1872–1878, Apr. 2018, doi: [10.1049/IET-GTD.2017.0698](https://doi.org/10.1049/IET-GTD.2017.0698).
- [30] S. Sahoo and S. Mishra, "An adaptive event-triggered communication-based distributed secondary control for DC microgrids," *IEEE Trans. Smart Grid*, vol. 9, no. 6, pp. 6674–6683, Nov. 2018, doi: [10.1109/TSG.2017.2717936](https://doi.org/10.1109/TSG.2017.2717936).
- [31] K. T. Tan, X. Y. Peng, P. L. So, Y. C. Chu, and M. Z. Q. Chen, "Centralized control for parallel operation of distributed generation inverters in microgrids," *IEEE Trans. Smart Grid*, vol. 3, no. 4, pp. 1977–1987, Dec. 2012, doi: [10.1109/TSG.2012.2205952](https://doi.org/10.1109/TSG.2012.2205952).
- [32] Y. Zhang, A. M. Shotorbani, L. Wang, and B. Mohammadi-Ivatloo, "Distributed secondary control of a microgrid with a generalized PI finite-time controller," *IEEE Open Access J. Power Energy*, vol. 8, pp. 57–67, 2021, doi: [10.1109/OAJPE.2021.3056507](https://doi.org/10.1109/OAJPE.2021.3056507).
- [33] Q. Li, C. Peng, M. Wang, M. Chen, J. M. Guerrero, and D. Abbott, "Distributed secondary control and management of islanded microgrids via dynamic weights," *IEEE Trans. Smart Grid*, vol. 10, no. 2, pp. 2196–2207, Mar. 2019, doi: [10.1109/TSG.2018.2791398](https://doi.org/10.1109/TSG.2018.2791398).
- [34] A. A. Memon and K. Kauhaniemi, "A critical review of AC microgrid protection issues and available solutions," *Electric Power Syst. Res.*, vol. 129, pp. 23–31, Dec. 2015, doi: [10.1016/J.EPSR.2015.07.006](https://doi.org/10.1016/J.EPSR.2015.07.006).
- [35] M. Stadler, G. Cardoso, S. Mashayekh, T. Forget, N. DeForest, A. Agarwal, and A. Schönbein, "Value streams in microgrids: A literature review," *Appl. Energy*, vol. 162, pp. 980–989, Jan. 2016, doi: [10.1016/J.APENERGY.2015.10.081](https://doi.org/10.1016/J.APENERGY.2015.10.081).
- [36] Y. Han, H. Li, P. Shen, E. A. A. Coelho, and J. M. Guerrero, "Review of active and reactive power sharing strategies in hierarchical controlled microgrids," *IEEE Trans. Power Electron.*, vol. 32, no. 3, pp. 2427–2451, Mar. 2017, doi: [10.1109/TPEL.2016.2569597](https://doi.org/10.1109/TPEL.2016.2569597).
- [37] E. Unamuno and J. A. Barrena, "Hybrid AC/DC microgrids—Part II: Review and classification of control strategies," *Renew. Sustain. Energy Rev.*, vol. 52, pp. 1123–1134, Dec. 2015, doi: [10.1016/J.RSER.2015.07.186](https://doi.org/10.1016/J.RSER.2015.07.186).
- [38] M. S. Mahmoud, S. A. Hussain, and M. A. Abido, "Modeling and control of microgrid: An overview," *J. Franklin Inst.*, vol. 351, no. 5, pp. 2822–2859, May 2014, doi: [10.1016/J.JFRANKLIN.2014.01.016](https://doi.org/10.1016/J.JFRANKLIN.2014.01.016).
- [39] J. A. P. Lopes, C. L. Moreira, and A. G. Madureira, "Defining control strategies for MicroGrids islanded operation," *IEEE Trans. Power Syst.*, vol. 21, no. 2, pp. 916–924, May 2006, doi: [10.1109/TPWRS.2006.873018](https://doi.org/10.1109/TPWRS.2006.873018).
- [40] E. Rokrok, M. Shafiee-Khah, and J. P. S. Catalão, "Review of primary voltage and frequency control methods for inverter-based islanded microgrids with distributed generation," *Renew. Sustain. Energy Rev.*, vol. 82, pp. 3225–3235, Feb. 2018, doi: [10.1016/j.rser.2017.10.022](https://doi.org/10.1016/j.rser.2017.10.022).
- [41] Q. Shafiee, J. M. Guerrero, and J. C. Vasquez, "Distributed secondary control for islanded microgrids—A novel approach," *IEEE Trans. Power Electron.*, vol. 29, no. 2, pp. 1018–1031, Feb. 2014, doi: [10.1109/TPEL.2013.2259506](https://doi.org/10.1109/TPEL.2013.2259506).
- [42] J. W. Simpson-Porco, Q. Shafiee, F. Dörfler, J. C. Vasquez, J. M. Guerrero, and F. Bullo, "Secondary frequency and voltage control of islanded microgrids via distributed averaging," *IEEE Trans. Ind. Electron.*, vol. 62, no. 11, pp. 7025–7038, Nov. 2015, doi: [10.1109/TIE.2015.2436879](https://doi.org/10.1109/TIE.2015.2436879).
- [43] J. M. Guerrero, J. C. Vasquez, J. Matas, L. G. de Vicuña, and M. Castilla, "Hierarchical control of droop-controlled AC and DC microgrids—A general approach toward standardization," *IEEE Trans. Ind. Electron.*, vol. 58, no. 1, pp. 158–172, Jan. 2011, doi: [10.1109/TIE.2010.2066534](https://doi.org/10.1109/TIE.2010.2066534).
- [44] J. M. Guerrero, M. Chandorkar, T.-L. Lee, and P. C. Loh, "Advanced control architectures for intelligent Microgrids—Part I: Decentralized and hierarchical control," *IEEE Trans. Ind. Electron.*, vol. 60, no. 4, pp. 1254–1262, Apr. 2013, doi: [10.1109/TIE.2012.2194969](https://doi.org/10.1109/TIE.2012.2194969).
- [45] S. Islam, S. Agarwal, A. B. Shyam, A. Ingle, S. Thomas, S. Anand, and S. R. Sahoo, "Ideal current-based distributed control to compensate line impedance in DC microgrid," *IET Power Electron.*, vol. 11, no. 7, pp. 1178–1186, Jun. 2018, doi: [10.1049/IET-PEL.2017.0531](https://doi.org/10.1049/IET-PEL.2017.0531).
- [46] Z. Jin, L. Meng, J. C. Vasquez, and J. M. Guerrero, "Frequency-division power sharing and hierarchical control design for DC shipboard microgrids with hybrid energy storage systems," in *Proc. IEEE Appl. Power Electron. Conf. Expo. (APEC)*, Mar. 2017, pp. 3661–3668, doi: [10.1109/APEC.2017.7931224](https://doi.org/10.1109/APEC.2017.7931224).
- [47] N. Sheykhi, A. Salami, J. M. Guerrero, G. D. Agundis-Tinajero, and T. Faghihi, "A comprehensive review on telecommunication challenges of microgrids secondary control," *Int. J. Electr. Power Energy Syst.*, vol. 140, Sep. 2022, Art. no. 108081, doi: [10.1016/j.ijepes.2022.108081](https://doi.org/10.1016/j.ijepes.2022.108081).

- [48] I. U. Nutkani, W. Peng, L. P. Chiang, and F. Blaabjerg, "Secondary droop for frequency and voltage restoration in microgrids," in *Proc. 17th Eur. Conf. Power Electron. Appl. (EPE ECCE-Eur.)*, Sep. 2015, pp. 1–7, doi: [10.1109/EPE.2015.7309457](https://doi.org/10.1109/EPE.2015.7309457).
- [49] T. L. Vandoorn, J. D. M. De Kooning, B. Meersman, and L. Vandevelde, "Communication-based secondary control in microgrids with voltage-based droop control," in *Proc. PES T&D*, May 2012, pp. 1–6, doi: [10.1109/TDC.2012.6281436](https://doi.org/10.1109/TDC.2012.6281436).
- [50] C. Ahumada, R. Cárdenas, D. Sáez, and J. M. Guerrero, "Secondary control strategies for frequency restoration in islanded microgrids with consideration of communication delays," *IEEE Trans. Smart Grid*, vol. 7, no. 3, pp. 1430–1441, May 2016, doi: [10.1109/TSG.2015.2461190](https://doi.org/10.1109/TSG.2015.2461190).
- [51] G. Yao, Y. Lu, T. Tang, M. Benbouzid, Y. Zheng, and T. Wang, "A central control strategy of parallel inverters in AC microgrid," in *Proc. IECON 39th Annu. Conf. IEEE Ind. Electron. Soc.*, Nov. 2013, pp. 7112–7117, doi: [10.1109/IECON.2013.6700314](https://doi.org/10.1109/IECON.2013.6700314).
- [52] A. Bidram and A. Davoudi, "Hierarchical structure of microgrids control system," *IEEE Trans. Smart Grid*, vol. 3, no. 4, pp. 1963–1976, Dec. 2012, doi: [10.1109/TSG.2012.2197425](https://doi.org/10.1109/TSG.2012.2197425).
- [53] M. Helfert, "Secondary control in AC microgrids challenges and solutions," in *Proc. Int. Conf. Smart Cities Green ICT Syst. (SMART-GREENS)*, May 2015, pp. 1–6.
- [54] K. S. Rajesh, S. S. Dash, R. Rajagopal, and R. Sridhar, "A review on control of AC microgrid," *Renew. Sustain. Energy Rev.*, vol. 71, pp. 814–819, May 2017, doi: [10.1016/j.rser.2016.12.106](https://doi.org/10.1016/j.rser.2016.12.106).
- [55] T. Wu, J. Liu, Z. Liu, S. Wang, and B. Liu, "Load power estimation based secondary control for microgrids," in *Proc. 9th Int. Conf. Power Electron. ECCE Asia (ICPE-ECCE Asia)*, Jun. 2015, pp. 722–727, doi: [10.1109/ICPE.2015.7167863](https://doi.org/10.1109/ICPE.2015.7167863).
- [56] D.-L. Nguyen and H.-H. Lee, "A survey on cooperative control strategies for DC microgrids," *Neurocomputing*, vol. 486, pp. 225–236, May 2022, doi: [10.1016/j.neucom.2021.11.036](https://doi.org/10.1016/j.neucom.2021.11.036).
- [57] X. Lu, J. M. Guerrero, K. Sun, and J. C. Vasquez, "An improved droop control method for DC microgrids based on low bandwidth communication with DC bus voltage restoration and enhanced current sharing accuracy," *IEEE Trans. Power Electron.*, vol. 29, no. 4, pp. 1800–1812, Apr. 2014, doi: [10.1109/TPEL.2013.2266419](https://doi.org/10.1109/TPEL.2013.2266419).
- [58] D. Wu, T. Dragicevic, J. C. Vasquez, J. M. Guerrero, and Y. Guan, "Secondary coordinated control of islanded microgrids based on consensus algorithms," in *Proc. IEEE Energy Convers. Congr. Expo. (ECCE)*, Sep. 2014, pp. 4290–4297, doi: [10.1109/ECCE.2014.6953986](https://doi.org/10.1109/ECCE.2014.6953986).
- [59] P. Danzi, C. Stefanovic, L. Meng, J. M. Guerrero, and P. Popovski, "On the impact of wireless jamming on the distributed secondary microgrid control," in *Proc. IEEE Globecom Workshops (GC Wkshps)*, Dec. 2016, pp. 1–6, doi: [10.1109/GLOCOMW.2016.7848980](https://doi.org/10.1109/GLOCOMW.2016.7848980).
- [60] E. A. Coelho, D. Wu, J. M. Guerrero, J. C. Vasquez, T. Dragicevic, C. Stefanovic, and P. Popovski, "Small-signal analysis of the microgrid secondary control considering a communication time delay," *IEEE Trans. Ind. Electron.*, vol. 63, no. 10, pp. 6257–6269, Oct. 2016, doi: [10.1109/TIE.2016.2581155](https://doi.org/10.1109/TIE.2016.2581155).
- [61] *The 3rd IEEE International Power Electronics and Application Conference*. Accessed: Oct. 27, 2022. [Online]. Available: <http://www.peac-conf.org/>
- [62] Q. Shafiee, C. Stefanovic, T. Dragicevic, P. Popovski, J. C. Vasquez, and J. M. Guerrero, "Robust networked control scheme for distributed secondary control of islanded microgrids," *IEEE Trans. Ind. Electron.*, vol. 61, no. 10, pp. 5363–5374, Oct. 2014, doi: [10.1109/TIE.2013.2293711](https://doi.org/10.1109/TIE.2013.2293711).
- [63] A. Kahrobaian and Y. A. I. Mohamed, "Networked-based hybrid distributed power sharing and control for islanded microgrid systems," *IEEE Trans. Power Electron.*, vol. 30, no. 2, pp. 603–617, Feb. 2015, doi: [10.1109/TPEL.2014.2312425](https://doi.org/10.1109/TPEL.2014.2312425).
- [64] M. S. Mahmoud and S. A. Hussain, "Adaptive PI secondary control for smart autonomous microgrid systems," *Int. J. Adapt. Control Signal Process.*, vol. 29, no. 11, pp. 1442–1458, Nov. 2015, doi: [10.1002/ACS.2559](https://doi.org/10.1002/ACS.2559).
- [65] J. W. Simpson-Porco, F. Dorfler, F. Bullo, Q. Shafiee, and J. M. Guerrero, "Stability, power sharing, & distributed secondary control in droop-controlled microgrids," in *Proc. IEEE Int. Conf. Smart Grid Commun. (SmartGridComm)*, Oct. 2013, pp. 672–677, doi: [10.1109/SMART-GRIDCOMM.2013.6688036](https://doi.org/10.1109/SMART-GRIDCOMM.2013.6688036).
- [66] A. Bidram, A. Davoudi, F. L. Lewis, and J. M. Guerrero, "Distributed cooperative secondary control of microgrids using feedback linearization," *IEEE Trans. Power Syst.*, vol. 28, no. 3, pp. 3462–3470, Aug. 2013, doi: [10.1109/TPWRS.2013.2247071](https://doi.org/10.1109/TPWRS.2013.2247071).
- [67] Z. Wang, H. Sun, and D. Nikovski, "Distributed secondary voltage controller for droop-controlled microgrids to improve power quality in power distribution networks," in *Proc. IEEE Power Energy Soc. Gen. Meeting (PESGM)*, Jul. 2016, pp. 1–5, doi: [10.1109/PESGM.2016.7741071](https://doi.org/10.1109/PESGM.2016.7741071).
- [68] Z. Yu, Q. Ai, J. Gong, and L. Piao, "A novel secondary control for microgrid based on synergetic control of multi-agent system," *Energies*, vol. 9, no. 4, p. 243, Mar. 2016, doi: [10.3390/EN9040243](https://doi.org/10.3390/EN9040243).
- [69] F. Guo, Q. Xu, C. Wen, L. Wang, and P. Wang, "Distributed secondary control for power allocation and voltage restoration in islanded DC microgrids," *IEEE Trans. Sustain. Energy*, vol. 9, no. 4, pp. 1857–1869, Oct. 2018, doi: [10.1109/TSTE.2018.2816944](https://doi.org/10.1109/TSTE.2018.2816944).
- [70] X. Lu, X. Yu, J. Lai, J. M. Guerrero, and H. Zhou, "Distributed secondary voltage and frequency control for islanded microgrids with uncertain communication links," *IEEE Trans. Ind. Informat.*, vol. 13, no. 2, pp. 448–460, Apr. 2017, doi: [10.1109/TII.2016.2603844](https://doi.org/10.1109/TII.2016.2603844).
- [71] N. M. Dehkordi, N. Sadati, and M. Hamzeh, "Distributed robust finite-time secondary voltage and frequency control of islanded microgrids," *IEEE Trans. Power Syst.*, vol. 32, no. 5, pp. 3648–3659, Sep. 2017, doi: [10.1109/TPWRS.2016.2634085](https://doi.org/10.1109/TPWRS.2016.2634085).
- [72] M. Chen, X. Xiao, and J. M. Guerrero, "Secondary restoration control of islanded microgrids with a decentralized event-triggered strategy," *IEEE Trans. Ind. Informat.*, vol. 14, no. 9, pp. 3870–3880, Sep. 2018, doi: [10.1109/TII.2017.2784561](https://doi.org/10.1109/TII.2017.2784561).
- [73] N. M. Dehkordi, N. Sadati, and M. Hamzeh, "Fully distributed cooperative secondary frequency and voltage control of islanded microgrids," *IEEE Trans. Energy Convers.*, vol. 32, no. 2, pp. 675–685, Jun. 2017, doi: [10.1109/TEC.2016.2638858](https://doi.org/10.1109/TEC.2016.2638858).
- [74] A. Asheibi, A. Khalil, A. M. Elbreki, Z. Rajab, A. Alfergani, A. Mohamed, and A. Nouh, "Stability analysis of PV-based DC microgrid with communication delay," in *Proc. 9th Int. Renew. Energy Congr. (IREC)*, Mar. 2018, pp. 1–6, doi: [10.1109/IREC.2018.8362556](https://doi.org/10.1109/IREC.2018.8362556).
- [75] S. Anand, B. G. Fernandes, and J. Guerrero, "Distributed control to ensure proportional load sharing and improve voltage regulation in low-voltage DC microgrids," *IEEE Trans. Power Electron.*, vol. 28, no. 4, pp. 1900–1913, Apr. 2013, doi: [10.1109/TPEL.2012.2215055](https://doi.org/10.1109/TPEL.2012.2215055).
- [76] F. Guo, L. Wang, C. Wen, D. Zhang, and Q. Xu, "Distributed voltage restoration and current sharing control in islanded DC microgrid systems without continuous communication," *IEEE Trans. Ind. Electron.*, vol. 67, no. 4, pp. 3043–3053, Apr. 2020, doi: [10.1109/TIE.2019.2907507](https://doi.org/10.1109/TIE.2019.2907507).
- [77] B. Fan, J. Peng, J. Duan, Q. Yang, and W. Liu, "Distributed control of multiple-bus microgrid with paralleled distributed generators," *IEEE/CAA J. Autom. Sinica*, vol. 6, no. 3, pp. 676–684, May 2019, doi: [10.1109/JAS.2019.1911477](https://doi.org/10.1109/JAS.2019.1911477).
- [78] F. Gao, S. Bozhko, G. Asher, P. Wheeler, and C. Patel, "An improved voltage compensation approach in a droop-controlled DC power system for the more electric aircraft," *IEEE Trans. Power Electron.*, vol. 31, no. 10, pp. 7369–7383, Oct. 2016, doi: [10.1109/TPEL.2015.2510285](https://doi.org/10.1109/TPEL.2015.2510285).
- [79] M. Mehdi, C.-H. Kim, and M. Saad, "Robust centralized control for DC islanded microgrid considering communication network delay," *IEEE Access*, vol. 8, pp. 77765–77778, 2020, doi: [10.1109/ACCESS.2020.2989777](https://doi.org/10.1109/ACCESS.2020.2989777).
- [80] K. R. Bharath, H. Choutapalli, and P. Kanakasabapathy, "Control of bidirectional DC–DC converter in renewable based DC microgrid with improved voltage stability," *Int. J. Renew. Energy Res.*, vol. 8, no. 2, pp. 871–877, 2018, doi: [10.20508/ijrer.v8i2.7509.g7374](https://doi.org/10.20508/ijrer.v8i2.7509.g7374).
- [81] E. Rokrok and M. E. Golshan, "Adaptive voltage droop scheme for voltage source converters in an islanded multibus microgrid," *IET Gener., Transmiss. Distrib.*, vol. 4, no. 5, pp. 562–578, May 2010, doi: [10.1049/IET-GTD.2009.014](https://doi.org/10.1049/IET-GTD.2009.014).
- [82] A. H. Hajimiragha and M. R. D. Zadeh, "Research and development of a microgrid control and monitoring system for the remote community of Bella Coola: Challenges, solutions, achievements and lessons learned," in *Proc. IEEE Int. Conf. Smart Energy Grid Eng. (SEGE)*, Aug. 2013, pp. 1–6, doi: [10.1109/SEGE.2013.6707898](https://doi.org/10.1109/SEGE.2013.6707898).
- [83] F. Mohammadi, G.-A. Nazri, and M. Saif, "A bidirectional power charging control strategy for plug-in hybrid electric vehicles," *Sustainability*, vol. 11, no. 16, p. 4317, Aug. 2019, doi: [10.3390/SU11164317](https://doi.org/10.3390/SU11164317).
- [84] F. Guo, C. Wen, J. Mao, J. Chen, and Y.-D. Song, "Distributed cooperative secondary control for voltage unbalance compensation in an islanded microgrid," *IEEE Trans. Ind. Informat.*, vol. 11, no. 5, pp. 1078–1088, Oct. 2015, doi: [10.1109/TII.2015.2462773](https://doi.org/10.1109/TII.2015.2462773).

- [85] R. A. F. Ferreira, H. A. C. Braga, A. A. Ferreira, and P. G. Barbosa, "Analysis of voltage droop control method for DC microgrids with simulink: Modelling and simulation," in *Proc. 10th IEEE/IAS Int. Conf. Ind. Appl.*, Nov. 2012, pp. 1–6, doi: [10.1109/INDUSCON.2012.6452563](https://doi.org/10.1109/INDUSCON.2012.6452563).
- [86] S. Gholami, S. Saha, and M. Aldeen, "Robust multiobjective control method for power sharing among distributed energy resources in islanded microgrids with unbalanced and nonlinear loads," *Int. J. Electr. Power Energy Syst.*, vol. 94, pp. 321–338, Jan. 2018, doi: [10.1016/j.ijepes.2017.07.012](https://doi.org/10.1016/j.ijepes.2017.07.012).
- [87] C. Deng, W.-W. Che, and Z.-G. Wu, "A dynamic periodic event-triggered approach to consensus of heterogeneous linear multiagent systems with time-varying communication delays," *IEEE Trans. Cybern.*, vol. 51, no. 4, pp. 1812–1821, Apr. 2021, doi: [10.1109/TCYB.2020.3015746](https://doi.org/10.1109/TCYB.2020.3015746).
- [88] F. L. Lewis, H. Zhang, K. Hengster-Movric, and A. Das, *Cooperative Control of Multi-Agent Systems* (Communications and Control Engineering). London, U.K.: Springer, 2014, doi: [10.1007/978-1-4471-5574-4](https://doi.org/10.1007/978-1-4471-5574-4).
- [89] R. Yang, L. Liu, and G. Feng, "An overview of recent advances in distributed coordination of multi-agent systems," *Unmanned Syst.*, vol. 10, no. 3, pp. 307–325, Jul. 2022, doi: [10.1142/S2301385021500199](https://doi.org/10.1142/S2301385021500199).
- [90] A. Bidram, V. Nasirian, A. Davoudi, and F. L. Lewis, *Cooperative Synchronization in Distributed Microgrid Control*. Cham, Switzerland: Springer, 2017, doi: [10.1007/978-3-319-50808-5](https://doi.org/10.1007/978-3-319-50808-5).
- [91] K. E. Antoniadou-Plytaria, I. N. Kouveliotis-Lysikatos, P. S. Georgilakis, and N. D. Hatzizargyriou, "Distributed and decentralized voltage control of smart distribution networks: Models, methods, and future research," *IEEE Trans. Smart Grid*, vol. 8, no. 6, pp. 2999–3008, Nov. 2017, doi: [10.1109/TSG.2017.2679238](https://doi.org/10.1109/TSG.2017.2679238).
- [92] U. Münz, A. Papachristodoulou, and F. Allgöwer, "Delay robustness in consensus problems," *Automatica*, vol. 46, no. 8, pp. 1252–1265, Aug. 2010, doi: [10.1016/j.automatica.2010.04.008](https://doi.org/10.1016/j.automatica.2010.04.008).
- [93] C. Nowzari, E. Garcia, and J. Cortés, "Event-triggered communication and control of networked systems for multi-agent consensus," *Automatica*, vol. 105, pp. 1–27, Jul. 2019, doi: [10.1016/j.automatica.2019.03.009](https://doi.org/10.1016/j.automatica.2019.03.009).
- [94] J. Qin, W. X. Zheng, and H. Gao, "Convergence analysis for multiple agents with double-integrator dynamics in a sampled-data setting," *IET Control Theory Appl.*, vol. 5, no. 18, pp. 2089–2097, Dec. 2011, doi: [10.1049/IET-CTA.2010.0397](https://doi.org/10.1049/IET-CTA.2010.0397).
- [95] J. Qin, W. X. Zheng, and H. Gao, "Coordination of multiple agents with double-integrator dynamics under generalized interaction topologies," *IEEE Trans. Syst. Man, Cybern. B, Cybern.*, vol. 42, no. 1, pp. 44–57, Feb. 2012, doi: [10.1109/TSMCB.2011.2164523](https://doi.org/10.1109/TSMCB.2011.2164523).
- [96] W. Yu, P. DeLellis, G. Chen, M. di Bernardo, and J. Kurths, "Distributed adaptive control of synchronization in complex networks," *IEEE Trans. Autom. Control*, vol. 57, no. 8, pp. 2153–2158, Aug. 2012, doi: [10.1109/TAC.2012.2183190](https://doi.org/10.1109/TAC.2012.2183190).
- [97] Z. Li, W. Ren, X. Liu, and L. Xie, "Distributed consensus of linear multi-agent systems with adaptive dynamic protocols," *Automatica*, vol. 49, no. 7, pp. 1986–1995, Jul. 2013, doi: [10.1016/j.automatica.2013.03.015](https://doi.org/10.1016/j.automatica.2013.03.015).
- [98] A. Nedic, A. Ozdaglar, and P. A. Parrilo, "Constrained consensus and optimization in multi-agent networks," *IEEE Trans. Autom. Control*, vol. 55, no. 4, pp. 922–938, Apr. 2010, doi: [10.1109/TAC.2010.2041686](https://doi.org/10.1109/TAC.2010.2041686).
- [99] P. Lin and W. Ren, "Constrained consensus in unbalanced networks with communication delays," *IEEE Trans. Autom. Control*, vol. 59, no. 3, pp. 775–781, Mar. 2014, doi: [10.1109/TAC.2013.2275671](https://doi.org/10.1109/TAC.2013.2275671).
- [100] *Converse Theorems for Finite Time Stability on JSTOR*. Accessed: Oct. 27, 2022. [Online]. Available: <https://www.jstor.org/stable/2099547>
- [101] L. Wang and F. Xiao, "Finite-time consensus problems for networks of dynamic agents," *IEEE Trans. Autom. Control*, vol. 55, no. 4, pp. 950–955, Apr. 2010, doi: [10.1109/TAC.2010.2041610](https://doi.org/10.1109/TAC.2010.2041610).
- [102] D. Spanos, R. Olfati-Saber, and R. Murray, "Dynamic consensus on mobile networks," in *Proc. 16th IFAC World Congr.*, 2005, pp. 1–6. [Online]. Available: <http://www.nt.ntnu.no/users/skoge/prost/proceedings/ifac2005/Fullpapers/04505.pdf>
- [103] Z. Li, Z. Duan, G. Chen, and L. Huang, "Consensus of multiagent systems and synchronization of complex networks: A unified viewpoint," *IEEE Trans. Circuits Syst. I, Reg. Papers*, vol. 57, no. 1, pp. 213–224, Jan. 2010, doi: [10.1109/TCSI.2009.2023937](https://doi.org/10.1109/TCSI.2009.2023937).
- [104] C.-J. Ong and B. Hou, "Consensus of heterogeneous multi-agent system with input constraints," *Automatica*, vol. 134, Dec. 2021, Art. no. 109895, doi: [10.1016/j.automatica.2021.109895](https://doi.org/10.1016/j.automatica.2021.109895).
- [105] J. M. Kim, J. B. Park, and Y. H. Choi, "Leaderless and leader-following consensus for heterogeneous multi-agent systems with random link failures," *IET Control Theory Appl.*, vol. 8, no. 1, pp. 51–60, Jan. 2014, doi: [10.1049/IET-CTA.2012.0855](https://doi.org/10.1049/IET-CTA.2012.0855).
- [106] Q. Hui, W. M. Haddad, and S. P. Bhat, "On robust control algorithms for nonlinear network consensus protocols," *Int. J. Robust Nonlinear Control*, vol. 20, no. 3, pp. 269–284, Feb. 2010, doi: [10.1002/RNC.1426](https://doi.org/10.1002/RNC.1426).
- [107] D. V. Dimarogonas, E. Frazzoli, and K. H. Johansson, "Distributed event-triggered control for multi-agent systems," *IEEE Trans. Autom. Control*, vol. 57, no. 5, pp. 1291–1297, May 2012, doi: [10.1109/TAC.2011.2174666](https://doi.org/10.1109/TAC.2011.2174666).
- [108] X. Ge and Q.-L. Han, "Distributed formation control of networked multi-agent systems using a dynamic event-triggered communication mechanism," *IEEE Trans. Ind. Electron.*, vol. 64, no. 10, pp. 8118–8127, Oct. 2017, doi: [10.1109/TIE.2017.2701778](https://doi.org/10.1109/TIE.2017.2701778).
- [109] X. Yin, D. Yue, S. Hu, C. Peng, and Y. Xue, "Model-based event-triggered predictive control for networked systems with data dropout," *SIAM J. Control Optim.*, vol. 54, no. 2, pp. 567–586, Mar. 2016, doi: [10.1137/130950951](https://doi.org/10.1137/130950951).
- [110] X. Zhang and Q. Han, "Event-triggered dynamic output feedback control for networked control systems," *IET Control Theory Appl.*, vol. 8, no. 4, pp. 226–234, Mar. 2014, doi: [10.1049/IET-CTA.2013.0253](https://doi.org/10.1049/IET-CTA.2013.0253).
- [111] W. P. M. H. Heemels, K. H. Johansson, and P. Tabuada, "An introduction to event-triggered and self-triggered control," in *Proc. IEEE 51st IEEE Conf. Decis. Control (CDC)*, Dec. 2012, pp. 3270–3285, doi: [10.1109/CDC.2012.6425820](https://doi.org/10.1109/CDC.2012.6425820).
- [112] L. Xing, Q. Xu, F. Guo, Z.-G. Wu, and M. Liu, "Distributed secondary control for DC microgrid with event-triggered signal transmissions," *IEEE Trans. Sustain. Energy*, vol. 12, no. 3, pp. 1801–1810, Jul. 2021, doi: [10.1109/TSTE.2021.3066334](https://doi.org/10.1109/TSTE.2021.3066334).
- [113] J. Zhou, Y. Xu, H. Sun, L. Wang, and M.-Y. Chow, "Distributed event-triggered H_∞ consensus based current sharing control of DC microgrids considering uncertainties," *IEEE Trans. Ind. Informat.*, vol. 16, no. 12, pp. 7413–7425, Dec. 2020, doi: [10.1109/TII.2019.2961151](https://doi.org/10.1109/TII.2019.2961151).
- [114] P. Wang, R. Huang, M. Zaery, W. Wang, and D. Xu, "A fully distributed fixed-time secondary controller for DC microgrids," *IEEE Trans. Ind. Appl.*, vol. 56, no. 6, pp. 6586–6597, Nov. 2020, doi: [10.1109/TIA.2020.3016284](https://doi.org/10.1109/TIA.2020.3016284).
- [115] E. Garcia, Y. Cao, and D. W. Casbeer, "Decentralized event-triggered consensus with general linear dynamics," *Automatica*, vol. 50, no. 10, pp. 2633–2640, Oct. 2014, doi: [10.1016/j.automatica.2014.08.024](https://doi.org/10.1016/j.automatica.2014.08.024).
- [116] D. Yang, W. Ren, X. Liu, and W. Chen, "Decentralized event-triggered consensus for linear multi-agent systems under general directed graphs," *Automatica*, vol. 69, pp. 242–249, Jul. 2016, doi: [10.1016/j.automatica.2016.03.003](https://doi.org/10.1016/j.automatica.2016.03.003).
- [117] H. Zhang, G. Feng, H. Yan, and Q. Chen, "Observer-based output feedback event-triggered control for consensus of multi-agent systems," *IEEE Trans. Ind. Electron.*, vol. 61, no. 9, pp. 4885–4894, Sep. 2014, doi: [10.1109/TIE.2013.2290757](https://doi.org/10.1109/TIE.2013.2290757).
- [118] Z. Zhang, L. Zhang, F. Hao, and L. Wang, "Leader-following consensus for linear and Lipschitz nonlinear multiagent systems with quantized communication," *IEEE Trans. Cybern.*, vol. 47, no. 8, pp. 1970–1982, Aug. 2017, doi: [10.1109/TCYB.2016.2580163](https://doi.org/10.1109/TCYB.2016.2580163).
- [119] A. Adaldo, F. Alderisio, D. Liuzza, G. Shi, D. V. Dimarogonas, M. di Bernardo, and K. H. Johansson, "Event-triggered pinning control of switching networks," *IEEE Trans. Control Netw. Syst.*, vol. 2, no. 2, pp. 204–213, Jun. 2015, doi: [10.1109/TCNS.2015.2428531](https://doi.org/10.1109/TCNS.2015.2428531).
- [120] D. Liuzza, D. V. Dimarogonas, M. di Bernardo, and K. H. Johansson, "Distributed model based event-triggered control for synchronization of multi-agent systems," *Automatica*, vol. 73, pp. 1–7, Nov. 2016, doi: [10.1016/j.automatica.2016.06.011](https://doi.org/10.1016/j.automatica.2016.06.011).
- [121] Z. Zhang, F. Hao, L. Zhang, and L. Wang, "Consensus of linear multi-agent systems via event-triggered control," *Int. J. Control*, vol. 87, no. 6, pp. 1243–1251, Jun. 2014, doi: [10.1080/00207179.2013.873952](https://doi.org/10.1080/00207179.2013.873952).
- [122] C. Nowzari and J. Cortés, "Distributed event-triggered coordination for average consensus on weight-balanced digraphs," *Automatica*, vol. 68, pp. 237–244, Jun. 2016, doi: [10.1016/j.automatica.2016.01.069](https://doi.org/10.1016/j.automatica.2016.01.069).
- [123] E. Garcia, Y. Cao, H. Yu, P. Antsaklis, and D. Casbeer, "Decentralised event-triggered cooperative control with limited communication," *Int. J. Control*, vol. 86, no. 9, pp. 1479–1488, Sep. 2013, doi: [10.1080/00207179.2013.787647](https://doi.org/10.1080/00207179.2013.787647).

- [124] S. S. Kia, J. Cortés, and S. Martínez, "Distributed event-triggered communication for dynamic average consensus in networked systems," *Automatica*, vol. 59, pp. 112–119, Sep. 2015, doi: [10.1016/J.AUTOMATICA.2015.06.011](https://doi.org/10.1016/J.AUTOMATICA.2015.06.011).
- [125] H. Yu and P. J. Antsaklis, "Output synchronization of networked passive systems with event-driven communication," *IEEE Trans. Autom. Control*, vol. 59, no. 3, pp. 750–756, Mar. 2014, doi: [10.1109/TAC.2013.2274704](https://doi.org/10.1109/TAC.2013.2274704).
- [126] X. Yin, D. Yue, and S. Hu, "Adaptive periodic event-triggered consensus for multi-agent systems subject to input saturation," *Int. J. Control*, vol. 89, no. 4, pp. 653–667, Apr. 2016, doi: [10.1080/00207179.2015.1088967](https://doi.org/10.1080/00207179.2015.1088967).
- [127] G. S. Seyboth, D. V. Dimarogonas, and K. H. Johansson, "Event-based broadcasting for multi-agent average consensus," *Automatica*, vol. 49, no. 1, pp. 245–252, Jan. 2013, doi: [10.1016/J.AUTOMATICA.2012.08.042](https://doi.org/10.1016/J.AUTOMATICA.2012.08.042).
- [128] L. Xing, C. Wen, F. Guo, Z. Liu, and H. Su, "Event-based consensus for linear multiagent systems without continuous communication," *IEEE Trans. Cybern.*, vol. 47, no. 8, pp. 2132–2142, Aug. 2017, doi: [10.1109/TCYB.2016.2610419](https://doi.org/10.1109/TCYB.2016.2610419).
- [129] Y. Fan, G. Feng, Y. Wang, and C. Song, "Distributed event-triggered control of multi-agent systems with combinational measurements," *Automatica*, vol. 49, no. 2, pp. 671–675, Feb. 2013, doi: [10.1016/J.AUTOMATICA.2012.11.010](https://doi.org/10.1016/J.AUTOMATICA.2012.11.010).
- [130] W. Zhu, Z.-P. Jiang, and G. Feng, "Event-based consensus of multi-agent systems with general linear models," *Automatica*, vol. 50, no. 2, pp. 552–558, Feb. 2014, doi: [10.1016/J.AUTOMATICA.2013.11.023](https://doi.org/10.1016/J.AUTOMATICA.2013.11.023).
- [131] H. Li, X. Liao, T. Huang, and W. Zhu, "Event-triggering sampling based leader-following consensus in second-order multi-agent systems," *IEEE Trans. Autom. Control*, vol. 60, no. 7, pp. 1998–2003, Jul. 2015, doi: [10.1109/TAC.2014.2365073](https://doi.org/10.1109/TAC.2014.2365073).
- [132] Y. Cheng and V. Ugrinovskii, "Event-triggered leader-following tracking control for multivariable multi-agent systems," *Automatica*, vol. 70, pp. 204–210, Aug. 2016, doi: [10.1016/J.AUTOMATICA.2016.04.003](https://doi.org/10.1016/J.AUTOMATICA.2016.04.003).
- [133] W. Zhu and Z.-P. Jiang, "Event-based leader-following consensus of multi-agent systems with input time delay," *IEEE Trans. Autom. Control*, vol. 60, no. 5, pp. 1362–1367, May 2015, doi: [10.1109/TAC.2014.2357131](https://doi.org/10.1109/TAC.2014.2357131).
- [134] W. Hu, L. Liu, and G. Feng, "Output consensus of heterogeneous linear multi-agent systems by distributed event-triggered/self-triggered strategy," *IEEE Trans. Cybern.*, vol. 47, no. 8, pp. 1914–1924, Aug. 2017, doi: [10.1109/TCYB.2016.2602327](https://doi.org/10.1109/TCYB.2016.2602327).
- [135] Y. Zhao, L. Ding, G. Guo, and G. Yang, "Event-triggered average consensus for mobile sensor networks under a given energy budget," *J. Franklin Inst.*, vol. 352, no. 12, pp. 5646–5660, Dec. 2015, doi: [10.1016/J.JFRANKLIN.2015.09.014](https://doi.org/10.1016/J.JFRANKLIN.2015.09.014).
- [136] X. Meng and T. Chen, "Event based agreement protocols for multi-agent networks," *Automatica*, vol. 49, no. 7, pp. 2125–2132, Jul. 2013, doi: [10.1016/J.AUTOMATICA.2013.03.002](https://doi.org/10.1016/J.AUTOMATICA.2013.03.002).
- [137] F. Xiao, X. Meng, and T. Chen, "Sampled-data consensus in switching networks of integrators based on edge events," *Int. J. Control*, vol. 88, no. 2, pp. 391–402, Feb. 2015, doi: [10.1080/00207179.2014.955530](https://doi.org/10.1080/00207179.2014.955530).
- [138] E. Garcia, Y. Cao, and D. W. Casbeer, "Periodic event-triggered synchronization of linear multi-agent systems with communication delays," *IEEE Trans. Autom. Control*, vol. 62, no. 1, pp. 366–371, Jan. 2017, doi: [10.1109/TAC.2016.2555484](https://doi.org/10.1109/TAC.2016.2555484).
- [139] Y. Fan, L. Liu, G. Feng, and Y. Wang, "Self-triggered consensus for multi-agent systems with zero-free triggers," *IEEE Trans. Autom. Control*, vol. 60, no. 10, pp. 2779–2784, Oct. 2015, doi: [10.1109/TAC.2015.2405294](https://doi.org/10.1109/TAC.2015.2405294).
- [140] C. De Persis and P. Frasca, "Robust self-triggered coordination with ternary controllers," *IEEE Trans. Autom. Control*, vol. 58, no. 12, pp. 3024–3038, Dec. 2013, doi: [10.1109/TAC.2013.2273302](https://doi.org/10.1109/TAC.2013.2273302).
- [141] C. Nowzari and J. Cortés, "Team-triggered coordination for real-time control of networked cyber-physical systems," *IEEE Trans. Autom. Control*, vol. 61, no. 1, pp. 34–47, Jan. 2016, doi: [10.1109/TAC.2015.2422491](https://doi.org/10.1109/TAC.2015.2422491).
- [142] G. Lou, W. Gu, J. Wang, W. Sheng, and L. Sun, "Optimal design for distributed secondary voltage control in islanded microgrids: Communication topology and controller," *IEEE Trans. Power Syst.*, vol. 34, no. 2, pp. 968–981, Mar. 2019, doi: [10.1109/TPWRS.2018.2870058](https://doi.org/10.1109/TPWRS.2018.2870058).
- [143] Y. Mohamed and E. F. El-Saadany, "Adaptive decentralized droop controller to preserve power sharing stability of paralleled inverters in distributed generation microgrids," *IEEE Trans. Power Electron.*, vol. 23, no. 6, pp. 2806–2816, Nov. 2008, doi: [10.1109/TPEL.2008.2005100](https://doi.org/10.1109/TPEL.2008.2005100).
- [144] X. Lu and J. Lai, "Communication constraints for distributed secondary control of heterogeneous microgrids: A survey," *IEEE Trans. Ind. Appl.*, vol. 57, no. 6, pp. 5636–5648, Nov. 2021, doi: [10.1109/TIA.2021.3104792](https://doi.org/10.1109/TIA.2021.3104792).
- [145] Z. Zhang, C. Dou, D. Yue, B. Zhang, S. Xu, T. Hayat, and A. Alsaedi, "An event-triggered secondary control strategy with network delay in islanded microgrids," *IEEE Syst. J.*, vol. 13, no. 2, pp. 1851–1860, Jun. 2019, doi: [10.1109/JSYST.2018.2832065](https://doi.org/10.1109/JSYST.2018.2832065).
- [146] I. Ali and S. M. S. Hussain, "Communication design for energy management automation in microgrid," *IEEE Trans. Smart Grid*, vol. 9, no. 3, pp. 2055–2064, May 2018, doi: [10.1109/TSG.2016.2606131](https://doi.org/10.1109/TSG.2016.2606131).
- [147] E. Hossain, E. Kabalci, R. Bayindir, and R. Perez, "A comprehensive study on microgrid technology," *Int. J. Renew. Energy Res.*, vol. 4, no. 4, pp. 1094–1104, 2014.
- [148] M. Yadav, N. Pal, and D. K. Saini, "Microgrid control, storage, and communication strategies to enhance resiliency for survival of critical load," *IEEE Access*, vol. 8, pp. 169047–169069, 2020, doi: [10.1109/ACCESS.2020.3023087](https://doi.org/10.1109/ACCESS.2020.3023087).
- [149] S. G. Gabert, J. C. Kaiser, D. J. Snyder, P. Ranganathan, and R. Fazel-Rezai, "Data acquisition and control of microgrid using ZigBee—A senior design project," in *Proc. North Midwest Sect. Meeting, ASEE-NMWS*, 2021, pp. 97–109.
- [150] S. Ghosh, C. K. Chanda, and J. K. Das, "A comprehensive survey on communication technologies for a grid connected microgrid system," in *Proc. Int. Conf. Artif. Intell. Smart Syst. (ICAIS)*, Mar. 2021, pp. 1525–1528, doi: [10.1109/ICAIS50930.2021.9395820](https://doi.org/10.1109/ICAIS50930.2021.9395820).
- [151] H. Yan, J. Han, H. Zhang, X. Zhan, and Y. Wang, "Adaptive event-triggered predictive control for finite time microgrid," *IEEE Trans. Circuits Syst. I, Reg. Papers*, vol. 67, no. 3, pp. 1035–1044, Mar. 2020, doi: [10.1109/TCSI.2019.2953958](https://doi.org/10.1109/TCSI.2019.2953958).
- [152] (4) (PDF) *Robust H_∞ Control of Networked System in Microgrid Under Random Packet Loss*. Accessed: Oct. 27, 2022. [Online]. Available: https://www.researchgate.net/publication/352069644_Robust_H_Control_of_Networked_System_In_Microgrid_Under_Random_Packet_Loss
- [153] N. M. Dehkordi, A. Khorsandi, H. R. Baghaee, N. Sadati, S. S. Moggaddam, and J. M. Guerrero, "Voltage and frequency consensusability of autonomous microgrids over fading channels," *IEEE Trans. Energy Convers.*, vol. 36, no. 1, pp. 149–158, Mar. 2021, doi: [10.1109/TEC.2020.3005269](https://doi.org/10.1109/TEC.2020.3005269).
- [154] D. Nojavanzadeh, S. Lottifard, Z. Liu, A. Saberi, and A. A. Stoorvogel, "Scale-free cooperative control of inverter-based microgrids with general time-varying communication graphs," *IEEE Trans. Power Syst.*, vol. 37, no. 3, pp. 2197–2207, May 2022, doi: [10.1109/TPWRS.2021.3118993](https://doi.org/10.1109/TPWRS.2021.3118993).
- [155] D. Jin, Z. Li, C. Hannon, C. Chen, J. Wang, M. Shahidehpour, and C. W. Lee, "Toward a cyber resilient and secure microgrid using software-defined networking," *IEEE Trans. Smart Grid*, vol. 8, no. 5, pp. 2494–2504, Sep. 2017, doi: [10.1109/TSG.2017.2703911](https://doi.org/10.1109/TSG.2017.2703911).
- [156] C. Dou, B. Zhang, D. Yue, and Z. Zhang, "Cyber-physical cooperative control strategy for islanded micro-grid considering communication interruption," *Int. Trans. Electr. Energy Syst.*, vol. 29, no. 1, Jan. 2019, Art. no. e2695, doi: [10.1002/ETEP.2695](https://doi.org/10.1002/ETEP.2695).
- [157] R. E. Perez-Guzman, Y. Salgueiro, M. Rivera, J. Munoz, and S. Toledo, "Modelling communication network for intelligent applications in microgrids—Part II," in *Proc. IEEE Int. Conf. Automat./23rd Congr. Chilean Assoc. Autom. Control (ICA-ACCA)*, Oct. 2018, pp. 1–6, doi: [10.1109/ICA-ACCA.2018.8609780](https://doi.org/10.1109/ICA-ACCA.2018.8609780).
- [158] F. Aghaee, M. Dehkordi, N. Bayati, and A. Hajizadeh, "Distributed control methods and impact of communication failure in AC microgrids: A comparative review," *Electronics*, vol. 8, no. 11, p. 1265, Nov. 2019, doi: [10.3390/ELECTRONICS8111265](https://doi.org/10.3390/ELECTRONICS8111265).
- [159] D. Wang, Z. Wang, M. Chen, and W. Wang, "Distributed optimization for multi-agent systems with constraints set and communication time-delay over a directed graph," *Inf. Sci.*, vol. 438, pp. 1–14, Apr. 2018, doi: [10.1016/J.INS.2018.01.040](https://doi.org/10.1016/J.INS.2018.01.040).
- [160] C. Dong, F. Guo, H. Jia, Y. Xu, X. Li, and P. Wang, "DC microgrid stability analysis considering time delay in the distributed control," *Energy Proc.*, vol. 142, pp. 2126–2131, Dec. 2017, doi: [10.1016/J.EGYPRO.2017.12.616](https://doi.org/10.1016/J.EGYPRO.2017.12.616).
- [161] A. F. Khalil and J. Wang, "A new stability and time-delay tolerance analysis approach for networked control systems," in *Proc. 49th IEEE Conf. Decis. Control (CDC)*, Dec. 2010, pp. 4753–4758, doi: [10.1109/CDC.2010.5718003](https://doi.org/10.1109/CDC.2010.5718003).

- [162] C. Dou, D. Yue, J. M. Guerrero, X. Xie, and S. Hu, "Multiagent system-based distributed coordinated control for radial DC microgrid considering transmission time delays," *IEEE Trans. Smart Grid*, vol. 8, no. 5, pp. 2370–2381, Sep. 2017, doi: [10.1109/TSG.2016.2524688](https://doi.org/10.1109/TSG.2016.2524688).
- [163] M. Dong, L. Li, Y. Nie, D. Song, and J. Yang, "Stability analysis of a novel distributed secondary control considering communication delay in DC microgrids," *IEEE Trans. Smart Grid*, vol. 10, no. 6, pp. 6690–6700, Nov. 2019, doi: [10.1109/TSG.2019.2910190](https://doi.org/10.1109/TSG.2019.2910190).
- [164] Z. Wang, W. Wu, and B. Zhang, "A distributed control method with minimum generation cost for DC microgrids," *IEEE Trans. Energy Convers.*, vol. 31, no. 4, pp. 1462–1470, Dec. 2016, doi: [10.1109/TEC.2016.2584649](https://doi.org/10.1109/TEC.2016.2584649).
- [165] X. Chen, M. Shi, H. Sun, Y. Li, and H. He, "Distributed cooperative control and stability analysis of multiple DC electric springs in a DC microgrid," *IEEE Trans. Ind. Electron.*, vol. 65, no. 7, pp. 5611–5622, Jul. 2018, doi: [10.1109/TIE.2017.2779414](https://doi.org/10.1109/TIE.2017.2779414).
- [166] Y. Hu, X. Wang, Y. Peng, J. Xiang, and W. Wei, "Distributed finite-time secondary control for DC microgrids with virtual impedance arrangement," *IEEE Access*, vol. 7, pp. 57060–57068, 2019, doi: [10.1109/ACCESS.2019.2914156](https://doi.org/10.1109/ACCESS.2019.2914156).
- [167] C. Dou, B. Zhang, D. Yue, Z. Zhang, S. Xu, T. Hayat, and A. Alsaedi, "A novel hierarchical control strategy combined with sliding mode control and consensus control for islanded micro-grid," *IET Renew. Power Gener.*, vol. 12, no. 9, pp. 1012–1024, Jul. 2018, doi: [10.1049/IET-RPG.2017.0754](https://doi.org/10.1049/IET-RPG.2017.0754).
- [168] S. Shrivastava, B. Subudhi, and S. Das, "Noise-resilient voltage and frequency synchronisation of an autonomous microgrid," *IET Gener., Transmiss. Distrib.*, vol. 13, no. 2, pp. 189–200, Jan. 2019, doi: [10.1049/IET-GTD.2018.6409](https://doi.org/10.1049/IET-GTD.2018.6409).
- [169] N. M. Dehkordi, H. R. Baghaee, N. Sadati, and J. M. Guerrero, "Distributed noise-resilient secondary voltage and frequency control for islanded microgrids," *IEEE Trans. Smart Grid*, vol. 10, no. 4, pp. 3780–3790, Jul. 2019, doi: [10.1109/TSG.2018.2834951](https://doi.org/10.1109/TSG.2018.2834951).
- [170] C. Zhao, W. Sun, J. Wang, Q. Li, D. Mu, and X. Xu, "Distributed cooperative secondary networked optimal control with packet loss for islanded microgrid," *IET Gener., Transmiss. Distrib.*, vol. 13, no. 20, pp. 4733–4740, Oct. 2019, doi: [10.1049/IET-GTD.2019.0472](https://doi.org/10.1049/IET-GTD.2019.0472).
- [171] A. Afshari, M. Karrari, H. R. Baghaee, and G. B. Gharehpetian, "Resilient cooperative control of AC microgrids considering relative state-dependent noises and communication time-delays," *IET Renew. Power Gener.*, vol. 14, no. 8, pp. 1321–1331, Jun. 2020, doi: [10.1049/IET-RPG.2019.1180](https://doi.org/10.1049/IET-RPG.2019.1180).
- [172] X. Lu, X. Yu, J. Lai, Y. Wang, and J. M. Guerrero, "A novel distributed secondary coordination control approach for islanded microgrids," *IEEE Trans. Smart Grid*, vol. 9, no. 4, pp. 2726–2740, Jul. 2018, doi: [10.1109/TSG.2016.2618120](https://doi.org/10.1109/TSG.2016.2618120).
- [173] C. Peng, H. Sun, M. Yang, and Y.-L. Wang, "A survey on security communication and control for smart grids under malicious cyber attacks," *IEEE Trans. Syst. Man, Cybern. Syst.*, vol. 49, no. 8, pp. 1554–1569, Aug. 2019, doi: [10.1109/TSMC.2018.2884952](https://doi.org/10.1109/TSMC.2018.2884952).
- [174] Q. Yang, J. Zhou, X. Chen, and J. Wen, "Distributed MPC-based secondary control for energy storage systems in a DC microgrid," *IEEE Trans. Power Syst.*, vol. 36, no. 6, pp. 5633–5644, Nov. 2021, doi: [10.1109/TPWRS.2021.3078852](https://doi.org/10.1109/TPWRS.2021.3078852).
- [175] C. Burgos-Mellado, J. Llanos, E. Espina, D. Sáez, R. Cárdenas, M. Sumner, and A. Watson, "Single-phase consensus-based control for regulating voltage and sharing unbalanced currents in 3-wire isolated AC microgrids," *IEEE Access*, vol. 8, pp. 164882–164898, 2020, doi: [10.1109/ACCESS.2020.3022488](https://doi.org/10.1109/ACCESS.2020.3022488).
- [176] P. Cai, C. Wen, and C. Song, "Consensus-based secondary frequency control for islanded microgrid with communication delays," in *Proc. Int. Conf. Control, Autom. Inf. Sci. (ICCAIS)*, Oct. 2018, pp. 107–112, doi: [10.1109/ICCAIS.2018.8570342](https://doi.org/10.1109/ICCAIS.2018.8570342).
- [177] H. Yan, X. Zhou, H. Zhang, F. Yang, and Z.-G. Wu, "A novel sliding mode estimation for microgrid control with communication time delays," *IEEE Trans. Smart Grid*, vol. 10, no. 2, pp. 1509–1520, Mar. 2019, doi: [10.1109/TSG.2017.2771493](https://doi.org/10.1109/TSG.2017.2771493).
- [178] Y. Niu, D. W. C. Ho, and J. Lam, "Robust integral sliding mode control for uncertain stochastic systems with time-varying delay," *Automatica*, vol. 41, no. 5, pp. 873–880, May 2005, doi: [10.1016/J.AUTOMATICA.2004.11.035](https://doi.org/10.1016/J.AUTOMATICA.2004.11.035).



FAWAD NAWAZ (Student Member, IEEE) received the bachelor's and master's degrees in electrical engineering from the University of Engineering and Technology, Taxila, Pakistan, in 2004 and 2009, respectively. He is currently pursuing the D.Eng. degree with the Engineering Institute of Technology, West Perth, Australia. His research interests include modern power system operation and their control strategies.



EHSAN PASHAJAVID (Senior Member, IEEE) has been joined the electrical and computer engineering discipline of Curtin University at Bentley campus since January 2022. Earlier on, he was with Central Queensland University as a Lecturer. He has also three years of work experience in the power industry. He has a demonstrated track record of research focused on microgrids, stochastic modeling, and optimization of renewable energy resources, electric vehicles, and power quality.



YUANYUAN FAN (Senior Member, IEEE) has always attached significance to social and environmental impacts in everyday work and research. She believes the future lies in the efficient utilization and management of renewable energy sources, from where other sustainable technologies, such as hydrogen production and usage, peer-to-peer energy trading will then become practical and cost-effective. The intelligent usage of massive amounts of data such as smart meters will

require high levels of data analytics skills of electrical engineers. Smart grids are the solution to a sustainable energy future, for which an electrical engineers should take the initiative to broaden their knowledge and in the meanwhile to collaborate with data communication engineers, automation engineers, data scientists, and policy-makers.



MUNIRA BATOOL (Senior Member, IEEE) received the bachelor's degree in electrical engineering from Bahauddin Zakariya University, Multan, Pakistan, in 2007, the master's degree in electrical engineering from the University of Engineering and Technology, Taxila, Pakistan, in 2012, and the Ph.D. degree in electrical engineering from Curtin University. Her research interests include renewable energy resource modeling and integration in electrical power system networks, standalone, and clustered MGs design for remote area networks with optimal operation.

...