

Received 10 June 2023, accepted 27 June 2023, date of publication 10 July 2023, date of current version 8 August 2023.

Digital Object Identifier 10.1109/ACCESS.2023.3293647

RESEARCH ARTICLE

New FxLMAT-Based Algorithms for Active Control of Impulsive Noise

ALINA MIRZA¹, FARKHANDA AFZAL², AYESHA ZEB³, ABDUL WAKEEL¹,
WAQAR SHAHID QURESHI⁴, AND ALI AKGUL^{5,6,7}¹Department of Electrical Engineering, Military College of Signals (MCS), National University of Sciences and Technology, Islamabad 44000, Pakistan²Department of Humanities and Basic Sciences, National University of Sciences and Technology, Islamabad 44000, Pakistan³Department of Mechatronics Engineering, College of Electrical and Mechanical Engineering (CEME), National University of Sciences and Technology, Islamabad 44000, Pakistan⁴Centre for Sustainable Digital Technologies, School of Computer Science, Technological University Dublin, Dublin 7, D07 H6K8 Ireland⁵Department of Computer Science and Mathematics, Faculty of Arts and Science, Lebanese American University, Beirut, Lebanon⁶Department of Mathematics, Faculty of Arts and Science, Siirt University, 56100 Siirt, Turkey⁷Mathematics Research Center, Department of Mathematics, Near East University, 99138 Nicosia, Mersin, Turkey

Corresponding author: Waqar Shahid Qureshi (waqar.shahid@tudublin.ie)

This work was supported by the Open Access funding provided by the IReL Consortium.

ABSTRACT In the presence of non-Gaussian impulsive noise (IN) with a heavy tail, active noise control (ANC) algorithms often encounter stability problems. While adaptive filters based on the higher-order error power principle have shown improved filtering capability compared to the least mean square family algorithms for IN, however, the performance of the filtered-x least mean absolute third (FxLMAT) algorithm tends to degrade under high impulses. To address this issue, this paper proposes three modifications to enhance the performance of the FxLMAT algorithm for IN. To improve stability, the first alteration i.e. variable step size FxLMAT (VSSFxLMAT) algorithm is suggested that incorporates the energy of input and error signal but has slow convergence. To improve its convergence, the second modification i.e. filtered x robust normalized least mean absolute third (FxRNLMAT) algorithm is presented but still lacks robustness. Therefore, a third modification i.e. modified filtered-x RNLMAT (MFxRNLMAT) is devised, which is relatively stable when encountered with high impulsive noise. With comparable computational complexity, the proposed MFxRNLMAT algorithm gives better robustness and convergence speed than all variants of the filtered-x least cos hyperbolic algorithm, and filtered-x least mean square algorithm.

INDEX TERMS Adaptive signal processing, non-Gaussian, mean noise reduction.

I. INTRODUCTION

In recent years, researchers have extensively employed a simple filtered-x least mean square (FxLMS) based active noise control (ANC) system to effectively reduce low-frequency noises [1], [2]. However, the performance of the FxLMS algorithm suffers when encountered with impulsive noise (IN), especially in the applied applications i.e. engines, punching, stamping machines, IV pumps, and all types of man-made noises [3], [4]. Impulsive noise exists with large amplitude for a shorter duration and can affect human health and communication systems [5]. Impulsive noise is formulated as symmetric alpha-stable distributions ($S\alpha S$), defined

The associate editor coordinating the review of this manuscript and approving it for publication was Mohamed M. A. Moustafa¹.

in Eq. 1 [6]:

$$\varphi(t) = \exp^{-\gamma|t|^\alpha} \quad (1)$$

The scale constraint (γ) of the $S\alpha S$ distribution is set to 1, to make the standard distribution. In Eq. 1, characteristic exponent (α) controls the expansion of probability density function (PDF) by varying its value between 0 and 2, i.e. α value closer to zero represents noise with more impulsive case and labels as a normal distribution for $\alpha = 2$. The effect of varying α on PDFs of $S\alpha S$ distribution is depicted in Fig. 1. Minimization of a certain cost function is the elementary principle of adaptive filters [7]. In the FxLMS algorithm, the cost function is the mean square error supposing the error produced is Gaussian, i.e. variance is finite. Nevertheless, when faced with impulsive input, the FxLMS algorithm is not

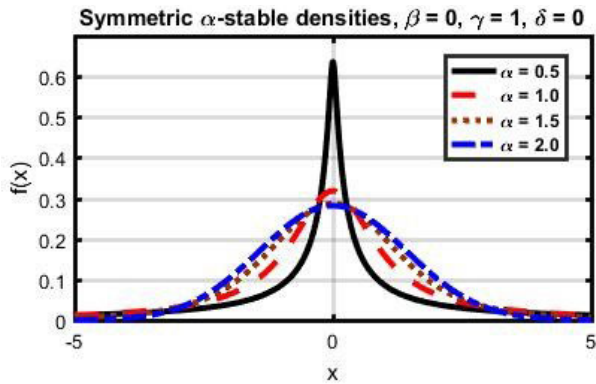

FIGURE 1. Symmetric alpha stable distributions with varying alpha (α).

optimal for reducing impulsive noise (IN) due to its instability caused by an infinite variance.

Researchers have suggested various solutions for the FxLMS algorithm to achieve stability in the presence of IN. To ensure stability where high peak impulses are encountered, reformed filtered x least mean M-estimator method [8] and trimmed mean FxLMS algorithm [9] were proposed in the literature. In [10], the Volterra filter-x maximum correntropy criterion (VF×MCC) algorithm and Volterra filter-x recursive maximum correntropy (VF×RMC) algorithm were utilized in a non-linear active noise control (NANC) system to improve the stability of the Volterra filter when dealing with impulsive noise (IN). Furthermore, another feed-forward ANC algorithm based on an information-theoretic learning framework, incorporating the data-reuse scheme of affine-projection-based algorithms, was introduced in a separate publication [11]. It successfully achieved the robustness of maximum correntropy criterion-based ANC algorithms against IN and the rapid fast convergence of AP-based algorithms.

In [12], a robust modified gain filtered-x recursive least square (MGFxRLS) algorithm was presented to improve the robustness of the filtered-x recursive least square (FxRLS) algorithm [13]. It is well known that for impulsive environments, RLS-based algorithms have better convergence and steady-state error if compared to all LMS-based algorithms [7] but at the cost of increased computational complexity. A less complex modified filtered-x least cosine hyperbolic (MFxLCH) algorithm for ANC of IN was suggested to enhance stability and convergence of the FxLCH algorithm in [14].

Moreover, high-order error power (HOEP) adaptive filters reduce the higher power of the error signal. In [15], [16], and [17], the least mean absolute third (LMAT) algorithm as the name represents decreases the 3rd power of the error signal. The error produced in the LMAT algorithm is a convex function of filter weights therefore, for various distributions LMAT algorithm outperforms the LMS algorithm. Similarly, various modified versions of the LMAT algorithm have been proposed in the literature to improve its performance under different applications. One such improvement i.e. a robust

sparse normalized LMAT algorithm was suggested which provides robustness against impulsive noise [18]. In [19], a robust normalized least mean absolute third (RNLMAT) algorithm was introduced that solves the stability issues of the LMAT algorithm under different noise environments in system identification problems. Motivated by such performance findings [15], [16], [17], [18], [19], authors in [20] proposed filtered-x LMAT (FxLMAT) algorithm for ANC of IN and achieved faster convergence than FxLMS algorithm. However, the FxLMAT algorithm becomes unstable in case of high impulses. Further, two threshold-based modifications i.e. sample ignored FxLMAT and sample clipped FxLMAT algorithms, were presented to improve the convergence and stability of the FxLMAT algorithm. One of the concerns with these modifications was their dependency on an appropriate selection of thresholds, which is not possible during online ANC operation therefore, there is a need to further investigate threshold-independent solutions for improving the performance of the FxLMAT algorithm in the ANC domain.

Efficient control of IN demands ANC algorithms that are fast (in terms of steady-state convergence), robust to noise changes, achieve minimum residual error, and above all, should have the least computational complexity. In an attempt to find robust solutions for ANC of IN, initially, we tested a threshold-independent modification in the FxLMAT algorithm to enhance its stability. The proposed alteration is a variable step size FxLMAT (VSSFxLMAT) algorithm, which incorporates the energy of the error signal in calculating the step size of the FxLMAT algorithm. In addition to that, the RNLMAT algorithm [19] renders better noise mitigation ability and low complexity. However, it has never been tested in the ANC domain. Therefore, the RNLMAT algorithm has been tested in the ANC system in this paper and is given the name, filtered-x robust normalized LMAT (FxRNLMAT) algorithm due to its combination with the filtered reference input. The simulation results indicated that the algorithm's robustness is limited in highly impulsive environments, but it performs well in less impulsive scenarios. To further improve both robustness and convergence speed, a modification is introduced to adjust the step size of the FxRNLMAT algorithm, resulting in the development of the MFXRNLMAT algorithm. Extensive simulations conducted during this research demonstrate that the proposed MFXRNLMAT algorithm outperforms all other investigated algorithms in terms of stability, convergence, and steady-state error.

The rest of the paper is summarized as Section II gives details of newly proposed algorithms, whereas, Section III provides the proposed algorithm's complexity analysis. Simulation results and performance comparisons of the proposed algorithms with existing solutions are provided in Section IV. Section V finally concludes the paper.

II. PROPOSED MODIFICATIONS

The FxLMAT algorithm is based on minimizing the mean of error third power i.e. the error function is the perfect

TABLE 1. List of variables employed in ANC system.

Symbols	Description
$\mathbf{x}(m)$	Reference noise
$\mathbf{x}_f(m)$	Filtered reference noise
$e_r(m)$	Error signal received by the error microphone
$k(m)$	Disturbance at error microphone
$\mathbf{P}_p(z)$	Transfer function of primary path
$\mathbf{S}_p(z)$	Transfer function of secondary path
$\hat{\mathbf{S}}_p(z)$	Estimated secondary path
$\mathbf{U}(m)$	Adaptive filter coefficients
$O(m)$	Output of adaptive filter
$O_f(m)$	Filtered output of adaptive filter

convex function of the filter weights. The cost function and the weight update equation used for a FxLMAT algorithm [20] are given in Eq. 2 and Eq. 3, respectively.

$$J(m) = 3e_r^2(m) \operatorname{sgn}[e_r(m)] \mathbf{x}(m) \quad (2)$$

$$\mathbf{U}(m+1) = \mathbf{U}(m) + \mu e_r^2(m) \operatorname{sgn}[e_r(m)] \mathbf{x}_f(m) \quad (3)$$

In Eq. 2, $J(m)$ represents the cost function, sgn is the sign function, and $\mathbf{x}(m)$ is the reference noise. Whereas, in Eq. 3, $\mathbf{U}(m+1)$ refer to the weight at the $(m+1)^{th}$ iteration, μ represents the step size, $e_r(m)$ is the error at the m^{th} iteration, and $\mathbf{x}_f(m)$ is the filtered reference noise, where, $\mathbf{x}_f(m) = [x_f(m), x_f(m-1), \dots, x_f(m-Lp+1)]^T$.

In Eq. 3, when a large amplitude impulse is encountered in the filtered reference signal $\mathbf{x}_f(m)$ at instant m , the value of $\mathbf{U}(m+1)$ abruptly increases. This results in the instability of the algorithm and the algorithm performance is badly affected due to the existence of IN. Therefore, in this section, we present our three proficient modifications in the FxLMAT algorithm which enhances its performance in the presence of IN. The list of variables used in our proposed model is as shown in Table 1.

A. PROPOSED VSSFxLMAT ALGORITHM

As previously mentioned, the FxLMAT algorithm’s performance deteriorates when faced with impulsive noise (IN). To address this issue, this subsection introduces the first modification, namely the variable step size FxLMAT (VSS-FxLMAT) algorithm, which aims to overcome this limitation. The proposed VSSFxLMAT algorithm is based on the findings of [21]. The step size of the proposed VSSFxLMAT algorithm is normalized with respect to the input noise’s energy and the error signal’s energy. The new weight update equation along with variable step size is given in Eq. 4-Eq. 6, respectively.

$$\mathbf{U}(m+1) = \mathbf{U}(m) + \mu(m) e_r^2(m) \operatorname{sgn}[e_r(m)] \mathbf{x}_f(m) \quad (4)$$

$$\mu(m) = \frac{\mu}{\delta_2 + \|\mathbf{x}_f(m)\|^2 + T_e(m)} \quad (5)$$

$$T_e(m) = \lambda T_e(m-1) + (1-\lambda) e_r^2(m) \quad (6)$$

where δ_2 is a small positive constant being added to the denominator just to avoid division by zero in Eq. 5. Its value is chosen to be 0.1. Changing the value of δ_2 does not affect

the performance of the proposed algorithm as its only role is to avoid division by zero [21]. A low pass estimator $T_e(m)$ is used to compute the energy of the error signal as given in Eq. 6, where, λ is the forgetting factor. The range of λ is defined in the literature as $(0.9 < \lambda < 1)$ [21]. The higher value of λ means more weightage to the past values of the accumulated error samples and a lower value means more weightage is given to the current value of the error samples.

In Eq. 5, if an impulse is encountered at instant m , the energy of the filtered input sample $\mathbf{x}_f(m)$ as well as the error signal $e_r(m)$ greatly increases, and thus the step size decreases. This decrease in step size value for that instant m momentarily halts the adaptation of the weight update mechanism in Eq. 4, thus preventing an abrupt change in updated weights $\mathbf{U}(m+1)$, which in turn results in enhanced stability of the algorithm.

Extensive simulations indicate that the proposed VSS-FxLMAT algorithm exhibits enhanced stability performance. However, its convergence becomes slow due to the weight update mechanism being frozen. To overcome this issue of slow convergence, a new algorithm called FxRNLMAT is devised in the subsequent subsection.

B. PROPOSED FxRNLMAT ALGORITHM

According to the literature [19], the RNLMAT algorithm demonstrates improved convergence speed and robustness across different impulsive noise (IN) environments. The normalization term, which corresponds to the third order of $e_r(m)$ [16], effectively controls the unboundedness of the input reference noise signal and mitigates the increase in input variance. Whenever the value of error sample $e_r(m)$ increases due to encountered impulses in the reference signal, the normalization term $\frac{1}{1+\beta_2|e_r(m)|^3}$ approaches zero, thus controlling the increase in weight $\mathbf{U}(m+1)$ and preventing the algorithm from diverging. Motivated by these findings, we, therefore, tested the same algorithm for ANC of IN by incorporating filtered reference input $\mathbf{x}_f(m)$ in the paper, thus named as proposed filtered-x RNLMAT (FxRNLMAT) algorithm. The block diagram for the proposed FxRNLMAT is shown in Fig. 2. $\mathbf{P}_p(z)$ and $\mathbf{S}_p(z)$ are used to represent primary and secondary paths. The reference signal $\mathbf{x}(m)$ is filtered through the secondary estimated path filter $\hat{\mathbf{S}}_p(z)$. The weight update equation of the proposed FxRNLMAT algorithm is:

$$\mathbf{U}(m+1) = \mathbf{U}(m) + \mu(m) e_r^2(m) \operatorname{sgn}[e_r(m)] \mathbf{x}_f(m) \quad (7)$$

$$\mu(m) = \frac{\mu}{1 + \beta_2 |e_r(m)|^3} \quad (8)$$

where β_2 is greater than zero, i.e. $(\beta_2 > 0)$ in Eq. 7 [19]. β_2 together with step size μ can balance the transient and steady-state performance when an impulse is encountered [19]. The proposed FxRNLMAT algorithm achieves better convergence and low steady steady-state error than that of the proposed VSSFxLMAT algorithm however, in the presence of more impulsive noise, it lacks robustness. In order to improve its robustness, a new algorithm is proposed in

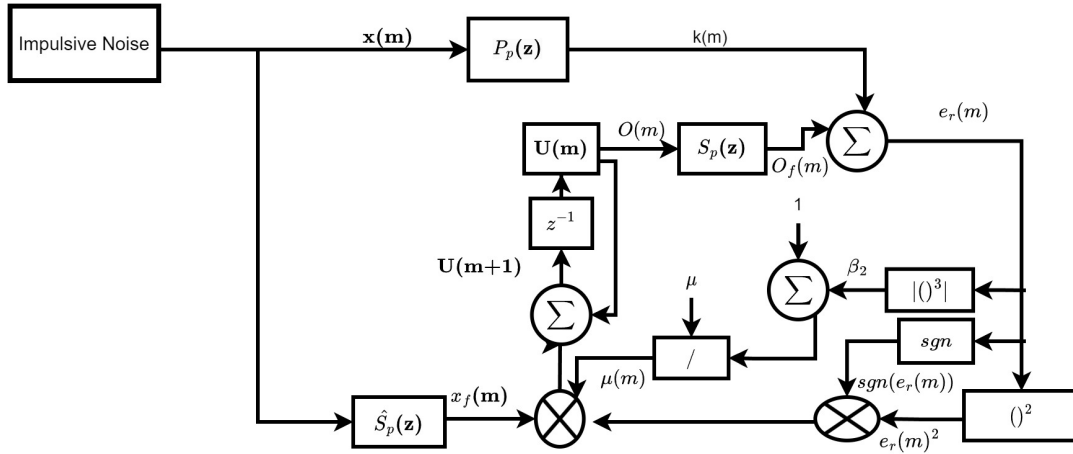

FIGURE 2. Proposed FxRNLMAT algorithm-based ANC system.

TABLE 2. Summarized complexity analysis of the observed algorithms.

Algorithm	*	+/-	/
FxLMS [2]	$2L_p + 2M_s + 1$	$2L_p + 2M_s - 2$	---
NSSFxLMS [21]	$3L_p + 2M_s + 4$	$3L_p + 2M_s + 1$	1
MFxLCH [14]	$3L_p + 2M_s + 5$	$3L_p + 2M_s + 2$	2
	$3L_p + 2M_s + 7$	$3L_p + 2M_s + 3$	2
MGFxRLS [12]	$4L_p^2 + 4L_p + 2M_s + 3$	$3L_p^2 + L_p + 2M_s + 1$	2
FxLMAT [20]	$2L_p + 2M_s + 3$	$2L_p + 2M_s - 2$	—
Proposed VSSFxLMAT	$3L_p + 2M_s + 5$	$3L_p + 2M_s + 1$	1
Proposed FxRNLMAT	$2L_p + 2M_s + 6$	$2L_p + 2M_s - 1$	1
Proposed MFxRNLMAT	$3L_p + 2M_s + 9$	$3L_p + 2M_s + 4$	2

TABLE 3. Set of simulation parameters.

ANC System		
Parameters	Symbols	Values
Primary path coefficients	L_p	256
Secondary path coefficients	M_s	12
Adaptive filter coefficients	L_a	192
Lambda for Proposed VSSFxLMAT and Proposed MFxRNLMAT algorithms	λ	0.9999
Delta for proposed VSSFxLMAT and proposed MFxRNLMAT algorithms	δ_2	0.1
Beta for proposed FxRNLMAT and proposed MFxRNLMAT algorithms	β_2	0.1
Impulsive Noise		
Parameters	Symbols	Values
Total samples	N_s	40,000
Total realizations	Avg	10
Characteristic exponent	α	1.85, 1.65, 1.45

TABLE 4. Alpha (α) values for different cases.

Cases	Alpha(α) value
Case 1	$\alpha=1.65$
Case 2	$\alpha=1.45$
Case 3	$\alpha=1.85, 1.45, 1.65$

the next sub-section as the last main contribution of this research work, which modifies the step size of the proposed FxRNLMAT algorithm.

C. PROPOSED MFxRNLMAT ALGORITHM

The robustness of the proposed FxRNLMAT algorithm is improved further by normalizing the step size of FxRNLMAT

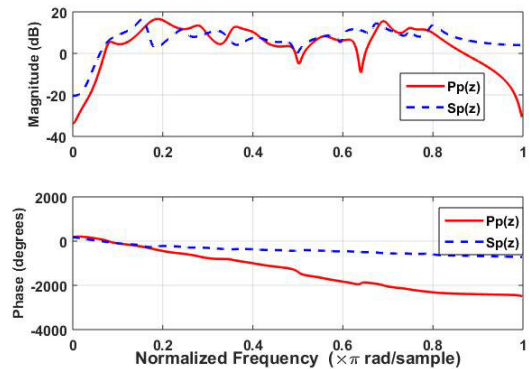

FIGURE 3. Frequency response of primary and secondary acoustic paths.

with respect to the energy of input noise and error signal, thus proposing a modified FxRNLMAT (MFxRNLMAT) algorithm. The updated weight equations for the proposed MFxRNLMAT along with step size are given in Eq. 9-11, respectively.

$$U(m+1) = U(m) + \left(\frac{\mu(m)}{1 + \beta_2 |e_r(m)|^3} \right) \times e_r^2(m) \text{sgn}[e_r(m)] \mathbf{x}_f(m). \quad (9)$$

$$\mu(m) = \frac{\mu}{\delta_2 + \|\mathbf{x}_f(m)\|^2 + T_e(m)} \quad (10)$$

$$T_e(m) = \lambda T_e(m-1) + (1 - \lambda) e_r^2(m) \quad (11)$$

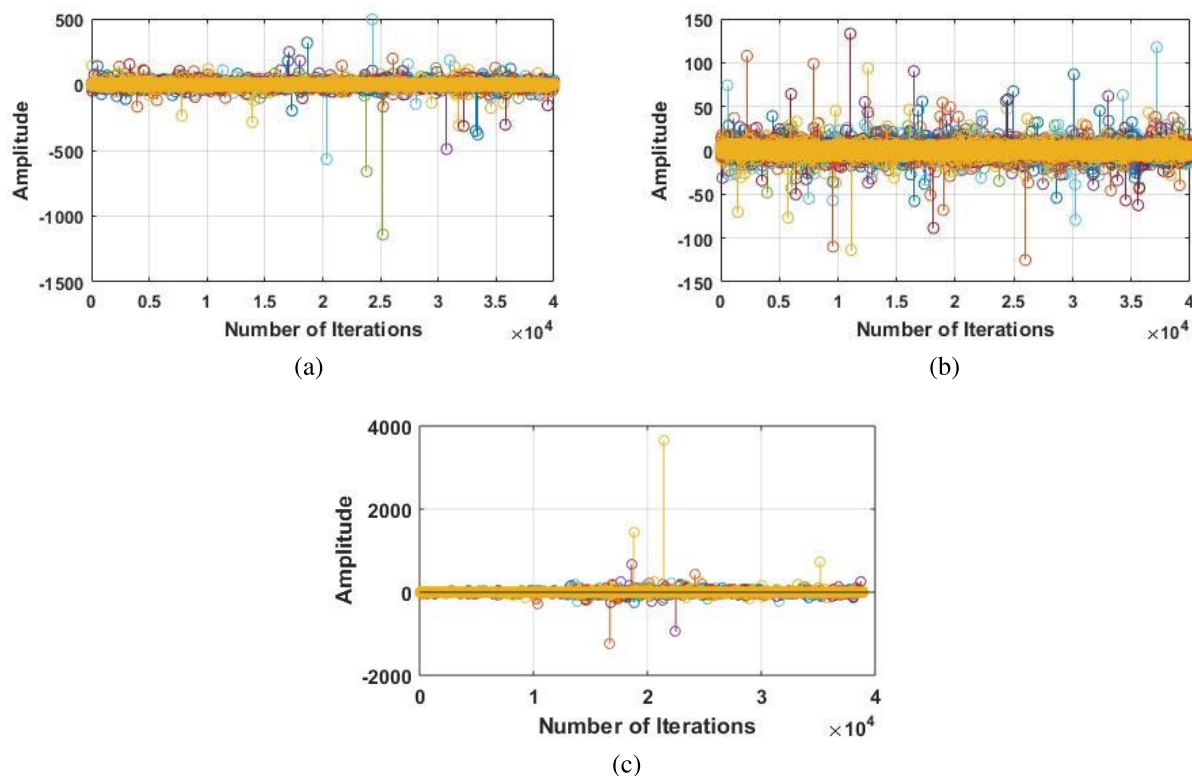

FIGURE 4. Primary noise for (a) case 1, (b) case 2, (c) case 3.

TABLE 5. Optimum controlling parameters of investigated algorithms for all cases.

Algorithm	Controlling parameter	(Case 1)	(Case 2)	(Case 3)	(Case 4)
NSSFxLMS [21]	μ	5×10^{-2}	5×10^{-2}	1×10^{-1}	5×10^{-2}
MFxLCH [14]	μ	5×10^{-1}	5×10^{-1}	5×10^{-1}	5×10^{-1}
MGFxRLS [12]	δ	1000	10,000	100	1000
FxLMAT [20]	μ	1×10^{-7}	1×10^{-7}	5×10^{-7}	1×10^{-7}
Proposed VSSFxLMAT	μ	1×10^{-4}	1×10^{-2}	1×10^{-3}	1×10^{-4}
Proposed FxRNLMAT	μ	5×10^{-6}	5×10^{-6}	1×10^{-5}	5×10^{-6}
Proposed MFxRNLMAT	μ	5×10^{-1}	5×10^{-1}	5×10^{-1}	5×10^{-1}

The proposed MFxRNLMAT algorithm gives better performance in terms of enhanced robustness, faster convergence, and reduced steady-state error than the previously proposed algorithms even in case of high impulses. The enhanced performance of the proposed MFxRNLMAT algorithm compared to other proposed and investigated algorithms are validated through extensive simulations.

III. COMPLEXITY ANALYSIS

This paper introduces different variations of the FxLMAT algorithm to address active noise control (ANC) of impulsive sources modeled as symmetric α -stable ($S\alpha S$) distributions. It is worth noting that for impulsive noise, second-order moments do not exist [22]. Computing lower-order moments is more challenging compared to second-order moments [23], which poses difficulties in theoretical analysis,

if not rendering it impossible. Therefore, non-Gaussian signal processing is quite complicated in terms of calculating statistics than Gaussian signals. This may be the reason that recent research on ANC of impulsive sources (modeled as a stable process) does not include the theoretical analysis, and in fact, the simulations are the major tool to prove the effectiveness of the proposal (see, for example, [21], [24], [25], [26], [27]). In this paper, we have also used computer simulations as the evaluation tool and it is observed that the proposed algorithm outperforms the existing algorithms.

In real-time applications, the computational complexity of any algorithm is very important. Table 2 summarizes the complexity of the proposed VSSFxLMAT, FxRNLMAT, and MFxRNLMAT algorithms along with the already existing algorithms. L_p and M_s represent the number of filter coefficients of the primary and secondary paths, respectively.

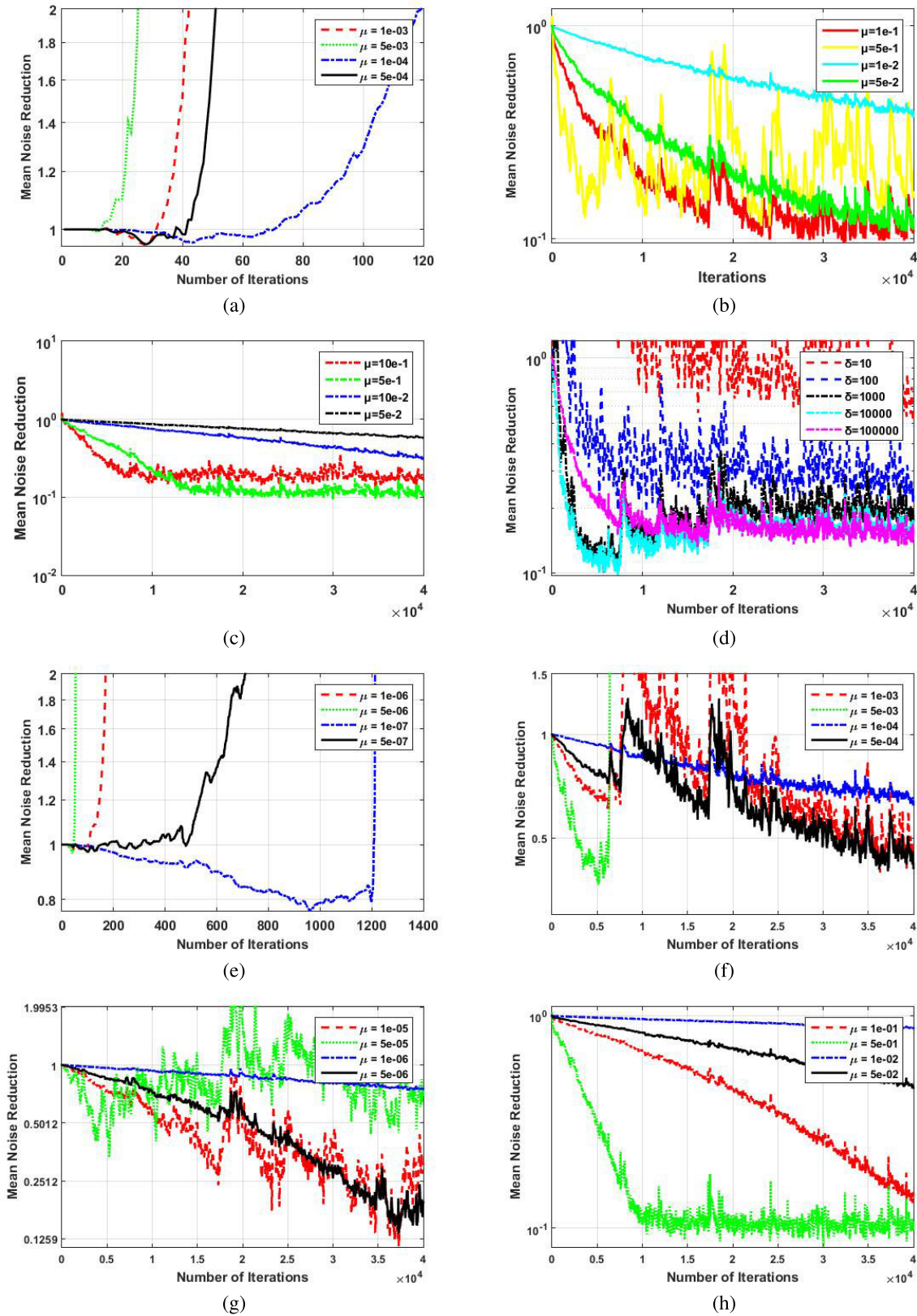

FIGURE 5. MNR curves for case 2 (a) FxLMS algorithm, (b) NSSFxLMS algorithm, (c) MFxLCH algorithm, (d) MGFxRLS algorithm, (e) FxLMAT algorithm, (f) Proposed VSSFxLMAT algorithm, (g) Proposed FxRNLMAT algorithm, (h) Proposed MFxRNLMAT algorithm.

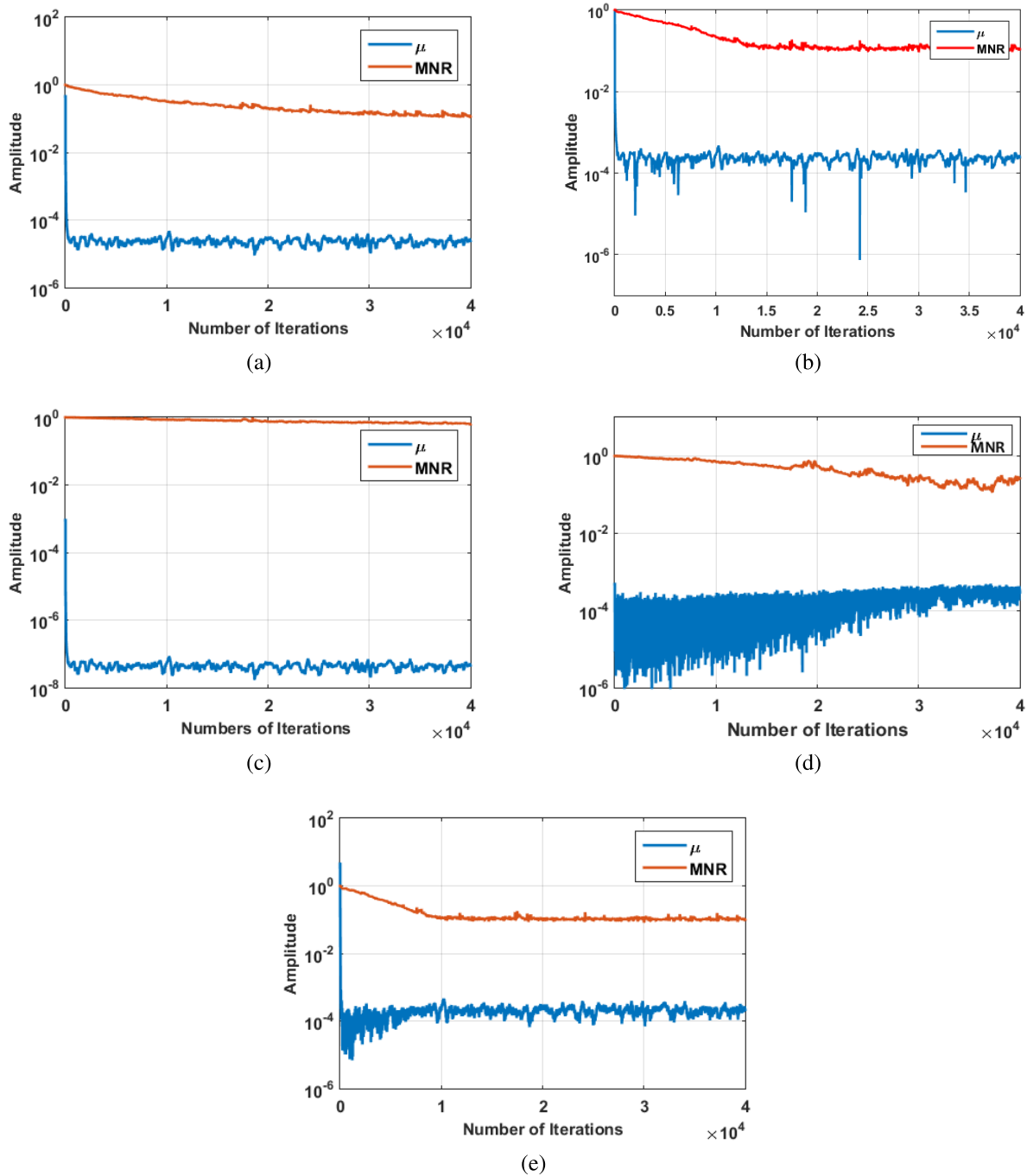

FIGURE 6. Comparison of varying step size and MNR for a) NSSFxLMS (b) MFxLCH (c) Proposed VSSFxLMAT (d) Proposed FxRNLMAT (e) Proposed MFxRNLMAT algorithms.

The proposed FxRNLMAT algorithm has nearly the same complexity as the FxLMS algorithm, whereas the proposed VSSFxLMAT and MFxRNLMAT algorithms show similar complexity as the NSSFxLMS algorithm respectively. The FxLMS algorithm is widely used in many applications due to its less complexity. Table 2 reveals that the proposed algorithms can be a good alternative for the FxLMS algorithm in practical applications owing to their computational compatibility with the FxLMS algorithm.

IV. SIMULATION RESULTS

MATLAB platform was used for the simulations of ANC for IN in this research. Algorithms that are taken into account for comparison are the FxLMS algorithm [2], NSSFxLMS algorithm [21], MGFxRLS algorithm [12], MFxLCH algorithm [14], FxLMAT algorithm [20]. In this paper, three cases of impulsive noise [6] using $S\alpha S$ process are considered. All the statistical parameters of IN and ANC systems are tabulated in Table 3. Moreover, the secondary path, $S_P(z)$ and

estimated secondary path, $\hat{S}_p(z)$ is considered to be equal [8], [9], [12], [13], [14], [21], [24]. The magnitude and phase responses of the filters, i.e. primary and secondary, are given in Fig. 3. The superior performance of the proposed algorithm among the investigated algorithms is validated through mean noise reduction (MNR), which is used as the performance metric and is calculated as:

$$MNR(m) = E \left\{ \frac{T_{e_r}(m)}{T_k(m)} \right\} \quad (12)$$

Here, E, defines the expectation of the value

$$T_{e_r}(m) = \lambda T_{e_r}(m-1) + (1-\lambda) |e_r(m)| \quad (13)$$

$$T_k(m) = \lambda T_k(m-1) + (1-\lambda) |k(m)| \quad (14)$$

where $T_{e_r}(m)$ denotes the estimated absolute values of residual error. While the estimated absolute values of the disturbance signal are denoted by $T_k(m)$. Three values of α are selected to generate three different cases of IN, which are given in Table 4, representing a less impulsive environment in case 1 and gradually moving towards more impulsive cases, i.e. case 2. Case 3 depicts non-stationary noise, i.e. α is time varying i.e. $\alpha = 1.85$ such that $m \leq 13000$, $\alpha = 1.45$, such that $13000 < m \leq 26000$, and finally $\alpha = 1.65$ such that $26000 < m \leq 39000$. Moreover, the behavior of all the investigated algorithms for varying primary paths is depicted in case 4.

Fig. 4 illustrates the primary noise for the first three cases. To procure the ultimate values of controlling parameters of discussed algorithms inclusive simulations are carried out for all discussed cases, however, the detailed results are shown only for case 2 in this paper (Fig. 5 (a-h)). The selected values of controlling parameters from rigorous simulations are listed in Table 5 of all three noise cases.

Moreover, the evolution of step size and MNR curves are carried out for the proposed algorithms in Fig. 6. It can be seen that at the start the step size of investigated algorithms decreases instantly in an attempt to minimize the error and afterward minor adjustments in the step size are being carried out by the algorithm so that minimum error can be achieved. In Fig. 7, the MNR curve for the FxLMAT algorithm is compared with the standard FxLMS algorithm. It can be seen that the FxLMS algorithm diverges for case 1, whereas the FxLMAT algorithm is stable with a slow convergence speed. Three algorithms are proposed in this research paper for improving the performance of the FxLMAT algorithm.

It is evident from the literature that NSSFxLMS [21] outperforms all other algorithms in the FxLMS family. It can be gauged on its stability and convergence speed. Moreover, faster convergence and low steady-state error of the MGFxRLS algorithm are also proved in [12]. The MFxLCH algorithm is a good tradeoff between NSSFxLMS and MGFxRLS algorithm in terms of computational complexity, steady-state error, and convergence speed [14]. Therefore, a comparison of all proposed i.e. VSSFxLMAT, FxRNL-MAT, and MFxRNL-MAT algorithms is carried out with NSSFxLMS, MFxLCH, and MGFxRLS algorithms for all three cases.

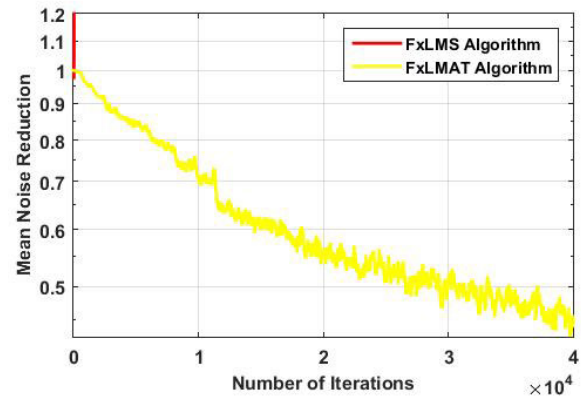

FIGURE 7. MNR curves evaluation for FxLMAT and FxLMS algorithm for case1.

A. CASE-1 AND CASE 2

Fig. 8 (a-b) presents the comparison of MNR curves of the proposed algorithms with already existing algorithms i.e. NSSFxLMS, MGFxRLS, and MFxLCH algorithm for more impulsive environment $\alpha = 1.65$ and $\alpha = 1.45$, respectively. It can be seen that the FxLMAT algorithm becomes unstable and diverges at 15000 iterations in the presence of high impulses, whereas the proposed VSSFxLMAT algorithm does not diverge but rather shows very slow convergence. The other proposed FxRNL-MAT algorithm shows better convergence than that of the proposed VSSFxLMAT algorithm and attains steady-state error of the MGFxRLS algorithm after almost 25,000 iterations for case 1, but still encounters robustness issues in case 2. However, the proposed MFxRNL-MAT algorithm outperforms the other two proposed variants in terms of enhanced robustness, low steady-state error, and fastest convergence. Furthermore, the convergence speed and robustness of the proposed MFxRNL-MAT algorithm are much better than that of the NSSFxLMS and MFxLCH algorithm and also acquires steady-state error of the MGFxRLS algorithm at about 1000 iterations. Moreover, it is worth mentioning that the performance of the proposed MFxRNL-MAT algorithm approaches that of the MGFxRLS algorithm in terms of stability, convergence speed, and robustness with remarkably low computational complexity as compared to the MGFxRLS algorithm.

B. CASE-3 AND CASE-4

In order to further compare the stability and robustness of proposed algorithms with the investigated algorithms, case 3 and case 4 are designed to depict a non-stationary environment during run time application. For a fixed alpha case, all the investigated and proposed algorithms are initialized with the optimum step size value for each particular alpha value. If during run time application noise level changes then the algorithms cannot be reinitialized with the corresponding optimum value of step size for that particular alpha. Hence, serves as a challenging noise environment for the algorithms. It can be seen from Fig. 8 (c) that after 10000 iterations when noise becomes relatively more impulsive, FxLMAT and proposed VSSFxLMAT algorithms become unstable and

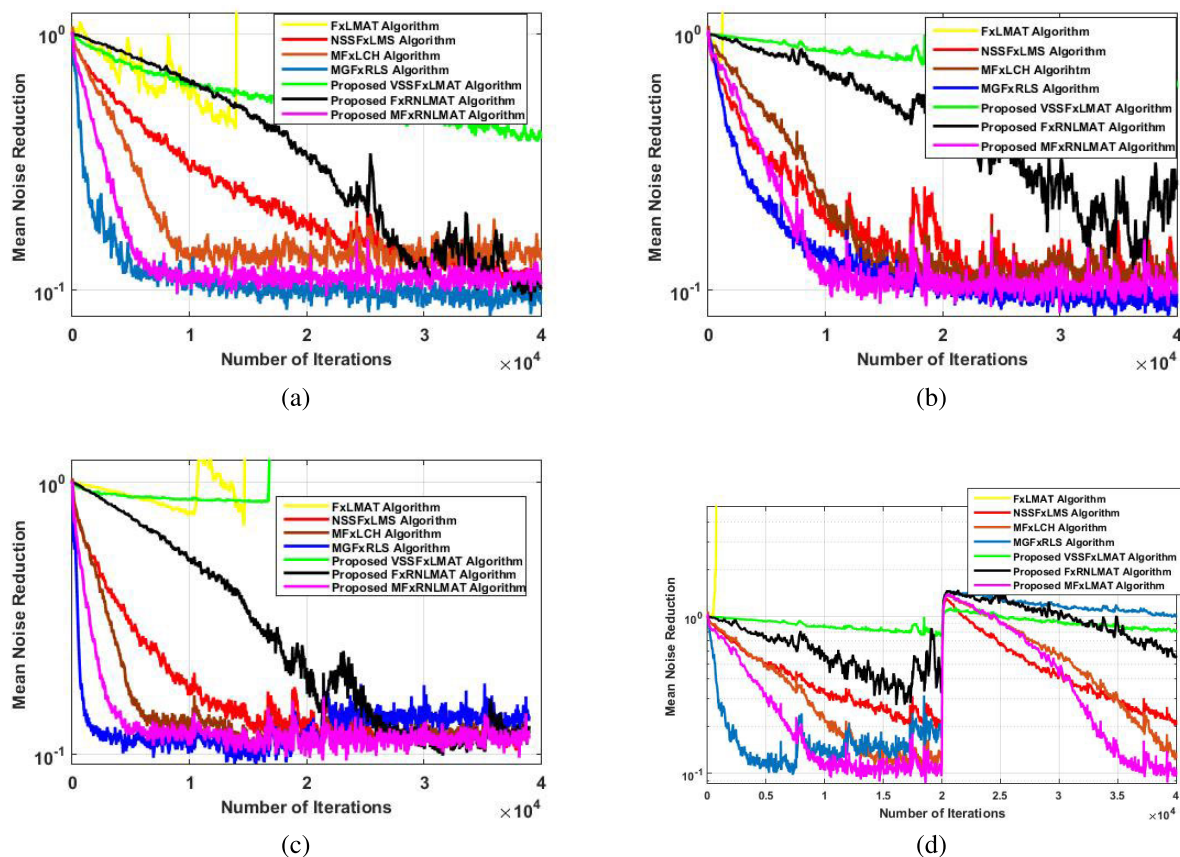

FIGURE 8. MNR curve evaluation of proposed algorithms (a) case-1 (b) case-2, (c) case-3 (d) case-4.

thus diverge. The proposed FxRNLMAT algorithm tends to converge however, relatively less robust as compared to NSSFxLMS, MFxLCH, proposed MFxRNLMAT, and MGFxRLS algorithms. Furthermore, when the primary path is varied at 2000 iterations in Fig. 8 (d), it can be seen that all the investigated and proposed algorithms initially diverge but start converging again to achieve minimum MNR value. However, the proposed MFxRNLMAT algorithm is quite stable and robust even under time-varying characteristics of noise and primary path changes. Moreover, the proposed MFxRNLMAT algorithm attains the convergence speed of the MGFxRLS algorithm with reduced computational complexity as compared to the MGFxRLS algorithm.

V. CONCLUSION

This paper explores the application of high-order error power (HOEP) adaptive filters in active noise control (ANC) for impulsive noise (IN). It is observed that the filtered-x least mean absolute third algorithm (FxLMAT) exhibits instability when confronted with high levels of IN. To address this issue, a robust algorithm is proposed, called the modified filtered-x robust normalized least mean absolute third (MFxRNLMAT) algorithm. This algorithm incorporates the utilization of noise and error signal energy to dynamically adjust the step size for each iteration. Rigorous simulations are conducted to

evaluate the performance of the proposed MFxRNLMAT algorithm, and the results demonstrate its superiority in terms of convergence speed, stability, and robustness compared to other algorithms investigated in the study.

REFERENCES

- [1] S. M. Kuo and D. R. Morgan, "Active noise control: A tutorial review," *Proc. IEEE*, vol. 87, no. 6, pp. 943–973, Jun. 1999.
- [2] M. García, D. Patiño, and R. Quintana, "DSP implementation of the FxLMS algorithm for active noise control: Texas instruments TSM320C6713DSK," in *Proc. IEEE 2nd Colombian Conf. Autom. Control (CCAC)*, Oct. 2015, pp. 1–6.
- [3] Y. L. Zhou, Y. X. Yin, and Q. Z. Zhang, "An optimal repetitive control algorithm for periodic impulsive noise attenuation in a non-minimum phase ANC system," *Appl. Acoust.*, vol. 74, no. 10, pp. 1175–1181, Oct. 2013.
- [4] L. Liu, S. Gujjula, P. Thanigai, and S. M. Kuo, "Still in womb: Intrauterine acoustic embedded active noise control for infant incubators," *Adv. Acoust. Vib.*, vol. 2008, pp. 1–9, Apr. 2008.
- [5] S. Chen, F. Gu, C. Liang, H. Meng, K. Wu, and Z. Zhou, "Review on active noise control technology for α -stable distribution impulsive noise," *Circuits, Syst., Signal Process.*, vol. 41, no. 2, pp. 956–993, Feb. 2022.
- [6] M. Shao and C. L. Nikias, "Signal processing with fractional lower order moments: Stable processes and their applications," *Proc. IEEE*, vol. 81, no. 7, pp. 986–1010, Jul. 1993.
- [7] S. S. Haykin, *Adaptive Filter Theory*. Noida, India: Pearson, 2008.
- [8] P. Li and X. Yu, "Active noise cancellation algorithms for impulsive noise," *Mech. Syst. Signal Process.*, vol. 36, no. 2, pp. 630–635, Apr. 2013.
- [9] D.-C. Chang and P.-W. Chiang, "Trimmed-mean FxLMS algorithm for ANC in impulsive noise," in *Proc. Asia-Pacific Signal Inf. Process. Assoc. Annu. Summit Conf. (APSIPA ASC)*, Nov. 2018, pp. 1268–1271.

- [10] Z. C. He, H. H. Ye, and E. Li, "An efficient algorithm for nonlinear active noise control of impulsive noise," *Appl. Acoust.*, vol. 148, pp. 366–374, May 2019.
- [11] Y.-R. Chien, C.-H. Yu, and H.-W. Tsao, "Affine-projection-like maximum correntropy criteria algorithm for robust active noise control," *IEEE/ACM Trans. Audio, Speech, Language Process.*, vol. 30, pp. 2255–2266, 2022.
- [12] A. Zeb, A. Mirza, Q. U. Khan, and S. A. Sheikh, "Improving performance of F×RLS algorithm for active noise control of impulsive noise," *Appl. Acoust.*, vol. 116, pp. 364–374, Jan. 2017.
- [13] A. Zeb, A. Mirza, and S. A. Sheikh, "Filtered-x RLS algorithm based active noise control of impulsive noise," in *Proc. 7th Int. Conf. Modelling, Identificat. Control (ICMIC)*, Dec. 2015, pp. 1–5.
- [14] A. Mirza, A. Zeb, M. Yasir Umair, D. Ilyas, and S. A. Sheikh, "Less complex solutions for active noise control of impulsive noise," *Anal. Integr. Circuits Signal Process.*, vol. 102, no. 3, pp. 507–521, Mar. 2020.
- [15] S. H. Cho and S. D. Kim, "Adaptive filters based on the high order error statistics," in *Proc. Asia Pacific Conf. Circuits Syst. (APCCAS)*, Nov. 1996, pp. 109–112.
- [16] S. H. Cho, S. D. Kim, H. P. Moom, and J. Y. Na, "Least mean absolute third (LMAT) adaptive algorithm: Mean and mean-squared convergence properties," in *Proc. 6th Western Pacific Region Acoust. Conf.*, vol. 22, Hong Kong, 1997, pp. 2303–2309.
- [17] Y. H. Lee, J. D. Mok, S. D. Kim, and S. H. Cho, "Performance of least mean absolute third (LMAT) adaptive algorithm in various noise environments," *Electron. Lett.*, vol. 34, no. 3, pp. 241–243, 1998.
- [18] R. Pogula, T. K. Kumar, and F. Albu, "Robust sparse normalized LMAT algorithms for adaptive system identification under impulsive noise environments," *Circuits, Syst., Signal Process.*, vol. 38, no. 11, pp. 5103–5134, Nov. 2019.
- [19] K. Xiong, S. Wang, and B. Chen, "Robust normalized least mean absolute third algorithms," *IEEE Access*, vol. 7, pp. 10318–10330, 2019.
- [20] A. Hussain, A. Mirza, A. Zeb, and M. Y. Umair, "A modified filtered-x LMAT algorithm for active noise control of impulsive noise," in *Proc. IEEE Int. Symp. Signal Process. Inf. Technol. (ISSPIT)*, Dec. 2019, pp. 1–6.
- [21] M. T. Akhtar and W. Mitsuhashi, "A modified normalized F×LMS algorithm for active control of impulsive noise," in *Proc. 18th Eur. Signal Process. Conf.*, Aug. 2010, pp. 1–5.
- [22] C. L. Nikias and M. Shao, *Signal Processing With Alpha-Stable Distributions and Applications*, Hoboken, NJ, USA: Wiley, 1995.
- [23] M. T. Akhtar, "Binormalized data-reusing adaptive filtering algorithm for active control of impulsive sources," *Digit. Signal Process.*, vol. 49, pp. 56–64, Feb. 2016.
- [24] M. Tahir Akhtar and W. Mitsuhashi, "Improving performance of F×LMS algorithm for active noise control of impulsive noise," *J. Sound Vib.*, vol. 327, nos. 3–5, pp. 647–656, Nov. 2009.
- [25] Z. Bo, C. Sun, Y. Xu, and S. Jiang, "A variable momentum factor filtered-x weighted accumulated LMS algorithm for narrowband active noise control systems," *Measurement*, vol. 48, pp. 282–291, Feb. 2014.
- [26] S. B. Behera, D. P. Das, and N. K. Rout, "Nonlinear feedback active noise control for broadband chaotic noise," *Appl. Soft Comput.*, vol. 15, pp. 80–87, Feb. 2014.
- [27] Y. Zhou, Q. Zhang, and Y. Yin, "Active control of impulsive noise with symmetric α -stable distribution based on an improved step-size normalized adaptive algorithm," *Mech. Syst. Signal Process.*, vols. 56–57, pp. 320–339, May 2015.



FARKHANDA AFZAL received the Ph.D. degree from Beihang University, Beijing, China. She was with Beihang University; Bahria University, Islamabad; the KRL College Kahuta; and the University of Education Lahore. She is currently an Assistant Professor with the Department of Humanities and Basic Sciences, Military College of Signals (MCS), National University of Sciences and Technology (NUST), Islamabad, Pakistan. She has published numerous research papers in world-reputed journals and various national and international conferences. She has been invited speaker in several countries.



AYESHA ZEB received the degree from International Islamic University, Islamabad, in 2014, and the M.S. degree in electrical engineering (specializing in DSP and communications) from the College of Electrical and Mechanical Engineering, National University of Sciences and Technology (NUST), in 2016. She is currently a Lecturer with the College of Electrical and Mechanical Engineering, NUST. She is also an Electronics Engineer.



ABDUL WAKEEL received the Ph.D. degree from Jacobs University, Bremen, Germany, in 2016. In 2016, he joined the National University of Sciences and Technology (NUST), where he is currently an Assistant Professor. His research interests include PAPR reduction for OFDM-based SISO/MIMO systems, error control coding, signal processing, active noise control, physical layer security, and wireless communications.



WAQAR SHAHID QURESHI received the master's degree in computer engineering. He began his professional journey as an Electronic Engineer with a public-sector aerospace manufacturing company. He specializes in electrical engineering, particularly in signal and image processing. With two decades of experience, he has worked in both academic and industrial research and development roles, collaborating with local and international organizations and institutions. While currently on sabbatical from the position as a full-time Faculty Member with the National University of Sciences and Technology, he is currently a Marie Curie Career-Fit Fellow with Technological University Dublin, Ireland. His research interests include noise reduction techniques, the automated analysis of visual cues, and the application of artificial intelligence algorithms.



ALINA MIRZA received the Ph.D. degree in electrical engineering from the National University of Sciences and Technology (NUST), Islamabad, Pakistan, in 2016. Her research interests include communications systems, digital signal processing, and active noise control.



ALI AKGUL is currently a Full Professor with the Faculty of Arts and Science, Department of Mathematics, Siirt University. He is also the Head of the Department of Mathematics. He made a big contribution to fractional calculus and numerical methods. He has more than 250 research articles in outstanding journals. He has given many talks as an invited speaker at many international conferences.

...

Open Access funding provided by 'IREL Consortium' within the CRUI CARE Agreement