

## TOPICAL REVIEW

# Advancements, Challenges, and Prospects of Water-Filled Antennas

ABU SADAT MD. SAYEM<sup>1,2</sup>, ALI LALBAKSH<sup>1,2</sup>, (Senior Member, IEEE),  
KARU P. ESSELLE<sup>2</sup>, (Fellow, IEEE), GHOLAMHOSEIN MOLOUDIAN<sup>3</sup>, (Member, IEEE),  
JOHN L. BUCKLEY<sup>3</sup>, (Member, IEEE), AND ROY B. V. B. SIMORANGKIR<sup>3</sup>, (Member, IEEE)

<sup>1</sup>School of Engineering, Macquarie University, Sydney, NSW 2109, Australia

<sup>2</sup>School of Electrical and Data Engineering, University of Technology Sydney, Ultimo, NSW 2007, Australia

<sup>3</sup>Tyndall National Institute, University College Cork, Cork, T12RSCP Ireland

Corresponding authors: Gholamhosein Moloudian (gh.moloudian@tyndall.ie) and Ali Lalbakhsh (ali.lalbakhsh@mq.edu.au)

**ABSTRACT** In the group of liquid antennas, water antennas have attracted tremendous popularity due to the excellent electrical and mechanical properties of water. Pure water is a high permittivity dielectric liquid which comprises high dielectric constant and very low electrical conductivity. While the electrical conductivity of pure water is very low, salt-water has good electrical conductivity. The electrical conductivity of salt-water can be controlled by adjusting the ratio of salt content (salinity) in the water solution. Both pure water and salt water has excellent optical transparency, liquidity, flexibility and easy availability, thus, become excellent candidates in antenna manufacturing. Pure water is utilized as the dielectric component of the antenna and generally used in the development of dielectric resonator antennas, whereas salt-water is used as the conductive part of the antenna replacing metallic conductors. Some antennas have also utilized both the pure water and salt water for improved performance. In the literature, different classes of antennas can be found that have been developed by utilizing water. In this review paper, we have highlighted the state-of-the-art designs of water-filled antennas, highlighted the major challenges towards the development of water-filled antennas and presented the novel applications and prospects of water-filled antennas.

**INDEX TERMS** Antenna, conformal, liquid, reconfigurable, transparent, water.

## I. INTRODUCTION

In wireless communications, antennas play the most vital role in signal transmission, reception and overall network performance. In traditional radio communications, antennas are made with copper and rigid dielectrics, but over time, the applications of antennas have been spreading in new and diverse platforms, such as wearable technologies, tracking and navigations, surveillance, energy harvesting, smart cities, vehicular communications, sports etc. With booming demand, a lot of different types of antennas have been developed by the researchers. The properties of these antennas are significantly different from the conventional antennas made from copper and conventional dielectrics. For example, flexibility, stretchability, transparency, and reconfigurability

The associate editor coordinating the review of this manuscript and approving it for publication was Giorgio Montisci<sup>1</sup>.

are not common in conventional antennas. Apparently, these new antennas are developed from unconventional materials. Mostly used unconventional materials for antenna fabrication include textiles [1], polymers [2], papers [3], graphene [4], carbon nanotubes [5], conductive oxides [6], [7], [8] and conductive inks [9]. Apart from these materials, liquid metals, such as gallium [10], eutectic gallium indium (EGaIn) liquid metal alloy [11], [12], [13], gallium indium tin (GaInSn) liquid metal alloy [14], and liquid dielectrics, such as water [15] have attracted significant attention in recent years.

Liquid materials have some special features which make them unique in flexible and reconfigurable antenna manufacturing. Liquid materials are filled inside other elastic materials to achieve flexible/stretchable antennas. Liquid materials enclosed inside elastic materials follow the shape of the enclosing materials, this easy deformable characteristic is

utilized to design mechanically reconfigurable antennas [16]. Moreover, liquid materials enclosed by either elastic or rigid materials can be easily pumped-in or pumped-out which also offer a great opportunity in realizing mechanically reconfigurable antennas. For example, the liquid materials antennas [10], [11], [12], [13], [14] as mentioned in the previous paragraph are reconfigurable. Among liquid materials, water is the most prominent for antenna realization because water is multiple times less costly than liquid metals and water is free from chemical reaction with other materials which is highly beneficial in electronic devices. Water is optically transparent, easily available, inexpensive, non-toxic, easily transportable and easily processable. Pure water is a dielectric liquid having high dielectric constant and very low electrical conductivity [17]. By mixing salt with water, the electrical conductivity of water can be significantly increased and the salt mixed water becomes a good conductor. Due to these promising features, water is becoming a popular material for unconventional antenna realization.

In literature, a considerable amount of research approaches can be found on water-based antennas. Depending on the type of water used in antenna fabrication, antennas can be classified as pure water antennas, salt-water or sea-water antennas and hybrid antennas. Pure water-based antennas use pure water or distilled water as the dielectric components of the antenna. The dielectric constant of pure water is very high (nearly 80) [18], this high dielectric constant is utilized in the radiation mechanism of the antenna. Generally dielectric resonator antennas (DRAs) [19], [20], [21] are designed with pure water. DRAs have some remarkable characteristics, such as high bandwidth, good efficiency and compact size [22], on top of these properties, water based DRAs can offer the additional benefits of optical transparency, flexibility and cost-efficient fabrication. In contrast to traditional DRAs, a new type of pure water based antenna known as dense dielectric patch antenna (DDPA) was developed in [23] which operated more likely as a patch antenna instead of DRA. Section III of this paper highlights the research instigations on pure water-based antennas.

The electrical conductivity of water significantly increases when salt is diffused with it. The electrical conductivity of salt water is proportional to its salt content, and the saturated salt water can achieve a conductivity of nearly 20 S/m [24]. Salt mixed water is used as a replacement of metallic components of the antennas. Most of the antennas designed with salt-water are monopole type antennas [15], [25], [26]. However, other types of antennas are also developed with salt water, Section IV of this paper summarizes the works on salt water based antennas.

Whereas, majority of water-filled antennas are developed with either pure water or salt water, research approaches are also available which utilized both pure and salt water for improved performance. One such approach is [27] where a highly efficient wideband hybrid monopole antenna was designed using both pure water and salt water in a coaxial

dual-tube topology. Some notable research approaches on hybrid water antennas are demonstrated in Section V of this paper.

Water is an ideal material for designing reconfigurable antennas because of its liquidity. Different types of reconfigurable antennas, such as frequency reconfigurable, pattern reconfigurable and polarization reconfigurable antennas have been developed utilizing water. In [28], a pattern reconfigurable antenna was designed using water grating as a reflector. A polarization-reconfigurable circularly polarized spiral antenna designed with pure water was reported in [29]. A reconfigurable leaky-wave antenna utilizing periodic water grating was reported in [30]. Section VI highlights some successful research explorations of reconfigurable antennas developed with water.

Water has also been utilized for the development of flexible and optically transparent antennas. In [31], a flexible and transparent wearable antenna was developed by using pure water enclosed inside transparent and flexible cavity made with polydimethylsiloxane (PDMS). In another research approach in [32], a frequency reconfigurable flexible and transparent wearable antenna was developed by using pure water. This antenna utilized varactor diode for continuous frequency tuning. Section VII discusses the development of transparent antennas and flexible antennas from water.

It is apparent that water is becoming a popular material for unconventional antenna manufacturing. Different types of antennas with excellent characteristics have been developed with water. Water incorporates some potential benefits over other liquid materials which make it attractive for antenna realization. At the initial stage of the development of water antennas, the major advantages were associated with the attractive physical properties of water (low-cost, easy accessibility, transparency and non-toxicity) rather than the electromagnetic performance of the realized antennas. Most of the water antennas were suffered from low-bandwidth and poor radiation efficiency. However, in recent years, significant research investigations can be witnessed which have explored the performance improvement techniques of water-filled antennas. A considerable amount of works can be found in the literature since the development of first water antenna, but there is no comprehensive review article that has summarized the state-of-the-art research approaches on water-based antennas and discussed its characteristics under different environmental scenarios. Other review articles on liquid antennas, such as [33] and [34] have not solely focussed on the development of water antennas. For example, the review article demonstrated in [33] only highlighted the development of reconfigurable liquid antennas, the review article demonstrated in [34] summarized the research instigations on all types of liquid antennas including water, but many new works on different types of water antennas were not included there. So, a new comprehensive review article summarizing all the novel works on water antennas are highly essential. This review paper intends to fill this research

gap. The major objective of our paper is to demonstrate the electromagnetic properties of water, highlight the advantages of water in antenna manufacturing, challenges towards the development of water based antennas, recent progress in water antenna development and the applications and prospects of water antennas. This review article can attract significant interests from researchers in diverse backgrounds who work on unconventional materials based electromagnetic devices.

## II. CHALLENGES TOWARDS THE DEVELOPMENT OF WATER-FILLED ANTENNAS

It is evident that water offers numerous opportunities in developing flexible, stretchable, reconfigurable and low-cost antennas. Water is available almost everywhere, it is optically transparent, non-toxic, safe to handle, has high dielectric constant, inexpensive and easily processable and easily deformable. However, there are some significant challenges towards the development of antennas with water. Both pure water and salt water are utilized in antenna manufacturing. Pure water is a dielectric having high dielectric constant and low electrical conductivity. Pure water is used as a dielectric in the antennas, most of the antennas developed from pure water are dielectric resonator antennas where water enclosed inside holders are placed on top of metallic ground planes. In some antennas, the high dielectric constant of water is utilized to create a boundary condition for the incident electric fields and the water layer acts as an electric wall, which reflects electromagnetic waves, like metallic sheets. These antennas are named as dense dielectric patch antennas [23], [35] where metallic patches are replaced by water patches. However, either used in designing dielectric resonator antennas or dense dielectric patch antennas, pure water has high dielectric loss which degrades antenna efficiency. Figure 1 exhibits the dielectric properties of water at different temperatures at the frequency range 1-1000 GHz [18]. It can be seen that the dielectric loss of water is high. Moreover, the dielectric properties of water are dependent on frequency and highly sensitive to temperature variations. These shortcomings limit the applicability of water antennas in many real-life applications where antennas are exposed to frequently variable temperatures, where high radiation efficiency is required, and in millimetre-wave applications. So, designers should take these factors into consideration while designing water antennas and appropriately optimize the antenna design to keep the overall losses minimum. One of the notable approaches of reducing the losses of the dielectric resonator water antennas is to use low loss and low permittivity thin substrate between the water tube and the ground plane, which decreases the overall dielectric loss of the antenna and improves the efficiency.

Like pure water, salt water also poses its own limitations in antenna design. Salt water contains high concentration of salt and poses good electrical conductivity, the conductivity of the water is proportional to its salt content. Although salt water is a good conductor, it is considered as an imperfect conductor whose electrical conductivity is certain degree lower than

traditional metallic conductors (i.e., copper or silver) and when used in antennas as the radiating element, it suffers from high conduction losses which leads poor antenna efficiency.

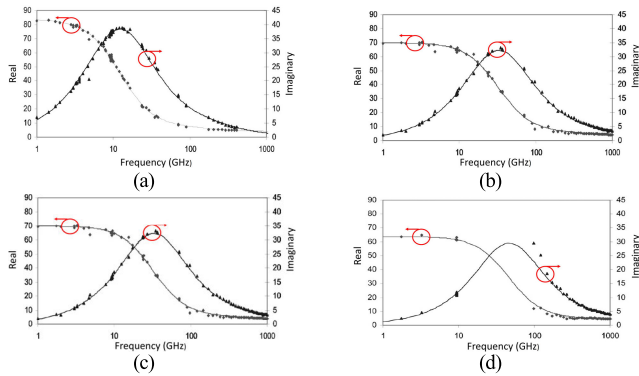
As water is a liquid, it needs a container to hold. The mostly used materials for manufacturing the containers are acrylic plastic, glass, Polyvinyl Chloride (PVC) and resin. The properties of the container materials are crucially important for proper antenna operation. The materials of the container should be robust to avoid any possible leakage, especially in designing mechanically reconfigurable antennas where the container frequently undergoes structural deformations. The container should be sealed properly to avoid possible short circuit and water evaporation. The materials of the containers should be selected properly because their properties can have serious impacts on the antenna performance. Moreover, bulky and heavy containers can increase the sizes and weights of the antennas which should be avoided in small circuit applications. While designing transparent antennas with water, the containers also need to be transparent, it imposes additional challenges to the fabrication of transparent containers while maintaining robustness and lightweight. Another notable challenge of water antennas is the high freezing temperature of water; water freezes just below 0°C, it apparently creates problem in very cold places and satellite applications. Moreover, the electrical properties of water vary with the variation of temperature and humidity, it is a significant shortcoming of water-filled antennas because with the change of electric properties of water, antenna characteristics also shift which may jeopardize the design goal. To minimize the environment impacts, sometimes additional chemicals such as propylene glycol need to be mixed with water and antenna characteristics need to be adjusted.

Like other liquid antennas, feeding the input electromagnetic waves to the antenna is a major challenge. For proper antenna operations, robust connection between the connector and antenna input terminal are highly essential. But, this is highly challenging in water based antennas because direct connection to water is not possible which limits the selection of the feeding mechanisms. Maintaining robust connection is also quite challenging especially in reconfigurable water-based antenna designs.

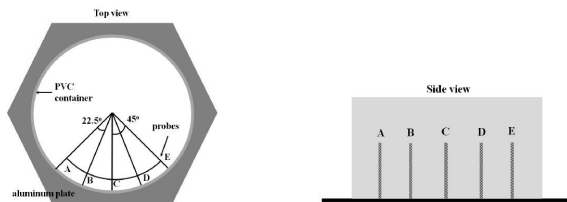
In spite of having the aforementioned challenges, water has been successfully utilized for antenna realization in a variety of applications. Researchers have successfully developed wideband water antennas, efficient water antennas, water antennas having compact size, flexible water antennas and dynamic water antennas.

## III. PURE WATER ANTENNAS

As found in the literature, pure water was first used in antenna realization in 1999 [36]. This first water antenna was a cylindrical multi-probe dielectric resonator antenna designed with pure water. The antenna structure consisted of a water-filled cylindrical tube made with plastic, the water-filled plastic tube was assembled on an octagonal-shaped ground plane (800 mm across the flat edges). The tube had a diameter of



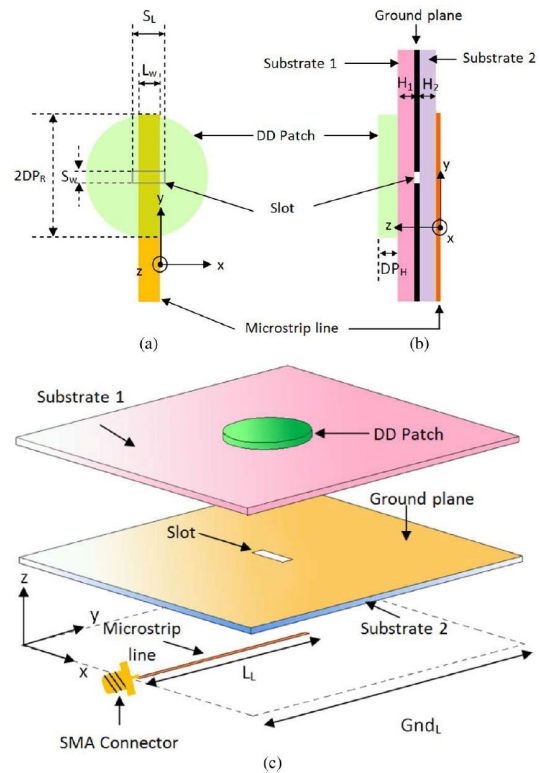
**FIGURE 1.** Dielectric constant (real part in the left axis and imaginary part in the right axis) of water at different temperatures-(a) 10° C, (b) 30° C, (c) 50° C and 70° C.(Reproduced from [18] with permission. Copyright © 2007 AIP Publishing LLC).



**FIGURE 2.** Structure of the first reported water-filled multi-probe cylindrical DRA. (Reproduced from [36] with permission. Copyright ©1999 IEE).

550 mm and a height of 200 mm. Figure 2 shows the structure of this first water antenna.

Since the development of first water-filled antenna, a number of different types of antennas have been developed with pure water. Although most of the pure water based antennas are dielectric resonator antennas, other types of antennas are also realized using pure water, including dense dielectric patch antenna using either metallic ground plane [37] or water based ground plane [35], short backfire antenna [38] and horn antenna [39]. Since the development of first water antenna, remarkable advancements can be witnessed in this highly demanding field. In the last few years, successful research investigations have been demonstrated to improve the radiation characteristics of the water antennas, make the size of the antennas small, realize circularly polarized antennas, develop improved feeding mechanisms or make reconfigurable antennas using water. For example, a rectangular compact dielectric resonator antenna designed with pure water was studied in [20]. In [40], an electrically small hemispherical shape dielectric resonator antenna utilizing pure water was developed. The overall size of the reported antenna was only  $\lambda/18$ . By using pure water, three new types of antennas were realized in [41], these antennas were Vee antenna consisting of two tilted pure-water rods, a normal-mode helix antenna producing circular polarization, and an array of titled pure-water monopoles generating omni-directional circular polarization. A wideband circularly polarized (CP) patch antenna using pure water in the patch and ground plane was realized in [42]. The water patch was square in shape incorporating two diagonal truncated corners for gener-

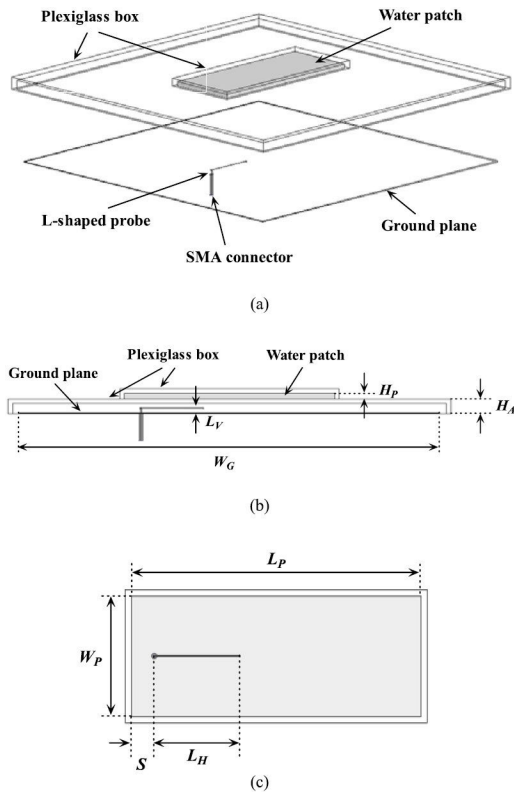


**FIGURE 3.** Structure of the dense dielectric patch antenna developed in [37]. (a) Top view. (b) Side view. (c) Perspective view. (Reproduced from [37] with permission. Copyright ©2013 IEEE).

ating CP radiation. The antenna was fed through an L-shaped metallic probe for achieving wide impedance bandwidth. The antenna achieved an impedance bandwidth of 29%, a 3 dB axial-ratio (AR) bandwidth of 8.0%, and a maximum radiation efficiency of 48%. This section briefly highlights some recent notable research approaches towards the development of pure water based antennas.

By using pure water, a new type of patch antenna was developed in [37] which was named as dense dielectric patch antenna (DDPA). In this antenna, the metallic patch was replaced by a high permittivity thin dielectric (water) slab called dense dielectric (DD) patch. The reported antenna topology is shown in Figure 3. This newly developed antenna topology consisted of a circular-shaped DD patch having a radius of 12.5 mm, which was placed on top of the dielectric substrate. The substrate was built with two layers of different materials both had the dielectric constant of 2.94. The substrate was square in shape having a length of 100 mm and thickness of 0.762 mm, which was located on a double sided PCB, the top surface had a slotted ground plane and a 50-Ω microstrip line was printed on the bottom surface. The microstrip line had an open ended quarter wavelength stub extended from the edge of the slot. Input signal was fed through the other end of the microstrip line by an SMA connector. From the operation of the antenna, it was revealed that fundamental  $TM_{11}$  cavity mode was excited in the space between the circular dielectric patch and the metallic ground plane, which looked like the excitation of a circular microstrip

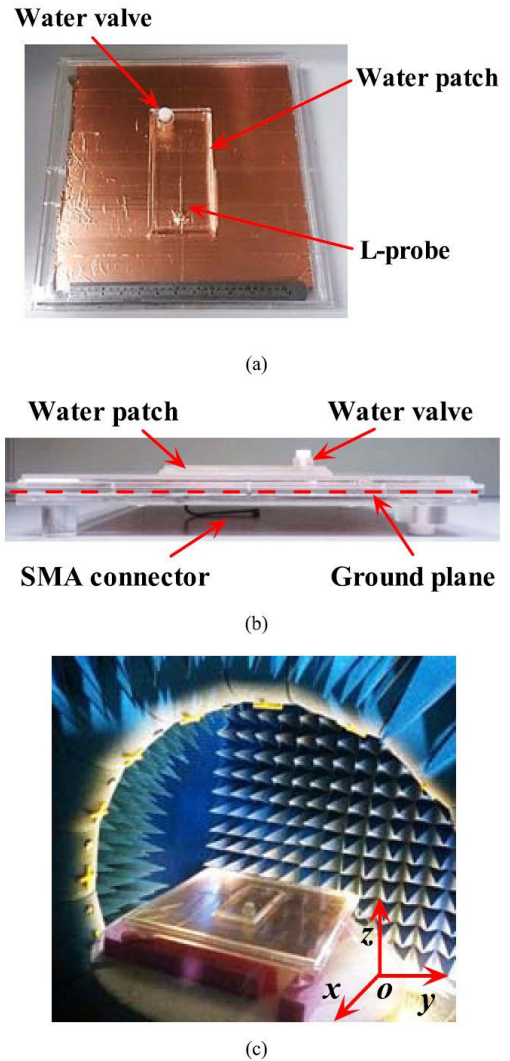




**FIGURE 4.** Geometry of the L-probe fed wideband water dielectric patch antenna developed in [23]. (a) Perspective view, (b) Side view, (c) Top view of the water patch with L-probe. (Reproduced from [23] under a Creative Commons Attribution 4.0 International License (CC BY 4.0)).

patch antenna. So, the antenna operated as a patch antenna rather than a DRA. In contrast to the conventional patch antennas, here the metallic patch was replaced by the high-permittivity dielectric patch, which is advantageous for millimeter wave applications. In millimeter-wave frequencies, conduction losses of metals contribute to the severe efficiency degradation of the antennas. If the metallic patches are replaced by this type of dielectric patch then the losses can be avoided and efficiency degradation can be minimized. The explored DD patch antenna in [37] was operated at 3.98 GHz frequency having an impedance bandwidth of 1% and a gain of 5.6 dBi. The gain was 0.5 to 1 dB higher than the conventional rigid DRAs. The reported efficiency of the antenna was 95% at 3.95 GHz.

In 2015, another water dense dielectric patch antenna (DDPA) was reported in [23]. The geometry of the antenna is illustrated in Figure 4. This antenna consisted of a rectangular box made with plexiglass to hold the water, this section acted as the dielectric patch of the antenna. Another larger hollow rectangular plexiglass box was placed underneath the patch, which acted as the support for the patch. This hollow box was supported by a metallic ground plane. As the supporting box was hollow, the medium between the patch and ground plane was air which acted as the low-loss substrate of the antenna. The antenna was fed through an L-shaped probe which is a popular connection mechanism



**FIGURE 5.** Photographs of the fabricated water dielectric patch antenna developed in [23]. (a) Structure, (b) Side view, (c) Antenna under test. (Reproduced from [23] under a Creative Commons Attribution 4.0 International License (CC BY 4.0)).

for wideband metallic patch antennas. In this design, the L-probe feeding incorporated the ease of fabrication because it avoided the need for physical connection to the water patch. The prototype of the water patch antenna is shown in Figure 5. From the numerical investigations of the antenna, it was found that water functioned as an electric wall and  $TM_{10}$  cavity mode was excited between the water patch and metallic ground plane. The antenna produced unidirectional patterns, like patch antenna and achieved low back-lobe and low cross polarization level. As the antenna was transparent, it was integrated with six-cell solar panel as shown in Figure 6 and achieved excellent performance with the solar cell. The bandwidth, gain and radiation efficiency of this water patch antenna alone were 8.02%, 7.34 dBi, and 60%, respectively; with solar cell, these values were 7.6%, 6.7 dBi and 53%, respectively. When operated with solar cells, the radiation efficiency was slightly compromised due to the associated dielectric loss of the silicon substrate, but the bandwidth and

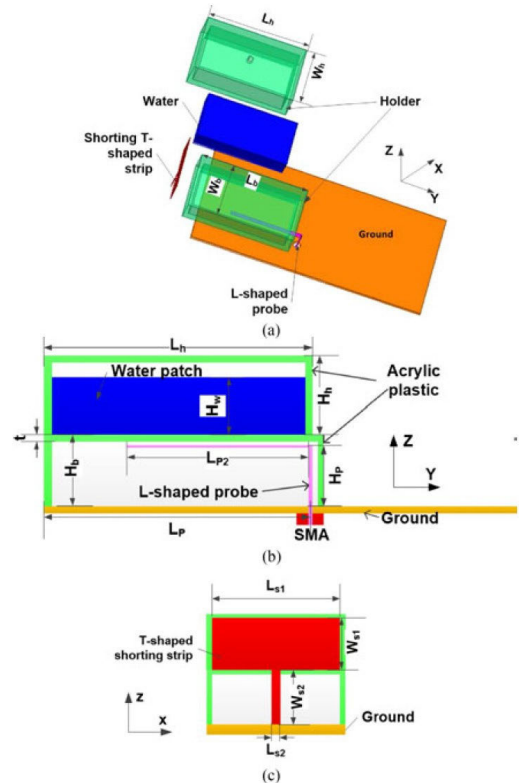


**FIGURE 6.** Prototype of the water dielectric patch antenna integrated with solar cells. (Reproduced from [23] under a Creative Commons Attribution 4.0 International License (CC BY 4.0)).

gain were not significantly degraded. It was suggested that the bandwidth could be improved by tuning the position of the L-probe. Because of its excellent features, the antenna was demonstrated as an excellent candidate for transparent wireless device.

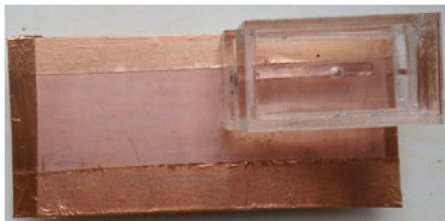
Until 2017, the reported water-based patch antennas utilized metallic ground planes which jeopardized the overall optical transparency of the antenna. In 2017, a new type of water patch antenna was developed by Sun and Luk [35], which used pure water in both the patch and ground plane. The water was held inside transparent plexiglass made circular container, which had a dielectric constant of 2.7 and dielectric loss tangent of 0.008. Plexiglass was selected because of its optical transparency and this glass can be cut into thinner sheets than other glasses, thus, it would not make the antenna bulky and heavy. The important feature of the developed antenna was its excellent transparency. The antenna topology comprised of three main parts, i.e., the water made patch, the water made ground plane, and the disk-loaded feeding probe. Air acts as the dielectric medium between the patch and ground. From the numerical analysis of the antenna, it was revealed that most of the electric field excited by the disk loaded probe were confined between the water patch and ground which was caused due to the high dielectric contrast between the water and air. Compared to the space between the water patch and ground, negligible electric field existed in the patch and ground itself, demonstrating that the antenna worked in patch mode rather than working in the dielectric resonant mode. The antenna showed excellent electromagnetic performance having wide-band omnidirectional conical beam radiation pattern with small cross-polarization level. The antenna achieved 35% impedance bandwidth from 2 to 2.85 GHz, the realized gain was varied between 1.5 to 4 dBi in this frequency band and the radiation efficiency was varied from 57% to 82%.

A modified dense dielectric patch antenna utilizing pure water was investigated in [43]. In this water DDPA, the dielectric loss of water had less impact on the radiation efficiency of the antenna, thus, the antenna became an efficient radiator.



**FIGURE 7.** Geometry of the compact water patch antenna developed in [43]. (a) Exported view. (b) Side view. (c) Left view. (Reproduced from [43] with permission. Copyright ©2017 IEEE).

Moreover, the antenna was compact in size and incorporated wide bandwidth. The configuration of this compact water DDPA is depicted in Figure 7. The antenna comprised of two acrylic plastic boxes located above a ground plane. The bottom box occupied larger space than the upper box, which was used as the support for the upper one. The top box was used to hold the water. In this design, air acted as the dielectric medium between the water patch and the ground plane. The bottom acrylic plastic holder acted as the low-loss and low-permittivity supporting substrate and reduced the overall dielectric loss of the antenna. Moreover, the antenna was excited in cavity mode which lessened the effect of the dielectric loss of the water on the antenna efficiency. A T-shaped shorting metal patch was incorporated to the left walls of the holders, which subsequently reduced the resonant frequency of the water patch and miniaturized the size of the antenna. The antenna occupied a dimension of  $0.146 \lambda \times 0.078 \lambda \times 0.063 \lambda$  which was quite smaller than other water antennas. The coupling L-shape probe enhanced the bandwidth of the antenna. The antenna achieved 6-dB return loss bandwidth of 510 MHz (690-1200 MHz). The antenna had a gain of 2 dBi and achieved a radiation efficiency of 70%. Figure 8 illustrates the prototype of the new compact highly efficient water DDPA. It can be seen that the antenna is optically transparent because of the transparency of water and the use of transparent plastic holder. Due to its transparency, compactness and excellent electromagnetic performance, the antenna

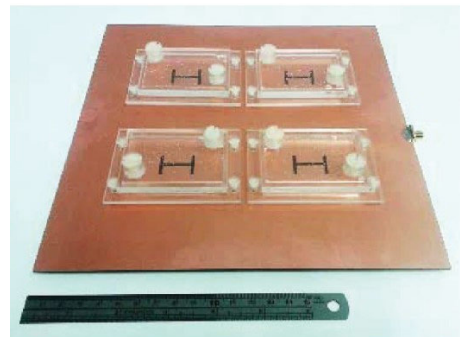


**FIGURE 8.** Prototype of the compact water patch antenna developed in [43]. (Reproduced from [43] with permission. Copyright ©2017 IEEE).

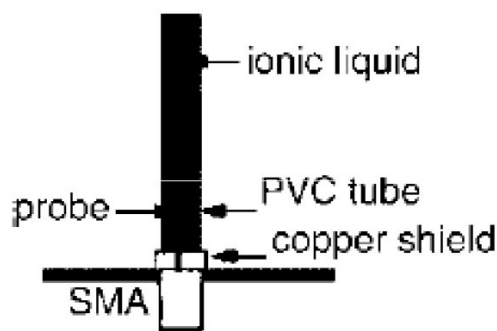
was an efficient candidate for high efficiency compact circuit applications.

Array antenna with water dielectric patch is also reported in the literature [44]. Reference [44] developed a  $2 \times 2$  water dielectric patch antenna array for Wi-Fi network. Figure 9 exhibits the prototype of the water dielectric patch antenna array. In this design, pure water layer was used as the dielectric patch which replaced the copper patch of the traditional microstrip antennas. The array was fed through an H-shaped slots. The array achieved a 10-dB impedance bandwidth of 420 MHz (2.23 to 2.65 GHz) and a maximum gain of 12.8 dBi.

It is explicit that significant research progress has been made on antennas designed with pure water. The operation of these antennas is based on the high dielectric constant of pure water. Initially almost all of the developed antennas from pure water were dielectric resonator antennas (DRAs) where pure water was used as the dielectric resonator. In most of these designs, water was hold by transparent glass or plastic materials to make the antennas transparent. The liquidity and optical transparency of pure water were the most attractive features of these water based DRAs. After successful applications of water DRAs, new types of DRA known as dense dielectric patch antenna (DDPA) was developed where metallic patch was replaced by water based dielectric patch. The working principle of this DDPA was similar to a patch antenna rather than DRA. The initial design of the DDPA used metallic ground plane, but later the metallic ground was replaced by water based dielectric ground plane which made the antenna geometry entirely transparent. DDPA can offer promising performance in millimeter wave applications; in millimeter wave bands, the metallic loss of the patches is significantly high which degrades antenna efficiency, by replacing the metallic patches with dielectric patches, this metallic loss can be avoided. Moreover, the transparent DDPA can be unobtrusively integrated on the existing infrastructures and visually imperceptible communication network can be made. However, in spite of having some remarkable advantages, pure water has high dielectric loss which degrades antenna efficiency. Some recent research approaches developed new techniques to minimize the overall antenna losses, one of these techniques is using a low-loss and low-permittivity supporting substrate underneath the water resonator. Moreover, research investigations can be witnessed which have tried to enhance the bandwidth by modifying the feeding mechanism



**FIGURE 9.** Prototype of the water dielectric patch antenna array developed in [44]. (Reproduced from [44] with permission. Copyright © 2015 IEEE).

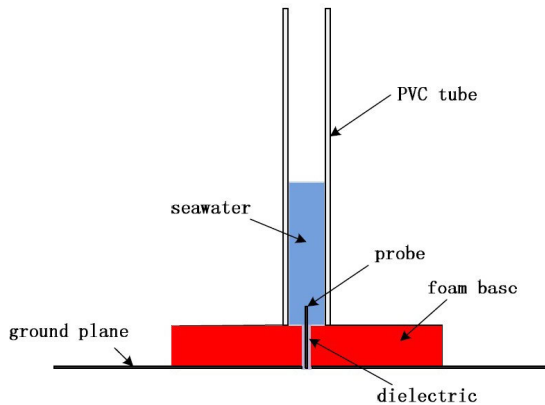


**FIGURE 10.** Structure of first reported salt-water monopole antenna. (Reproduced from [26] with permission. Copyright ©2006 The Institution of Engineering and Technology).

of the antenna. In addition, some research approaches developed compact DRA and DDPA. So, it is explicit that successful research explorations have been made on pure water based antennas which offer a lot of opportunities in a wide variety of applications.

#### IV. SEA WATER ANTENNAS

Sea water or salt water has good electrical conductivity, sea water is used as the conductor in antenna design. The conductivity of the sea water is proportional to its salt content, which impacts the performance of the antenna. Basically monopole antennas are designed with sea water [15], [25], [26], however, other types of antennas, such as half-loop antenna [45], fan-shaped antenna [46] have also been realized with sea water as reported in the literature. The first salt-water monopole antenna was reported in 2006 by Fayad and Record [26]. The reported antenna was a wideband monopole antenna. Figure 10 shows the geometry of this first salt water antenna. A vertical tube made from polyvinyl chloride (PVC) was mounted on a  $25 \times 25 \text{ cm}^2$  ground plane. The tube was filled with sea water. The performance of this water monopole antenna was investigated with varying salt content (salinity) of the water, and it was found that bandwidth was increased with the increase of salt content. It was explained from the series resonant model of the monopole antenna that with the increase of the salinity of water, the equivalent radiation resistance of the antenna was decreased which degraded the



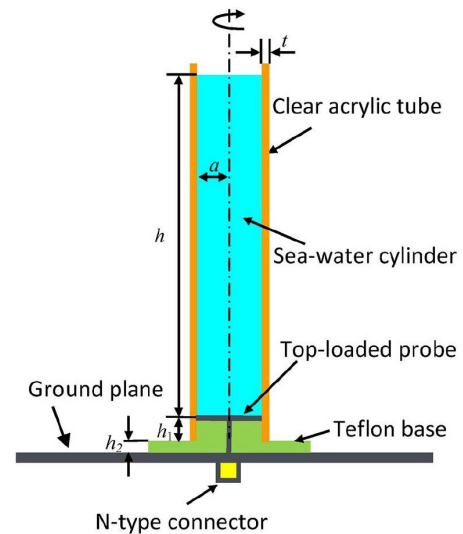
**FIGURE 11.** Geometry of the water monopole antenna. (Reproduced from [47] with permission. Copyright ©2012 IEEE).

performance. It was also explored that when the salinity was reached 6 ppt, the antenna stopped resonating.

Since the introduction of the first salt-water monopole antenna in [26], a number of water monopole antennas were developed with different feeding mechanisms, such as directly inserting a feeding probe into the water [26], loading the feeding probe with nut and washer [15], incorporating a dielectric base between the water and ground plane [47] and different approaches to improve the performance of the antenna.

The performance of a sea water monopole antenna for varying the properties of water was investigated in [47]. The embodiment of the antenna as sketched in Figure 11 consisted of a PVC (relative permittivity = 4) tube to hold the water, the tube was mounted on a ground plane, a foam layer was used to isolate the water from the ground plane. In this work, the impact of the conductivity of the water on the radiation efficiency of the antenna was studied. It was found that when the conductivity of water increased from  $10^{-6}$  to  $10^{-3}$  S/m, the efficiency of the antenna was dropped from nearly 100% to 80%, here the antenna functioned as high permittivity DRA. When the conductivity of water varied between  $10^{-3}$  S/m and  $10^2$  S/m, the antenna worked as a combination of dielectric resonator and conducting antennas, and the efficiency remained below 80%. When the conductivity of water exceeded  $10^2$  S/m, the water antenna acted like a conventional conducting antenna and the efficiency reached over 80%. The impact of the insulator material on the bandwidth and efficiency of the antenna was also investigated. Between the water tube and ground plane, three different insulator materials, i.e., Foam (relative permittivity 1), Teflon (relative permittivity 2.1) and Paxolin (relative permittivity 5.5) were used, and antenna bandwidth and efficiency were numerically investigated. It was found that foam base accomplished the widest 10-dB impedance bandwidth and highest efficiency. It was concluded from the study that low-permittivity and low-loss insulator underneath the water tube provided better bandwidth and radiation efficiency of the antenna.

An efficient sea-water monopole antenna operating at very high frequency (VHF) band for maritime wireless communi-

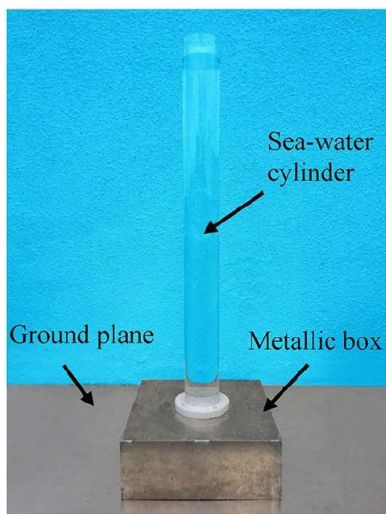


**FIGURE 12.** Geometry of the sea-water monopole antenna incorporating improved radiation efficiency. (Reproduced from [48] with permission. Copyright ©2014 IEEE).

cations was demonstrated in [48]. The demonstrated antenna achieved high radiation efficiency because of the utilization of efficient feeding structure and thick sea-water cylinder. The configuration of the antenna is depicted in Figure 12. This vertical sea-water monopole was assembled on a Teflon base and sealed with silicone gasket. The Teflon base was backed by a metallic ground plane. A clear acrylic tube was used to hold the water. Because of the transparency of the tube, the structure of the monopole antenna was optically transparent except the ground plane, Teflon base and the feeding probe. The feeding probe was loaded with an aluminum disk which improved the excitation of the TM mode of the monopole. To excite the desired TM mode, the acrylic tube and the feeding probe were concentrically mounted. It was found from the numerical analysis that the radiation efficiency of this water monopole antenna was increased gradually with the increase of the water cylinder's radius (as well as water radius) or the conductivity of the water which followed the theory that thinner water stream incorporated higher loss resistance and decreased the radiation efficiency [49]. The prototype of the sea-water monopole antenna is exhibited in Figure 13. The monopole antenna achieved an impedance bandwidth of 27.5% and the radiation efficiency varied between 50.2% and 72.3% over the observed frequency band of 40–200 MHz.

Another efficient sea-water monopole antenna was designed in [25]. This work was an advancement of the authors' previous work as described in [48]. The demonstrated feeding technique in [48] was only suitable for static-type water-filled monopole antennas. It can be noted that static-type water monopole antennas have some shortcomings in practical applications, especially in high frequency (HF) or ultra-high frequency (UHF) operations because in these frequencies, the water monopoles require very long tubes making the assembly process difficult and sometimes unrealistic.

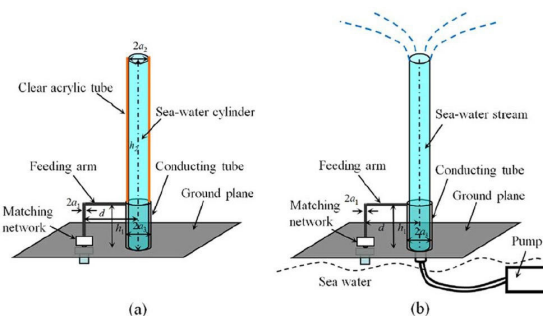




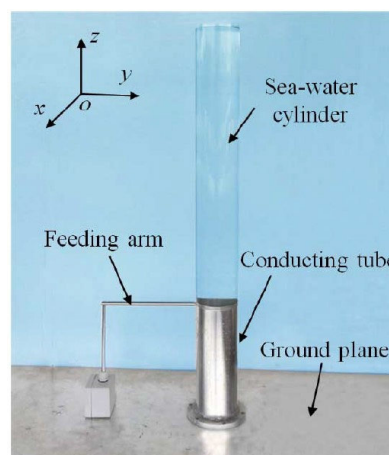
**FIGURE 13.** Photograph of the sea-water monopole antenna incorporating improved radiation efficiency. (Reproduced from [48] with permission. Copyright ©2014 IEEE).

Dynamic-type water monopole antennas are more realistic in real-life applications because they are fast in terms of reconfigurability and they do not require very long holder. In [25], a dynamic-type water monopole antenna was developed that incorporated a shunt-excited feeding method that was very efficient for feeding dynamic-type water monopole antennas. In the demonstrated work, both the static and dynamic-type water monopole antennas were developed with this feeding technique. Figure 14 exhibits the configurations of the shunt-excited water monopole antennas of static and dynamic type. The proposed feeding structure consisted of a conducting tube and a  $\Gamma$ -shape feeding arm connected to the conducting tube near the top. A matching network, protected in a waterproof plastic box, was inserted to the feeding arm at the bottom to maintain good impedance matching. The sea-water was hold by a transparent acrylic tube vertically mounted on the conducting tube. Figure 15 and Figure 16 illustrate the photograph of the static-type sea water monopole antenna and dynamic-type sea water monopole antenna, respectively. The dynamic type antenna was tested in a real sea-side environment. A thick sea-water stream was produced by pumping the sea water and jetted through the conducting tube, this water stream formed the monopole having a height of nearly 1 m. The large sea surface acted as the ground plane for the antenna. The dynamic type water monopole antenna achieved a radiation efficiency of 56.2% at 56.5 MHz.

A sea-water half-loop antenna operating at the VHF band was developed in [45] for maritime wireless communications. The geometry and prototype of the antenna are shown in Figure 17. As shown in Figure 17, the antenna was tested in real sea-side environment. The antenna was fed by a capacitively-couple feeding structure. The sea water half loop was formed by first pumping the sea-water into the metallic tube and then shot out the water stream from the tube. The explored antenna was easily reconfigurable and it could be turned off in real time, making it compatible for



**FIGURE 14.** Geometry of the shunt-excited sea-water monopole antennas developed in [25]. (a) Static-type. (b) Dynamic-type. (Reproduced from [25] with permission. Copyright ©2015 IEEE).



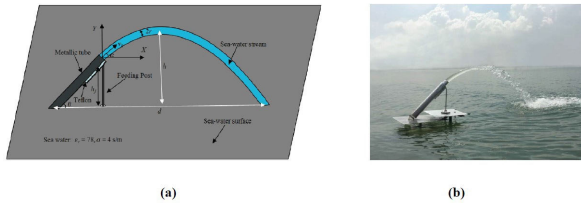
**FIGURE 15.** Photograph of the static-type sea-water monopole antenna developed in [25]. (Reproduced from [25] with permission. Copyright © 2015 IEEE).



**FIGURE 16.** Photograph of the dynamic-type sea-water monopole antenna operated in real sea-side environment. (Reproduced from [25] with permission. Copyright ©2015 IEEE).

maritime wireless communications. The antenna achieved an impedance bandwidth of 27%, a gain of 2.4 dBi and radiation efficiency of 35%.

Antennas developed with sea water have potential applications in maritime wireless communications, optically transparent electronic platforms, millimeter-wave communications and cost-efficient production of antennas. The electrical conductivity and liquidity of sea water offer



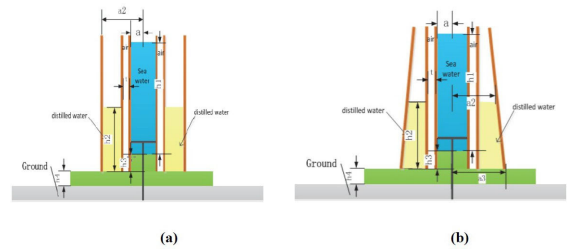
**FIGURE 17.** Sea-water half-loop antenna developed in [45]. (a) Antenna geometry. (b) Fabricated prototype operating in real sea-side environment. (Reproduced from [45] with permission. Copyright ©2015 IEEE).

promising characteristics in antenna manufacturing, such as low cost, optical transparency and easy handling. In the developed sea-water antennas, the conductive parts of the antennas are realized with sea-water. Most of the sea-water antennas are monopole type antennas where the basic antenna topology comprised of a transparent water holder tube, a ground plane and an insulator located between the tube and ground plane. The performance of the antenna depends on the conductivity of the water, radius of the water monopole, the dielectric properties of the tube and the properties of insulating material. From the literature survey, it has been explored that higher conductivity of the sea water increases antenna efficiency, whereas the permittivity and loss-tangent of the insulator impact the bandwidth of the antenna, it has been found that low-permittivity dielectrics improve the bandwidth of the antenna. The radius of the water monopole has significant effect on the efficiency of the antenna, the efficiency increases with the increase of the radius of the water monopole. Designing an efficient feeding mechanism is one of the major concerns of sea water antennas. Many research investigations concentrated on designing the efficient feeding mechanism of the antenna. Probe feed is the most popular feeding method of sea water antennas. Some recent works have made some modifications to the probe-feeding method to improve the performance. For example, disk loaded feeding probe improves the efficiency of the antenna. Capacitively-couple feeding method is also an efficient feeding strategy for dynamic type sea water antenna. Researchers have also developed dynamic sea-water monopole antennas where the antennas operate in real sea-side environment and the monopoles are formed by pumping the water jet.

In-spite of having many promising features, sea water has poor electrical conductivity compared to the traditional metals, the poor conductivity degrades antenna efficiency. The efficiency of the antenna can be improved by utilizing high salt content water and higher radius water monopole; however, the transparency and size of the antenna should be concerning factors for these strategies. Another challenge of the sea water antennas is their large height in UHF bands.

**V. HYBRID WATER ANTENNAS**

It is conspicuous that water has been utilized in antenna manufacturing for versatile applications. As found in the literature, water used in antenna realization are either pure



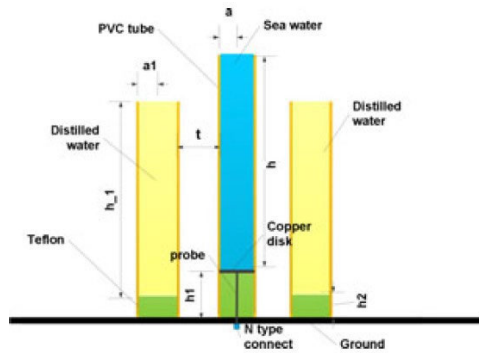
**FIGURE 18.** Geometry of the hybrid water antenna developed in [51]. (a) Monopole-ring antenna and (b) Monopole-conical antenna. (Reproduced from [51] with permission. Copyright ©2015 IEEE).

water or salt water. However, most of the antennas developed with either pure water or salt water suffer from narrow bandwidth and poor radiation efficiency. To improve the performance of water antennas, different techniques have been adopted by the researchers, such as loading the feeding probe with a disk to improve the excitation of the TM mode [48], loading of metal patches and metal rods to improve the efficiency [50], and combining the water monopole with dielectric resonators [51], [52], [53], [54].

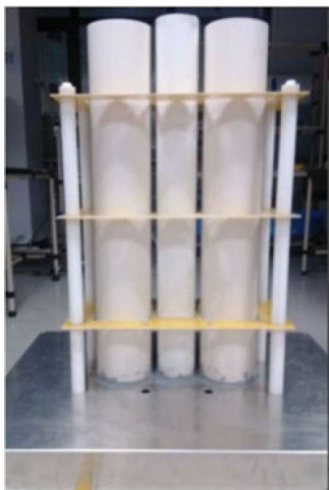
While maintaining the transparency and liquidity, the most effective technique of performance improvement of water antennas is to utilize both the pure water and salt water combining the conducting property of the sea water and the dielectric property of the distilled water to improve the performance of the antennas; these antennas are called hybrid water antennas. Different research approaches can be found in the literature that investigated hybrid water antennas for improved antenna performance.

Reference [51] investigated two hybrid water antennas as depicted in Figure 18. Figure 18(a) shows a hybrid water antenna operating at UHF band which consisted of sea-water monopole antenna and a distilled water ring antenna. This hybrid structure achieved an impedance bandwidth of 102% (52.5 to 162.5 MHz). Figure 18(b) depicts a hybrid structure consisting of a sea-water monopole antenna and a distilled water conical dielectric resonator antenna. This structure achieved 129% impedance bandwidth which was higher than the demonstrated hybrid structure in Figure 18(a).

In [26], salt was dissolved into pure water to modify its dielectric properties, a monopole antenna was designed with this water which achieved improved bandwidth (nearly 10% impedance bandwidth). A broadband hybrid water antenna implemented for hand-portable applications was demonstrated in [55]. In [47], a hybrid water monopole antenna was designed which achieved nearly 95% impedance bandwidth, however, the antenna occupied large radius which limited its applications in compact circuits. In a later research approach as demonstrated in [56], a hybrid water monopole antenna was developed which achieved 85% impedance bandwidth without occupying very large area. The configuration of the antenna is shown in Figure 19. Figure 20 illustrates the prototype of the hybrid water antenna. This hybrid water monopole antenna consisted of a vertical sea water monopole surrounded by two distilled water resonators, these monopole



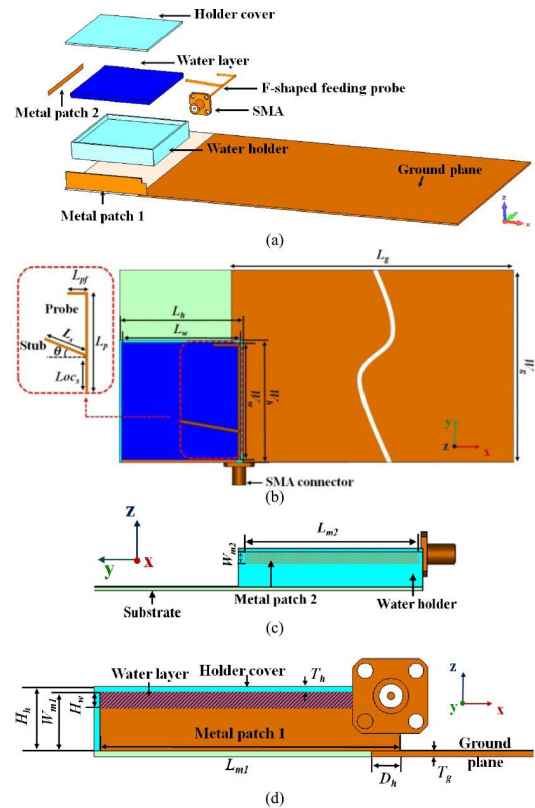
**FIGURE 19.** Geometry of the hybrid water monopole antenna developed in [56]. (Reproduced from [56] with permission. Copyright ©2017 IEEE).



**FIGURE 20.** Prototype of the hybrid water antenna developed in [56]. (Reproduced from [56] with permission. Copyright ©2017 IEEE).

and resonators were mounted on a common ground plane. The vertical cylindrical sea-water monopole was positioned on a Teflon-made base which provided isolation and protected from any possible short circuit. Sea-water was enclosed by polyvinyl chloride (PVC) (dielectric constant 2.7) tube. The resonances of sea water monopole and from pure water resonators were combined and the bandwidth was enhanced. From the analytical study, it was revealed that sea-water alone had two resonances at 71.5 and 187 MHz; but the hybrid structure had four resonance frequencies at 76, 115, 157, and 169 MHz. So, the hybrid water antenna achieved a wide impedance bandwidth of 85% (69 to 171 MHz), where 63% bandwidth improvement was achieved with hybrid structure as compared with the monopole alone. Radiation efficiency of the antenna was varied between 40% and 74% in the operating band.

A wideband hybrid water antenna was demonstrated in [57]. The configuration and prototype of the wideband hybrid water antenna is shown in Figure 21 and Figure 22, respectively. The antenna consisted of a rectangular water layer hold by an acrylic plastic container. An FR-4 substrate was used underneath the holder, the substrate was backed by a ground plane. An F-Shaped monopole was used as the feeding probe which enhanced the bandwidth. Two cop-



**FIGURE 21.** Configuration of the F-Shaped wideband hybrid monopole water antenna developed in [57]. (a) Exploded view. (b) XOY plane view (holder cover is hidden). (c) YOZ plane view. (d) XOZ plane view. (Reproduced from [57] under a Creative Commons Attribution 4.0 International License (CC BY 4.0)).

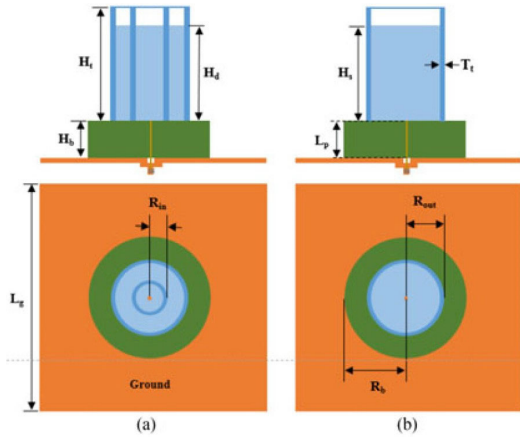


**FIGURE 22.** (a) Prototype of the F-Shaped wideband hybrid water monopole antenna developed in [57], (b) RC set-up for antenna efficiency measurement. (Reproduced from [57] under a Creative Commons Attribution 4.0 International License (CC BY 4.0)).

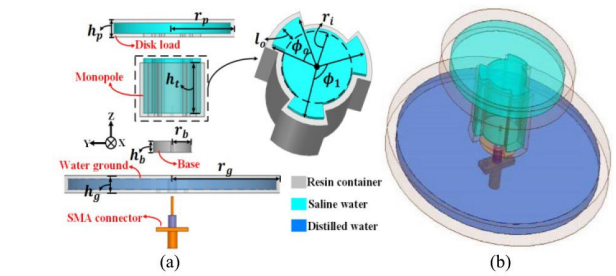
per patches were attached to the front and left side of the rectangular holder, the patch loading reduced the resonant frequency of the water DRA and, thus, minimized the size of the antenna. The antenna achieved an impedance bandwidth of 71.8% while maintaining low profile.

A co-axial dual-tube hybrid water antenna having improved efficiency and wide bandwidth was reported in [27]. In this paper, a single tube water monopole antenna was also studied to evaluate how the performance of the antenna was improved after incorporating hybrid structure. The configuration of the co-axial dual-tube hybrid water antenna along with single-tube water monopole antenna is shown in Figure 23. Two co-axial transparent cylindrical acrylic tubes were vertically installed on a cylindrical Teflon

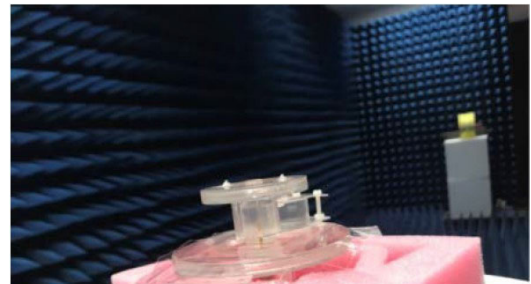




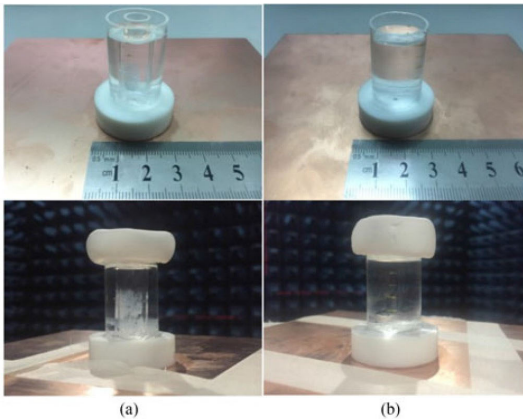
**FIGURE 23.** Geometry of the water monopole antenna developed in [27]. (a) Dual-tube monopole. (b) Single-tube monopole. (Reproduced from [27] with permission. Copyright ©2018 IEEE).



**FIGURE 25.** Fan-shaped compact water patch antenna developed in [46]-(a) Configuration and (b) Perspective view. (Reproduced from [46] with permission. Copyright ©2022 IEEE).



**FIGURE 26.** Photograph of fabricated fan-shaped compact water patch antenna inside the measurement chamber. (Reproduced from [46] with permission. Copyright ©2022 IEEE).



**FIGURE 24.** Photograph of the fabricated water monopole antenna developed in [27]. (a) Dual-tube monopole and (b) Single-tube monopole. (Reproduced from [27] with permission. Copyright ©2018 IEEE).

base backed by a ground plane. The bottom of the Teflon isolated the ground from the water. The inner and outer tubes were filled with dis- tilled water and salt water, respectively. A vertical feeding probe was used to excite the water monopole antenna. In this hybrid structure, multiple modes were excited from the water monopole and the distilled-water-loaded probe, which enhanced the bandwidth. Moreover, the hybrid structure im- proved the radiation efficiency of the antenna. As compared to the single tube monopole antenna, an improvement of the impedance bandwidth from 38.24% to 57.27% and an improvement of the radiation efficiency from 15% to 47% and 52% to 84% in the operating frequency range were witnessed for the dual-tube hybrid structure. Figure 24 shows the prototypes of the coaxial dual-tube hybrid water antenna along with the single-tube water antenna.

A compact wideband transparent water patch antenna employing both the pure water and salt water was developed in [46]. Figure 25 depicts the configuration and perspective view of this water patch antenna. The antenna accomplished a fan-shaped cylindrical radiator which was made with salt water, contained inside transparent resin container.

The radiator was loaded with a sea water top disk, the fan-shaped radiator and the loaded top disk jointly shortened the overall dimension of the antenna without affecting the impedance matching. A pure water reflector was used at the bottom of the antenna structure which acted as the ground plane, this water was also hold by transparent resin container. The antenna was fed through an SMA connector. The antenna achieved a wide impedance bandwidth of 82.5%, the measured radiation efficiency varied from 43% to 60% in the operating frequency band and achieved a maximum peak gain of 0.2 dBi. Figure 26 depicts the fabricated prototype of the compact transparent water patch antenna located inside the measurement chamber.

Utilizing both the pure water and sea water is a notable progress of water antennas. Combining the high dielectric properties of pure water and the electrical conductivity of sea water improves the radiation properties of the antennas. Hybrid water antennas comprise a variety of topologies, such as sea water monopole loaded by one or more pure water DRAs, mixing pure and sea water and form a monopole, designing dual-tube monopole where one tube is filled by sea water and another one with pure water, and pure water DRA backed by sea water ground. The radiation characteristics of the hybrid water antennas have improved performance because of the formation of multiple resonances from the pure and sea water resonators. However, the size of the hybrid water antennas is quite large. The recent research approaches have developed some innovative techniques to reduce the size of the antenna, these techniques include loading one or more metallic patches or disk to the antennas.



## VI. RECONFIGURABLE WATER ANTENNAS

Reconfigurable antennas can tune the operating frequency [58], radiation pattern [59], polarization [60], [61], direction of the main beam [62] and combinations of two or more of these properties [63]. Reconfigurable antennas have rising demands in wireless communications. Liquid metals and liquid dielectrics are prominent candidates in the realization of reconfigurable antennas. Water is a transparent liquid which has excellent conformality. The length, height, volume and shape of water can be easily modified and water can be easily drained out from the tube, thus, water becomes an excellent candidate for designing reconfigurable antennas. Different types of reconfigurable antennas have been developed by using water which have provided good tuning of operating frequency, radiation patterns and polarization.

A frequency reconfigurable DRA based on pure water was developed in [64]. In this cylindrical DRA, water level was varied from 95 mm to 276 mm and frequency was tuned from 96.8 MHz to 59 MHz. A folded monopole probe, with 3 varicap diodes, was employed as the feed of the DRA, this feeding technique maintained stable impedance matching for variable water level.

A water helix antenna having polarization-reconfigurability over a wide frequency band was demonstrated in [65].

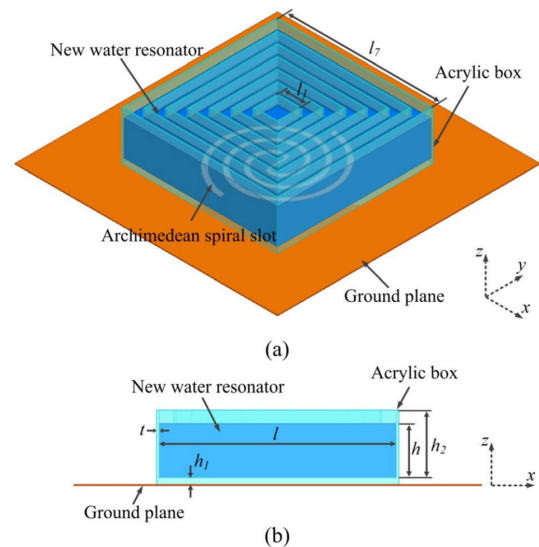
A wideband water patch antenna having polarization diversity was demonstrated in [66]. In this work, an adjustable circular shape plexiglass container was used to hold pure water, this was used as the patch of the antenna. The antenna used a metallic ground plane. The demonstrated antenna operated in three different polarization states, utilizing three different feeding port for each state.

A pattern reconfigurable monopole Yagi-Uda antenna using sea-water was developed in [67].

A sea water antenna having beam-steering capability was realized in [68]. This unique beam-steering antenna operated at 13 different working states accomplishing good radiation efficiency (60%), and gain (5.8 dB).

A reconfigurable short backfire antenna realized by pure water was demonstrated in [38]. By controlling the water flow in different layers of a cylindrical wave guide made with transparent resin, the antenna was tunable between two different functions. In function I, the antenna operated as a short backfire antenna with pencil beam, whereas, in function II, conical beam was produced from the antenna, the beam angle was tunable through controlling the height of water cylinder and water wall. In function I, the water short backfire antenna achieved an impedance bandwidth of 11.3% and a maximum gain of 10.8 dBi. In Function II, the beam angle of the conical radiation beam was steerable between 25° and 60°. In function II, the antenna achieved an impedance bandwidth of 5% and a maximum gain of 6.8 dBi for 25° beam direction and 2.7 dBi for 60° beam direction, respectively.

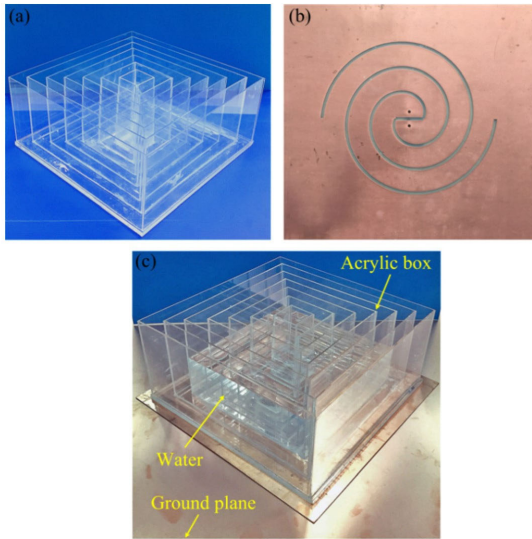
Reference [39] explored a novel high gain water horn antenna having pattern reconfigurability. The walls of this horn antenna were realized by using pure water instead of traditional metals, this is the unique feature of this demonstrated



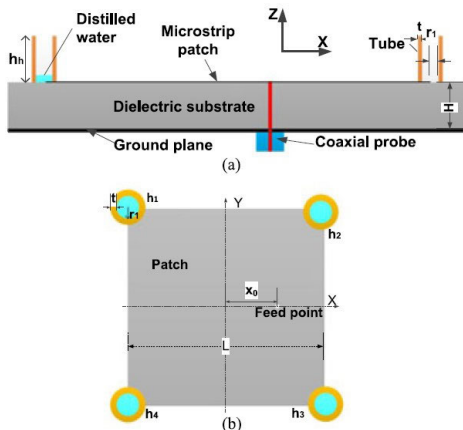
**FIGURE 27.** Structure of the CP frequency-reconfigurable water antenna developed in [24]. (a) 3D view. (b) Side view. (Reproduced from [24] with permission. Copyright ©2016 AIP Publishing LLC).

antenna. A 3-D printed transparent resin box containing interlayers were filled with pure water and acted as the walls of the horn just like metallic walls of traditional horn antennas. By controlling the water levels in these interlayers, this water horn antenna was switched between two states, such as H-plane horn state and leaky-wave state, producing two different radiation patterns. The demonstrated antenna achieved wide impedance bandwidth in two states (2.5 to 5.2 GHz in H-plane horn state and 2.6 to 5.7 GHz in the leaky-wave state), high gain (maximum realized gain of 11.8 dBi for the H-plane horn and 7.7 dBi for leaky-wave state) and more than 90% radiation efficiency.

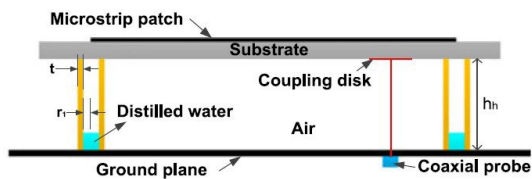
A circularly polarized (CP) wideband frequency reconfigurable pure water antenna having high radiation efficiency and stable radiation pattern was developed in [24]. This antenna achieved a continuous wide frequency tuning range from 155 MHz to 400 MHz exhibiting an average radiation efficiency of about 90% and good circular polarization in the tuning range. The configuration of the antenna is shown in Figure 27 and the prototype is shown in Figure 28. This design used an specially designed acrylic container containing 7 layers in the cross-section to hold the pure water which functioned as the dielectric resonator, this resonator was mounted on a conducting ground plane. The bottom layer of the acrylic container acted as the low-permittivity substrate between the ground plane and resonator. Incorporation of the low loss and low permittivity thin substrate decreased the effective loss tangent of the water resonator, thus, this water resonator antenna incorporated much lower dielectric loss than the traditional water resonator antennas, making it an efficient water antenna. Moreover, the acrylic container was specially designed so that water resonator's height and cross-sectional dimension were adjustable which lead to frequency tuning without affecting the near-field distributions and corresponding far-field radiation patterns of the resonant



**FIGURE 28.** Prototype of the CP frequency-reconfigurable water antenna developed in [24]. (a) The empty acrylic box. (b) The Archimedean spiral slot. (c) 3D view of the prototype antenna partially filled with water. (Reproduced from [24] with permission. Copyright ©2016 AIP Publishing LLC).



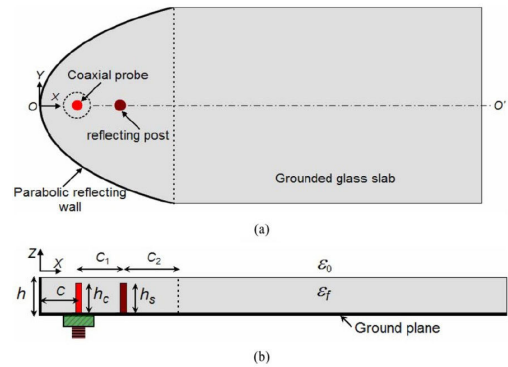
**FIGURE 29.** Geometry of the design I of the water loaded polarization reconfigurable antenna developed in [69]. (a) Cross-sectional view. (b) Top view. (Reproduced from [69] with permission. Copyright ©2017 IEEE).



**FIGURE 30.** Cross-sectional view of the design II and III of the water loaded polarization reconfigurable antenna developed in [69]. (Reproduced from [69] with permission. Copyright ©2017 IEEE).

modes. This CP frequency reconfigurable water antenna was fed through an Archimedean spiral slot which functioned as a frequency-independent feeding mechanism.

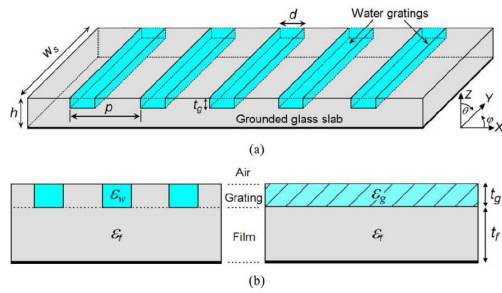
A single-feed water-loaded microstrip antenna having polarization reconfigurability was reported in [69]. Polarization agility was achieved by loading and controlling distilled water cylinders located at the four corners of a square patch antenna. By controlling the height of the water level inside



**FIGURE 31.** Structure of the probe-fed unidirectional surface-wave launcher utilized in the developed antenna in [30]. (a) Top view. (b) O-O cut plane. (Reproduced from [30] with permission. Copyright ©2014 IEEE).

the cylinders, the antenna was switched among linear polarization (LP), right-hand circular polarization (RHCP) and left-hand circular polarization (LHCP). Two design scenarios were studied in this research. Figure 29 illustrates the configuration of design I where the cylinders were installed on top of the substrate of the square patch, whereas Figure 30 shows that water cylinders appeared between the ground plane and substrate. The radius of the tube was the only difference between design II and III. The tubes were identical and made with PVC. From the numerical analysis, it was found that water cylinders had more influence on the tuning range of the antenna for design II or III as compared to design I, it happened due to the stronger electric field in the space between the patch and ground compared to the field on the patch surface. When the heights of the water level in the cylinders were same, the antenna operated in LP mode, whereas, when the water heights were slightly different with a specific difference, two degenerate orthogonal modes having same magnitudes were excited and the antenna operated in CP mode. The CP handedness was switched by simply swapping the heights of the water level of the four cylinders. This reconfigurable antenna achieved an excellent performance in all polarization states. The 1-dB impedance bandwidth of the antenna was 14.5 MHz and 3-dB AR bandwidth was 3.7 MHz. The antenna achieved an efficiency of over 75% over the entire operating band at the three polarization states. The antenna maintained a stable gain of nearly 6 dBi across the entire operating frequency band for these three polarization states.

A pattern reconfigurable leaky-wave antenna using periodic water grating on top of a grounded glass slab was designed in [30]. The demonstrated antenna operated at 5.5 GHz band. The antenna topology consisted of a surface-wave launcher and a periodic water grating. Figure 31, 32 and 33 exhibit the structure of the probe-fed unidirectional surface-wave launcher, structure of the periodic water grating and the fabricated prototype of the water grating leaky-wave antenna, respectively. The unidirectional surface-wave launcher was probe-fed through a grounded glass slab. The parabolic reflecting wall and the reflecting post were utilized



**FIGURE 32.** (a) Perspective view of the periodic water grating structure utilized in the developed antenna in [30]. (b) Side view of the periodic water grating structure and the relevant structure of the grating layer replaced by a uniform slab layer. (Reproduced from [30] with permission. Copyright ©2014 IEEE).

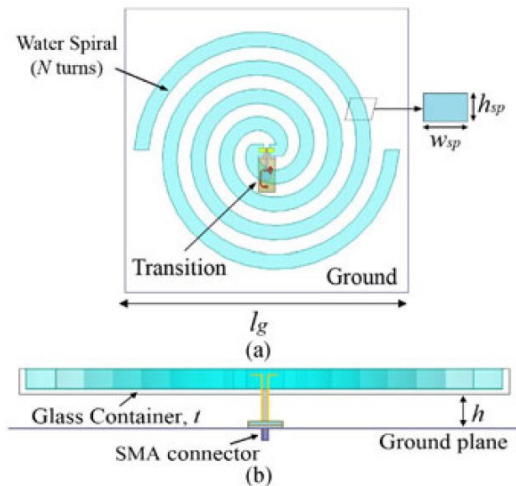


**FIGURE 33.** Prototype of the fabricated dynamic water grating leaky-wave antenna utilized in the developed antenna in [30]. (Reproduced from [30] with permission. Copyright ©2014 IEEE).

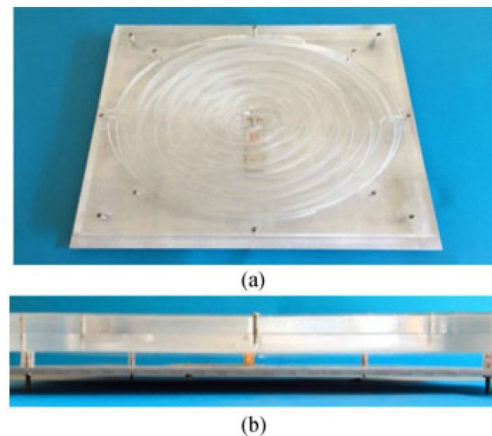
to convert the cylindrical waves excited by the coaxial probe to plane waves propagating through the grounded glass layer. The gratings were formed by a series of narrow grooves cut on top of the grounded glass slab. This glass wall separated the adjacent grooves. By controlling the water flow in the grooves, beam-pointing angle was drifted from  $-32^\circ$  to  $18^\circ$  within a gain ripple of 2.2 dB.

A broadband, low profile and circularly polarized water spiral antenna having polarization reconfigurability was reported in [29]. The reported antenna was an Archimedean spiral antenna consisting of two water arms feeding by a parallel stripline. The arms were located on top of a square conducting plate, made with aluminum, to generate unidirectional radiation patterns. A glass container made with acrylics was used as the water holder for the antenna. The upper spiral was used to produce left-hand circular polarization (LHCP) and the lower one was used to produce right-hand circular polarization (RHCP). By controlling the water level in the channels, the polarization state was switched between LHCP and RHCP. The geometry of the Archimedean water spiral antenna and the fabricated prototype are shown in Figure 34 and Figure 35, respectively. The schematics of the polarization states are demonstrated in Figure 36. The antenna achieved an overall 10-dB impedance bandwidth of 40% for both polarization states, the achieved radiation efficiency was nearly 45%, and the gain was more than 6.3 dBi in the operating band with a maximum achieved gain of 8.6 dBi.

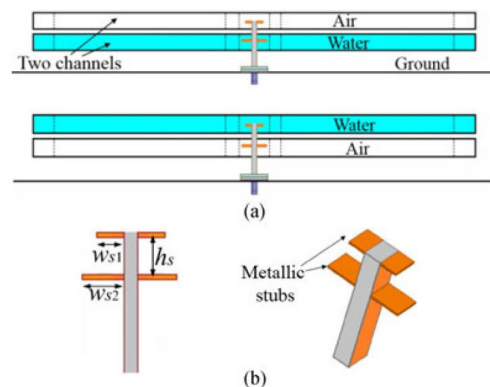
Pattern reconfigurable antennas are highly useful in compact circuit applications where it requires to move the direction of the beams for establishing effective communications links between frequently variable transmitters and/or receivers. However, most of the pattern reconfigurable antennas are designed with active electronic devices which increase the losses in high frequency applications. So, mechanically



**FIGURE 34.** Geometry of the Archimedean water spiral antenna developed in [29]. (a) Top view. (b) Side view. (Reproduced from [29] with permission. Copyright ©2017 IEEE).



**FIGURE 35.** Photograph of the fabricated water spiral antenna developed in [29]. (a) Perspective view. (b) Side view. (Reproduced from [29] with permission. Copyright ©2017 IEEE).



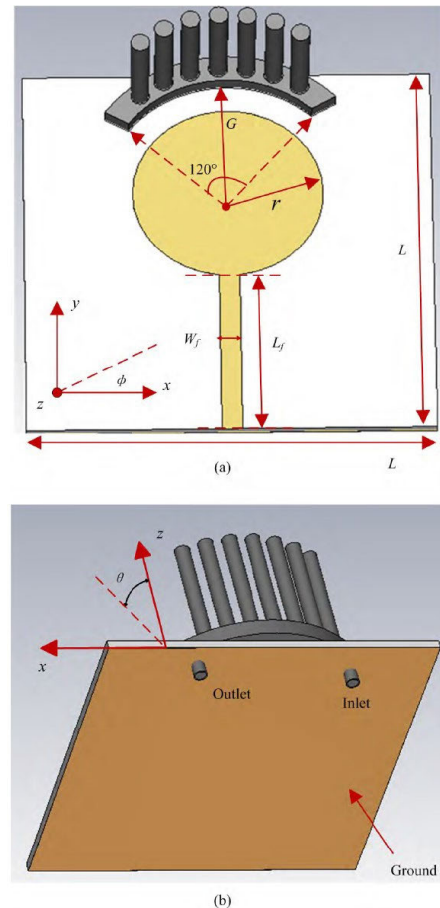
**FIGURE 36.** Polarization-reconfigurable water spiral antenna developed in [29]. (a) Two polarization cases. (b) Parallel stripline with two pairs of thin metallic stubs. (Reproduced from [29] with permission. Copyright ©2017 IEEE).

reconfigurable antennas are efficient choices for tuning the antenna characteristics. As mentioned before, shape, size and volume of water are easily adjustable which have been utilized to develop water-based pattern reconfigurable antennas.

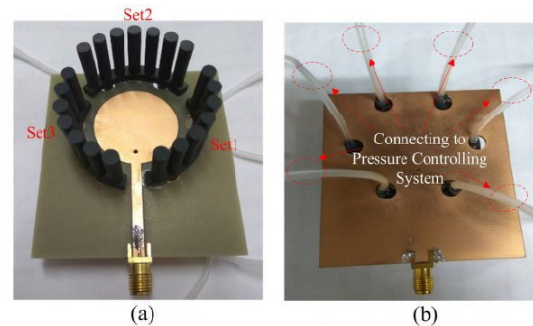


A pattern reconfigurable MIMO antenna using distilled water was proposed in [70] where patterns were tuned by controlling the water level inside the holders made from acrylic plastic. A good pattern tunability with high-isolation ( $>35$  dB) was achieved in this MIMO design. However, this design required a large volume of water which made the antenna bulky and heavy and the loading and unloading process of water was quite slow, thus, this design was not appropriate for compact high speed communication systems. A lightweight, small and fast pattern reconfigurable antenna based on water grating reflector was demonstrated in [28], whose configuration is shown in Figure 37. The antenna is a planar circular monopole constituting an arc-shape three sets of water grating reflectors along the edge of the circular monopole with an angular interval of  $120^\circ$ . The cylindrical hollow gratings were made with photo-polymer resin in a 3-D printer. Each set of grating consists of seven hollow cylindrical pipes. An arc-shape hollow pedestal, inlet and outlet holes and a pressure controlling system were used to load and unload the water in the gratings. By loading and unloading water in these gratings, three different mode, each having specific radiation pattern directions, were achieved with this design. In Mode 1, set 1 pipes were filled with water, but set 2 and 3 were empty; in Mode 2, set 2 pipes were filled with water, but set 1 and 3 were empty; in Mode 3, set 3 pipes were filled with water, but set 1 and 2 were empty. In Mode 1, the maximum radiation beam direction was pointed towards  $300^\circ$  having a peak gain of about 4.5 dBi. In Mode 2, the maximum radiation beam direction was pointed towards around  $180^\circ$  having a peak gain of about 4.1 dBi and in Mode 3, the maximum radiation beam direction was pointed towards near  $60^\circ$  having a peak gain of about 4.5 dBi. The fabricated prototype of the antenna is illustrated in Figure 38.

Water is a prominent material for the realization of reconfigurable antennas. The liquidity and optical transparency of the water make it a suitable material for the development of reconfigurable antennas. Most of the reconfigurable water antennas achieve the frequency, pattern and polarization tuning by controlling the water level inside the container. Achieving reconfigurability by controlling the water level is considered as an efficient tuning method because it is free from the losses induced from lumped electronic components. However, designing efficient feeding method is often challenging in reconfigurable water antennas. Maintaining good impedance matching in different operating states is certainly challenging. Moreover, while controlling the water level inside the container, there is a chance of leakage. To avoid these challenges, wideband feeding method such as disk loaded probe and robust materials are selected for fabricating the container. The most promising advantage of water antennas is the realization of pattern reconfigurable antennas by mechanical tuning method. In literature, most of the pattern reconfigurable antennas are realized with electronic tuning method, whereas water based reconfigurable antennas can be easily designed with mechanically controlling the water level or changing the shape of the water. However, loading



**FIGURE 37.** Configuration of the demonstrated pattern-reconfigurable antenna developed in [28]: (a) front side. (b) back side. (Reproduced from [28] under a Creative Commons Attribution 4.0 International License (CC BY 4.0)).



**FIGURE 38.** Prototype of the demonstrated pattern-reconfigurable antenna in [28]: (a) Front side; (b) Back side. (Reproduced from [28] under a Creative Commons Attribution 4.0 International License (CC BY 4.0)).

and unloading process of water inside the container should be designed properly to avoid possible leakage and unnecessary bulkiness and weight of the antenna.

## VII. DEVELOPMENT OF TRANSPARENT ANTENNAS FROM WATER

The most significant advantage of water is its transparency and liquidity. Water is an excellent candidate for the development of transparent antennas as well as flexible antennas. Most of the research efforts towards the development of water based antennas used transparent materials in the water



holder, so these antennas have transparent geometries. From the literature, it can be observed that most of the water antennas used glass or plastic as the holder material. For example, [24], [27], [29], [70] used transparent acrylics as the material for the water holder, the structures of these antennas are transparent except the ground plane.

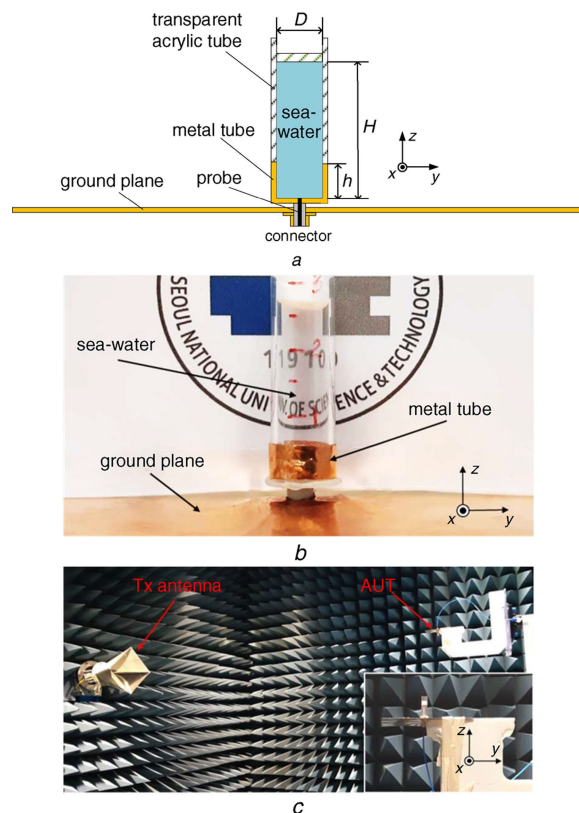
Reference [35] used transparent plexiglass made container to hold pure water, in this work, water was used to create dielectric patch and dielectric ground plane, the antenna was defined as dense dielectric patch antenna. The developed antenna was fully transparent except the small feeding strip.

The wideband F-Shaped water monopole antenna developed in [57] was optically transparent. This antenna used transparent acrylic plastic tube to hold the water. The topology of the antenna was transparent except the ground plane.

A compact wideband optically transparent water patch antenna was explored in [71]. In the explored design, both the patch and the ground plane were realized from pure water hold by plexiglass made container. An annular water ring was mounted under the water patch which shifted the center frequency from 2.3 GHz to 1.95 GHz, subsequently reduced the corresponding size of the water patch by 28%. The antenna was fed through a disk-loaded probe for maintaining wide impedance bandwidth. The realized antenna achieved a wide impedance bandwidth of 41.8%, maximum gain of 1.56 dBi, and maximum radiation efficiency of 78%.

A transparent and highly efficient sea-water monopole antenna operating at 2.4 GHz wireless local area network (WLAN) band was developed in [72]. Figure 39 depicts the configurations and fabricated prototype of the antenna. The antenna consisted of a clear acrylic tube mounted on a ground plane, which hold the sea water. The antenna was fed through an SMA connector. To improve the excitation and, therefore, to improve the efficiency of the antenna, a small metallic tube with a metal disk at its base was attached to the feeding probe. It was explored that the salinity of the sea-water degraded the performance of the antenna, therefore, in this design, the salinity of the sea-water solution was fixed at 35 ppt. Because of the utilization of clear acrylic tube (having a transparency of nearly 90%), the transparency of the antenna was very high (nearly 85%). Figure 39 (b) demonstrates the high optical transparency of the fabricated prototype, where the printed Seoultech's logo placed underneath the antenna is clearly visible through the antenna. The antenna achieved 1.1 GHz (2.1–3.2 GHz) impedance bandwidth, 2.3 dBi gain and 71% radiation efficiency.

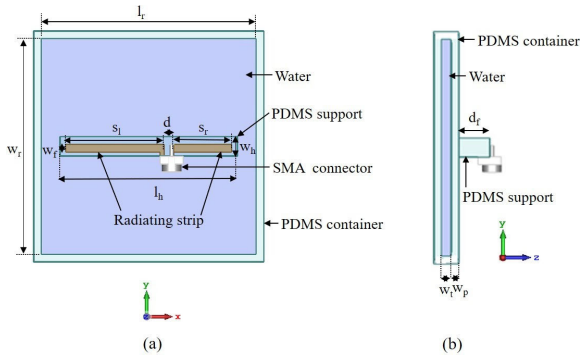
In [31], a research investigation was accomplished to develop transparent and flexible unidirectional antenna using pure water. In this research, a rectangular hollow container was made from PDMS which is a transparent and flexible polymer, so the container was highly transparent and flexible. The hollow PDMS container was made by using 3-D printed molds and heat-curing technology. Water was injected inside the hollow container using syringe. The main radiator of this antenna was an off-center-fed dipole which was realized with transparent and flexible conductive fabric named



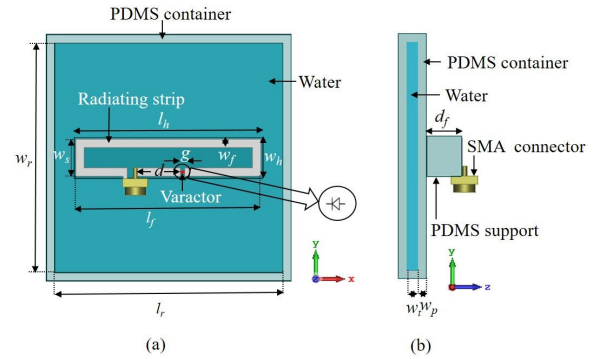
**FIGURE 39.** The transparent sea-water monopole antenna developed in [72]. (a) Cross-section view. (b) Prototype of the antenna placed on top of a printed logo (c) Prototype inside the anechoic chamber for measurement. (Reproduced from [72] with permission. Copyright ©2020 The Institution of Engineering and Technology).

VeilShield invented by Less EMF Inc., USA. The dipole was mounted on top of the water layer hold by PDMS container. The high dielectric contrast between the water and air (and PDMS) lead to the reflection of the waves from the water layer and the antenna functioned as a unidirectional antenna like conventional patch antenna. The unique characteristic of the antenna was its excellent transparency and flexibility. As both the dipole radiator and water holder were made from transparent and flexible materials, the entire antenna structure was highly transparent and flexible. The antenna was unidirectional and was intended to apply in wearable applications. To assess its compatibility near human body environment, it was tested on phantom and showed excellent performance. In free space, peak gain and efficiency were 3.2 dBi and 56%, respectively, whereas on-phantom, the peak gain and efficiency were 3.3 dBi and 50%, respectively. This antenna was the thinnest water based unidirectional antenna. The configuration of the water antenna is exhibited in Figure 40, the fabricated prototype of the antenna is shown in Figure 41, the bent view demonstrates the high flexibility of the antenna.

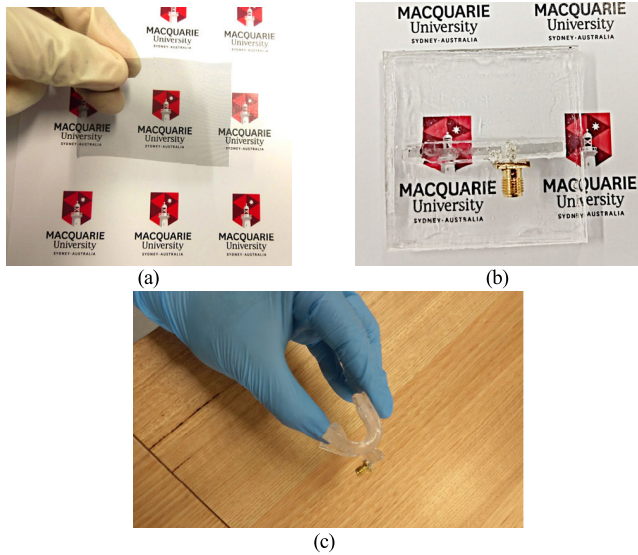
Applying similar technology of [31], a water based transparent and flexible frequency reconfigurable unidirectional antenna was developed in [32]. The antenna used similar PDMS made water container. The main radiator of this antenna was a folded dipole made from transparent con-



**FIGURE 40.** Configuration of the flexible and transparent water antenna. (a) Top view, (b) side view. (Reproduced from [31] with permission. Copyright ©2020 IEEE).



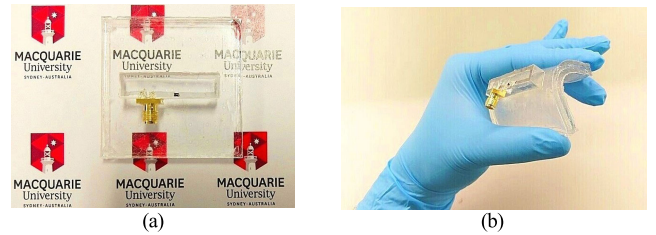
**FIGURE 42.** Configuration of the flexible and transparent reconfigurable water antenna. (a) Top view, (b) Side view. (Reproduced from [32] under a Creative Commons Attribution 4.0 International License (CC BY 4.0)).



**FIGURE 41.** (a) A VeilShield sample demonstrating its transparency, (b) The antenna prototype, (c) Antenna bent to a very low radius curvature. (Reproduced from [31] with permission. Copyright ©2020 IEEE).

ductive fabric VeilShield where a varactor diode was integrated to achieve frequency tuning. The tiny varactor diode did not jeopardize the transparency and flexibility of the antenna. Folded dipole radiator is a closed loop type antenna which avoids the need of additional isolation inductor for this varactor tuned frequency reconfigurable antenna. Isolation inductors are often used in varactor tuned antennas to isolate the biasing DC from the supply RF signals. The antenna developed in [32] was highly transparent and flexible and the antenna achieved a frequency tuning from 2.1 GHz to 3.2 GHz with peak gain varied between 2.1 dBi and 3.2 dBi, and efficiency varied between 40% and 50%. The configuration of the water antenna is exhibited in Figure 42, the fabricated prototype of the antenna is shown in Figure 43, the bent view demonstrates the high flexibility of the antenna.

A wideband water patch antenna having high optical transparency was developed in [73]. The novel L-shaped water probe apparently enhanced the transparency of the antenna and improved the impedance bandwidth. The fabricated water patch antenna achieved a wide impedance bandwidth of



**FIGURE 43.** Antenna prototype: (a) flat state, (b) bent state. (Reproduced from [32] under a Creative Commons Attribution 4.0 International License (CC BY 4.0)).

42.6% (1.48 to 2.28 GHz), maximum peak gain of 7.5 dBi and a maximum radiation efficiency of 67%.

Water can be considered as the most promising material for the development of transparent antennas. Water is almost 100% transparent using a transparent holder made from glass, plastic or polymer making the antenna geometries highly transparent. The earlier version of transparent water antennas used metallic ground plane which diminished the overall transparency of the antennas, but later some water antennas were developed using water made ground plane which was entirely transparent, recently water made feeding probe has been developed which has made the antennas ideally transparent.

### VIII. PROSPECTS OF WATER ANTENNAS

Water is an excellent candidate for developing antennas and microwave devices. Water is transparent, non-toxic, easily available and low-cost liquid. The electrical properties of water can be easily altered by mixing with salt. Water is a liquid, so it is easily deformable, which attributes its excellency in reconfigurable antenna design. The most prominent application of water would be the development of transparent antennas, flexible antennas and reconfigurable antennas. The global transparent electronics industry has a surging market value. It is forecast that the consumer market of transparent electronics will exceed 3800.39 million USD by 2026 [74]. The same study predicts 25% compound annual growth rate (CAGR) of transparent electronics market for the time period 2021-2026 [74]. However, the development of transparent antennas as well as transparent electronics is associated with some particular challenges, such as low electrical conductivity of the transparent conductors, con-

**TABLE 1.** State-of-the-art research approaches towards the development of water-filled antennas.

Ref.	Ant. Type	Water	Water used	Feed	Holder	Freq. (GHz)	Pol.	BW (%)	Gain (dBi)	Effi	Flex.	Trans.
[42]	Truncated Patch	Pure		Patch and Ground L-shaped probe	Resin	1.9	CP	29	3.05	48	No	Yes
[37]	Patch	Pure	Patch	Microstrip	NA	3.98	LP	1	5.6	95	No	NA
[23]	Patch	Pure	Patch	L-shaped probe	Plexiglass	0.9	LP	8	7.3	70	No	Yes
[35]	Patch	Pure	Patch and Ground	Disk loaded probe	Plexiglass	2.4	LP	35	4	82	No	Yes
[43]	Patch with shorting	Pure	Patch	L-probe	Acrylic	0.7	LP	38.5	2	70	No	Yes
[44]	Patch array	Pure	Patch	Aperture couple	NA	2.4	LP	17.21	12.8	NA	NA	NA
[48]	Monopole	Salt	Monopole	Disk loaded probe	Acrylic	0.065	LP	27.8	NA	72.3	No	Yes
[25]	Dynamic Monopole	Salt	Monopole	Shunt excited	Acrylic	0.056	LP	27	2.5	56.2	No	Yes
[45]	Half-loop	Salt	Loop radiator	Capacitive-couple	Metal	0.110	LP	27	-0.2	35	No	No
[51]	Monopole-DRA	Salt-pure	Monopole-Ring	Disk loaded probe	Acrylic	0.07	LP	102	3.2	79	No	No
[56]	Monopole-DRA	Salt-pure	Monopole-Resonator	NA	PVC	0.173	LP	85	1.1	74	NA	No
[46]	Compact Patch	Salt-pure	Patch-Ground	Water disk loaded probe	Resin	2	LP	82.5	0.2	60	Yes	No
[38]	Pattern recon short backfire	Pure	Waveguide	Metal cone loaded probe	Resin	4	NA	11.3	10.8	60	Yes	No
[39]	Pattern recon Horn	Pure	Waveguide	Probe	Resin	4	NA	70.1	11.8	95	Yes	No
[24]	Pattern recon DRA	Pure	Resonator	Slot	Acrylic	0.3	CP	82	6	90	Yes	No
[69]	Pol recon patch	Pure	Resonator	Disk loaded probe	PVC	0.8	LP/CP	48.5	6	75	No	No
[30]	Pattern recon LeakyWave	Pure	Grating	Probe-fed	Glass	5	NA	50	2.2	60	No	No
[29]	Pol recon spiral	Pure	Spiral	Stripline	Glass	1.6	LP/CP	40	8.6	45	Yes	No
[28]	Pattern recon monopole	Pure	Grating	Microstrip	Resin	5.7	LP	1.75	4.5	NA	Yes	No
[71]	Compact patch	Pure	Patch-ground-ring	Disk-loaded probe	Plexiglass	1.95	LP	42	1.56	78	Yes	No
[72]	Monopole	Salt	Monopole	Probe	Acrylic	2.4	LP	43	2.3	71	Yes	No
[31]	Dipole with reflector	Pure	Reflector	Microstrip	PDMS	2.45	LP	6.94	3.2	51	Yes	Yes
[32]	Freq recon dipole	Pure	Reflector	Microstrip	PDMS	2.38-2.67	LP	7	4.07	56.5	Yes	Yes
[73]	Patch	Pure	patch-ground-probe	L-shaped probe	Plexiglass	1.9	LP	42.6	7.5	67	Yes	No

tradictory relationship between the transparency and electrical conductivity and high cost of transparent materials [7]. In contrast to the traditional thin films or metallic meshes, water can be an excellent alternative in designing transparent antennas.

Water has high liquidity which attributes its excellency in realizing flexible antennas and reconfigurable antennas. In recent years, the application of flexible antennas is continuously rising, especially in wearable and biomedical applications. However, the traditional metals and dielectrics are rigid, so are not feasible in flexible antenna development. Different unconventional materials have been explored by the researchers in flexible antenna development. As water is a liquid, it can be an excellent candidate in flexible antenna realization. Moreover, the liquid feature of water makes it an attractive candidate in reconfigurable antenna realization. Reconfigurable antennas are gaining popularity in the modern compact circuit applications, reconfigurable antennas have potential applications in various civilian and military communication networks, such as satellite and radar technologies, aerospace communications, unmanned airborne vehicle (UAV) radars, smart weapon controlling and wearable technologies. Reconfigurability in antennas' operations can be accomplished by physically altering antennas' geometries [58], [60], [61], [75] or integrating electronic components, such as PIN diodes [59], [62], varactor diodes [1], photoconducting switches [63] or RF microelectromechanical (RFMEM) switches [76], [77] within the antenna structures. The integrated lumped electronic components incorporate losses and thus, antenna efficiency is compromised. Therefore, mechanical reconfigurability would be preferred over electronic tuning for efficient antenna operations. As water is easily deformable, it would be an ideal choice in reconfigurable antenna design.

Water can offer prominent opportunity for the development of millimetre-wave broadband high gain antennas. It can be noted that at millimetre-wave band, dielectric resonator antennas would be better choice over metallic antennas

because of the absence of high conduction losses in DRAs at high frequencies [78]. Water can be used to design efficient dielectric resonator antennas and transparent dense dielectric patch antennas (DDPAs) for millimetre-wave band, similar to the developed DDPA in [78].

Water can also be utilized to design all-dielectric metasurfaces and metamaterials [79], [80] which can be employed in designing high gain antennas. Metasurface is a prominent invention in antenna technology, which manipulates the radiation characteristics of the antennas and improves the radiation performance. All-dielectric metasurfaces are low in cost and free from conduction losses, thus, suitable for high frequency operations. Water is a transparent dielectric, so it can be used to design all-dielectric transparent metasurfaces for high gain applications.

Table 1 summarizes some state-of-the-art research approaches towards the development of water-filled antennas. This table demonstrates various types of antennas realized with pure water, salt water and both pure and salt water. Different feeding mechanisms, materials used in water holders and the characteristics of the antennas are also exhibited in this table. It is revealed that different types of antennas have been developed with water, such as monopole antennas, dielectric resonator antennas (DRAs), horn antennas, patch antennas, half-loop antennas and spiral antennas. Moreover, reconfigurable antennas, such as frequency, patterns and polarization reconfigurable antennas have also been successfully developed from water. Different feeding mechanisms have been employed in these water-filled antennas, some of these feeding mechanism particularly utilized for improved performance; for example, the disk-loaded, cone-loaded L-shaped probes and the shunt-excited feeds have been employed for improved bandwidth and radiation efficiency. It can be seen that most of the water-filled antennas used transparent plexiglass, resin and acrylic in the water holders, which make the radiators or the resonators transparent. Besides, the demonstrated works in [35], [46], [71], and [73] used water in realizing both the patch and ground



plane and used transparent materials in the holders, the entire topologies of these antennas are transparent. In addition, the demonstrated works in [31] and [32] used PDMS polymer in fabricating the water holders, these antennas are apparently transparent and flexible. So, it is evident that water has tremendous opportunities in antenna design for future wireless communications.

## IX. CONCLUSION

This paper has highlighted the prospects of water for antenna development. Water has some notable advantages that make it a prominent candidate for the development of antennas for the upcoming communication networks. It is obvious that the application of antennas will spread in broader fields in future, which needs conformal, reconfigurable, unobtrusive and compact antennas. Traditional printed circuit board (PCB) antennas cannot satisfy the required characteristics for future unconventional applications of antennas, so researchers are exploring new materials and fabrication techniques. Water can be an effective alternative material for antenna realization. Water is inexpensive, transparent, easily available, easily transportable and non-toxic liquid, so can be an ideal candidate for designing reconfigurable, transparent or flexible antennas. Water antennas offer a lot of benefits and, thus, open up a new avenue for antenna design in diverse fields for future wireless technology. This paper has reviewed the state-of-the-art research works towards the development of water based antennas. It is the first review paper which briefly presents the novel research explorations of water antennas. This paper has analysed the challenges associated with the development of water antennas, discussed some notable research approaches that investigated new techniques to efficiently feed water antennas, broaden the bandwidth and efficiency of the water antennas and develop reconfigurable, transparent or conformal antennas with water. So, this paper will be a good source of information for designing water-filled antennas and can attract significant attention from the research community.

## REFERENCES

- [1] R. B. V. B. Simorangkir, Y. Yang, K. P. Esselle, and B. A. Zeb, "A method to realize robust flexible electronically tunable antennas using polymer-embedded conductive fabric," *IEEE Trans. Antennas Propag.*, vol. 66, no. 1, pp. 50–58, Jan. 2018.
- [2] A. S. M. Sayem, R. B. V. B. Simorangkir, K. P. Esselle, and R. M. Hashmi, "Development of robust transparent conformal antennas based on conductive mesh-polymer composite for unobtrusive wearable applications," *IEEE Trans. Antennas Propag.*, vol. 67, no. 12, pp. 7216–7224, Dec. 2019.
- [3] L. Yang, A. Rida, R. Vyas, and M. M. Tentzeris, "RFID tag and RF structures on a paper substrate using inkjet-printing technology," *IEEE Trans. Microw. Theory Techn.*, vol. 55, no. 12, pp. 2894–2901, Dec. 2007.
- [4] Z. Hu, Z. Xiao, S. Jiang, R. Song, and D. He, "A dual-band conformal antenna based on highly conductive graphene-assembled films for 5G WLAN applications," *Materials*, vol. 14, no. 17, p. 5087, Sep. 2021. [Online]. Available: <https://www.mdpi.com/1996-1944/14/17/5087>
- [5] H. Arun, "Advancements in the use of carbon nanotubes for antenna realization," *AEU, Int. J. Electron. Commun.*, vol. 136, Jul. 2021, Art. no. 153753. [Online]. Available: <https://www.sciencedirect.com/science/article/pii/S1434841121001503>
- [6] S. Hong, S. H. Kang, Y. Kim, and C. W. Jung, "Transparent and flexible antenna for wearable glasses applications," *IEEE Trans. Antennas Propag.*, vol. 64, no. 7, pp. 2797–2804, Jul. 2016.
- [7] R. B. Green, M. Guzman, N. Izyumskaya, B. Ullah, S. Hia, J. Pitchford, R. Timisina, V. Avrutin, U. Ozgur, H. Morkoc, N. Dhar, and E. Topsakal, "Optically transparent antennas and filters: A smart city concept to alleviate infrastructure and network capacity challenges," *IEEE Antennas Propag. Mag.*, vol. 61, no. 3, pp. 37–47, Jun. 2019.
- [8] G. Sun, B. Muneer, and Q. Zhu, "A study of microstrip antenna made of transparent ITO films," in *Proc. IEEE Antennas Propag. Soc. Int. Symp. (APSURSI)*, Jul. 2014, pp. 1867–1868.
- [9] T. Yasin and R. Baktur, "Inkjet printed patch antennas on transparent substrates," in *Proc. IEEE Antennas Propag. Soc. Int. Symp.*, Jul. 2010, pp. 1–4.
- [10] D. Kim, R. G. Pierce, R. Henderson, S. J. Doo, K. Yoo, and J.-B. Lee, "Liquid metal actuation-based reversible frequency tunable monopole antenna," *Appl. Phys. Lett.*, vol. 105, no. 23, Dec. 2014, Art. no. 234104.
- [11] J.-H. So, J. Thelen, A. Qusba, G. J. Hayes, G. Lazzi, and M. D. Dickey, "Reversibly deformable and mechanically tunable fluidic antennas," *Adv. Funct. Mater.*, vol. 19, no. 22, pp. 3632–3637, 2009.
- [12] M. Rashed Khan, G. J. Hayes, J.-H. So, G. Lazzi, and M. D. Dickey, "A frequency shifting liquid metal antenna with pressure responsiveness," *Appl. Phys. Lett.*, vol. 99, no. 1, Jul. 2011, Art. no. 013501.
- [13] B. Aissa, M. Nedil, M. A. Habib, E. Haddad, W. Jamroz, D. Theriault, Y. Coulibaly, and F. Rosei, "Fluidic patch antenna based on liquid metal alloy/single-wall carbon-nanotubes operating at the S-band frequency," *Appl. Phys. Lett.*, vol. 103, no. 6, Aug. 2013, Art. no. 063101.
- [14] S. Cheng, A. Rydberg, K. Hjort, and Z. Wu, "Liquid metal stretchable unbalanced loop antenna," *Appl. Phys. Lett.*, vol. 94, no. 14, 2009, Art. no. 144103.
- [15] E. Paraschakis, H. Fayad, and P. Record, "Ionic liquid antenna," in *Proc. IEEE Int. Workshop Antenna Technol., Small Antennas Novel Metamater. (IWAT)*, Mar. 2005, pp. 552–554.
- [16] R. C. Chiechi, E. A. Weiss, M. D. Dickey, and G. M. Whitesides, "Eutectic gallium–indium (EGaIn): A moldable liquid metal for electrical characterization of self-assembled monolayers," *Angew. Chem. Int. Ed.*, vol. 47, no. 1, pp. 142–144, 2008.
- [17] T. Meissner and F. J. Wentz, "The complex dielectric constant of pure and sea water from microwave satellite observations," *IEEE Trans. Geosci. Remote Sens.*, vol. 42, no. 9, pp. 1836–1849, Sep. 2004.
- [18] W. J. Ellison, "Permittivity of pure water, at standard atmospheric pressure, over the frequency range 0–25 THz and the temperature range 0–100 °C," *J. Phys. Chem. Reference Data*, vol. 36, no. 1, pp. 1–18, Mar. 2007.
- [19] R. E. Jacobsen, A. V. Lavrinenko, and S. Arslanagic, "A water-based Huygens dielectric resonator antenna," *IEEE Open J. Antennas Propag.*, vol. 1, pp. 493–499, 2020.
- [20] R. Zhou, H. Zhang, and H. Xin, "A compact water based dielectric resonator antenna," in *Proc. IEEE Antennas Propag. Soc. Int. Symp.*, Jun. 2009, pp. 1–4.
- [21] R. Zhou, H. Zhang, and H. Xin, "Liquid-based dielectric resonator antenna and its application for measuring liquid real permittivities," *IET Microw. Antennas Propag.*, vol. 8, no. 4, pp. 255–262, Mar. 2014.
- [22] S. K. K. Dash, T. Khan, and A. De, "Dielectric resonator antennas: An application oriented survey," *Int. J. RF Microw. Comput.-Aided Eng.*, vol. 27, no. 3, Mar. 2017, Art. no. e21069.
- [23] Y. Li and K.-M. Luk, "A water dense dielectric patch antenna," *IEEE Access*, vol. 3, pp. 274–280, 2015.
- [24] M. Zou, Z. Shen, and J. Pan, "Frequency-reconfigurable water antenna of circular polarization," *Appl. Phys. Lett.*, vol. 108, no. 1, 2016, Art. no. 014102.
- [25] C. Hua and Z. Shen, "Shunt-excited sea-water monopole antenna of high efficiency," *IEEE Trans. Antennas Propag.*, vol. 63, no. 11, pp. 5185–5190, Nov. 2015.
- [26] H. Fayad and P. Record, "Broadband liquid antenna," *Electron. Lett.*, vol. 42, no. 3, pp. 133–134, Feb. 2006.
- [27] M. Wang and Q.-X. Chu, "High-efficiency and wideband coaxial dual-tube hybrid monopole water antenna," *IEEE Antennas Wireless Propag. Lett.*, vol. 17, no. 5, pp. 799–802, May 2018.
- [28] J.-J. Liang, G.-L. Huang, K.-W. Qian, S.-L. Zhang, and T. Yuan, "An azimuth-pattern reconfigurable antenna based on water grating reflector," *IEEE Access*, vol. 6, pp. 34804–34811, 2018.
- [29] Z. Hu, S. Wang, Z. Shen, and W. Wu, "Broadband polarization-reconfigurable water spiral antenna of low profile," *IEEE Antennas Wireless Propag. Lett.*, vol. 16, pp. 1377–1380, 2017.
- [30] Z. Hu, Z. Shen, and W. Wu, "Reconfigurable leaky-wave antenna based on periodic water grating," *IEEE Antennas Wireless Propag. Lett.*, vol. 13, pp. 134–137, 2014.



- [31] A. S. M. Sayem, R. B. V. B. Simorangkir, K. P. Esselle, R. M. Hashmi, and H. Liu, "A method to develop flexible robust optically transparent unidirectional antennas utilizing pure water, PDMS, and transparent conductive mesh," *IEEE Trans. Antennas Propag.*, vol. 68, no. 10, pp. 6943–6952, Oct. 2020.
- [32] A. S. M. Sayem, R. B. V. B. Simorangkir, K. P. Esselle, D. N. Thalakituna, and A. Lalbakhsh, "An electronically-tunable, flexible, and transparent antenna with unidirectional radiation pattern," *IEEE Access*, vol. 9, pp. 147042–147053, 2021.
- [33] E. Motovilova and S. Y. Huang, "A review on reconfigurable liquid dielectric antennas," *Materials*, vol. 13, no. 8, p. 1863, Apr. 2020.
- [34] Y. Huang, L. Xing, C. Song, S. Wang, and F. Elhouni, "Liquid antennas: Past, present and future," *IEEE Open J. Antennas Propag.*, vol. 2, pp. 473–487, 2021.
- [35] J. Sun and K.-M. Luk, "A wideband low cost and optically transparent water patch antenna with omnidirectional conical beam radiation patterns," *IEEE Trans. Antennas Propag.*, vol. 65, no. 9, pp. 4478–4485, Sep. 2017.
- [36] S. P. Kingsley and S. G. O'Keefe, "Beam steering and monopulse processing of probe-fed dielectric resonator antennas," *IEE Proc.-Radar, Sonar Navigat.*, vol. 146, no. 3, pp. 121–125, 1999.
- [37] H. W. Lai, K.-M. Luk, and K. W. Leung, "Dense dielectric patch antenna—A new kind of low-profile antenna element for wireless communications," *IEEE Trans. Antennas Propag.*, vol. 61, no. 8, pp. 4239–4245, Aug. 2013.
- [38] Z. Ren, S.-S. Qi, W. Wu, and Z. Shen, "Function-reconfigurable water short backfire antenna," *IEEE Access*, vol. 8, pp. 203667–203673, 2020.
- [39] Z. Ren, S.-S. Qi, W. Wu, and Z. Shen, "Pattern-reconfigurable water horn antenna," *IEEE Trans. Antennas Propag.*, vol. 69, no. 8, pp. 5084–5089, Aug. 2021.
- [40] R. E. Jacobsen, A. V. Lavrinenko, and S. Arslanagic, "Electrically small water-based hemispherical dielectric resonator antenna," *Appl. Sci.*, vol. 9, no. 22, p. 4848, Nov. 2019.
- [41] C. Hua, S. Wang, Z. Hu, Z. Zhu, Z. Ren, W. Wu, and Z. Shen, "Reconfigurable antennas based on pure water," *IEEE Open J. Antennas Propag.*, vol. 2, pp. 623–633, 2021.
- [42] J. Sun and K.-M. Luk, "A circularly polarized water patch antenna," *IEEE Antennas Wireless Propag. Lett.*, vol. 19, no. 6, pp. 926–929, Jun. 2020.
- [43] Y.-H. Qian and Q.-X. Chu, "A compact broadband water patch antenna," *IEEE Antennas Wireless Propag. Lett.*, vol. 16, pp. 1911–1914, 2017.
- [44] J. Sun and K.-M. Luk, "Design of a  $2 \times 2$  water dielectric patch antenna array for Wi-Fi application," in *Proc. IEEE 4th Asia-Pacific Conf. Antennas Propag. (APCAP)*, Jun. 2015, pp. 237–238.
- [45] C. Hua and Z. Shen, "Sea-water half-loop antenna for maritime wireless communications," in *Proc. IEEE 4th Asia-Pacific Conf. Antennas Propag. (APCAP)*, Jun. 2015, pp. 231–232.
- [46] J. Li, J. Fang, P. Xiao, J. Dong, S. Du, G. Li, and W. T. Joines, "A fan-shaped compact water antenna with wide bandwidth and optical transparency," *IEEE Trans. Antennas Propag.*, vol. 70, no. 4, pp. 3017–3021, Apr. 2022.
- [47] L. Xing, Y. Huang, S. S. Alja'afreh, and S. J. Boyes, "A monopole water antenna," in *Proc. Loughborough Antennas Propag. Conf. (LAPC)*, Nov. 2012, pp. 1–4.
- [48] C. Hua, Z. Shen, and J. Lu, "High-efficiency sea-water monopole antenna for maritime wireless communications," *IEEE Trans. Antennas Propag.*, vol. 62, no. 12, pp. 5968–5973, Dec. 2014.
- [49] R. King and T. Wu, "The imperfectly conducting cylindrical transmitting antenna," *IEEE Trans. Antennas Propag.*, vol. AP-14, no. 5, pp. 524–534, Sep. 1966.
- [50] Z. Peng, X. Liang, W. Zhu, J. Geng, C. He, Y. Yao, Y. Qian, and R. Jin, "Metal-loaded seawater antenna with high radiation efficiency and wide-band characteristics," *IEEE Antennas Wireless Propag. Lett.*, vol. 16, pp. 1671–1674, 2017.
- [51] Y.-H. Qian and Q.-X. Chu, "Broadband hybrid water antennas," in *Proc. IEEE 4th Asia-Pacific Conf. Antennas Propag. (APCAP)*, Jun. 2015, pp. 235–236.
- [52] A. Ittipiboon, A. Petosa, and S. Thirakoune, "Bandwidth enhancement of a monopole using dielectric resonator antenna loading," in *Proc. 9th Int. Symp. Antenna Technol. Appl. Electromagn.*, 2002, pp. 1–4.
- [53] M. Lapierre, Y. M. M. Antar, A. Ittipiboon, and A. Petosa, "Ultra wideband monopole/dielectric resonator antenna," *IEEE Microw. Wireless Compon. Lett.*, vol. 15, no. 1, pp. 7–9, Jan. 2005.
- [54] D. Guha and Y. Antar, "Four-Element cylindrical dielectric resonator antenna for wideband monopole-like radiation," *IEEE Trans. Antennas Propag.*, vol. 54, no. 9, pp. 2657–2662, Sep. 2006.
- [55] L. Xing, Y. Huang, Q. Xu, S. Alja'afreh, and T. Liu, "A broadband hybrid water antenna for hand-portable applications," *IEEE Antennas Wireless Propag. Lett.*, vol. 15, pp. 174–177, 2016.
- [56] Y.-H. Qian and Q.-X. Chu, "A broadband hybrid monopole-dielectric resonator water antenna," *IEEE Antennas Wireless Propag. Lett.*, vol. 16, pp. 360–363, 2017.
- [57] L. Xing, Y. Huang, Q. Xu, and S. Alja'afreh, "A wideband hybrid water antenna with an F-shaped monopole," *IEEE Access*, vol. 3, pp. 1179–1187, 2015.
- [58] S. J. Chen, D. C. Ranasinghe, and C. Fumeaux, "A robust snap-on button solution for reconfigurable wearable textile antennas," *IEEE Trans. Antennas Propag.*, vol. 66, no. 9, pp. 4541–4551, Sep. 2018.
- [59] P.-Y. Qin, Y. J. Guo, A. R. Weily, and C.-H. Liang, "A pattern reconfigurable U-slot antenna and its applications in MIMO systems," *IEEE Trans. Antennas Propag.*, vol. 60, no. 2, pp. 516–528, Feb. 2012.
- [60] C. Wang, J. C. Yeo, H. Chu, C. T. Lim, and Y.-X. Guo, "Design of a reconfigurable patch antenna using the movement of liquid metal," *IEEE Antennas Wireless Propag. Lett.*, vol. 17, no. 6, pp. 974–977, Jun. 2018.
- [61] H. L. Zhu, S. W. Cheung, X. H. Liu, and T. I. Yuk, "Design of polarization reconfigurable antenna using metasurface," *IEEE Trans. Antennas Propag.*, vol. 62, no. 6, pp. 2891–2898, Jun. 2014.
- [62] G. Yang, J. Li, D. Wei, S.-G. Zhou, and R. Xu, "Pattern reconfigurable microstrip antenna with multidirectional beam for wireless communication," *IEEE Trans. Antennas Propag.*, vol. 67, no. 3, pp. 1910–1915, Mar. 2019.
- [63] C. J. Panagamuwa, A. Chauraya, and J. C. Vardaxoglou, "Frequency and beam reconfigurable antenna using photoconducting switches," *IEEE Trans. Antennas Propag.*, vol. 54, no. 2, pp. 449–454, Feb. 2006.
- [64] S. G. O'Keefe and S. P. Kingsley, "Tunability of liquid dielectric resonator antennas," *IEEE Antennas Wireless Propag. Lett.*, vol. 6, pp. 533–536, 2007.
- [65] Z. Ren, S.-S. Qi, Z. Hu, Z. Shen, and W. Wu, "Wideband water helical antenna of circular polarization," *IEEE Trans. Antennas Propag.*, vol. 67, no. 11, pp. 6770–6777, Nov. 2019.
- [66] H. Huang, S. Gao, S. Lin, and L. Ge, "A wideband water patch antenna with polarization diversity," *IEEE Antennas Wireless Propag. Lett.*, vol. 19, no. 7, pp. 1113–1117, Jul. 2020.
- [67] S. Wang, Z. Hu, W. Wang, S. Qi, and W. Wu, "Analysis and design of sea-water monopole Yagi-Uda antenna with pattern reconfigurability," *Int. J. RF Microw. Comput. Aided Eng.*, vol. 28, no. 8, Oct. 2018, Art. no. e21399.
- [68] L. Xing, J. Zhu, Q. Xu, D. Yan, and Y. Zhao, "A circular beam-steering antenna with parasitic water reflectors," *IEEE Antennas Wireless Propag. Lett.*, vol. 18, no. 10, pp. 2140–2144, Oct. 2019.
- [69] Y.-H. Qian and Q.-X. Chu, "A polarization-reconfigurable water-loaded microstrip antenna," *IEEE Antennas Wireless Propag. Lett.*, vol. 16, pp. 2179–2182, 2017.
- [70] Y.-H. Qian and Q.-X. Chu, "A pattern-reconfigurable water-loaded MIMO antenna," *Microw. Opt. Technol. Lett.*, vol. 59, no. 7, pp. 1608–1613, Jul. 2017.
- [71] J. Sun and K.-M. Luk, "A compact-size wideband optically-transparent water patch antenna incorporating an annular water ring," *IEEE Access*, vol. 7, pp. 122964–122971, 2019.
- [72] D. T. Phan and C. W. Jung, "Optically transparent sea-water monopole antenna with high radiation efficiency for WLAN applications," *Electron. Lett.*, vol. 55, no. 24, pp. 1269–1271, Nov. 2019.
- [73] J. Sun and K.-M. Luk, "A fully transparent wideband water patch antenna with L-shaped feed," *IEEE Open J. Antennas Propag.*, vol. 2, pp. 968–975, 2021.
- [74] Mordor Intelligence. (2022). *Intelligence. Transparent Electronics Market-Growth, Trends, COVID-19 Impact, and Forecasts (2022–2027)*. [Online]. Available: <https://www.mordorintelligence.com/industry-reports/transparent-electronics-market>
- [75] T. Jang, C. Zhang, H. Youn, J. Zhou, and L. J. Guo, "Semitransparent and flexible mechanically reconfigurable electrically small antennas based on tortuous metallic micromesh," *IEEE Trans. Antennas Propag.*, vol. 65, no. 1, pp. 150–158, Jan. 2017.
- [76] N. Kingsley, D. E. Anagnostou, M. Tentzeris, and J. Papapolymerou, "RF MEMS sequentially reconfigurable Sierpinski antenna on a flexible organic substrate with novel DC-biasing technique," *J. Microelectromech. Syst.*, vol. 16, no. 5, pp. 1185–1192, Oct. 2007.
- [77] G. Wang, R. Bairavasubramanian, B. Pan, and J. Papapolymerou, "Radiofrequency MEMS-enabled polarisation-reconfigurable antenna arrays on multilayer liquid crystal polymer," *IET Microw., Antennas Propag.*, vol. 5, no. 13, pp. 1594–1599, 2011.

- [78] Y. Li and K.-M. Luk, "A 60-GHz dense dielectric patch antenna array," *IEEE Trans. Antennas Propag.*, vol. 62, no. 2, pp. 960–963, Feb. 2014.
- [79] R. E. Jacobsen, A. V. Lavrinenko, and S. Arslanagić, "Water-based metasurfaces for effective switching of microwaves," *IEEE Antennas Wireless Propag. Lett.*, vol. 17, no. 4, pp. 571–574, Apr. 2018.
- [80] A. Andryieuski, S. M. Kuznetsova, S. V. Zhukovsky, Y. S. Kivshar, and A. V. Lavrinenko, "Water: Promising opportunities for tunable all-dielectric electromagnetic metamaterials," *Sci. Rep.*, vol. 5, no. 1, pp. 1–9, 2015.



**ABU SADAT MD. SAYEM** received the B.Sc. (Hons.) and M.Sc. degrees in electrical and electronic engineering from the Rajshahi University of Engineering and Technology, Bangladesh, in 2011 and 2015, respectively, and the Ph.D. degree in electronic engineering (with the Vice-Chancellor's Commendation for Academic Excellence) from Macquarie University, Australia, in 2021.

He worked as an Assistant Professor and a Lecturer at the Department of Electrical and Electronic Engineering, Rajshahi University of Engineering and Technology. He is currently working with the School of Engineering, Macquarie University, and the School of Electrical and Data Engineering, University of Technology Sydney, Australia. His current research interests include wearable antennas, flexible antennas, transparent antennas, and antennas for biomedical applications. He regularly reviews articles for top-class journals in his research field.

Dr. Sayem was a recipient of several prestigious awards and scholarships, including the Vice-Chancellor's Commendation on Ph.D. Thesis, the Commonwealth Government funded International Research Training Program Scholarship to support the Ph.D. in Australia, the Prime Minister Gold Medal from Bangladesh, and the University Gold Medal from the Rajshahi University of Engineering and Technology.



**ALI LALBAKSH** (Senior Member, IEEE) received the B.S. and M.S. degrees in electronic and telecommunication engineering, in 2008 and 2011, respectively, and the Master of Research (H.D.) and Ph.D. degrees in electronics engineering from Macquarie University, Australia, in 2015 and 2020, respectively.

He currently holds an academic position (Macquarie University Research Fellowship) with Macquarie University. He has published over

80 peer-reviewed journals and conference papers. His research interests include satellite communication, high-gain antennas, evolutionary optimization methods, and passive microwave components. He received several prestigious awards, including the International Research Training Program Scholarship (iRTP) for MRes, the International Macquarie University Research Excellence Scholarship (iMQRES) for the Ph.D. degree, the Commonwealth Scientific and Industrial Research Organization (CSIRO) Grants on Astronomy and Space Exploration, the Macquarie University Postgraduate Research Fund (PGRF), and the WiMed Travel Support Grants. He was a recipient of the 2016 ICEAA-IEEE APWC Cash Prize and the Macquarie University Deputy Vice-Chancellor Commendation, in 2017. He was awarded the Third Prize, in 2016; the First Prize, in 2018; and the Second Prize from the International Competition, in 2019. He is the only Researcher at the IEEE Region Ten (Asia-Pacific), who received the Most Prestigious Best Paper Contest of the IEEE Region Ten more than once. He is the Highly Commended Finalist and the Winner of the Excellence in Higher Degree Research Award in Science, Technology, Engineering, Mathematics, and Medicine (STEMM), Macquarie University, in 2019 and 2020, respectively. He has received the Research Excellence Award of the Faculty of Science and Engineering, Macquarie University. He serves as an Associate Editor for the *International Journal of Electronics and Communications* (AEÜ), and *Electronics* (MDPI). In 2020, he was announced as an Outstanding Reviewer of the IEEE TRANSACTIONS ON ANTENNAS AND PROPAGATION.



**KARU P. ESSELLE** (Fellow, IEEE) received the B.Sc. degree (Hons.) in electronic and telecommunication engineering from the University of Moratuwa, Sri Lanka, and the M.A.Sc. and Ph.D. degrees (Hons.) in electrical engineering from the University of Ottawa, Canada.

He was a member of the Dean's Advisory Council and the Division Executive. He was the Head of the Department several times. He is currently a Distinguished Professor of electromagnetic and

antenna engineering with the University of Technology Sydney and a Visiting Professor with Macquarie University, Sydney. Previously, he was the Director of the WiMed Research Centre and the Associate Dean—Higher Degree Research (HDR) with the Division of Information and Communication Sciences and directed the Centre for Collaboration in Electromagnetic and Antenna Engineering, Macquarie University. He has provided expert assistance to more than a dozen companies, including Intel, Hewlett Packard Laboratory (USA), Cisco Systems (USA), Audacy (USA), Cochlear, Optus, ResMed, and Katherine-Werke (Germany). His team designed the high-gain antenna system for the world's first entirely Ka-band CubeSat made by Audacy, USA, and launched to space by SpaceX, in December 2018. This is believed to be the first Australian-designed high-gain antenna system launched to space, since CSIRO-designed antennas in Australia's own Fed-Sat launched in 2002. His research has been supported by many national and international organizations, including Australian Research Council, Intel, U.S. Air Force, Cisco Systems, Hewlett-Packard, Australian Department of Defense, Australian Department of Industry, NSW Chief Scientist and Engineer Office, SmartSat Corporate Research Centre, and German and Indian Governments. He is in world's top 100,000 most-cited scientists list by Mendeley Data. Since 2002, his research team has been involved with research grants, contracts, and Ph.D. scholarships worth about 20 million dollars, including 15 Australian Research Council grants. He is with the College of Expert Reviewers of the European Science Foundation (2019–2022) and he has been invited to serve as an International Expert/Research Grant Assessor by several other research funding bodies as well, including the European Research Council, and funding agencies in Norway, Belgium, The Netherlands, Canada, Finland, Hong Kong, Georgia, South Africa, and Chile. He has been invited by the Vice-Chancellors of Australian and overseas universities to assess applications for promotion to professorial levels. He has also been invited to assess grant applications submitted to Australia's most prestigious schemes, such as an Australian Federation Fellowships and an Australian Laureate Fellowships. He has authored more than 600 research publications and his papers have been cited over 13,500 times. In 2020, his publications received over 1,500 citations per year. His H-index is 55 and i-10 is 226. Since 2002, his research team has been involved with research grants, contracts and Ph.D. scholarships worth over 25 million dollars, including 15 Australian Research Council grants. His research activities are posted in the web at: <http://web.science.mq.edu.au/esselle/> and <https://www.uts.edu.au/staff/karu.esselle>

Dr. Esselle is a fellow of the Royal Society of New South Wales IEEE and Engineers Australia, and the Director of Innovations for Humanity Pty Ltd. In addition to the IEEE Kanada Award mentioned above, several of his papers have been among most cited or most downloaded. Often one or two of his papers are ranked by Web of Science and Clarivate as Highly Cited Papers (top 1% in the academic field of Engineering) for example, two papers are ranked so, for citations received in January to February 2022. Some papers have been ranked as Hot Papers as well (top 0.1% in Engineering), e.g. A Scientific Reports paper for citations received in January to February 2022. His awards include Runner-Up to 2020 Australian National Eureka Prize for Outstanding Mentor of Young Researchers, the 2019 Motohisa Kanda Award (from IEEE USA) for the most cited paper in IEEE TRANSACTIONS ON ELECTROMAGNETIC COMPATIBILITY in the past five years, the 2019 Macquarie University Research Excellence Award for Innovative Technologies, the 2019 ARC Discovery International Award, the 2017 Excellence in Research Award from the Faculty of Science and Engineering, the 2017 Engineering Excellence Award for Best Innovation, the 2017 Highly Commended Research Excellence Award from Macquarie University, the 2017 Certificate of Recognition from IEEE Region 10, the 2016 and 2012 Engineering Excellence Awards for Best Published Paper from IESL NSW Chapter, the 2011 Outstanding Branch Counsellor Award

from IEEE Headquarters (USA), the 2009 Vice Chancellor's Award for Excellence in Higher Degree Research Supervision, and the 2004 Innovation Award for Best Invention Disclosure. His mentees have been awarded many fellowships, awards and prizes for their research achievements. 58 international experts who examined the theses of his Ph.D. graduates ranked them in the top 5% or 10%. Two of his recent students were awarded Ph.D. with the highest honor at Macquarie University—the Vice Chancellor's Commendation, and one received University Medal for Master of Research. According to the Special Report on Research published by The Australian National Newspaper, he is the National Research Field Leader in Australia in both microelectronics and electromagnetics fields in 2019. In 2009, he was the Vice Chancellor's Award for Excellence in Higher Degree Research Supervision and 2004 Innovation Award for best invention disclosure. From 2016 and 2012 Engineering Excellence Awards for Best Published Paper from IESL NSW Chapter, 2011 Outstanding Branch Counsellor Award from IEEE headquarters (USA), 2017 Excellence in Research Award from the Faculty of Science and Engineering, 2017 Engineering Excellence Award for Best Innovation, 2017 Highly Commended Research Excellence Award from Macquarie University, 2017 Certificate of Recognition from IEEE Region 10. Previously he received 2019 Macquarie University Research Excellence Award for Innovative Technologies, and 2019 ARC Discovery International Award. From 2018 to 2020, he chaired the prestigious a Distinguished Lecturer Program Committee of the IEEE Antennas and Propagation (AP) Society, the premier global learned society dedicated for antennas and propagation, which has close to 10,000 members worldwide. After two stages in the selection process, he was also selected by this society as one of two candidates in the ballot for the 2019 President of the Society. Only three people from Asia or Pacific apparently have received this honor in the 68-year history of this society. He is also one of the three distinguished lecturers (DL) selected by the society, in 2016. He is the only Australian to chair the AP DL Program ever, the only Australian AP DL in almost two decades, and second Australian AP DL ever (after UTS Distinguished Visiting Professor Trevor Bird). He has served the IEEE AP Society Administrative Committee in several elected or ex-officio positions (2015–2020). He is also the Chair of the Board of Management of Australian Antenna Measurement Facility. He was the Elected Chair of both IEEE New South Wales (NSW) and IEEE NSW AP/MTT Chapter, in 2016 and 2017, respectively. He is a Track Chair of IEEE AP-S/URSI 2022 Denver, 2021 Singapore and 2020 Montreal; a Technical Program Committee Co-Chair of ISAP 2015, APMC 2011, and TENCON 2013; and the Publicity Chair of ICEAA/IEEE APWC 2016, IWAT 2014, and APMC 2000. He has served as an Associate Editor for IEEE TRANSACTIONS ON ANTENNAS PROPAGATION, *IEEE Antennas and Propagation Magazine*, and IEEE ACCESS. In addition to the large number of invited conference speeches he has given, he has been an Invited Plenary/Extended/Keynote/distinguished Speaker of several IEEE and other venues over 30 times, including EuCAP 2020 Copenhagen, Denmark; URSI 2019 Seville, Spain; and 23rd ICECOM 2019, Dubrovnik, Croatia.



**GHOLAMHOSEIN MOLOUDIAN** (Member, IEEE) received the Associate's degree (Hons.) in electronics (electrical engineering) from Technical and Vocational University, Yasouj, in 2008, the B.Sc. degree in electronics engineering (electrical engineering) from the Higher Education Center, Shiraz, in 2010, the M.Sc. degree (Hons.) in electronics engineering (electrical engineering) from Islamic Azad University (IAU), Bushehr, in 2012, and the Ph.D. degree (Hons.) in electronics engineering (electrical engineering) from IAU, Arak Branch, Iran, in 2018. He worked as a Researcher and a Lecturer with the Department of Electrical Engineering, Salman Farsi University of Kazerun, and IAU Kazerun Branch, from January 2016 to September 2020. He worked with South Electrical Management Company in the field of industrial sensors and energy efficiency, from October 2020 to December 2021. He is currently working with

the Wireless Sensor Network Group (Antenna/RF team), Tyndall National Institute, University College Cork (UCC), Ireland, as a Marie Skłodowska-Curie Research Fellow and a SMART 4.0 Fellow (Smart Manufacturing CONFIRM Center). His research interests include design and analysis of RF/microwave circuits, RF energy harvesting circuits, RFID, rectifying antenna (rectenna), smart sensors, microstrip antennas, photonic devices, smart industry 4.0, and biomedical sensors and antennas.



**JOHN L. BUCKLEY** (Member, IEEE) received the B.Eng. degree from the Cork Institute of Technology (CIT), in 1994, and the M.Eng.Sc. and Ph.D. degrees from University College Cork (UCC), Ireland, in 2004 and 2016, respectively. He was with EMC Corporation, Cork, Ireland, from 1994 to 2002, where he specialized in PCB design, high-speed digital design, and signal integrity. He joined the Tyndall National Institute, University College Cork, in 2005, where he is currently a Senior Researcher and leads the Antenna and RF Team's research activities working on both fundamental and applied antenna and RF research. He has a long track record of developing antenna and RF technologies for industry. He has published more than 50 scientific works and acts as a reviewer for several international antenna journals and conferences. His research interests include electrically small antenna design, tunable antennas, wearable and implantable antennas, and RF front-end design. He was a recipient of commercialization awards for technologies licensed to industry.



**ROY B. V. B. SIMORANGKIR** (Member, IEEE) received the B.S. degree in telecommunication engineering from the Bandung Institute of Technology, Indonesia, in 2010, the M.S. degree in electrical and electronic engineering from Yonsei University, South Korea, in 2014, and the Ph.D. degree in electronic engineering from Macquarie University, Australia, in 2018. He held a teaching staff position at Macquarie University International College, from March 2018 to May 2019. He was also a Postdoctoral Researcher at the Reconfigurable Electronics and Antennas Research Group, Macquarie University, from September 2018 to December 2018. From May 2019 to May 2020, he worked as a Postdoctoral Researcher at the Institute of Electronics and Telecommunications of Rennes (IETR), University of Rennes 1. He is currently working as a Postdoctoral Researcher with the Wireless Sensor Networks Group, Tyndall National Institute, University College Cork. His research interests include design and fabrication of flexible antennas and sensors, reconfigurable antennas, ultra-wideband (UWB) antennas, and leaky wave antennas (LWAs).

Dr. Simorangkir was selected as a Finalist in the Student Paper and Advanced Practice Paper Competitions of the IEEE MTT-S International Microwave Symposium (IMS), Honolulu. In 2017, one of his works receive the First Place in the IEEE Region 10 Student Paper Contest (postgraduate category). He was a Session Chair in the 2018 ACES Symposium, Beijing. He is also serving as a Guest Editor of a Special Issue for *Sensors* journal (MDPI) and *Electronics* journal (MDPI). He has been serving as a Topic Editor for *Sensors* journal (MDPI) and *Electronics* journal (MDPI), and regularly reviews for several reputable journals in his research field.

...