

RESEARCH ARTICLE

Selective Harmonic Elimination in a Multilevel Inverter Using Multi-Criteria Search Enhanced Firefly Algorithm

MUHAMMAD KHIZER¹, SHEROZE LIAQUAT², (Graduate Student Member, IEEE),
MUHAMMAD FAHAD ZIA³, (Member, IEEE), SAIKRISHNA KANUKOLLU⁴,
AHMED AL-DURRA⁴, (Senior Member, IEEE), AND S. M. MUYEEN⁵, (Senior Member, IEEE)

¹Department of Electrical Engineering, University of Engineering and Technology, Lahore 54000, Pakistan

²Department of Electrical Engineering and Computer Science, South Dakota State University, Brookings, SD 57007, USA

³Department of Electrical and Computer Engineering, American University in Dubai, Dubai, United Arab Emirates

⁴Department of Electrical Engineering and Computer Science, Khalifa University, Abu Dhabi, United Arab Emirates

⁵Department of Electrical Engineering, Qatar University, Doha, Qatar

Corresponding author: S. M. Mueeen (sm.mueeen@qu.edu.qa)

This work was supported by the Khalifa University.

ABSTRACT This research paper proposes the new multi-criteria search based enhanced firefly algorithm for solving selective harmonic elimination in a multilevel inverter. This new enhanced firefly utilizes adaptive nature of social and cognitive components to find the global optima. To see the effectiveness of the proposed algorithm and for the evaluation of results, a three phase nine level cascaded multilevel inverter is used. It is compared with existing meta-heuristic algorithms namely particle swarm optimization and firefly algorithm to validate its effectiveness. Crucial parameters for optimization, including population size and number of iterations, are kept same for comparison. For comparison, total harmonic distortion and convergence behaviour of algorithms against various modulation index values are considered. Moreover, results have clearly indicated that the proposed algorithm has surpassed particle swarm optimization and firefly algorithms in terms of convergence behaviour by attaining lower fitness value in lesser number of iterations. Finally, the experimental validation of selective harmonic elimination in multi-level inverter is also performed and analyzed.

INDEX TERMS Cascaded H-bridge multilevel inverter, firefly algorithm, multi-criteria search, selective harmonic elimination.

I. INTRODUCTION

Ability to provide high voltage without connecting devices in series, low stress on semiconductor switches, transformer less structure and improved power quality are few among several advantages offered by multilevel inverters [1]. Owing these advantages, they are extensively employed for power conversion in renewable energy [2], HVDC [3] and flexible AC transmission based systems [4]. Flying capacitor, diode clamped and cascaded H-bridge multilevel inverters (CHBMLI) constitute the basic three topologies of multilevel

inverters. Among these, the cascaded H-bridge topology of multilevel inverters has found substantial applications due to its simple and modular structure [5].

The advantages of multilevel inverters come along with an important issue of waveform distortion due to low order harmonics which reduces their performance and efficiency other than decreasing the lifespan of the system in which these are employed. To enhance the performance and efficiency of multilevel inverters, numerous control and modulation techniques have been reported in the literature. These include high switching frequency based modulation techniques like (sinusoidal pulse width modulation, space vector pulse width modulation etc.) and low switching frequency based methods

The associate editor coordinating the review of this manuscript and approving it for publication was Snehal Gawande¹.

for example, (selective harmonic elimination pulse width modulation (SHEPWM) and space vector control). In the literature, SHEPWM technique is reported to be more significant for control of multilevel inverters. This is due to its capability to control unwanted low order harmonics while operating switches at fundamental frequency [6].

In SHEPWM, firing angles are computed which are used to eliminate particular low order harmonics while keeping fundamental harmonic to a pre-determined fixed value. These firing angles are evaluated offline to eliminate $k - 1$ harmonics by solving SHE equations over full modulation index (MI) range having feasible solutions. These firing angles are stored in memory in the form of lookup table where k denotes the number of firing angles. Although SHEPWM provides promising results in eliminating low order harmonics but it suffers from highly non-linear and transcendental nature SHE equations which require search of efficient methods for solving them.

A. LITERATURE SURVEY

Different methods have been used to solve SHE equations and research is still being carried for the development of new methods for solving them. These methods can be classified into three categories: namely numerical methods, algebraic techniques, and evolutionary computation based algorithms. In Numerical methods, Newton Raphson (NR) is reported in [7] to solve SHE equations. Although numerical methods give promising and accurate solutions but they need an initial guess for their optimal performance and have a tendency to get trapped in local optima which can lead to sub-optimal solution.

Algebraic methods, like method of resultant theory, have also been discussed in the literature to find optimized firing angles [8]. Unlike numerical methods, they do not need an initial guess. However, these methods cost higher complexity and computation load with the increase in number of inverter levels. Hence, these methods cannot be used for harmonic elimination in higher level inverters applications.

Evolutionary computation algorithms have also been used to solve SHE equations due to their advantages of non-dependency on initial guess and ease of implementation. One of the earliest evolutionary algorithm, Genetic algorithm (GA) is applied to solve SHE equations in three phase nine level inverter [9]. It is reported that it takes more computational time and does not provide solutions even for some modulation indexes on which solution exists. In [10], bee algorithm is implemented for harmonic elimination in seven level inverter. It is reported that BA surpasses GA in terms of capability to find global solution and fast convergence rate but it is computationally complex. In [11], application of differential evolution is proposed for harmonic elimination in 15 level CHBMLI. In [12], authors proposed colonial competitive algorithm (CCA) for harmonic elimination in CHBMLI having equal and unequal DC sources and compared its performance with GA and PSO. Authors reported that CCA outperformed GA and PSO in terms of rate

of convergence. Application of generalized pattern search (GPS) is discussed for harmonic elimination in [13]. It is reported that for high level inverters where number of variables increase, GPS faces difficulty in computing solutions due to its feeble searching capability. In [14], application of particle swarm optimization (PSO) is reported for harmonic elimination in 5-level CHBMLI. Authors compared the performance of PSO with SPWM and reported that PSO performed superior than SPWM. In [15], species seed technique based PSO is produced. However, authors reported that this technique offers low rate of convergence because of the computation of Euclidean distance in each iteration. Application of memetic algorithm is discussed in [16]. It is reported that the computational complexity of this algorithm increases as the number of levels in inverter increase. In [17], authors discussed the application of water cycle algorithm (WCA) for elimination of fifth and seventh harmonic in three phase seven level inverter and compared its performance with PSO and FA. In the literature, less commonly used evolutionary algorithms such as differential search algorithm [18], whale optimization algorithm (WOA) [19], cuckoo search algorithm (CSA) [20] and modified grey wolf optimization (GWO) [21] are also proposed to solve SHE equations for harmonic elimination in multilevel inverters. Researchers have also developed hybrid based evolutionary algorithms to counter the drawbacks of conventional methods. The hybrid asynchronous particle swarm optimization-newton raphson (PSO-NR) is discussed in [22]. In [23] authors presented the method to improve the speed of convergence in which mesh adaptive direct search algorithm hybrid with the PSO algorithm. In [24] authors have presented a hybrid fish swarm optimization (FSO) for solving SHE equations in a reduced component based multilevel inverters in which PSO is hybrid with the fish swarm optimizer (FSO). In [25] application of asynchronous particle swarm optimization-genetic algorithm (APSO-GA) is discussed for harmonic elimination in single phase seven and nine-level inverters.

Among the aforementioned metaheuristic techniques, FA finds its popularity in finding good approximate to global solution for highly non-linear and non-convex objective functions [26]. The simple update criterion coupled with few tuning parameters make it convenient to implement FA for the non-convex and multi-modal problems. However, the canonical version of FA heavily relies on the exploitation behaviour of the fireflies. This can result in algorithm trapped at local optima and premature convergence of the algorithm for certain optimization functions. Therefore, several efforts have been made by the researchers in literature to introduce both social and cognitive components for the canonical FA. In this regard, the authors in [27] have suggested a hybrid firefly algorithm coupled with PSO to inherit the exploration properties of PSO. However, the hybridized structure presents additional complexity to implement the algorithm for large-scale optimization functions that require continuous equation update with hyper tuning of more parameters. Similarly, the authors in [28] presented a hybrid structure of

FA with PSO to solve computationally expensive problems. However, the presented structure again results in additional complexity with more tuning parameters. To introduce both exploration and exploitation components to FA with minimal complexity, the authors in [29] have suggested a multi-criteria search enhanced FA for finding the economic dispatch of multi-generation systems. The presented structure is efficient yet it lacks the balance of both social and cognitive components due to the static nature of the tuning parameters of both phases. To introduce global component to conventional FA, the authors in [30] and [31] have presented the hybrid structure of FA and accelerated PSO by introducing the single loop structure. However, the presented modification lacks the basic balance between both phases and does not provide the optimal performance for all objective functions.

B. RESEARCH GAP AND CONTRIBUTIONS

The majority implementations in the literature to introduce both the social and cognitive components for FA require complex hybridized structures and additional tuning parameters. The simple update criterion methods, which are used for introducing global component to FA, lacks the balance of social/cognitive components. Based on the above discussion, this research presents a simple updated search mechanism for FA with both exploitation and exploration properties to enhance the search capabilities of the canonical version of FA. Additionally, adaptively tuned parameters for social and cognitive parts of FA have been suggested to balance out the contribution of both phases. To summarize, following are the key contributions of this research:

- 1) A modified firefly algorithm with adaptive social and cognitive components is proposed for selective harmonic elimination problem in cascaded multi-level inverters by obtaining optimal switching angles.
- 2) The validation of modified firefly is performed on nine-level cascaded H-bridge inverters for varying modulation index values.
- 3) Experimental performance validation of modified firefly is also proved by implementation of nine-level cascaded H-bridge inverters results using OPAL-RT hardware setup.

The rest of the paper is organized as follows: Section II presents the overview of multi-level inverters. Section III presents the working of FA followed by discussion of the modified FA with adaptive social and cognitive components. Section IV presents methodology and results. The last section summarize the findings and future work.

II. MULTILEVEL INVERTER

A. CASCADED H - BRIDGE MULTILEVEL INVERTER

Cascaded H-bridge multilevel inverter (CHBMLI) consists of two or more H-bridge cells connected in series. For N level inverter, k number of DC sources or firing angles are required, where $k = \frac{N - 1}{2}$ and they can be equal or unequal. One H-bridge cell can produce $-V_{dc}$, 0 and $+V_{dc}$. The generalized

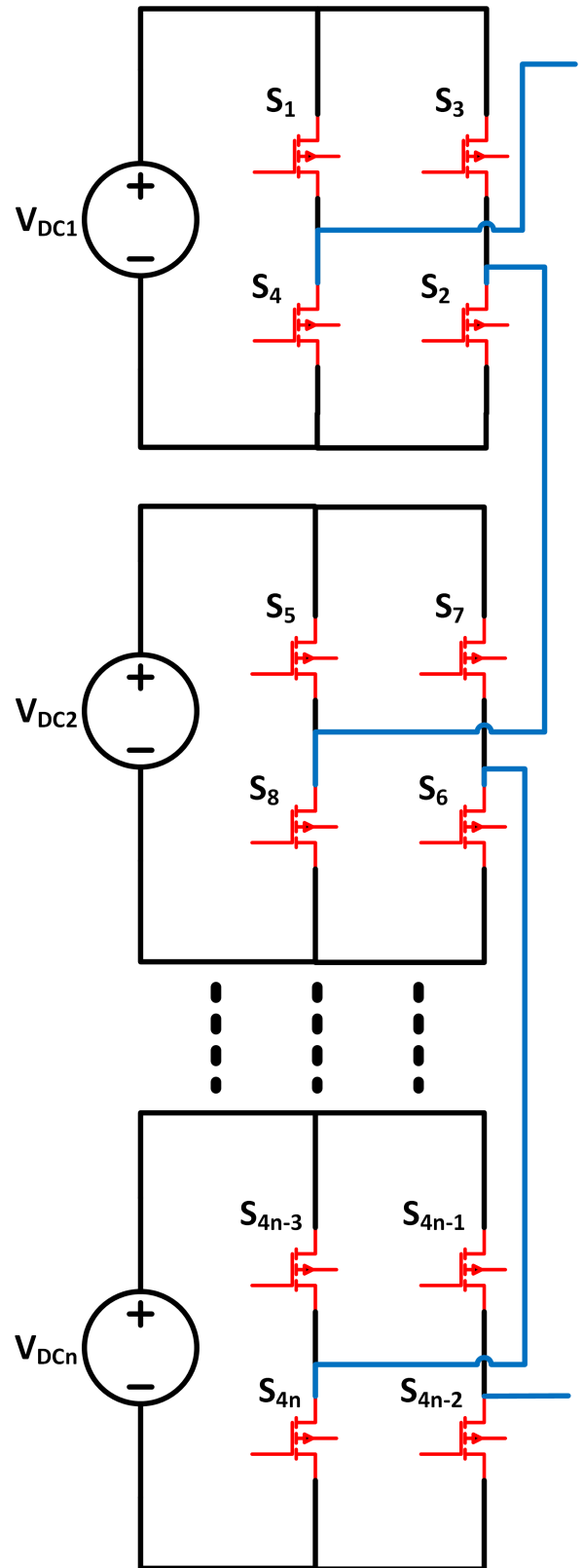

FIGURE 1. Generalized structure of cascaded H-bridge multilevel inverter.

structure of CHBMLI is shown in Figure.1. In the figure, n H-Bridges are connected in series having separate DC sources connected to them.

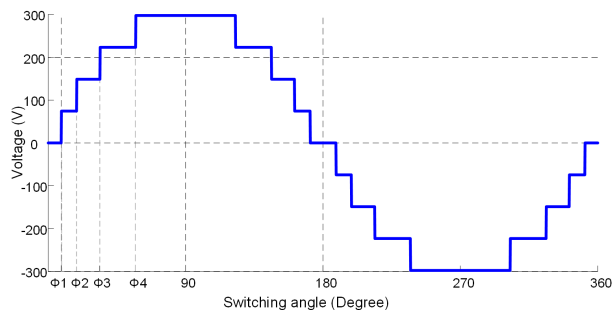

FIGURE 2. Staircase waveform of nine-level inverter.

B. SELECTIVE HARMONIC ELIMINATION PULSEWIDTH MODULATION

SHE equations of a three phase CHBMLI can be formulated by analyzing its phase voltage using Fourier series. Assuming a quarter wave symmetry, the even harmonics gets zero and cosine terms also become zero due to the odd nature of function. In the remaining of this paper, three-phase line-to-line voltage is referred as line voltage. Triplen harmonics are not considered while formulating SHE equations as they get cancelled out in line voltage.

For a N-level three phase CHBMLI comprising of k number of h-bridge cells, we can eliminate k-1 harmonics. SHE equations, comprising of fundamental and specific low order non-triplen harmonics, can be written as:

$$V_1 = \frac{4V_{dc}}{\pi} (\cos(\Phi_1) + \cos(\Phi_2) + \cos(\Phi_3) + \dots + \cos(\Phi_k)) \tag{1}$$

$$0 = \frac{4V_{dc}}{n\pi} (\cos(n\Phi_1) + \cos(n\Phi_2) + \cos(n\Phi_3) + \dots + \cos(n\Phi_k)) \tag{2}$$

We can write fundamental component in terms of modulation index (MI) as follows:

$$\cos(\Phi_1) + \cos(\Phi_2) + \cos(\Phi_3) + \dots + \cos(\Phi_k) = kMI = m_a \tag{3}$$

where,

$$MI = \frac{V_1}{\frac{4V_{dc}}{\pi}} \tag{4}$$

$$MI = \frac{V_1}{V_{max}} = \frac{V_1}{\frac{4kV_{dc}}{\pi}} = \frac{m_a}{k} \tag{5}$$

where, V_1 is the fundamental value of phase voltage obtained by H-bridge. V_{max} is the maximum value of phase voltage obtained by CHBMLI and k is no. of H-Bridge cells. V_{max} is obtained when all the switching angles are zero i.e.,

$$V_{max} = \frac{4kV_{dc}}{\pi} \tag{6}$$

The stepped level waveform for a 9-level CHBMLI is shown in Fig.2. Following the illustration and modeling,

we can write SHE equations for a 9-Level CHBMLI as:

$$\begin{aligned} \cos(\Phi_1) + \cos(\Phi_2) + \cos(\Phi_3) + \cos(\Phi_4) &= 4MI \\ &= m_a \end{aligned} \tag{7}$$

$$\cos(5\Phi_1) + \cos(5\Phi_2) + \cos(5\Phi_3) + \cos(5\Phi_4) = 0 \tag{8}$$

$$\cos(7\Phi_1) + \cos(7\Phi_2) + \cos(7\Phi_3) + \cos(7\Phi_4) = 0 \tag{9}$$

$$\cos(11\Phi_1) + \cos(11\Phi_2) + \cos(11\Phi_3) + \cos(11\Phi_4) = 0 \tag{10}$$

Equation 7 represents the fundamental component in terms of modulation index while Equations 8-10 represent equations for harmonics to be eliminated. Switching angles are obtained using the following objective function [25].

$$f = \min \left[\left| 100 \frac{U_d - U_1}{U_d} \right|^4 + \sum_{s=5}^S \frac{1}{h_s} \left| 50 \frac{U_{h_s}}{U_1} \right|^2 \right] \tag{11}$$

where, h_s represents the harmonic order, e.g., $h_2 = 3$ and $h_3 = 5$. U_1 is the value of fundamental voltage, and U_d is the desired fundamental voltage. To maintain the error between U_d and U_1 under 1% and to get the desired value of fundamental voltage, the first part of objective function is fined with the power of 4. Also, to keep the unwanted lower order harmonics under 2%, the second part of the fitness function is fine with the power of 2.

III. HEURISTIC OPTIMIZATION FOR SHE

The random nature of the heuristic optimization algorithms and their gradient-free approach make them convenient to implement for the non-linear, multi-modal, and non-convex optimization functions. The major parts of the heuristic techniques involve certain deterministic rules to explore/exploit the search space of the objective function along with a random component to avoid trapping to local minima. A large number of heuristic algorithms have been presented in literature to find the near optimal solution of complex objective functions [32], [33]. Among these different techniques, Firefly Algorithm (FA) is one of the popular methods to locate the near global solution of different optimization problems. This section presents the overview of the conventional FA and then presents the multi-update rule with adaptive social and cognitive components to enhance the search capabilities of the firefly algorithm.

A. FIREFLY ALGORITHM

FA works on the principle of the flashing phenomenon of the fireflies in nature. Each firefly of the population matrix constitutes a possible solution value for the given objective function. The number of the dimensions of each firefly are in accordance with the total decision variables of the objective function. The movement of the fireflies in the search space of the objective function is governed by the exploitation

component and the random part is controlled by a set of different tuning parameters. The light intensity/brightness of the fireflies correspond towards their fitness values. The fireflies having lower light intensity are shifted iteratively towards the brighter fireflies using a defined update equation [34], [35]. The light intensity of each firefly is defined by simple inverse square law which relates the intensity I_r with distance R from the source I_s as follows:

$$I_r = \frac{I_s}{R^2} \quad (12)$$

The intensity of the fireflies is influenced by the medium's absorption coefficient γ and it is modeled as:

$$I = I_o e^{-\gamma R} \quad (13)$$

where, I_o shows the intensity at $R = 0$ from the source. To avoid the singularity for (12) at $R = 0$, the above two relations can be combined as follows:

$$I = I_o e^{-\gamma R^2} \quad (14)$$

The attractiveness ϕ of each firefly directly relates with its intensity, therefore the (14) can be written as follows:

$$\phi = \phi_o e^{-\gamma R^2} \quad (15)$$

The distance term R in the above equation represents the Euclidean distance between the fireflies. For any two arbitrary fireflies $F_a \in \mathbb{R}^m$ and $F_b \in \mathbb{R}^m$ with m number of dimensions, the Euclidean distance [36] is given as follows:

$$R_{F_a F_b} = \sqrt{\sum_{j \in m} (F_{a,j} - F_{b,j})^2} \quad (16)$$

where, $F_{a,j}$ and $F_{b,j}$ show the j^{th} component of F_a and F_b . $R_{F_a F_b}$ represents the Euclidean distance between F_a and F_b . The FA update equation involves the movement model of firefly F_a towards the brighter firefly F_b in the given search space. This update equation can be automatically written as:

$$F_a^{k+1} = F_a^k + \underbrace{\phi_o e^{-\gamma R_{F_a F_b}^2} (F_b^k - F_a^k)}_{\text{Exploitation Component}} + \underbrace{\alpha(r - \frac{1}{2})}_{\text{Random Control}} \quad (17)$$

where, α controls the contribution of random component and its range is [0,1]. r shows the randomly generated number in the range [0,1]. Hence, the movement of the firefly F_a is influenced by both exploitation and random parts of the update equation. The next part of the section highlights the key drawback of the conventional update criterion for FA and then presents the modified FA with the simple addition of both exploration and exploitation phases [37].

B. MODIFIED FA WITH SOCIAL AND COGNITIVE COMPONENTS

The conventional FA compares the light intensity of different fireflies and shifts the fireflies having lower fitness value towards brighter fireflies. The update equation as defined

in (17) only exploits the neighbourhood of the brighter fireflies. The major drawbacks of the conventional FA is that it lacks the exploration phase, i.e, the movement of the fireflies towards the global component. This research proposes a simple update equation with both exploitation (cognitive component) and exploration (social) phases. The update equation for the firefly F_a towards the brighter firefly F_b with both social and cognitive components is given as follows:

$$F_a^{k+1} = F_a^k + \underbrace{c_1 \phi_o e^{-\gamma R_{F_a F_b}^2} (F_b^k - F_a^k)}_{\text{Exploitation Component}} + \underbrace{\alpha(r - \frac{1}{2})}_{\text{Random Control}} + \underbrace{c_2 \phi_o e^{-\gamma R_{F_a F_{g^*}}^2} (F_{g^*}^k - F_a^k)}_{\text{Exploration Component}} \quad (18)$$

where, c_1 and c_2 are the tuning parameters to control the influence of the exploitation and the exploration search of the firefly F_a respectively. c_1 and c_2 can be adjusted in the range of [0,1]. F_{g^*} represents the global value for a particular iteration k . $R_{F_a F_{g^*}}$ represents the Euclidean distance of the firefly F_a computed with respect to F_{g^*} . The distance term R for both components is given as follows:

$$R = \begin{cases} \sqrt{\sum_{j \in m} (F_{a,j} - F_{b,j})^2}, & \text{Exploitation Component} \\ \sqrt{\sum_{j \in m} (F_{a,j} - F_{g^*,j})^2}, & \text{Exploration Component} \end{cases} \quad (19)$$

The presented modification introduces both social and cognitive components and enhances the search capabilities of the conventional FA. The main idea is to influence the movement of the firefly F_a towards the global firefly F_{g^*} in addition to the F_b [29]. The next part of this section presents the adaptive nature of c_1 and c_2 to control different phases of the modified FA.

C. ADAPTIVE NATURE OF CONTROLLING PARAMETERS

For static c_1 and c_2 , the performance of the modified FA can be degraded. The next modification in the presented research is to make these parameters adaptive by introducing the time-based variations. The following relations describe the adaptiveness of c_1 and c_2 :

$$c_{1,p} = c_{1,l} + \frac{k}{k_{max}} (c_{1,u} - c_{1,l}) \quad (20)$$

$$c_{2,p} = c_{2,u} - \frac{k}{k_{max}} (c_{2,u} - c_{2,l}) \quad (21)$$

where, $c_{1,l}$ and $c_{1,u}$ represent the minimum and maximum values for exploitation controlling parameter. $c_{2,l}$ and $c_{2,u}$ represent the minimum and maximum values for exploration controlling parameter. $c_{1,p}$ and $c_{2,p}$ represent the adaptive tuning parameters. k_{max} represents the total number of iterations. Equation 20 shows a linearly increasing function for c_1 . At $k = k_{max}$, the modified firefly algorithm relies dominantly on the local search component, i.e, $c_1 = c_u$. Equation (21)

Algorithm 1 Pseudocode for Modified Firefly

```

1 Declare objective function  $f(\Phi_i)$ ;
2 Declare constants
3  $c_{1,l}, c_{1,u}, c_{2,l}, c_{2,u}, \beta_0, \alpha, \gamma, k_{max}, N$ ;
4 Randomly initialize Fireflies  $F$ ;
5 Evaluate Objective function value  $f(\Phi_i), \forall \Phi_i \in F$ ;
6 Rank the fireflies and find the initial global best
  firefly  $\Phi_g^*$ ;
7 while  $k < k_{max}$  do
8    $c_1 \leftarrow c_{1,l} + \frac{k}{k_{max}}(c_{1,u} - c_{1,l})$ ;
9    $c_2 \leftarrow c_{2,l} + \frac{k}{k_{max}}(c_{2,u} - c_{2,l})$ ;
10  for  $i \leftarrow 1$  to  $N$  do
11    for  $j \leftarrow 1$  to  $N$  do
12      Find Exploitation distance  $R_{ij}$  using
        distance relation;
13      Find Exploration distance  $R_{ig}^*$  using
        distance relation;
14      if  $I_j > I_i$  then
15         $\Phi_i \leftarrow \Phi_i + c_1 \beta_0 \exp^{-\gamma R_{ij}^2} (\Phi_j - \Phi_i) +$ 
           $c_2 \beta_0 \exp^{-\gamma R_{ig}^{*2}} (\Phi_g^* - \Phi_i) +$ 
           $\alpha(\text{rand}() - 0.5)$ ;
16      if  $I_i > I_j$  then
17         $\Phi_i \leftarrow \Phi_i + c_2 \beta_0 \exp^{-\gamma R_{ig}^{*2}} (\Phi_g^* -$ 
           $\Phi_i) + \alpha(\text{rand}() - 0.5)$ ;
18    Evaluate Objective function value  $f(\Phi_i)$  at updated
       $\Phi_i, \forall \Phi_i \in F$ ;
19    Rank the fireflies and determine the global best
       $\Phi_g^*$  at updated  $\Phi_i$ ;
20     $k \leftarrow k + 1$ ;

```

TABLE 1. Modified Firefly based SHEPWM parameters for 9-level CHBMLI.

Parameters	
Voltage levels	9
Maximum attainable voltage	$4V_{DC}$
No. of switching angles	4
No. of harmonics to be eliminated	3
No. of iterations	100
Population size	20
Absorption co-efficient	1
Attractiveness co-efficient	1
Randomization co-efficient	0.5
c_{1max}, c_{1min}	1, 0.1
c_{2max}, c_{2min}	1, 0

shows a linearly decreasing function for exploration controlling parameter. At $k = k_{max}$, the modified firefly algorithm minimizes the global search, i.e., $c_2 = c_1$. The presented adaptive parameters ensure that the algorithm explores the neighbourhood of the firefly having lower intensity to avoid the local trapping at the start of the search process. Similarly, the adaptive c_1 ensures that the algorithm exploits locally to avoid possible oscillation around the optimal solution when

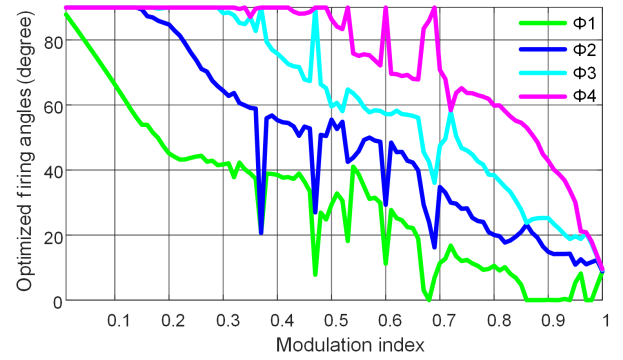
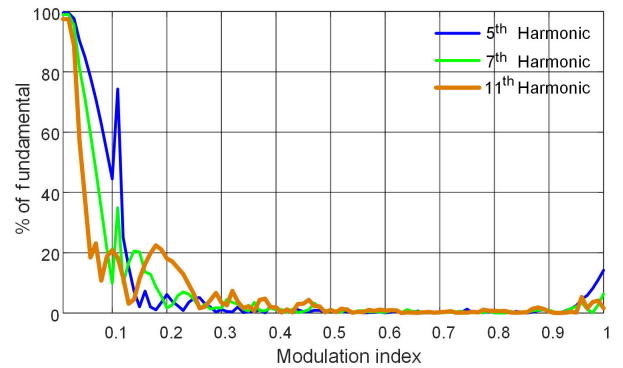
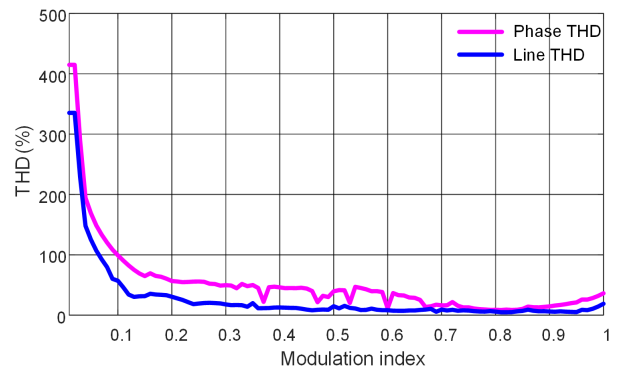

FIGURE 3. Optimized switching angles under various modulation indices.

(a) Percentage of eliminated harmonics under various modulation indexes

(b) THD under various modulation indexes

FIGURE 4. Harmonics and THD under various modulation indexes.

reaching towards convergence [38]. The overall update equation with adaptive c_1 and c_2 is given as follows:

$$\begin{aligned}
 F_a^{k+1} = & F_a^k + \underbrace{c_1 \phi_o e^{-\gamma R_{fa}^2} (F_b^k - F_a^k)}_{\text{Adaptive Exploitation Component}} + \underbrace{\alpha(r - \frac{1}{2})}_{\text{Random Control}} \\
 & + \underbrace{c_2 \phi_o e^{-\gamma R_{fa}^2} (F_g^{*k} - F_a^k)}_{\text{Adaptive Exploration Component}} \quad (22)
 \end{aligned}$$

The adaptive nature of c_1 and c_2 along with both the exploration and exploitation components enhance the search capabilities of the conventional FA. The MFA pseudocode for solving SHE optimization problem is given in Algorithm 1.

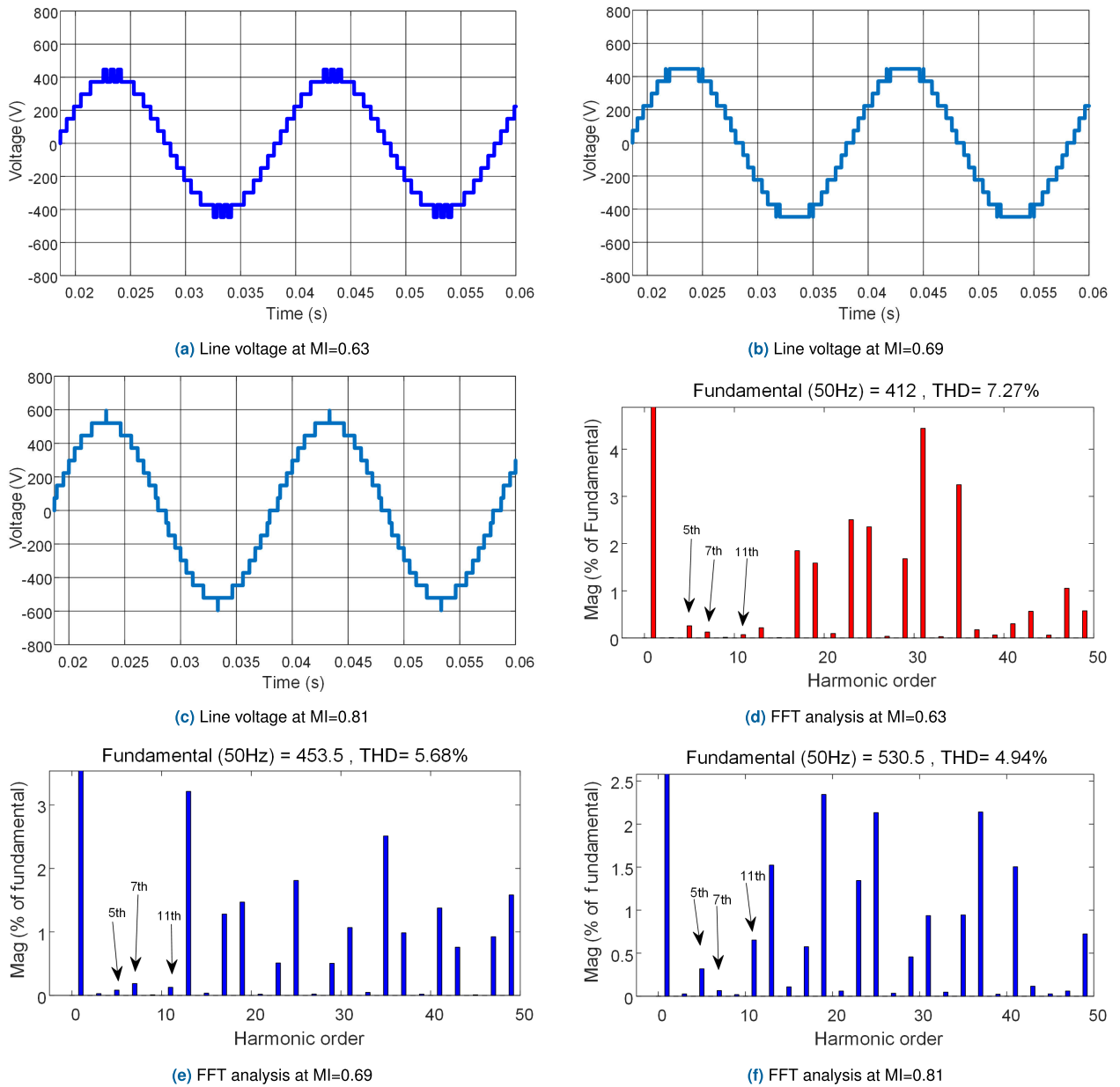

FIGURE 5. Line Voltages and FFT Analysis Graphs obtained at various modulation indexes.

IV. RESULTS AND DISCUSSION

The proposed MFA algorithm is implemented in MATLAB to obtain the optimized switching angles for SHE of CHBMLI. The crucial parameters required for optimization are given in Table.1. CHBMLI is connected to the resistor of value 10 Ω for simulation and experimental analysis.

A. SIMULATION RESULTS

The switching angles are obtained for nine level inverter having equal DC source over modulation index range $0 \leq MI \leq 1$ with the increment size of 0.01. The optimized switching angles obtained are shown in Fig. 3.

where, ϕ_1, ϕ_2, ϕ_3 and ϕ_4 represent the optimized switching angles. To carry out simulation, nine level CHBMLI having DC source of 75V connected to each H-bridge cell is simulated in Simulink. Maximum voltage that can be generated by MLI is 300V. Fast Fourier transform (FFT) tool is used to perform harmonic analysis to analyze the effects of obtained switching angles on the THD. The effect of obtained switching angles on the eliminated harmonics and THD is shown in Fig. 4.

By looking at Fig. 4 (a), it can be observed that for modulation index range 0.1 to 0.2, targeted harmonics could not be eliminated and for modulation index range 0.4 to 0.9, amplitude of targeted harmonics is negligible i.e., they have been

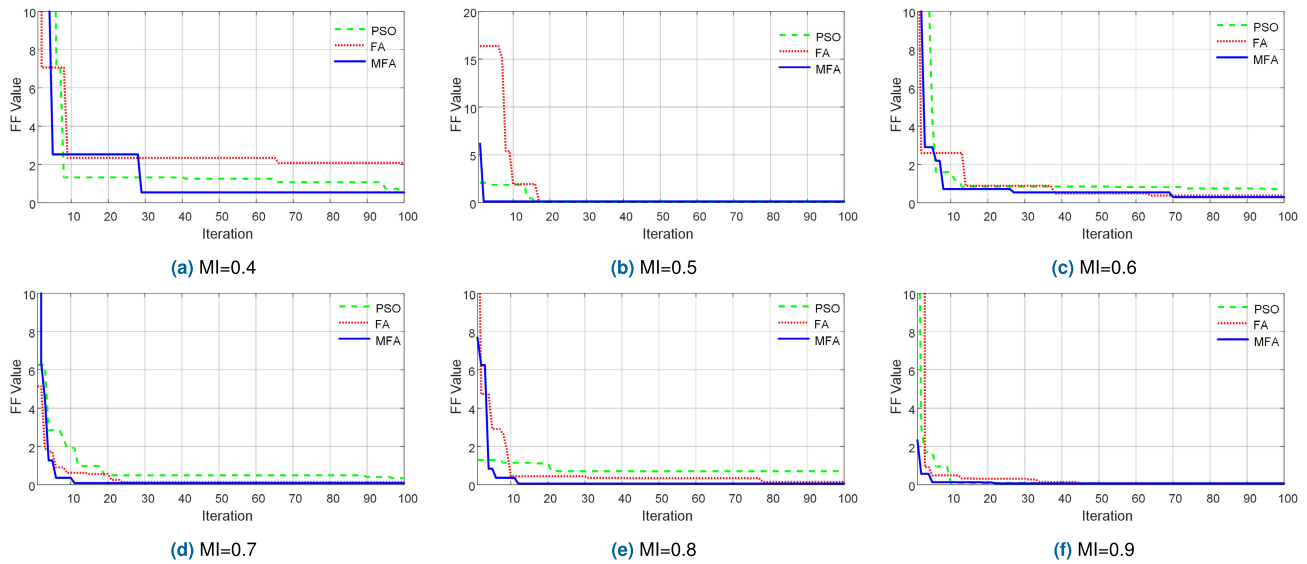

FIGURE 6. Convergence graphs at different modulation indexes.

TABLE 2. THD Comparison between different algorithms.

Modulation Index	THD		
	PSO	FA	MFA
0.3	18.56	19.33	17.8
0.4	12.8	12.83	12.8
0.5	8.86	8.9	8.9
0.6	8	8.56	7.86
0.63	7.27	7.26	7.23
0.7	7.96	7.8	7.47
0.8	5.93	5.90	5.90
0.81	4.93	5.3	4.68

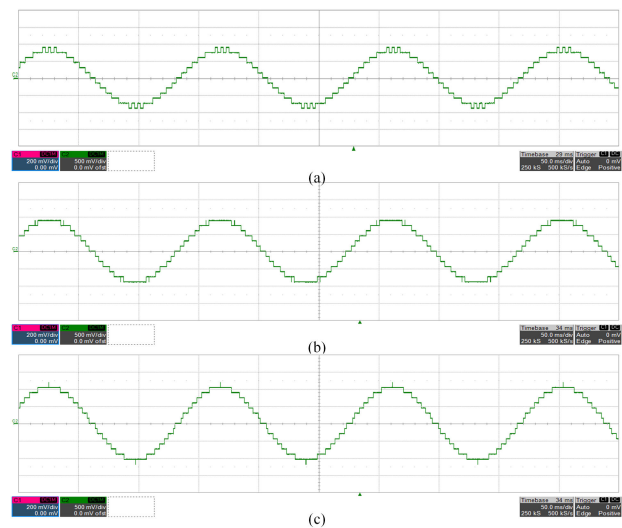

FIGURE 8. Experimental results of line voltages at (a) MI=0.63, (b) MI=0.69, and (c) MI=0.81.

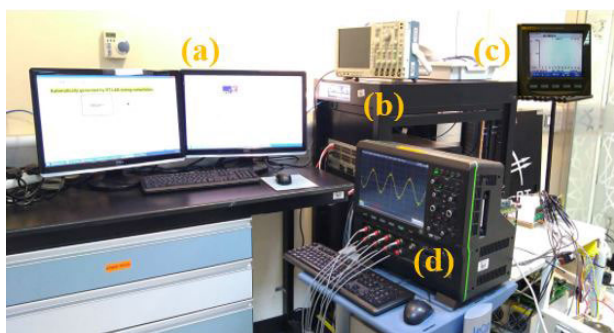

FIGURE 7. Experimental Setup: (a) RT Lab software (b) Op5700 OPAL-RT (c) Fluke 435 power quality analyzer (d) Lacrocy MDA 810 oscilloscope.

completely eliminated. The simulated output line voltages and harmonic spectrums of the line voltages of the 9-level CHBMLI are shown in Fig. 5 under 3 different modulation indexes. It can be observed that in all the three instances, the SHEPWM eliminated the 5th, 7th and 11th order harmonics effectively as shown in Fig. 5.

The advantageous and predominant characteristics of the proposed optimization algorithms are validated by comparing it with other algorithms that have already been applied in

SHEPWM. The comparative analysis is conducted considering two major targets: the calculated THD and the convergence behaviour of the algorithms. The proposed algorithm is compared with two other algorithms which are named as firefly (FA) and particle swarm optimization (PSO). To justify the comparison, the same parameters such as number of iterations, population size are considered for all the algorithms. We can see from Table. 2, for some modulation index values all the algorithms have produced same values of THD. At modulation index values of 0.3, 0.6 and 0.7, the THD attained by the proposed algorithm is less than than the PSO and FA. This proves the prominence of the proposed algorithm. The convergence graphs corresponding

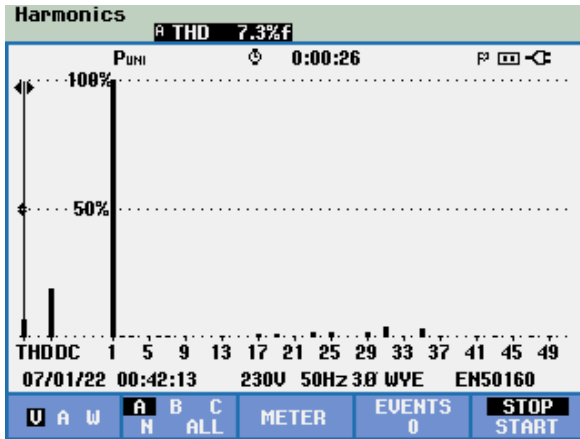

FIGURE 9. Line THD at MI=0.63.

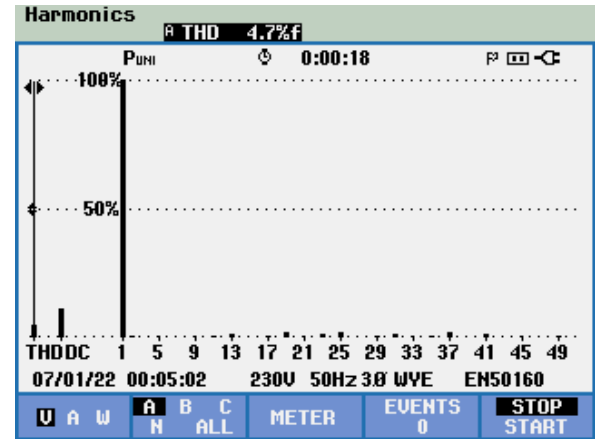

FIGURE 11. Line THD at MI=0.81.

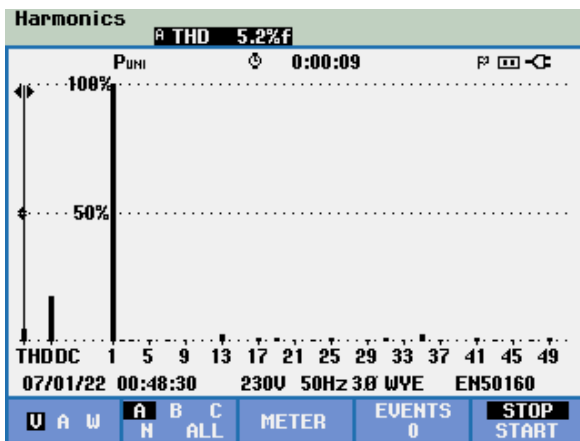

FIGURE 10. Line THD at MI=0.69.

to various modulation indexes are shown in Fig. 6. It can be observed from the convergence graphs that the proposed algorithm has attained lower fitness value than PSO and FA against large range of modulation index which shows its higher accuracy. Moreover, it has converged to the optimal solution with reduced iterations than PSO and FA.

B. EXPERIMENTAL RESULTS

The results obtained through simulation are further verified by conducting an experimental analysis. The experimental setup consists of real time hardware setup of Op5700 OPAL-RT system, Fluke 435 power quality analyzer and Lecroy MDA 810 oscilloscope. The experimental setup is presented in Fig. 7 for performance validation of proposed algorithm. The phase and line voltage waveforms corresponding to modulation index values of 0.63, 0.68 and 0.81 are shown in Fig. 8. The waveforms obtained are analyzed using Fluke 435 power quality analyzer to observe the percentages of eliminated harmonic components and total harmonic distortion.

Figures 9, 10 and 11 show the harmonic spectrum obtained at above mentioned modulation indexes using power analyzer of the line voltage waveforms. The experimental results

clearly show that the targeted harmonics have been eliminated and consequently THD has also been noticeably reduced. At MI = 0.63, line THD reaches at 7.3% and it further reduces to 5.2% at MI = 0.69. While, Line THD has been able to attain the minimal value of 4.7% at MI = 0.8.

V. CONCLUSION

The modified firefly based on multi-criteria search is proposed to solve SHE equations to eliminate harmonics in a cascaded H-bridge multi-level inverter. The effectiveness of the proposed algorithm is tested using both simulation and real-time OPAL - RT based experimental prototype of three-phase nine-level cascaded H-bridge inverter. The developed algorithm showed promising results than particle swarm optimization and conventional firefly algorithms in terms of both speed of convergence and reduced THD for different modulation indexes. Finally, the experimental results for a 9-level cascaded H-bridge inverter validated the accuracy of the multi-criteria search-based modified firefly algorithm. In future, application of proposed algorithm can be applied for solving selective harmonic eliminations in higher level inverters having more number of switching angles.

ACKNOWLEDGMENT

Sheroze Liaquat thanks the Higher Education Commission, Pakistan, for providing him an academic scholarship to pursue the Ph.D. degree at the Department of Electrical Engineering and Computer Science South Dakota State University, Brookings, USA, under the US-Pakistan Knowledge Corridor program.

REFERENCES

- [1] A. Poorfakhraei, M. Narimani, and A. Emadi, "A review of multilevel inverter topologies in electric vehicles: Current status and future trends," *IEEE Open J. Power Electron.*, vol. 2, pp. 155–170, 2021.
- [2] M. V. Rajkumar, P. S. Manoharan, and A. Ravi, "Simulation and an experimental investigation of SVPWM technique on a multilevel voltage source inverter for photovoltaic systems," *Int. J. Electr. Power Energy Syst.*, vol. 52, pp. 116–131, Nov. 2013.
- [3] V. Fernão Pires, J. Fialho, and J. F. Silva, "HVDC transmission system using multilevel power converters based on dual three-phase two-level inverters," *Int. J. Electr. Power Energy Syst.*, vol. 65, pp. 191–200, Feb. 2015.

- [4] S. N. Duarte, P. M. de Almeida, and P. G. Barbosa, "A novel energizing strategy for a grid-connected modular multilevel converter operating as static synchronous compensator," *Int. J. Electr. Power Energy Syst.*, vol. 109, pp. 672–684, Jul. 2019.
- [5] P. Kumar, M. Kour, S. K. Goyal, and B. P. Singh, "Multilevel inverter topologies in renewable energy applications," in *Intelligent Computing Techniques for Smart Energy Systems*. Cham, Switzerland: Springer, 2020, pp. 891–902.
- [6] M. S. A. Dahidah, G. Konstantinou, and V. G. Agelidis, "A review of multilevel selective harmonic elimination PWM: Formulations, solving algorithms, implementation and applications," *IEEE Trans. Power Electron.*, vol. 30, no. 8, pp. 4091–4106, Aug. 2015.
- [7] J. Sun, S. Beineke, and H. Grotstollen, "Optimal PWM based on real-time solution of harmonic elimination equations," *IEEE Trans. Power Electron.*, vol. 11, no. 4, pp. 612–621, Jul. 1996.
- [8] J. Chiasson, L. M. Tolbert, K. McKenzie, and Z. Du, "A complete solution to the harmonic elimination problem," in *Proc. 18th Annu. IEEE Appl. Power Electron. Conf. Expo.*, Feb. 2003, pp. 596–602.
- [9] R. Salehi, N. Farokhnia, M. Abedi, and S. H. Fathi, "Elimination of low order harmonics in multilevel inverters using genetic algorithm," *J. Power Electron.*, vol. 11, no. 2, pp. 132–139, Mar. 2011.
- [10] A. Kavousi, B. Vahidi, R. Salehi, M. K. Bakhshizadeh, N. Farokhnia, and S. H. Fathi, "Application of the bee algorithm for selective harmonic elimination strategy in multilevel inverters," *IEEE Trans. Power Electron.*, vol. 27, no. 4, pp. 1689–1696, Apr. 2012.
- [11] Z. Salam, A. Majed, and A. M. Amjad, "Design and implementation of 15-level cascaded multi-level voltage source inverter with harmonics elimination pulse-width modulation using differential evolution method," *IET Power Electron.*, vol. 8, no. 9, pp. 1740–1748, Sep. 2015.
- [12] M. H. Etesami, N. Farokhnia, and S. H. Fathi, "Colonial competitive algorithm development toward harmonic minimization in multilevel inverters," *IEEE Trans. Ind. Informat.*, vol. 11, no. 2, pp. 459–466, Apr. 2015.
- [13] K. Haghdar and H. A. Shayanfar, "Selective harmonic elimination with optimal DC sources in multilevel inverters using generalized pattern search," *IEEE Trans. Ind. Informat.*, vol. 14, no. 7, pp. 3124–3131, Jul. 2018.
- [14] V. K. Gupta and R. Mahanty, "Optimized switching scheme of cascaded H-bridge multilevel inverter using PSO," *Int. J. Electr. Power Energy Syst.*, vol. 64, pp. 699–707, Jan. 2015.
- [15] M. T. Hagh, H. Taghizadeh, and K. Razi, "Harmonic minimization in multilevel inverters using modified species-based particle swarm optimization," *IEEE Trans. Power Electron.*, vol. 24, no. 10, pp. 2259–2267, Oct. 2009.
- [16] A. N. Kumle, S. H. Fathi, F. Jabbarvaziri, M. Jamshidi, and S. S. H. Yazdi, "Application of memetic algorithm for selective harmonic elimination in multi-level inverters," *IET Power Electron.*, vol. 8, no. 9, pp. 1733–1739, 2015.
- [17] M. Khizer, U. T. Shami, M. F. Zia, Y. Amirat, and M. Benbouzid, "Selective harmonic elimination in a cascaded multilevel inverter of distributed power generators using water cycle algorithm," *Machines*, vol. 10, no. 5, p. 399, May 2022.
- [18] S. Kundu, A. D. Burman, S. K. Giri, S. Mukherjee, and S. Banerjee, "Comparative study between different optimisation techniques for finding precise switching angle for SHE-PWM of three-phase seven-level cascaded H-bridge inverter," *IET Power Electron.*, vol. 11, no. 3, pp. 600–609, Mar. 2018.
- [19] P. Kumar Kar, A. Priyadarshi, and S. Bhaskar Karanki, "Selective harmonics elimination using whale optimisation algorithm for a single-phase-modified source switched multilevel inverter," *IET Power Electron.*, vol. 12, no. 8, pp. 1952–1963, Jul. 2019.
- [20] A. Ajami, B. Mohammadzadeh, and M. R. J. Oskuee, "Utilizing the cuckoo optimization algorithm for selective harmonic elimination strategy in the cascaded multilevel inverter," *ECTI Trans. Electr. Eng., Electron., Commun.*, vol. 12, no. 1, pp. 7–15, 2014.
- [21] A. Routray, R. K. Singh, and R. Mahanty, "Harmonic reduction in hybrid cascaded multilevel inverter using modified grey wolf optimization," *IEEE Trans. Ind. Appl.*, vol. 56, no. 2, pp. 1827–1838, Mar. 2020.
- [22] K. Shen, D. Zhao, J. Mei, L. M. Tolbert, J. Wang, M. Ban, Y. Ji, and X. Cai, "Elimination of harmonics in a modular multilevel converter using particle swarm optimization-based staircase modulation strategy," *IEEE Trans. Ind. Electron.*, vol. 61, no. 10, pp. 5311–5322, Oct. 2014.
- [23] A. Routray, R. Kumar Singh, and R. Mahanty, "Harmonic minimization in three-phase hybrid cascaded multilevel inverter using modified particle swarm optimization," *IEEE Trans. Ind. Informat.*, vol. 15, no. 8, pp. 4407–4417, Aug. 2019.
- [24] K. P. Panda, S. S. Lee, and G. Panda, "Reduced switch cascaded multilevel inverter with new selective harmonic elimination control for standalone renewable energy system," *IEEE Trans. Ind. Appl.*, vol. 55, no. 6, pp. 7561–7574, Nov. 2019.
- [25] M. A. Memon, M. D. Siddique, S. Mekhilef, and M. Mubin, "Asynchronous particle swarm optimization-genetic algorithm (APSO-GA) based selective harmonic elimination in a cascaded H-bridge multilevel inverter," *IEEE Trans. Ind. Electron.*, vol. 69, no. 2, pp. 1477–1487, Feb. 2022.
- [26] B. Khan and P. Singh, "Selecting a meta-heuristic technique for smart micro-grid optimization problem: A comprehensive analysis," *IEEE Access*, vol. 5, pp. 13951–13977, 2017.
- [27] P. Kora and K. S. R. Krishna, "Hybrid firefly and particle swarm optimization algorithm for the detection of bundle branch block," *Int. J. Cardiovascular Acad.*, vol. 2, no. 1, pp. 44–48, Mar. 2016.
- [28] I. B. Aydilek, "A hybrid firefly and particle swarm optimization algorithm for computationally expensive numerical problems," *Appl. Soft Comput.*, vol. 66, pp. 232–249, May 2018.
- [29] S. Liaquat, M. S. Fakhar, S. A. R. Kashif, A. Rasool, O. Saleem, M. F. Zia, and S. Padmanaban, "Application of dynamically search space squeezed modified firefly algorithm to a novel short term economic dispatch of multi-generation systems," *IEEE Access*, vol. 9, pp. 1918–1939, 2021.
- [30] S. Liaquat, O. Saleem, and K. Azeem, "Comparison of firefly and hybrid firefly-APSO algorithm for power economic dispatch problem," in *Proc. Int. Conf. Technol. Policy Energy Electric Power (ICT-PEP)*, Sep. 2020, pp. 94–99.
- [31] S. Liaquat, M. S. Fakhar, S. A. R. Kashif, and O. Saleem, "Statistical analysis of accelerated PSO, firefly and enhanced firefly for economic dispatch problem," in *Proc. 6th Int. Conf. Renew. Energy, Gener. Appl. (ICREGA)*, Feb. 2021, pp. 106–111.
- [32] K. Hussain, M. N. Mohd Salleh, S. Cheng, and Y. Shi, "Metaheuristic research: A comprehensive survey," *Artif. Intell. Rev.*, vol. 52, no. 4, pp. 2191–2233, Dec. 2019.
- [33] Z. T. Allawi, I. K. Ibraheem, and A. J. Humaidi, "Fine-tuning meta-heuristic algorithm for global optimization," *Processes*, vol. 7, no. 10, p. 657, Sep. 2019.
- [34] X.-S. Yang and A. Slowik, "Firefly algorithm," in *Swarm Intelligence Algorithms*. Boca Raton, FL, USA: CRC Press, 2020, pp. 163–174.
- [35] S. Liaquat, M. F. Zia, O. Saleem, Z. Asif, and M. Benbouzid, "Performance analysis of distance metrics on the exploitation properties and convergence behaviour of the conventional firefly algorithm," *Appl. Soft Comput.*, vol. 126, Sep. 2022, Art. no. 109255.
- [36] M. J. Gordanloo and F. S. Gharehchopogh, "A hybrid OBL-based firefly algorithm with symbiotic organisms search algorithm for solving continuous optimization problems," *J. Supercomput.*, vol. 78, no. 3, pp. 3998–4031, Feb. 2022.
- [37] S. Liaquat, M. S. Fakhar, S. A. R. Kashif, A. Rasool, O. Saleem, and S. Padmanaban, "Performance analysis of APSO and firefly algorithm for short term optimal scheduling of multi-generation hybrid energy system," *IEEE Access*, vol. 8, pp. 177549–177569, 2020.
- [38] V. Kumar and D. Kumar, "A systematic review on firefly algorithm: Past, present, and future," *Arch. Comput. Methods Eng.*, vol. 28, no. 4, pp. 3269–3291, Jun. 2021.



MUHAMMAD KHIZER received the B.Sc. and M.Sc. degrees in electrical engineering with the specialization in power systems from the University of Engineering and Technology, Lahore. His current research interests include meta-heuristics algorithms and their applications in power electronics.



SHEROZE LIAQUAT (Graduate Student Member, IEEE) received the B.Sc. and M.Sc. degrees in electrical engineering with specialization in power systems from the University of Engineering and Technology, Lahore, Pakistan, in 2018 and 2020, respectively. He is currently pursuing the Ph.D. degree with the Electrical Engineering and Computer Science Department, South Dakota State University, USA. He served as the Faculty Member with the Electrical Engineering Department, National University of Computer and Emerging Sciences, Lahore, from 2018 to 2021. His current research interests include the application of meta-heuristic techniques, soft computing methods, machine learning algorithms in the economic dispatch problem, and electricity markets.



MUHAMMAD FAHAD ZIA (Member, IEEE) received the Ph.D. degree in electrical engineering from the University of Brest, Brest, France, in 2020. His main research interests and experience include ac/dc microgrids, energy management systems, transactive energy, power system operation, and power electronics. He is serving as a Reviewer for many prestigious journals from IEEE, IET, Elsevier, MPDI, and other publishers, including IEEE TRANSACTIONS ON SMART GRID, IEEE TRANSACTIONS ON SYSTEMS, MAN, AND CYBERNETICS: SYSTEMS, IEEE TRANSACTIONS ON INDUSTRY APPLICATIONS, *Applied Energy*, *Electric Power Systems Research*, *IET Renewable Power Generation*, *IET Generation, Transmission and Distribution*, *Energies*, and *Electronics* among others. He is also a Topic Editor for *MDPI Electronics*.



SAIKRISHNA KANUKOLLU received the B.Tech. degree in electrical and electronics engineering from Jawaharlal Nehru Technological University, Hyderabad, India, in 2008, and the M.Tech. degree in power electronics and power systems from the Indian Institute of Technology Bombay, Mumbai, India, in 2010. In 2010, he joined ABB, India, as an Application Engineer, where he was involved in the development of a SCADA network management tool for power systems. He joined The Petroleum Institute, Abu Dhabi, UAE (currently Khalifa University), in 2011, as a Research Engineer. At Khalifa University, he has been serving in several research capacities, including executing various research projects related to power electronics applications in oil and gas industry, power systems, and constructing experimental setups (power electronics, motor drives, renewable energy systems, and grounding systems). His research interests include microgrid systems, renewable energy systems, operation and control of high-density power electronic converters, and electric motor drives.



AHMED AL-DURRA (Senior Member, IEEE) received the Ph.D. degree in ECE from The Ohio State University, in 2010. He is currently a Professor with the EECs Department, Khalifa University, United Arab Emirates. He has supervised/co-supervised over 30 Ph.D./master's students. He is also leading the Energy Systems Control and Optimization Laboratory, Advanced Power and Energy Center. He has one U.S. patent, one edited book, 12 book chapters, and over 230 scientific papers in top-tier journals and refereed international conference proceedings. His research interests include applications of control and estimation theory on power systems stability, micro and smart grids, renewable energy systems and integration, and process control. He is an Editor of IEEE TRANSACTIONS ON SUSTAINABLE ENERGY and IEEE POWER ENGINEERING LETTERS; and an Associate Editor of IEEE TRANSACTIONS ON INDUSTRY APPLICATIONS, *IET Renewable Power Generation*, and *Frontiers in Energy Research*.



S. M. MUYEEN (Senior Member, IEEE) received the B.Sc.Eng. degree from the Rajshahi University of Engineering and Technology (RUET), Bangladesh (formerly known as Rajshahi Institute of Technology), in 2000, and the M.Eng. and Ph.D. degrees from the Kitami Institute of Technology, Japan, in 2005 and 2008, respectively, all in electrical and electronic engineering. He is currently a Full Professor at the Electrical Engineering Department, Qatar University. He has published more than 350 articles in different journals and international conferences. He has published seven books as the author or an editor. His research interests include power system stability and control, electrical machine, FACTS, energy storage systems (ESS), renewable energy, and HVDC systems. He has been a keynote speaker and an invited speaker at many international conferences, workshops, and universities. He is serving as an Editor/an Associate Editor for many prestigious journals from IEEE, IET, and other publishers, including IEEE TRANSACTIONS ON ENERGY CONVERSION, IEEE POWER ENGINEERING LETTERS, *IET Renewable Power Generation*, and *IET Generation, Transmission and Distribution*. He is a Chartered Professional Engineer, Australia, and a fellow of Engineers Australia.

...