

Received 26 October 2017; revised 17 April 2018; accepted 14 May 2018. Date of publication 28 May 2018;  
date of current version 4 June 2018.

Digital Object Identifier 10.1109/JTEHM.2018.2838139

# A Novel System to Measure Infants' Nutritive Sucking During Breastfeeding: the Breastfeeding Diagnostic Device (BDD)

LONGTU CHEN<sup>1</sup>, RUTH F. LUCAS<sup>2</sup>, AND BIN FENG<sup>1</sup>

<sup>1</sup>Biomedical Engineering Department, University of Connecticut, Storrs, CT 06269, USA

<sup>2</sup>School of Nursing, University of Connecticut, Storrs, CT 06269, USA

CORRESPONDING AUTHOR: B. FENG (fengb@uconn.edu)

This work was supported by the Connecticut Bio Pipeline Grant.

**ABSTRACT** Breastfeeding is optimal for infant health, but more than 66% of mothers cease exclusive breastfeeding within three months after giving birth. Evaluating infants' sucking effort provides valuable diagnosis to mothers encountering barriers with breastfeeding. Sucking microstructure is defined as an array of metrics that comprehensively capture infants' ability to create a sealed latch onto mother's nipple and regulate feeding, including number of sucks, sucks per burst, number of bursts, intra suck interval, and maximal sucking pressure. In this paper, we proposed a breastfeeding diagnostic device (BDD) which allows convenient and objective measurement of infants' sucking microstructure in both home and clinical settings. BDD utilizes an air-based pressure transducer to measure infants' sucking behavior. We conducted pilot clinical studies on six dyads of mother and infant to test the feasibility of the BDD system. To facilitate comparison, both breastfeeding and bottle-feeding were conducted on the six dyads using the BDD in home settings, and the outcomes are comparable with prior recordings in research or clinical settings. By offering a convenient and objective measurement of the sucking microstructure, the BDD will provide clinically meaningful guidance and diagnosis to mothers struggling with breastfeeding. BDD will also serve as an objective metric useful in research areas relevant to infant behaviors, assessment of neurodevelopment, and potentially a screening tool for developmental disabilities.

**INDEX TERMS** Pressure transducer, sucking microstructure, breastfeeding, bottle-feeding, infant behavior.

## I. INTRODUCTION

Breastfeeding after delivery is initiated by 81% of mother-infant dyads [1]. The evidence is clear that breastfeeding is optimal for infant health in preventing illness during the first year of life, especially lifelong disease such as type 2 diabetes, promoting mother-infant attachment, and enhancing cognitive development [2], [3]. However, more than 66% of mothers cease exclusive breastfeeding and begin supplementation with formula and bottle-feeding within 3 months after giving birth [4]–[7]. This rapid drop of exclusive breast feeding rate is due to common issues of early breastfeeding: maternal perception of poor milk supply, and infants' inability to latch and sustain sucking [8], [9]. These two problems are interrelated as a poor infant latch and suck will not stimulate the breast and the neurohormonal cascade for milk regulation thus affecting ongoing milk supply [10], [11].

To assist mothers encountering barriers with direct breastfeeding, lactation professionals offer guidance by asking mothers about infants' effort at the breast and observing a breastfeeding session [12], [13]. However, there is limited options to objectively measure infants' effort, such as number of sucks, or changes in intraoral pressure during direct breastfeeding in the clinical and home settings [14]–[16]. In clinical and research settings, infants' efforts are objectively measured by infants' sucking microstructure, i.e., an array of metrics that comprehensively capture infants' ability to create a sealed latch and regulate feeding over time: number of sucks, sucks per burst, number of bursts, intra suck interval, and average maximal sucking pressure [17]–[19]. Thus, measurement of the sucking microstructure can effectively capture the infants' efforts during feeding sessions.

Infants' sucking during breastfeeding involves the interaction of several facial muscles, including the masseter, temporal, orbicular, and suprahyoid muscles to promote the regulative movement of mandible, palate and tongue during oral feeding [20]. Current methods to measure the sucking microstructure in infants can be categorized into four groups that target 1) orofacial motion, 2) oral chamber geometry, 3) muscle activities, and 4) intraoral pressure. Infants' orofacial motion has been widely captured by camera video recording of breastfeeding aided by markers placed at the lateral angle of the eye, the tip of the jaw, and the throat region. Information like regional movement at the jaw and throat and the mouth angle can be extracted by analyzing the videos post-hoc [21]. More recently, feature tracking based video analysis was utilized to capture the infant sucking behavior to estimate sucking counts [22]. However, videotaping can be inaccurate and cannot reveal metrics relevant to intraoral pressure, which are critical components of the sucking microstructure [23]. Infants' oral chamber geometry during breastfeeding is measured by ultrasound that illustrates the movement of anterior and posterior tongue, palate, nipple-areola complex and their relations during feeding process [15], [24]–[27]. Ultrasound effectively measures many parameters of sucking microstructure especially those relevant to intraoral chamber geometry and contributes to a clinical algorithm of detecting swallowing and sucking events as well as discriminating peristaltic and vacuum tongue action, but cannot measure intraoral pressure and is limited as a clinical tool in hospital settings [28]. Facial muscle activities during breastfeeding are measured by surface electromyogram (sEMG), which provides quantitative measures of muscle forces from which sucking microstructures are derived [29], [30]. The sEMG method allows indirect measurement of sucking motions but also does not permit recordings of intraoral pressure. Lastly, temporal recording of intraoral pressure appears to be the only means to allow the complete capture of the sucking microstructure. Intraoral pressure in infants were reportedly captured during bottle-feeding by several research groups via a customized

feeding bottle with an embedded pressure sensor [31]–[36]. More recently, studies have been performed to evaluate contacting force applied by infant tongue to nipple and coordination of sucking, swallowing and breathing during bottle-feeding [37]–[40]. In contrast, studies that measure intraoral pressure during breast feeding are scarce. Three experimental studies which measured changes in intraoral pressure during breastfeeding unanimously used fluid-filled catheters placed alongside the mother's nipple and a fluid pressure transducer; however, this method needs to use a pump to control fluid flow in the catheters to eliminate the possibility of providing extra fluid to the infants [14], [27], [41].

In this study, we aim to develop a novel system that allows convenient and objective measurement of infants' sucking microstructure in both home and clinical settings. The novel system will function as a diagnostic tool to capture abnormalities of infants' effort during breastfeeding and offer direct assistance to mothers experiencing barriers with breastfeeding. To that end, we have developed a breastfeeding diagnostic device (BDD) that utilizes a conventional feeding tube connected to an air-based pressure transducer to measure infants' sucking microstructure. To avoid wire tangling, the transducer communicates wirelessly to a close-by laptop computer to allow real-time data processing and monitoring the infants' breastfeeding sucking microstructure. The feasibility of the system has been tested on 6 breastfeeding dyads of mother and infant.

## II. METHODS

Human studies reported in this paper are approved by the University of Connecticut Institutional Review Board.

### A. BREASTFEEDING DIAGNOSTIC DEVICE

The Breastfeeding Diagnostic Device (BDD) to allow convenient measurement of sucking microstructure consists of custom-built hardware and software. As displayed in the schematic in Fig. 1, the BDD hardware consists of two units which communicate wirelessly via radio frequency: the pressure recording and transmitting unit, and the data receiving

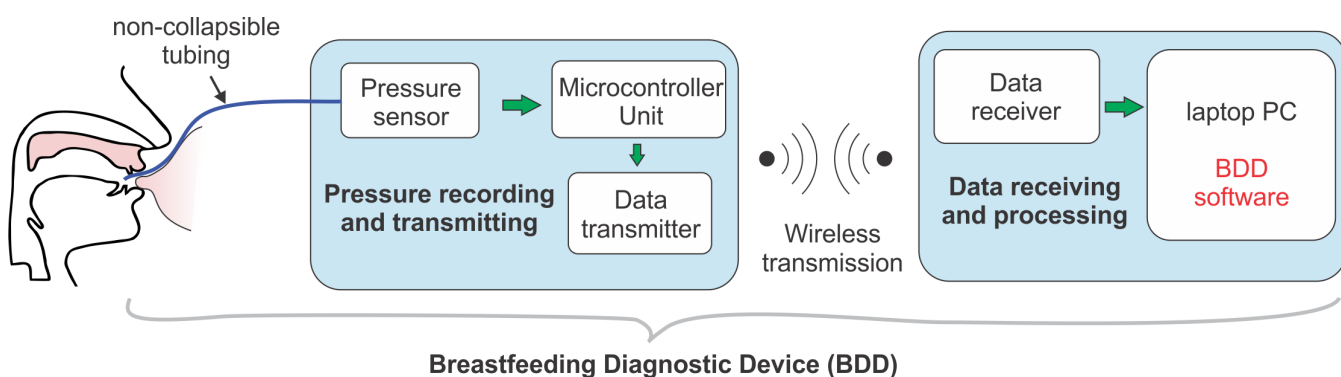

**FIGURE 1.** Schematic diagram of the breastfeeding diagnostic device (BDD) consisting of a pressure recording and transmitting unit and a data receiving and processing unit. Intraoral pressure is probed by an air-filled non-collapsible tubing with one end taped to the maternal or bottle nipple and the other end connected to a silicon-based pressure transducer. The measured pressure value is digitized and transmitted wirelessly to the data receiving and processing unit for data display, processing, storage and interface with users.

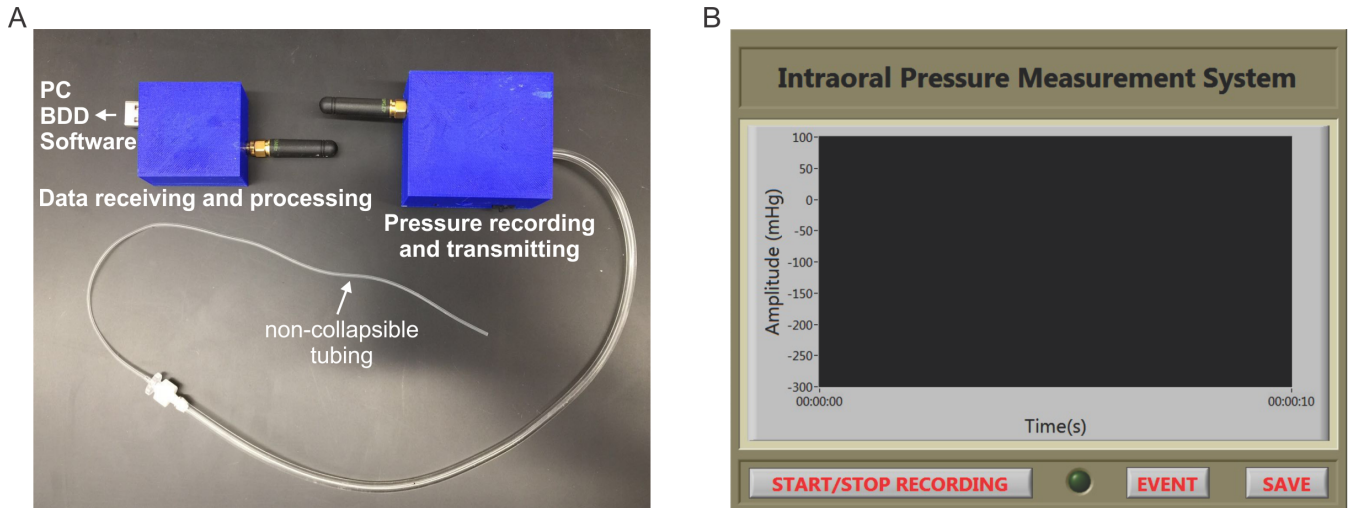

**FIGURE 2.** The prototype picture of the BDD (A) and software interface (B).

and processing unit. Also shown in Fig. 1, the BDD software is developed for the laptop PC to allow live monitoring of the feeding status and storage of intraoral sucking pressure data.

The function of pressure recording and transmitting unit is to sense infants' intraoral pressure, complete analog to digital conversion, and transmit data wirelessly via radio frequency. The unit includes an air-filled non-collapsible tubing, a pressure sensor, a microcontroller unit (MCU), and a data transmitter. To probe the pressure inside infants' mouth, we used a standard non-collapsible feeding tubing (Medela™) that has been widely used to deliver fluid to infants during breast-feeding. The tubing is well-tolerated by infants and can be used in both breast- and bottle-feeding situations. In contrast to the fluid pressure sensing methods used previously, an air pressure sensor (MPX5100) is selected to measure the intraoral pressure to eliminate the need of filling up the tubing with fluid. The open end of the air-filled tubing was taped to the mother's breast at the edge of the areola (for breast-feeding) or on the 60-milliliter feeding bottle (Enfamil™) and the nipple ring (for bottle-feeding), and the other end of the tubing was attached to the pressure sensor. The acquired analog signal of intraoral pressure was digitized by the MCU at 1 KHz, modulated by the data transmitter and transmitted at 475 MHz radio frequency to the nearby data receiving & processing unit, a harmless frequency in compliance with regulations for consumer and clinical devices. The small-framed pressure recording and transmitting unit is battery driven (3.7 V, 500 mAh Lithium ion rechargeable battery) for convenient placement next to the mother-infant dyad and allows continuous recording of up to 8 hours.

The data receiving and processing unit includes a data receiver and a laptop PC. The data receiver demodulates the intraoral pressure from the wireless signals and sends it to the laptop PC via a USB port. The custom-built BDD

software that works on a laptop PC processes the intraoral pressure data and allows convenient interface with the BDD users. As shown in Fig. 2B, the graphical user interface (GUI) of the software adopted a simplified design to avoid unnecessary operational errors, consisting of only a pressure data monitoring chart, three control buttons and a LED indicator. The pressure data monitoring chart displays intraoral pressure in real time to allow the BDD users and researchers to track the breast- or bottle-feeding progress. The start/stop recording button and the LED indicator was designed to control and indicate the data recording process. The event button permits the recording of any occurrence that could affect the recording to inform the post-hoc data processing.

### B. PARTICIPANT RECRUITMENT

Mothers were recruited from the community by flyer, email list announcements, breastfeeding support groups, and an ongoing breastfeeding study. Mothers were screened for eligibility by telephone contact with the study team. Inclusion criteria for mothers are: (1) age range of 18–50 years; (2) at least two weeks post-delivery; (3) an established milk supply; (4) intention to breastfeed at least 3 months; and (5) feeding their infant by breast and/or bottle [8]. Inclusion criteria for infants are those who (1) were admitted to the newborn nursery; (2) born at 38–42 weeks gestational age; and (3) returned to birth weight by 2 weeks after delivery with breastfeeding [2], [27]. Exclusion criteria for mothers include: (1) teenage mother (<18 years of age); (2) presence of inverted nipples; (3) use of a nipple shield; (4) ongoing medical complications; (5) diagnosed with mastitis; (6) tape allergy; and (7) history of smoking which may decrease maternal milk supply [42], [43]. Exclusion criteria for infants are those who were (1) <38 weeks gestational age; (2) diagnosed with ankyloglossia or other congenital anomalies affecting breastfeeding; and (3) supplemented with milk due to poor weight gain after 2 weeks [2], [44], [45].

### C. EXPERIMENTAL PROCEDURE

Since the focus of this study is to develop the BDD and test its feasibility, we conducted both breast- and bottle-feedings on all recruited mother-infant dyads to allow direct comparison. On enrollment, mother-infant dyads were randomized into 2 bottle and 2 breastfeeding sessions. The sessions occurred twice a week at the mid-morning feeding (9:30–11:30 am) with two to three days in between each feeding. Mothers were notified before each home visit which feeding session would be measured. Mothers consented for herself and her infant at the first home visit. Before each feeding, the BDD was calibrated and tested to ensure data was being recorded and transmitted to the computer. The study team connected the feeding and extension tubing to the pressure recording and transmitting unit of the BDD (Fig. 2A). For each breastfeeding session, after the tubing was connected to the BDD, the other end was taped at the base of the maternal breast and at the edge of the maternal areola. The tip of the tubing extended just beyond the maternal nipple. Once the mother was comfortable with the tape and tubing placement, she and the study staff guided the infant to latch on the breast while placing the tubing at the junction of the infants' soft and hard palate. The mother then breastfed her infant.

For each bottle-feeding session, the study team staff filled the 60 mL feeding bottle (Enfamil<sup>TM</sup>) with breast milk or formula. The tubing for BDD (Medela<sup>TM</sup>) was taped at the bottom edge of the nipple ring, similar location as the edge of the maternal areola in breastfeeding situation. The tip of the tubing extended just beyond the nipple. Once the mother was comfortable with the tape and tubing placement on the feeding bottle, she and the study staff guided the infant to seal around the bottle nipple, placing the tubing at the junction of the infants' soft and hard palate. The bottle feeding session ended when infant consumed all milk or after 10 minutes of feeding, whichever occurred first.

The infants' sucking pressure was continuously displayed on the laptop computer, allowing study staff to observe changes in infants' sucking behavior. For both feedings, study staff adjusted the tubing within the infants' mouth to obtain continuous sucking pressure. The recording software displays the sucking pressure in real time and creates a sucking record for off-line data analysis. The study staff documented any interruptions or notable occurrences during the feeding using a data sheet, such as time of first suck or burping, readjustment of the tubing, technical difficulties, and infant sleep/wake state. After the feeding was completed, mothers removed the tubing. The study staff cleaned the tubing with soapy water, rinsed and left to air dry for the next feeding.

### D. DATA ANALYSIS

Customized MATLAB programs (Mathworks R2016b) were used to process the obtained pressure data off-line, which automatically detected sucking events when intraoral pressure was decreased by more than 15 mmHg and registered bursts when there were more than 2 events of sucking

clustered by a 2-sec pause before and after the sucking burst [34]. The sucking microstructure parameters including number of sucks per minute ( $n_s$ ), sucks per burst (spb), number of bursts per minute ( $n_b$ ), intra suck interval (isi), and maximal sucking pressure ( $p_m$ ) were calculated. Data are presented as means  $\pm$  SE.

### III. RESULTS

A total of 7 mother-infant dyads were enrolled in the study. Of the sample, there were 6 infants providing 9 valid recordings for breastfeeding and 10 valid recordings for bottle-feeding. Some recordings provided no data due to movement of tubing after latch or either sleeping or crying during experiment procedure. Of the six infants included in data analysis, four were males with an average age of 25.25 days (range of 19–29 days), and two were females with an average age of 24.5 days (range of 20–29 days). Mothers included in data analysis were on average 31–35 years of age, primigravida ( $n = 2$ ), multigravida ( $n = 4$ ), White ( $n = 4$ ), African American ( $n = 1$ ), Asian ( $n = 1$ ), college educated ( $n = 6$ ), and whose average house hold income was \$81,000.

Intraoral pressure was recorded during both breast- and bottle-feedings in each dyad with typical examples displayed in Figs. 3A and B, respectively. Using the atmospheric pressure as a reference, the measured intraoral pressure during sucking is negative. All six recruited babies have normal breastfeeding behavioral based upon the assessment of a lactation counselor. The recorded intraoral pressure data were displayed at a magnified time scale in Figs. 3C and D.

As shown in Fig. 4, the sucking microstructure parameters were calculated during post-hoc analysis to facilitate comparison of our BDD measurements with previously published results. From recorded intraoral sucking pressure during both breast- (BRF) and bottle-feedings (BTF), we have calculated the number of sucks per minute ( $n_s$ ) as  $56.14 \pm 23.23$  for BRF and  $43.23 \pm 15.49$  for BTF, sucks per burst (spb) as  $7.10 \pm 2.24$  for BRF and  $15.78 \pm 28.60$  for BTF, number of bursts per minute ( $n_b$ ) as  $8.08 \pm 3.04$  for BRF and  $6.18 \pm 2.97$  for BTF, intra suck interval (isi) as  $0.65 \pm 0.17$  s for BRF and  $0.79 \pm 0.12$  s for BTF, and maximal sucking pressure ( $p_m$ ) as  $91.55 \pm 21.83$  mmHg for BRF and  $79.75 \pm 30.66$  mmHg for BTF. There is significant difference in intra suck interval between breast- and bottle-feeding (t-test,  $p = 0.007$  for isi). The other microstructure parameters showed no difference between the groups (t-test,  $p = 0.245$  for  $n_s$ ,  $p = 0.382$  for spb,  $p = 0.152$  for  $n_b$ ,  $p = 0.465$  for  $p_m$ ). The maximum sucking pressure ( $p_m$ ) measured from the BDD is comparable to those reported previous by Taki *et al.* [14] and Geddes *et al.* [27].

### IV. DISCUSSION

Although breastfeeding is pivotal to optimal infant health in the newborn period and throughout the first year of life, there is no objective clinical instrument to evaluate infants' effort during direct breastfeeding, i.e., their sucking microstructure, in the hospital, clinic, and home settings [2]. Mothers' reasons for breastfeeding cessation have been well



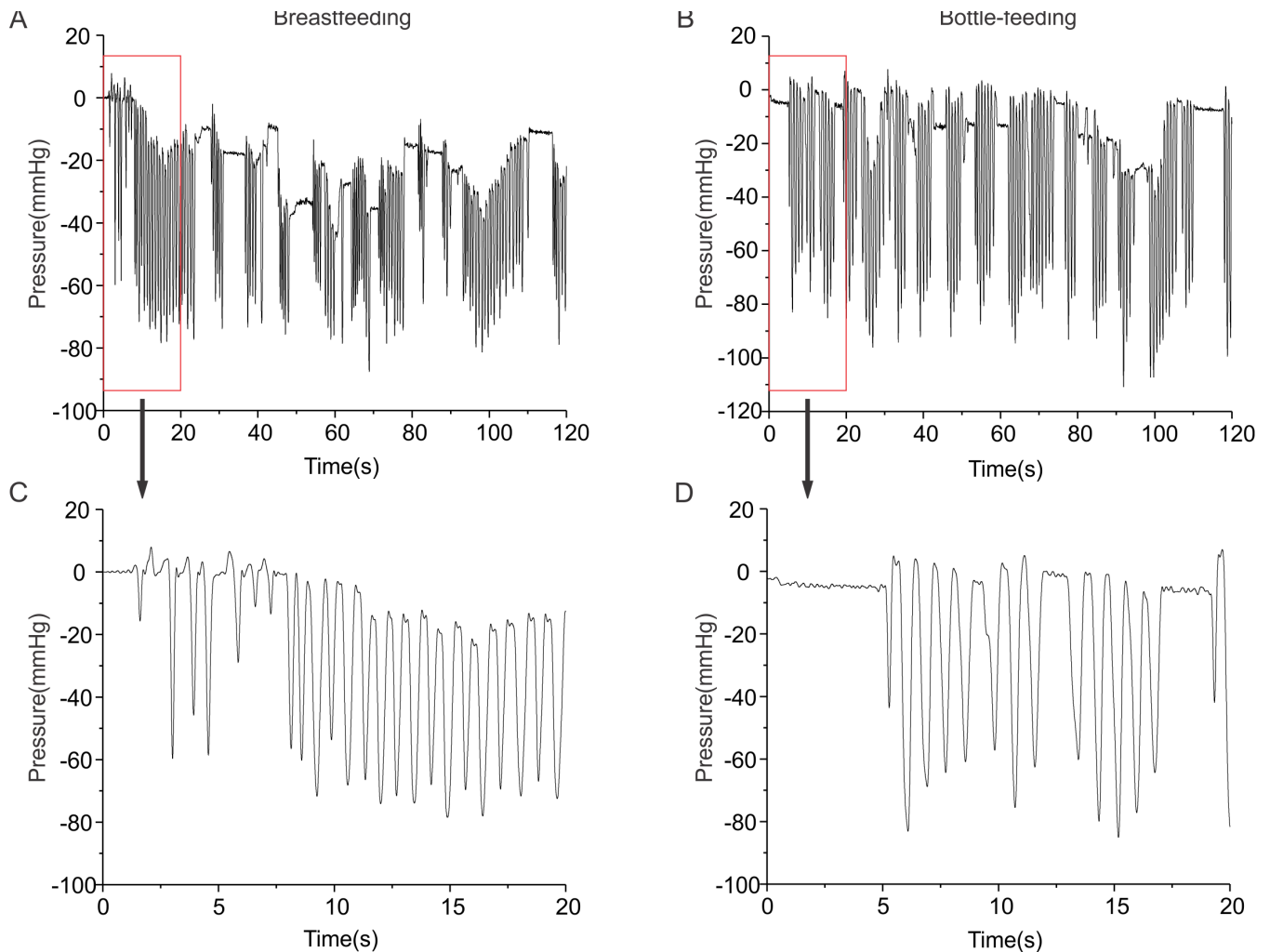

**FIGURE 3.** Representative intraoral pressure recorded by the BDD in both breast- and bottle-feeding situations. Typical 2-minute recordings of intraoral pressure during breast- and bottle-feeding are displayed in (A) and (B), respectively. The magnified views from boxed regions in (A) and (B) are displayed in (C) and (D), respectively.

studied and documented in the literature, including difficulties with infant latch at day 3, ongoing maternal breast and nipple pain at day 7, and perception of maternal milk insufficiency at day 14 [7]. In contrast, infants' efforts which are critical to the success of breastfeeding are difficult to be assessed objectively by current clinical equipment [13], [26]. Thus, the BDD reported in this study possesses profound diagnostic potential of alterations in infants' effort during feeding by offering objective and convenient assessment via the sucking microstructure measure during both breast- and bottle-feedings.

Currently, the gold standard to measure infants' sucking microstructures during breastfeeding is by ultrasound which requires a highly trained professional and a lab setting, limiting its clinical utility for ongoing breastfeeding assessment. Plus, methods like the ultrasounds, video taping, and facial electromyography do not allow direct measurement of intraoral pressure and thus will not capture the full parameter set of the sucking microstructure. On the other hand,

all the sucking microstructure parameters can be derived from intraoral pressure recordings. The sucking microstructure is however more widely measured during bottle-feeding using a sucking apparatus like the Neonur, which includes a custom-built cap with a pressure transducer that has become the gold standard to measure milk pressure during bottle-feeding [32]–[34]. Several investigators have used a fluid filled feeding tube placed at the maternal nipple to capture infants' sucking microstructure during breastfeeding in a laboratory setting. These investigators managed to collect infants' normative microstructure of sucking at birth and 1 month, but it required a 3-way stopcock to connect the fluid-filled tube, the pressure sensor and a pump used to control fluid flow, which has prevented its wider application in home settings due to the increased complexity and inconvenience [14], [27], [41].

Regarding the measurement of infants' sucking microstructure, the BDD in this report excels in the following four aspects as compared with previous means. First, the BDD

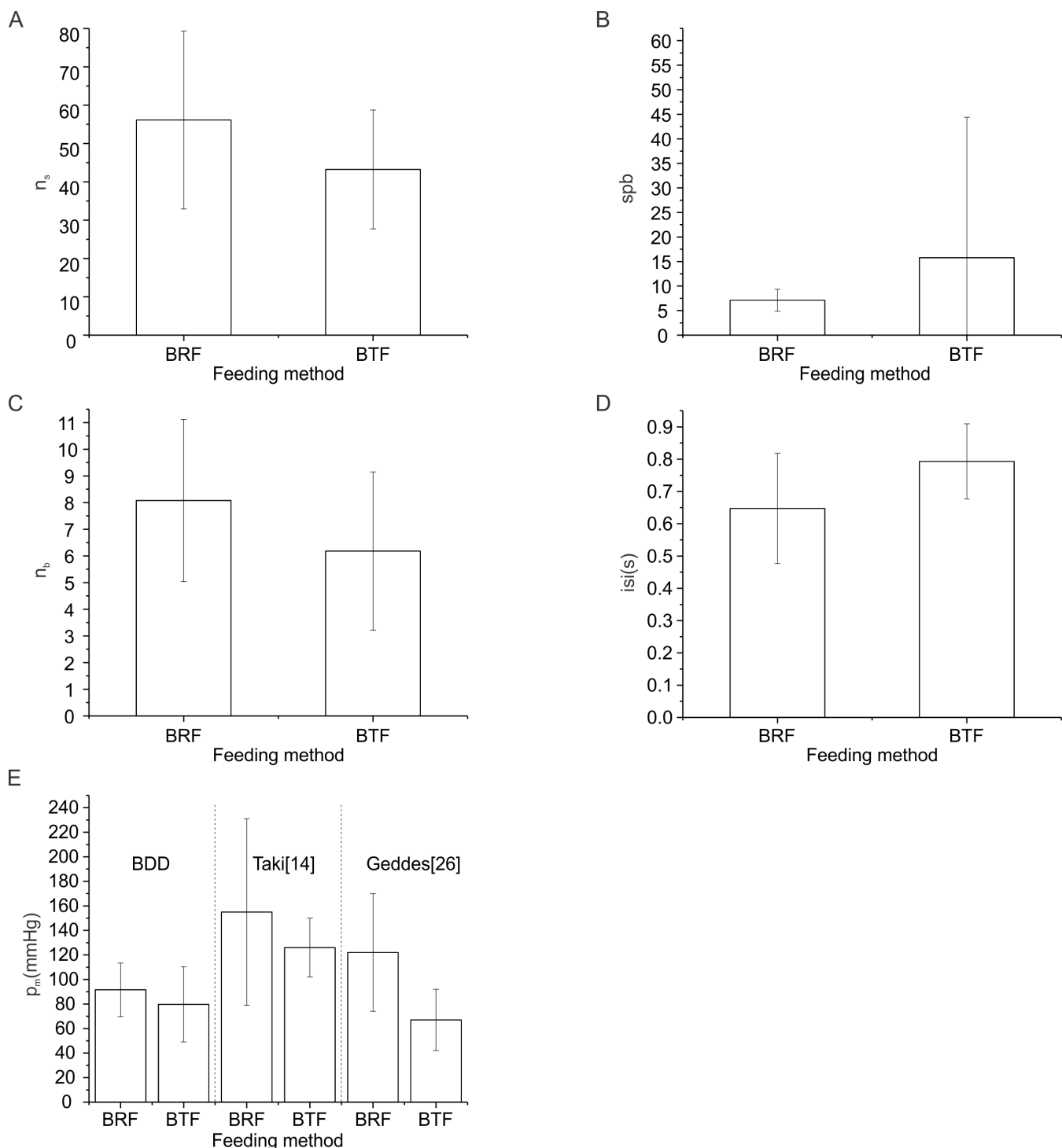

**FIGURE 4.** Sucking microstructure parameters in both breast- and bottle-feeding situations. (A) number of sucks per minute ( $n_s$ ), (B) sucks per burst (spb), (C) number of bursts per minute ( $n_b$ ), (D) intra suck interval (isi), (E) maximal sucking pressure ( $p_m$ ) acquired by BDD compared to other published results.

uses an air-based pressure measuring device to allow precise and direct measurement of the intraoral pressure without introducing additional fluid to infants; newborn infants are recommended to be fed exclusively with milk and not confounded by the taste of other fluids. Second, the small

size of the pressure recording and transmitting unit allows convenient use of the BDD by the feeding mothers or caregivers to transmit the pressure data wirelessly to a nearby laptop PC, eliminating any wire tangling for versatile use in both clinical and home settings. Third, the BDD effectively

reduces the cost by utilizing a standard laptop PC for data monitoring and interface with users. Fourth, the choice of a standard non-collapse feeding tubing (Medela™) to capture the infants' changing intraoral pressure allows the BDD to measure sucking microstructure in both breast- and bottle-feeding situations. The Medela™ feeding tubing is well accepted and tolerated by infants in both feeding situations.

The sucking microstructure parameters measured using the BDD are comparable to other methods reported in the literature, further confirming the feasibility of using an air-based pressure measuring approach to measure infant intraoral pressure during feeding. The choice of Mega Hz radio frequency rather than Giga Hz or blue-tooth frequencies emphasizes reliable wireless communications rather than a wide communication bandwidth to ensure robust recordings of intraoral pressure. With additional studies on more mother-infant dyads, we anticipate detection of more distinct features between breast- and bottle-feedings using the BDD.

In this pilot study, we demonstrate the feasibility of acquiring sucking pressure with BDD during both breast-feeding and bottle-feeding and qualitatively assess the infant's sucking efforts based upon the five parameters of the sucking microstructures with a small sample size of participants who are not encountering difficulties with breast-feeding. By recruiting additional mother and infant dyads especially those with alterations in infants' effort during breastfeeding, we anticipate to further revise and include more parameters through rigorous statistical analysis to better reveal the infants' sucking efforts during feeding. Then, the BDD will provide clinically meaningful guidance to mothers in real time to assess their infants' feeding: to observe in real time their infant's effort, compare it to a normative range, be assured their infant's effort is typical, and be reminded to seek professional lactation support. The BDD will be also be influential in sustaining infants' correct position at mothers' breast for persistent and efficient breast feeding.

## V. CONCLUSION

We developed a breastfeeding diagnostic device to allow for a convenient and objective measurement of infants' sucking microstructure in both home and clinical settings. Our study has demonstrated the feasibility of using an air-based pressure transducer to probe the intraoral pressure in both breast- and bottle-feeding situations. This BDD can be used by health care providers working with preterm and full term infants to acquire valuable information about infants' motor and neurodevelopment. The BDD will also provide an objective metric useful in research areas relevant to infant behaviors, an early assessment of neurodevelopment, and potentially become a screening tool for developmental disabilities, such as autism spectrum disorder. There are approximately 4 million infants in the USA, and by 3 months 66% are not exclusively breastfed. Thus, the BDD has great potential to meet this unmet clinical and market need no other device provides.

## ACKNOWLEDGMENT

The author R. F. Lucas thanks E. Keller for her assistance in the human studies.

## REFERENCES

- [1] *Breastfeeding Report Card—United States, 2016*, Centers Disease Control Prevention, Atlanta, GA, USA, 2016.
- [2] A. I. Eidelman *et al.*, "Breastfeeding and the use of human milk," *Pediatrics*, vol. 129, no. 3, pp. e827–e841, 2012.
- [3] C. Binns, M. Lee, and W. Y. Low, "The long-term public health benefits of breastfeeding," *Asia Pacific J. Public Health*, vol. 28, pp. 7–14, Jan. 2016.
- [4] National Immunization Survey, *Breastfeeding Among U.S. Children Born 2002–2014, CDC National Immunization Survey*, Center Disease Control, Atlanta, GA, USA, 2017.
- [5] G. A. Martinez and J. P. Nalezienski, "The recent trend in breast-feeding," *Pediatrics*, vol. 64, no. 5, pp. 686–692, 1979.
- [6] E. M. Taveras, A. M. Capra, P. A. Bravement, N. G. Jensvold, G. J. Escobar, and T. A. Lieu, "Clinician support and psychosocial risk factors associated with breastfeeding discontinuation," *Pediatrics*, vol. 112, no. 1, pp. 108–115, 2003.
- [7] E. A. Wagner, C. J. Chantry, K. G. Dewey, and L. A. Nommsen-Rivers, "Breastfeeding concerns at 3 and 7 days postpartum and feeding status at 2 months," *Pediatrics*, vol. 132, pp. e866–e875, Sep. 2013.
- [8] E. C. Odom, R. Li, K. S. Scanlon, C. G. Perrine, and L. Grummer-Strawn, "Reasons for earlier than desired cessation of breastfeeding," *Pediatrics*, vol. 131, p. e726–e732, Mar. 2013.
- [9] A. M. Stuebe, B. J. Horton, E. Chetwynd, S. Watkins, K. Grewen, and S. Meltzer-Brody, "Prevalence and risk factors for early, undesired weaning attributed to lactation dysfunction," *J. Women's Health*, vol. 23, no. 5, pp. 404–412, 2014.
- [10] N. M. Hurst, "Recognizing and treating delayed or failed lactogenesis II," *J. Midwifery Women's Health*, vol. 52, no. 6, pp. 588–594, 2007.
- [11] J. Lauwers and A. Swisher, *Counseling the Nursing Mother: A Lactation Consultant's Guide*, 9th ed. Sudbury, MA, USA: Jones & Bartlett Learning, 2011.
- [12] K. Cadwell, "Latching-on and suckling of the healthy term neonate: Breastfeeding assessment," *J. Midwifery Women's Health*, vol. 52, no. 6, pp. 638–642, 2007.
- [13] P. D. Hill and T. S. Johnson, "Assessment of breastfeeding and infant growth," *J. Midwifery Women's Health*, vol. 52, no. 6, pp. 571–578, 2007.
- [14] M. Taki, K. Mizuno, M. Murase, Y. Nishida, K. Itabashi, and Y. Mukai, "Maturation changes in the feeding behaviour of infants—A comparison between breast-feeding and bottle-feeding," *Acta Paediatrica*, vol. 99, pp. 61–67, Jan. 2010.
- [15] V. S. Sakalidis and D. T. Geddes, "Suck-swallow-breathe dynamics in breastfed infants," *J. Hum. Lactation*, vol. 32, pp. 201–211, May 2016.
- [16] S. P. da Costa, C. P. van der Schans, S. R. Boelema, E. van der Meij, M. A. Boerman, and A. F. Bos, "Sucking patterns in fullterm infants between birth and 10 weeks of age," *Infant Behav. Develop.*, vol. 33, no. 1, pp. 61–67, 2010.
- [17] M. Cunha, J. Barreiros, I. Gonçalves, and H. Figueiredo, "Nutritive sucking pattern—From very low birth weight preterm to term newborn," *Early Hum. Develop.*, vol. 85, pp. 125–130, Feb. 2009.
- [18] S. P. da Costa, L. van den Engel-Hoek, and A. F. Bos, "Sucking and swallowing in infants and diagnostic tools," *J. Perinatol.*, vol. 28, pp. 247–257 Apr. 2008.
- [19] R. White-Traut, K. Rankin, R. Lucas, N. Shapiro, L. Liu, and B. Medoff-Cooper, "Evaluating sucking maturation using two pressure thresholds," *Early Hum. Develop.*, vol. 89, pp. 833–837, Oct. 2013.
- [20] R. Rogers and J. Arvedson, "Assessment of infant oral sensorimotor and swallowing function," *Develop. Disab. Res. Rev.*, vol. 11, pp. 74–82, Feb. 2005.
- [21] M. Aizawa, K. Mizuno, and M. Tamura, "Neonatal sucking behavior: Comparison of perioral movement during breast-feeding and bottle feeding," *Pediatrics Int.*, vol. 52, pp. 104–108, Feb. 2010.
- [22] X. L. Liao, C. Zhang, C. Wei-Bang, and P. C. Chandler-Laney, "Collective intelligence of temporal statistics for segmenting sustained infant feeding behaviors in videos," in *Proc. IEEE Int. Conf. Multimedia Expo Workshops (ICMEW)*, Jul. 2016, pp. 1–6.
- [23] S. P. da Costa, N. Hübl, N. Kaufman, and A. F. Bos, "New scoring system improves inter-rater reliability of the Neonatal Oral-Motor Assessment Scale," *Acta Paediatrica*, vol. 105, no. 8, pp. e339–e344, 2016.

- [24] D. Elad *et al.*, "Biomechanics of milk extraction during breast-feeding," *Proc. Nat. Acad. Sci. USA*, vol. 111, pp. 5230–5235, Apr. 2014.
- [25] V. S. Sakalidis *et al.*, "Oxygen saturation and suck-swallow-breathe coordination of term infants during breastfeeding and feeding from a teat releasing milk only with vacuum," *Int. J. Pediatrics*, vol. 2012, Apr. 2012, Art. no. 130769.
- [26] D. T. Geddes, L. M. Chadwick, J. C. Kent, C. P. Garbin, and P. E. Hartmann, "Ultrasound imaging of infant swallowing during breast-feeding," *Dysphagia*, vol. 25, no. 3, pp. 183–191, Sep. 2010.
- [27] D. T. Geddes *et al.*, "Tongue movement and intra-oral vacuum of term infants during breastfeeding and feeding from an experimental teat that released milk under vacuum only," *Early Hum. Develop.*, vol. 88, pp. 443–449 Jun. 2012.
- [28] G. Monaci and M. Woolridge, "Ultrasound video analysis for understanding infant breastfeeding," in *Proc. 18th IEEE Int. Conf. Image Process.*, Sep. 2011, pp. 1765–1768.
- [29] E. C. L. Franca, C. B. Sousa, L. C. Aragão, and L. R. Costa, "Electromyographic analysis of masseter muscle in newborns during suction in breast, bottle or cup feeding," *BMC Pregnancy Childbirth*, vol. 14, p. 154, May 2014.
- [30] C. F. Gomes, Z. Thomson, and J. R. Cardoso, "Utilization of surface electromyography during the feeding of term and preterm infants: A literature review," *Develop. Med. Child Neurol.*, vol. 51, pp. 936–942, Dec. 2009.
- [31] Y. L. Wang *et al.*, "Development of a wireless oral-feeding monitoring system for preterm infants," *IEEE J. Biomed. Health Informat.*, vol. 19, no. 3, pp. 866–873, May 2015.
- [32] B. Medoff-Cooper, J. M. McGrath, and J. Shults, "Feeding patterns of full-term and preterm infants at forty weeks postconceptional age," *J. Develop. Behav. Pediatrisc*, vol. 23, pp. 231–236, Aug. 2002.
- [33] B. Medoff-Cooper, W. Bilker, and J. M. Kaplan, "Sucking patterns and behavioral state in 1- and 2-day-old full-term infants," *J. Obstetric Gynecol. Neonatal Nursing*, vol. 39, pp. 519–524, Sep./Oct. 2010.
- [34] B. Medoff-Cooper, W. B. Bilker, and J. M. Kaplan, "Suckling behavior as a function of gestational age: A cross-sectional study," *Infant Behav. Develop.*, vol. 24, no. 1, pp. 83–94, 2001.
- [35] E. Tamilia, F. Taffoni, D. Formica, L. Ricci, E. Schena, and F. Keller, "Technological solutions and main indices for the assessment of newborns' nutritive sucking: A review," *Sensors*, vol. 14, no. 1, pp. 634–658, Jan. 2014.
- [36] B. Medoff-Cooper, J. Shults, and J. Kaplan, "Sucking behavior of preterm neonates as a predictor of developmental outcomes," *J. Develop. Behav. Pediatrics*, vol. 30, pp. 16–22, Feb. 2009.
- [37] E. Nishi, Y. Nagamatsu, and T. Niikawa, "Measurement of force applied by infant tongue to the nipple during sucking and investigation of the mechanism of tongue movement," in *Proc. 38th Annu. Int. Conf. IEEE Eng. Med. Biol. Soc. (EMBC)*, Aug. 2016, pp. 2042–2045.
- [38] E. Tamilia, D. Formica, A. Scaini, and F. Taffoni, "An automated system for the analysis of newborns' oral-motor behavior," *IEEE Trans. Neural Syst. Rehabil. Eng.*, vol. 24, no. 12, pp. 1294–1303, Dec. 2016.
- [39] F. Taffoni *et al.*, "A novel system to study the coordination of sucking and breathing in newborns during bottle feeding," *IEEE Sensors J.*, vol. 16, no. 23, pp. 8589–8596, Dec. 2016.
- [40] C.-T. Chen, Y.-L. Wang, C.-A. Wang, M.-J. Ko, W.-C. Fang, and B.-S. Lin, "Wireless monitoring system for oral-feeding evaluation of preterm infants," *IEEE Trans. Biomed. Circuits Syst.*, vol. 9, no. 5, pp. 678–685, Oct. 2015.
- [41] F. Zhang, H. Xia, X. Li, L. Qin, H. Gu, and X. Xu, "Intraoral vacuum of breast-feeding newborns within the first 24 hr: Cesarean section versus vaginal delivery," *Biol. Res. Nursing*, vol. 18, no. 4, pp. 445–453, Jul. 2016.
- [42] B. A. Bailey and H. N. Wright, "Breastfeeding initiation in a rural sample: Predictive factors and the role of smoking," *J. Hum. Lactation*, vol. 27, pp. 33–40, Feb. 2011.
- [43] L. H. Amir and S. M. Donath, "Does maternal smoking have a negative physiological effect on breastfeeding? The epidemiological evidence," *Birth*, vol. 29, pp. 112–123, Jun. 2002.
- [44] D. O. Francis, S. Krishnaswami, and M. McPheeters, "Treatment of ankyloglossia and breastfeeding outcomes: A systematic review," *Pediatrics*, vol. 135, p. e1458, Apr. 2015.
- [45] M. Walker, "Breastfeeding the late preterm infant," *J. Obstetric, Gynecol., Neonatal Nursing*, vol. 37, no. 6, pp. 692–701, 2008.