

Received 31 October 2012, revised 16 January 2013, accepted 15 March 2013. Date of current version 4 June 2013.

Digital Object Identifier 10.1109/JTEHM.2013.2253598

Development of Novel Non-contact Electrodes for Mobile Electrocardiogram Monitoring System

**BOR-SHYH LIN (Member, IEEE)^{1,2}, WILLY CHOU², HSING-YU WANG¹, YAN-JUN HUANG¹,
AND JENG-SHYANG PAN (Senior Member, IEEE)³**

¹Institute of Imaging and Biomedical Photonics, and Biomedical Electronics Translational Research Center, National Chiao Tung University, Tainan 711, Taiwan

²Department of Medical Research, Chi-Mei Medical Center, Tainan 710, Taiwan

³Department of Electronic Engineering, National Kaohsiung University of Applied Sciences, Kaohsiung 10488, Taiwan and Innovative Information Industry Research Center (IIIRC), Shenzhen Graduate School, Harbin Institute of Technology, Shenzhen 518000, China

CORRESPONDING AUTHOR: B-S. LIN (borshyhlin@mail.nctu.edu.tw)

ABSTRACT Real-time monitoring of cardiac health is helpful for patients with cardiovascular disease. Many telemedicine systems based on ubiquitous computing and communication techniques have been proposed for monitoring the user's electrocardiogram (ECG) anywhere and anytime. Usually, wet electrodes are used in these telemedicine systems. However, wet electrodes require conduction gels and skin preparation that can be inconvenient and uncomfortable for users. In order to overcome this issue, a new non-contact electrode circuit was proposed and applied in developing a mobile electrocardiogram monitoring system. The proposed non-contact electrode can measure bio-potentials across thin clothing, allowing it to be embedded in a user's normal clothing to monitor ECG in daily life. We attempted to simplify the design of these non-contact electrodes to reduce power consumption while continuing to provide good signal quality. The electrical specifications and the performance of monitoring arrhythmia in clinical settings were also validated to investigate the reliability of the proposed design. Experimental results show that the proposed non-contact electrode provides good signal quality for measuring ECG across thin clothes.

INDEX TERMS Arrhythmia, electrocardiogram (ECG), mobile electrocardiogram monitoring system, non-contact electrode, telemedicine.

I. INTRODUCTION

Cardiovascular disease (CVD) is one of the main causes of death across most countries. Providing prompt emergency care within the "golden hour" (one hour of onset of cardiac symptoms) can greatly reduce mortality. Therefore, real-time monitoring of cardiac health in daily life is useful for patients with cardiovascular disease.

Currently, outpatient service is still the major healthcare approach for the common cardiovascular diseases. However, recently telemedicine systems that integrate with wireless communication techniques, such as wireless local area network (WLAN), global system by using mobile communications (GSM) network, and general packet radio service (GPRS) mobile network, have been introduced that allow mobile patients to receive healthcare anywhere and any-

time, within limitations [1]–[5]. However, conventional wet electrodes, which require conduction gels and even skin preparation to reduce the skin–electrode interface impedance, are most frequently used for the above telemedicine systems. And these procedures tend to be uncomfortable and inconvenient for users. The development of wearable sensing devices would allow telemedicine systems to monitor real-time physiological signals comfortably.

Various kinds of dry electrodes, such as metal electrodes and textile electrodes, which can measure bio-potentials without conductive gels, have been proposed for developing wearable sensing devices in several previous studies [6]–[9]. Anliker et al. proposed gold electrodes to design an AMON system for monitoring ECG, blood pressure, and SpO₂ [6]. Catrysse et al. proposed textile sensors to develop a wireless

monitoring suit [7]. In 2010, Beckmann et al. investigated the characteristics of textile electrodes for measuring ECG, and made a specification comparison between different textile electrodes [8]. Lin et al. developed dry foam electrodes to monitor long-term EEG [9]. Although these novel dry electrodes can measure bio-potentials without conductive gels, contact with the user's skin, and thus risk of irritation, is still necessary.

Different from the conventional wet electrodes and novel dry electrodes, which tend to minimize the skin-electrode interface impedance, non-contact electrodes, developed by the concept of coupling capacitance, were also proposed for wearable sensing devices recently [10]–[14]. In 2008, Oehler et al. developed capacitive electrodes on a multi-channel portable ECG system [10]. Matsuda et al. proposed a capacitively coupled electrode for ECG monitoring in car driving [11]. In 2012, Baek et al. also used active electrodes to develop a health monitoring chair for long-term ECG monitoring [12]. In 2010, Eilebrecht et al. designed a 3×3 electrode matrix for monitoring ECG [13]. In 2012, Chi et al. combined the input capacitance cancellation circuit and the bootstrap circuit with the active electrode to develop non-contact electrodes for ECG and EEG monitoring [14], [15]. Due to the advantages of measuring bio-potentials across clothing, it may be practicable to embed non-contact electrodes in a user's normal clothing to monitor the user's ECG in daily life.

In this study, a novel non-contact electrode was also proposed and applied in developing a mobile electrocardiogram monitoring system. Based on the common concept of non-contact electrode, we attempt to propose a new non-contact electrode circuit. Under the condition of providing good signal quality, the design of the proposed non-contact electrode was simplified to reduce power consumption effectively. Here, a wireless ECG acquisition module and an Android mobile system platform were also designed to monitor real-time ECG wirelessly. Finally the electrical specifications of the proposed non-contact electrode were validated in this study. And the motion artifact issue and the performance of monitoring arrhythmia in clinical settings were also tested to investigate the reliability of the proposed design. The rest of the paper is organized as follows. Section II and Section III introduce the design concept of the novel non-contact electrode, and the architecture of the mobile electrocardiogram monitoring system respectively. The performance and discussions of the novel non-contact electrode are investigated in Section IV and Section V. In Section VI, the conclusion is drawn.

II. DESIGN OF NON-CONTACT ELECTRODES

The basic concept of the proposed novel non-contact electrode is to construct a conducting plate covered by an insulating layer to form a parallel plate capacitor with the skin. Therefore, the non-contact electrode can couple bio-potential signals capacitively to a bio-amplifier. However,

the impedance of skin-electrode interface is very high due to the small capacitance between the skin and the conducting plate, and it will cause the non-contact electrode to become very sensitive to interferences. In order to reduce the influence of the varying and high impedance of the skin-electrode interface, an impedance converter is used to connect to the conducting plate. The basic scheme of the proposed non-contact electrode is shown in Fig. 1(a). Here, C denotes the capacitor resulting from the skin-electrode interface. An impedance Z is connected with a reference voltage V_{ref} to provide a bias voltage to ensure the input bio-potentials are in the action layer region of the impedance converter.

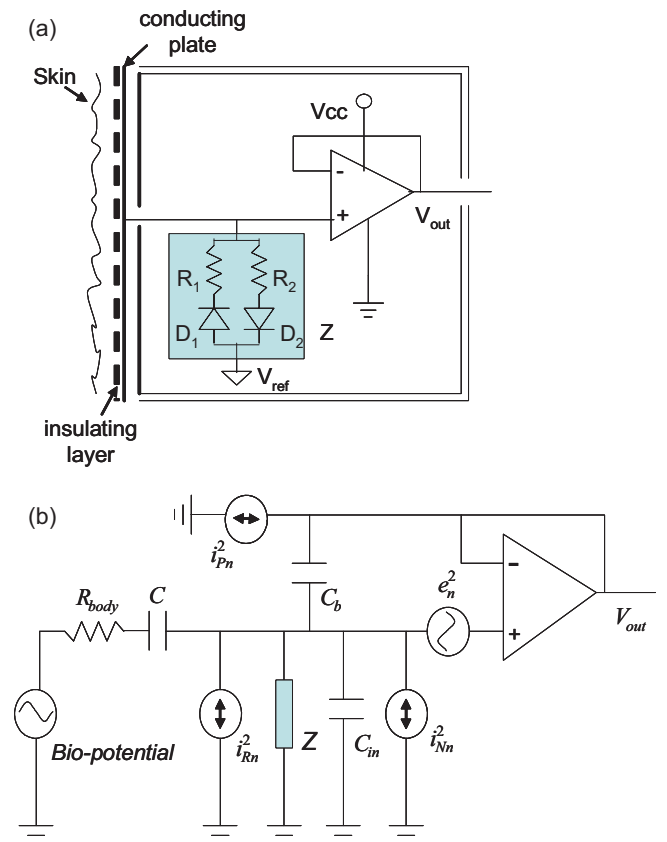

FIGURE 1. (a) Basic scheme of the proposed noncontact electrode and (b) its equal model for noise analysis.

The equivalent model of the proposed non-contact electrode for noise analysis is then shown in Fig. 1(b). Here, C_{in} means the total parasitic capacitance of the operational amplifier, which is used as the impedance converter. The capacitance effect C_b results from the potential difference between the positive terminal and negative terminal on the operational amplifier. The major noise sources include the input voltage noise e_n^2 , the positive input current noise i_{Pn}^2 , the negative input current noise i_{Nn}^2 of the operational amplifier, and the current noise i_{Rn}^2 of the impedance Z . Obviously, the input-referred noise is mainly affected by the parameters of C , C_b , C_{in} and Z . However, the value C_b is the electrical characteristic of the operational amplifier, and is difficult to adjust. For

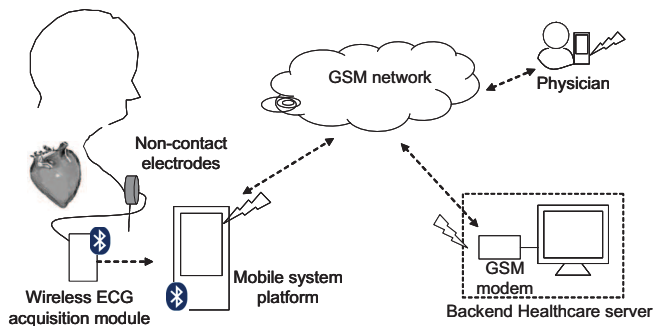

FIGURE 2. Basic scheme of proposed mobile ECG monitoring system.

the equivalent capacitance C of the skin-electrode interface, it inevitably decreases, causing larger input-referred noise, when the distance between the skin and the conducting plate increases. Therefore, in order to reduce the input-referred noise, the adjustment of the parasitic capacitance C_{in} and the impedance Z may be relatively practicable. In this study, the guarding technique is used to improve the influence of the parasitic capacitance C_{in} . Moreover, the parallel connection of two reverse diodes, which are connected with two series resistances, is used to replace the impedance Z to provide high impedance. Here, the diodes with low leakage current are selected, and the series resistances can decrease the forward bias of the diodes effectively.

III. SYSTEM ARCHITECTURE AND DESIGN

Fig. 2 illustrates the system architecture of the proposed mobile electrocardiogram monitoring system. The system hardware consists of non-contact electrodes, a wireless ECG acquisition module, and a mobile system platform. Here, the proposed non-contact electrode was designed to measure ECG without contacting the user’s skin directly. Therefore, the user can wear the non-contact electrode to monitor real-time ECG across thin clothes. The proposed wireless ECG acquisition module was designed to acquire ECG from the non-contact electrodes, and transmit it to the mobile system platform wirelessly via Bluetooth. Then, an ECG monitoring program built into the mobile system platform will continuously monitor the user’s heart rate. When the abnormal heart rate is detected, the ECG monitoring program can send an SMS message with raw ECG data to the backend healthcare server to request emergency treatment. Based on the SMS mechanism, the cardiac state of the patient can be monitored anywhere in the globe if they are under the coverage of a GSM cellular network.

A. IMPLEMENTATION OF NON-CONTACT ELECTRODE

The implementation of the proposed non-contact electrode is shown in Fig. 3(a). Here, a printed circuit board (PCB) copper plate with an area of $2 \times 2 \text{ cm}^2$ is used as the conducting plate. The circuit of non-contact electrode is placed in the opposite side of the conducting plate. And the gap between the PCB and the shielding layer is filled with hot melt adhesive (HMA) to hold the conducting plate. Here, the shielding layer is

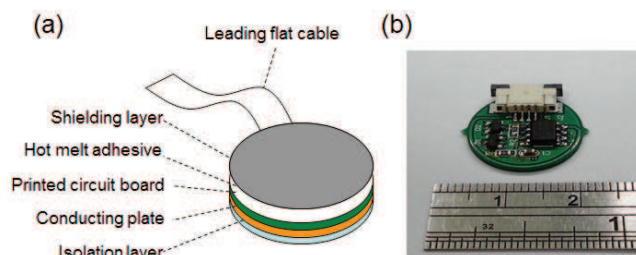

FIGURE 3. (a) Implementation illustration and (b) photograph of proposed noncontact electrode circuit.

formed by covering with aluminum foil, and plastic tape is also used to cover the non-contact electrode to form the isolation layer. Finally, the electrode is topped with Velcro so it can be attached to clothing easily and conveniently. Fig. 3(b) shows a photograph of the proposed non-contact electrode circuit.

B. WIRELESS ECG ACQUISITION MODULE

Fig. 4(a) shows the block diagram of the proposed wireless ECG acquisition module. Here, the front-end amplifier circuit, which contains a pre-amplifier and a band-pass filter, was designed to amplify and filter ECG signals obtained from the non-contact electrodes. The gain of the front-end amplifier circuit is set to 500 over the frequency band of 0.01–120 Hz. Then, the amplified ECG signal is digitized by a 12-bit analog-to-digital converter (ADC), built into the microprocessor, with a sampling rate of 512 Hz. The microprocessor (TI MSP430) was used to control the ADC and peripheral circuits, and send ECG data to Bluetooth module. The size of the wireless ECG acquisition module is about $7.5 \times 3.5 \text{ cm}^2$. It operates at 25 mA with a

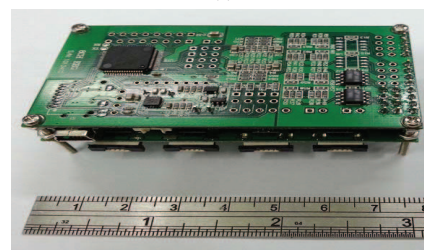
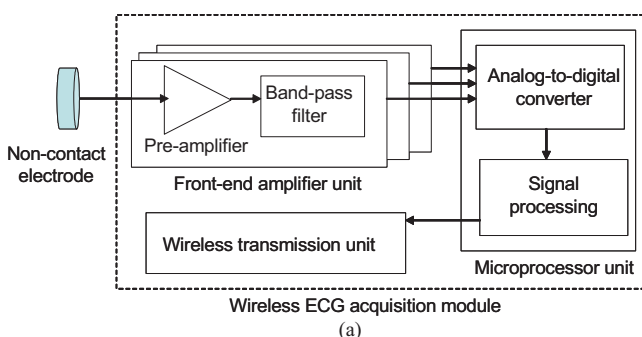

FIGURE 4. (a) Block diagram and (b) photograph of proposed wireless ECG acquisition module.

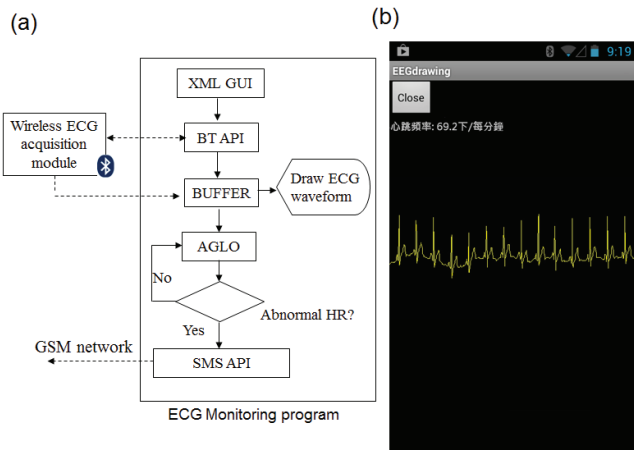

FIGURE 5. (a) Operation procedure and (b) screenshot of ECG monitoring program.

3.7-V DC power supply, and can continuously operate over 35 hours with a commercial 1100 mAh Li-ion battery. Its advantages of small volume and low power consumption are suitable for monitoring real-time ECG in daily life. Fig. 4(b) shows a photograph of the proposed wireless ECG acquisition module.

C. MOBILE SYSTEM PLATFORM

A commercial mobile phone with the Android operation system was used as the mobile system platform in this study. An ECG monitoring program, developed using the Eclipse IDE with Android SDK and Java Development Kit, was built into the mobile system platform to monitor the user's heart rate. Fig. 5(a) specifies the operation procedure of the ECG monitoring program. In the beginning, the ECG monitoring program calls the BT API thread to locate the Bluetooth device. When the wireless ECG acquisition module is found, the BT API thread will try to create an SPP stream to connect the mobile phone with the wireless ECG acquisition module. Then, received ECG data will be sent to BUFFER, and displayed on the screen. Here, BUFFER is a container with link-list structure and is used to store raw ECG data. Next, the AGLO thread, designed by using the heart rate detection algorithm in [12], calculates heart rate from ten-second ECG data every five seconds. If an abnormal state of heart rate is detected, the ECG monitoring program will call the SMS API thread to send an SMS message to the backend healthcare server. Fig. 5(b) shows the screenshot of the ECG monitoring program.

IV. RESULTS

A. ELECTRICAL SPECIFICATIONS OF NON-CONTACT ELECTRODE

The electrical characteristics of the proposed non-contact electrode are investigated in this section. The experiment illustration for the electrical characteristic test is shown in Fig. 6(a). In this experiment, a function generator was used to produce a sine-wave signal with 1 V p-p as the input signal of the non-contact electrode. The frequency of the sine-wave

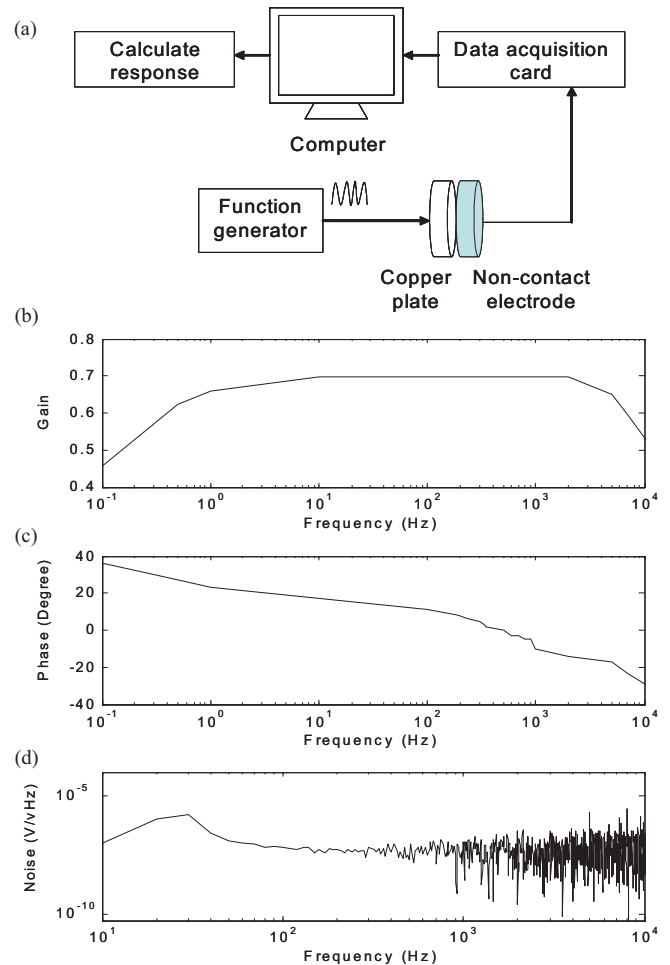

FIGURE 6. (a) and (b) Experiment illustration for electrical characteristic test and magnitude response. (c) Phase response. (d) Referred noise spectrum of proposed noncontact electrode.

was varied from 0.1 Hz to 50 kHz. The output of the function generator connected to a copper plate, which connected the conducting plate of the non-contact electrode across the tape. Next, the data acquisition card was used to acquire the output signal of the proposed non-contact electrode, and transmit it to a computer to calculate the electrical characteristics. The magnitude response, phase response and output-referred noise spectrum of the proposed non-contact electrode are shown in Fig. 6(b), Fig. 6(c) and Fig. 6(d). The magnitude response of the proposed non-contact electrode presents a high-pass filter. And the magnitude response attenuates in the high frequency due to the slew rate of the used operational amplifier. It shows that the magnitude response in the frequency band between 0.5 Hz and 10000 Hz is stable, and is suitable for most bio-potentials.

The magnitude response in Fig. 6(b) contains two poles at about 1 Hz and 3000 Hz respectively. Therefore, the phase response of the proposed non-contact electrodes decreases rapidly at about 1 Hz and 3000 Hz. As mentioned above, the output-referred noise voltage depends on the performance of the used operational amplifier for noise. Therefore, the tendency of the proposed non-contact electrode for noise

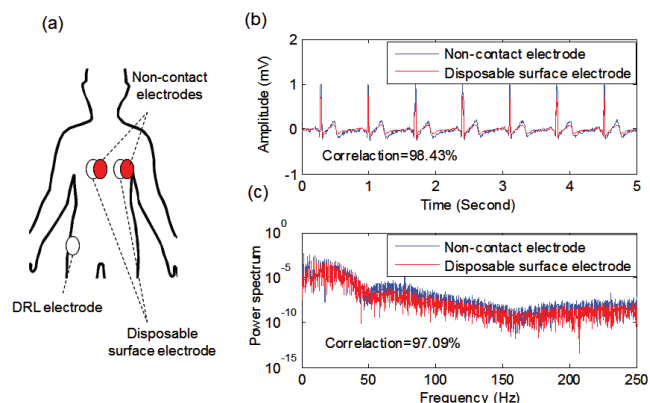

FIGURE 7. (a) Experiment illustration for signal quality test. (b) and (c) Comparison between ECG signal qualities by using different electrodes in time domain and frequency domain.

spectrum is similar to that of the used operational amplifier. Here, low-frequency noise, mainly flicker noise, is larger than high-frequency noise. Because of the decrease of flicker noise with the increase of the frequency, shot noise or white noise contributes the major part of noise in higher frequency. Moreover, noises caused by other components or power line interference also affect the proposed non-contact electrode. Environmental noise, such as power line interference, can be effectively reduced using shielding techniques.

B. ECG SIGNAL QUALITY OF NON-CONTACT ELECTRODE

In this section, the signal quality of bio-potentials measured by using the proposed non-contact electrode is investigated. Here, bio-potentials measured by using the proposed non-contact electrode across thin clothes are compared with that of disposable surface electrodes. First, ECG signals measured by using different electrodes are compared. Fig. 7(a) illustrates the experiment design for testing ECG signal quality. The non-contact electrodes were placed across the heart to measure lead I ECG signal, and the disposable surface electrodes were placed close to these non-contact electrodes to measure ECG simultaneously. The ECG signal qualities using different electrodes in the time domain and frequency domain are shown in Fig. 7(b) and Fig. 7(c) respectively. The experimental results show that the ECG signal measured by using the proposed non-contact electrode across thin clothing contains a little high-frequency interference. Next, the signal quality obtained by using the proposed non-contact electrode and the disposable surface electrode was evaluated using the linear correlation coefficient function in MATLAB (R2012a, MathWorks, Natick, MA) with randomly selected 1-minute ECG trials and their power spectra. The correlation of ECG signals obtained by using the proposed non-contact electrode and the disposable surface electrode in the time domain and in the frequency domain is about 98.43% and 97.09% respectively. Next, the measurement of ECG complex for different electrodes was tested. A total of 20-trial ECG records obtained from healthy participants were used for analysis. For the proposed non-contact electrode, the

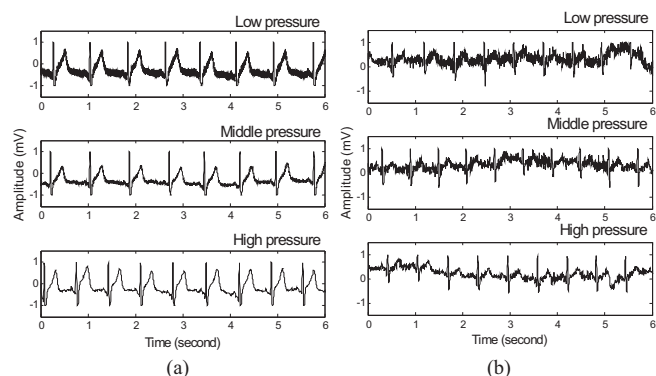

FIGURE 8. Comparison between ECG signal qualities by applying different pressures. (a) Static sitting posture: static state. (b) Walking: dynamic state.

amplitude and duration of QRS wave are 1.08 ± 0.0322 mV and 77.4 ± 7.279 ms. For the disposable surface electrode, the amplitude and duration of QRS wave are 1.05 ± 0.0293 mV and 77.05 ± 5.511 ms. The experimental results show that the ECG complexes measured by using the proposed non-contact and disposable surface electrodes are similar. The proposed non-contact electrode presents good performance for measuring bio-potentials across thin clothing.

C. EFFECT OF MOTION ARTIFACTS

In this section, the effect of motion artifacts on signal quality of the proposed non-contact electrode is investigated. In this experiment, a fixing waist belt was applied with different pressures to control the tightness between the body and the non-contact electrodes. Here, the applied pressure levels are high, middle, and low. Fig. 8(a) and Fig. 8(b) show the ECG signal qualities under static state (static sitting posture) and dynamic state (walking) respectively. Obviously, the ECG signal qualities with high pressure under both static and dynamic states provide better signal-to-noise ratio (SNR). And the ECG signal qualities become poorer as the applied pressure reduces. The experimental result for static state, can be explained by the fact that an increase in pressure can effectively reduce the distance between the electrode and the body to provide a larger equivalent capacitance of the skin-electrode interface and reduce the noise effectively. For dynamic state, the transversal motion and lateral motion [14] during walking will also result in a change in the skin-electrode interface equivalent capacitance and static electricity to induce more noise. Transversal motion and lateral motion can be effectively reduced while a high pressure is applied to increase the tightness between the body and the non-contact electrodes. Therefore, applying a higher pressure on the non-contact electrode can effectively increase the ECG signal quality.

D. ARRHYTHMIA ECG DETECTION

In this section, the proposed mobile ECG monitoring system is applied for monitoring the heart rate of patients with heart arrhythmia under motion and action. A total of

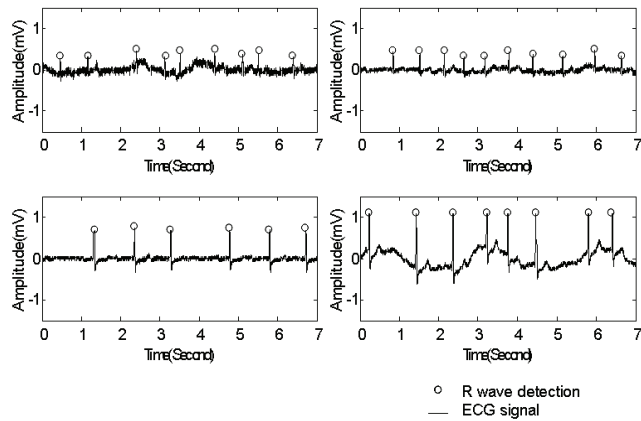

FIGURE 9. Four randomly selected results for measuring abnormal ECG signal and heart rate detection.

six patients with heart arrhythmia were tested. The age of the participants was from 40 to 70 years old. They were instructed to do bicycle or treadmill training for 20–40 minutes, while the proposed mobile ECG monitoring system was used to monitor lead-I ECG signal continuously. The clinical experiment was approved by the Institutional Review Board, Chi Mei medical center, Taiwan. Fig. 9 shows four randomly selected results of ECG measurement and heart rate detected by the QRS detection algorithm [16]. Although the sway and rub of the non-contact electrodes under motion and action resulted in noise, the features of ECG waveform can still be well recognized. And by using the QRS detection algorithm, the R wave can be easily detected.

Next, the practicability of detecting the heart rate of patients with arrhythmia was evaluated. Before evaluating the electrode performance at detecting heart rate, several parameters were first defined for the binary classification test: True Positive (There is a R wave in ECG, and it is correctly detected as a R wave), False Positive (There is not a R wave in ECG, but it is wrongly detected as a R wave), True Negative (There is not a R wave in ECG, and it is correctly detected as not a R wave) and False Negative (There is a R wave in ECG, but it is wrongly detected as not a R wave). The value of positive predictive value (PPV), sensitivity and accuracy can be calculated as follows:

$$PPV = \frac{\text{True Positives}}{\text{True Positives} + \text{False Positives}} \quad (1)$$

$$\text{sensitivity} = \frac{\text{True Positives}}{\text{True Positives} + \text{False Negatives}} \quad (2)$$

$$\text{accuracy} = 1 - \frac{\text{False Positives} + \text{False Negatives}}{\text{Number of total}} \quad (3)$$

The results for detecting heart rate are listed in Table I. The values of PPV, sensitivity, and accuracy of detecting the arrhythmia patients' heart rates by using the proposed non-contact electrode are about 98.54%, 99.75%, and 97.37% respectively. From the above results, the proposed non-contact electrode can be accurately applied for monitoring abnormal heart rate.

TABLE I. Performance of detecting abnormal heart rate by using proposed non-contact electrodes.

	Output of Detecting Heart Rate			
	R Wave	Not R Wave	Total	
ECG signal	R wave	2031 (TP)	24 (FN)	2055
	Not R wave	30 (FP)	5 (TN)	35
	Total	2061	29	2090

TABLE II. Comparison between different types of novel electrodes.

	Oehler et al. [10]	Matsuda et al. [11]	Eilebrecht et al. [13]	Chi et al. [14],[15]	Proposed electrode
Magnitude response at 0.1 and 100 Hz (dB)	2,2	-40,-25	-	1,-	-6.9,-3
Frequency band (Hz)	0.2~80	10~100	0.3~100	0.7~	0.5~1000
Input-referred noise at 10 Hz (uV rms)	5	3	-	2	3
Power consumption (W)	500mW (System)	-	-	940u (electrode), 300m (System)	240u (Electrode), 75 m (System)
Area of electrode (cm ²)	5.3	150	21	5.3	4
Applications	ECG	ECG	ECG	ECG, EMG, EEG	EMG, ECG

V. DISCUSSION

The specification comparison between different novel electrodes is summarized in Table II. The capacitive electrodes, proposed by Oehler et al. [10], consisted of an impedance converter, an amplifier and a band pass filter (0.2~80Hz), and its area is about 5.3 cm². A plastic film covering on the electrode plate was used to insulate, and a total of fifteen electrodes were fabricated as an electrode array. The power consumption of this electrode array is about 500 mW. The capacitively coupled electrode, proposed by Matsuda et al. [11], used an operational amplifier to connect with the conducting plate and embed in the inside of a car seat. The electrode conducting plate was made of a 150 cm² conductive textile sheet. The ground electrode was placed on the steering wheel to reduce interference when the hand of the user holds the steering wheel. The electrode matrix, proposed by Eilebrecht et al. [13], was constructed by using an active integrator and a high impedance component to form an impedance converter, with feedback connected to the input of the electrode plate to form a high pass filter. Moreover, a passive low-pass filter was connected to the output of the impedance converter to form the output of the electrode. Here, the conducting plate of the electrode is made of an aluminum plate without any insulation and the area of the electrode is about 21 cm². The above electrodes require a high-performance operational amplifier that provides low input bias current (~1 pA), high input impedance (~10T Ω), and low input capacitance (1~5 pF), to provide good performance for measuring bio-potentials. The non-contact electrode, proposed by Chi et al. [14], [15], contains an active electrode combined with the input capaci-

tance cancellation circuit and the bootstrap circuit. The input capacitance cancellation circuit used a capacitance to form feedback to the positive input of the operational amplifier to reduce the influence of input capacitance. The bootstrap circuit used capacitance to form feedback to the input resistance to enhance the input impedance. However, the capacitance and the factor of feedback usually vary with the distance between the electrodes and the body, and the bootstrap circuit also increases the required components.

The simple design of the non-contact electrode circuit was proposed in this study. The positive input of the operational amplifier was series connected to the electrode conducting plate and parallel connected to a couple diodes. Here, the couple diodes with 1pA reverse leakage current were used to form high input impedance, and discharge the electric charges between the conducting plate and the positive input of the operational amplifier. The impedance of the couple diodes is about $10G\Omega$ when the input signal is about $100\mu V$. The power consumption of the proposed non-contact electrode and the whole system are about 240 uW and 75 mW respectively. Here, the major power draw of the system is the Bluetooth wireless communication at about 73 mW. The experimental results show the proposed non-contact electrode can provide good performance for measuring bio-potentials, and the number of the required components and the power consumption can be effectively reduced.

VI. CONCLUSION

A new simplified non-contact electrode circuit was proposed in this study. Simplifying the design of the non-contact electrode can effectively reduce its power consumption. The experimental results show that the frequency band of the proposed non-contact electrode is between 0.5 Hz and 10000 Hz, and the correlation of signal qualities using the non-contact electrode and conventional ECG electrode is high. Therefore, it is suitable for measuring ECG signals and most bio-potentials. The effect of motion artifacts on the signal quality of the non-contact electrode was also investigated. The experimental results show applying suitable pressure to reduce the transversal motion and lateral motion of the non-contact electrode can effectively improve the signal quality, even while exercising. Finally, the proposed mobile ECG monitoring system was applied to detect arrhythmia. The experimental results show that both of the sensitivity and accuracy for detecting arrhythmia by using the proposed non-contact electrode are high and it can be accurately applied for monitoring abnormal heart rate. Using non-contact electrodes, users can monitor their ECG across thin clothing and avoid the issues of skin irritation and discomfort. The above experimental results show that the proposed non-contact electrode presents an effective way to acquire bio-potentials without contacting the skin directly, and is practicable to be embedded in normal clothing for long-term ECG monitoring in daily life.

REFERENCES

- [1] Y. H. Lin, I. C. Jan, P. C. I. Ko, Y. Y. Chen, J. M. Wong, and G. J. Jan, "A wireless PDA-based physiological monitoring system for patient transport," *IEEE Trans. Inf. Technol. Biomed.*, vol. 8, no. 4, pp. 439–447, Dec. 2004.
- [2] E. Kafeza, D. K. W. Chiu, S. C. Cheung, and M. Kafeza, "Alerts in mobile healthcare applications: Requirements and pilot study," *IEEE Trans. Inf. Technol. Biomed.*, vol. 8, no. 2, pp. 173–181, Jun. 2004.
- [3] B. S. Lin, B. S. Lin, N. K. Chou, F. C. Chong, and S. J. Chen, "RTWPMS: A real-time wireless physiological monitoring system," *IEEE Trans. Inf. Technol. Biomed.*, vol. 10, no. 4, pp. 647–656, Oct. 2006.
- [4] M. F. A. Rasid and B. Woodward, "Bluetooth telemedicine processor for multi-channel biomedical signal transmission via mobile cellular networks," *IEEE Trans. Inf. Technol. Biomed.*, vol. 9, no. 1, pp. 35–43, Mar. 2005.
- [5] R. G. Lee, K. C. Chen, C. C. Hsiao, and C. L. Tseng, "A mobile care system with alert mechanism," *IEEE Trans. Inf. Technol. Biomed.*, vol. 11, no. 5, pp. 507–517, Sep. 2007.
- [6] U. Anliker, J. A. Ward, P. Lukowicz, G. Tröster, F. Dolveck, M. Baer, F. Keita, E. B. Schenker, F. Catarsi, L. Coluccini, A. Belardinelli, D. Shk-larski, M. Alon, E. Hirt, R. Schmid, and M. Vuskovic, "AMON: A wearable multi-parameter medical monitoring and alert system," *IEEE Trans. Inf. Technol. Biomed.*, vol. 8, no. 4, pp. 415–427, Dec. 2004.
- [7] M. Catrysse, R. Puers, C. Hertleer, L. Van Langenhove, H. Van Egmond, and D. Matthey, "Toward the integration of textile sensors in a wireless monitoring suit," *Sens. Actuators A, Phys.*, vol. 114, nos. 2–3, pp. 302–311, 2004.
- [8] L. Beckmann, C. Neuhaus, G. Medrano, N. Jungbecker, M. Walter, T. Gries, and S. Leonhardt, "Characterization of textile electrodes and conductors using standardized measurement setups," *Physiol. Meas.*, vol. 31, no. 2, pp. 233–247, 2010.
- [9] C. T. Lin, L. D. Liao, Y. H. Liu, I. J. Wang, B. S. Lin, and J. Y. Chang, "Novel dry polymer foam electrodes for long-term EEG measurement," *IEEE Trans. Biomed. Eng.*, vol. 58, no. 5, pp. 1200–1207, May 2011.
- [10] M. Oehler, V. Ling, K. Melhorn, and M. Schilling, "A multichannel portable ECG system with capacitive sensors," *Physiol. Meas.*, vol. 29, no. 7, pp. 783–793, 2008.
- [11] T. Matsuda and M. Makikawa, "ECG monitoring of a car driver using capacitively-coupled electrodes," in *Proc. Int. Conf. IEEE Eng. Med. Biol. Soc.*, Aug. 2008, pp. 1315–1318.
- [12] H. J. Baek, G. S. Chung, K. K. Kim, and K. S. Park, "A smart health monitoring chair for noninvasive measurement of biological signals," *IEEE Trans. Inf. Technol. Biomed.*, vol. 16, no. 1, pp. 150–158, Jan. 2012.
- [13] B. Eilebrecht, A. Schommartz, M. Walter, T. Wartzek, M. Czaplak, and S. Leonhardt, "A capacitive ECG array with visual patient feedback," in *Proc. Int. Conf. IEEE Eng. Med. Biol. Soc.*, Aug.–Sep. 2010, pp. 6539–6542.
- [14] Y. M. Chi, T. P. Jung, and G. Cauwenberghs, "Dry-contact and noncontact biopotential electrodes: Methodological review," *IEEE Rev. Biomed. Eng.*, vol. 3, pp. 106–119, Oct. 2010.
- [15] Y. M. Chi, Y. T. Wang, Y. Wang, C. Maier, T. P. Jung, and G. Cauwenberghs, "Dry and noncontact EEG sensors for mobile brain-computer interfaces," *IEEE Trans. Neural Syst. Rehabil. Eng.*, vol. 20, no. 2, pp. 228–235, Mar. 2012.
- [16] C. T. Lin, K. C. Chang, C. L. Lin, C. C. Chiang, S. W. Lu, S. S. Chang, B. S. Lin, H. Y. Liang, R. J. Chen, Y. T. Lee, and L. W. Ko, "An intelligent telecardiology system using a wearable and wireless ECG to detect atrial fibrillation," *IEEE Trans. Inf. Technol. Biomed.*, vol. 14, no. 3, pp. 726–733, May 2010.



BOR-SHYH LIN (M'02) received his B.S. degree from National Chiao Tung University, Hsinchu, Taiwan, in 1997, the M.S. degree in electrical engineering from National Taiwan University, Taipei, Taiwan, in 1999, and the Ph.D. degree in electrical engineering from National Taiwan University, in 2006.

He is currently an Assistant Professor with the Institute of Imaging and Biomedical Photonics, National Chiao Tung University. His current research interests include biomedical circuits and systems, biomedical signal processing, and biosensors.



WILLY CHOU received his B.S. degree in medicine from National Taiwan University, Taipei, Taiwan, in 1989, and his M.S. degree in human resource management from National Sun Yat-Sen University, Kaohsiung, Taiwan, in 2003.

He is currently an Assistant Professor with the Department of Leisure Management, Cha Nan Pharmacy & Science University, Taiwan. He is the Director of the Physical Medicine & Rehabilitation Department, the Chief of the Human Resource Department, and Secretary of Medical Affairs of Chimei Medical Center, Chimei, Taiwan. His current research interests include biomedical assistive devices and rehabilitation medicine.



HSING-YU WANG received his B.S. degree from the National Taipei University of Technology, Taipei, Taiwan, in 2009, and his M.S. degree in electrical engineering from National Chiao Tung University, Hsinchu, Taiwan, in 2012.

His current research interests include biomedical circuits and systems and biosensor.



YAN-JUN HUANG received his B.S. degree from National Sun Yat-Sen University, Kaohsiung, Taiwan, in 2012. He is currently pursuing his Master's degree with the Institute of Imaging and Biomedical Photonics, National Chiao Tung University, Hsinchu, Taiwan.

His current research interests include biomedical circuits and systems and biosensors.



JENG-SHYANG PAN (M'01–SM'09) received his B.S. degree in electronic engineering from the National Taiwan University of Science and Technology, Taipei, Taiwan, in 1986, his M.S. degree in communication engineering from National Chiao Tung University, Hsinchu, Taiwan, in 1988, and his Ph.D. degree in electrical engineering from the University of Edinburgh, Edinburgh, U.K., in 1996.

He is currently a Professor with the Department of Electronic Engineering, National Kaohsiung University of Applied Sciences, Kaohsiung, Taiwan. He was invited to be the Doctoral advisor with the University of South Australia and the Harbin Institute of Technology, Harbin, China. His current research interests include soft computing, information security, and signal processing.

Dr. Pan is a fellow of the IET, UK, and Vice Chair (Industrial) of the IEEE Tainan Section and the Tainan Chapter Chair of the IEEE Signal Processing Society.