

User Centered Neuro-Fuzzy Energy Management Through Semantic-Based Optimization

Shaun K. Howell¹, Hendro Wicaksono, Baris Yuce², *Member, IEEE*, Kris McGlinn, and Yacine Rezgui³

Abstract—This paper presents a cloud-based building energy management system, underpinned by semantic middleware, that integrates an enhanced sensor network with advanced analytics, accessible through an intuitive Web-based user interface. The proposed solution is described in terms of its three key layers: 1) user interface; 2) intelligence; and 3) interoperability. The system’s intelligence is derived from simulation-based optimized rules, historical sensor data mining, and a fuzzy reasoner. The solution enables interoperability through a semantic knowledge base, which also contributes intelligence through reasoning and inference abilities, and which are enhanced through intelligent rules. Finally, building energy performance monitoring is delivered alongside optimized rule suggestions and a negotiation process in a 3-D Web-based interface using WebGL. The solution has been validated in a real pilot building to illustrate the strength of the approach, where it has shown over 25% energy savings. The relevance of this paper in the field is discussed, and it is argued that the proposed solution is mature enough for testing across further buildings.

Index Terms—ANN, data mining, energy management, fuzzy logic, genetic algorithm, ontology, optimal control, semantic Web, WebGL.

I. INTRODUCTION

PUBLIC buildings have substantial proliferations of control/automation technologies and tend to experience large discrepancies between “designed” and “operational” energy use, as well as increased user comfort dissatisfaction [1], [2]. Actual energy performance can be considered as the result of a complex combination of, and interaction between, three factors: 1) intrinsic quality of the building; 2) “in use” conditions and user behavior; and 3) energy control and actuation strategy [3], [4]. Whilst altering factor

1) requires complete and costly energy retrofitting interventions, academic evidence suggests that factors 2) and 3) play a determinant role in the energy equation of a building [5]. Managing energy performance implies the ability to monitor and characterize usage patterns whilst understanding user behavior and comfort aspirations in order to devise user centered real-time energy optimization plans. However, energy control is usually handed to smart systems that 1) do not offer flexibility in responding to unforeseen situations or needs or 2) exhibit a level of complexity that hinders their effective use by facility managers [6].

Moreover, building energy interventions have been designed without taking into account the need to negotiate energy use and desired environmental conditions [1], [6]. Building management systems (BMSs) can be seen as the interface between energy systems and users, including facility managers (FMs). On the one hand, occupants need to feel an engagement with the process of regulating their energy usage in a way that enhances their living and working experience in buildings; conversely, energy control systems should have a level of intelligence and interactivity that promote user-centered and negotiable (multiobjective) energy optimization strategies [2], [5].

Existing BMS in research and industry have shown: 1) various adoption and use problems which suggest a lack of understanding of users’ expectations in terms of levels of automation and functionality; 2) limitations in their capacity to factor in (near) real-time dynamic changing conditions, as well as addressing; and 3) often conflicting multiobjective goals, e.g., reducing energy while enhancing occupants’ comfort and working experience [2]. State-of-the-art research in BMSs involves the use of semantic-based real-time sensing tools [7]–[9] that factor in space occupancy patterns as well as user comfort feedback. However, these tools need to promote more effective energy control strategies through enhanced interoperability with existing energy modeling environments, building control systems, and operational log feeds, and deliver higher-order intelligence (through correlation and analysis of energy modeling predictions and actual use), accessible through more intuitive user-interfaces.

This paper proposes a methodology that exploits finer integration of sensing, interoperability, intelligence, and user interfaces to confer FMs the desired levels of interaction (including automation and functionality) with the BMS to address a wide range of energy scenarios. This builds on prior work [7], [10], following further experimentation with the approach, development of the underpinning software

Manuscript received January 6, 2018; revised April 18, 2018; accepted May 18, 2018. Date of publication July 17, 2018; date of current version June 6, 2019. This work was supported by the European Commission in the Context of the KnoholEM Project through the EEB-ICT-2011.6.4 (ICT for energy-efficient buildings and spaces of public use) Program under Grant 285229. This paper was recommended by Associate Editor P. P. Angelov. (*Corresponding author: Shaun K. Howell.*)

S. K. Howell and Y. Rezgui are with the Cardiff School of Engineering, Cardiff University, Cardiff CF24 3AA, U.K. (e-mail: howellsk5@cardiff.ac.uk).

H. Wicaksono is with Jacobs University Bremen gGmbH, 28759 Bremen, Germany (e-mail: h.wicaksono@jacobs-university.de).

B. Yuce is with the College of Engineering, Mathematics and Physical Sciences, University of Exeter, Exeter EX4 4QF, U.K.

K. McGlinn is with the School of Computer Science and Statistics, University of Dublin Trinity College, Dublin, Ireland.

Color versions of one or more of the figures in this paper are available online at <http://ieeexplore.ieee.org>.

Digital Object Identifier 10.1109/TCYB.2018.2839700

platform and algorithmic design, and pilot site validation, which are the focus of this paper. Following the introduction, this paper critically discusses related research, identifying gaps to be addressed by this paper. Section III illustrates the overarching methodology and the various underpinning components delivering a semantic negotiable strategy for energy management. The subsequent sections then detail each of these components, namely: semantic Web middleware (Section IV), rule-based analytics (Section V), and smart GUI (Section VI). This paper then presents the validation of the approach in a public care home building in The Netherlands. This paper discusses the proposed approach and provides concluding remarks and directions for future research.

II. BACKGROUND

A. Toward Economic, Extensible, and Integrated Retrofit BEMS Solutions

Building energy management systems (BEMSs) aim to improve the energy performance of operational buildings. They work on the principle of collecting data about the current state of a building, analyzing this data, then providing feedback to the appropriate decision maker, or reconfiguring the building automatically.

Such a system can be conceptualized in different architectural layers; a sensor layer, computational layer, and an application layer [11]. The sensor layer includes all the energy and environment monitoring devices, the computational layer analyses this data to generate knowledge and desired actuations. The application layer then either acts on this automatically, or provides decision support through a user interface which may also send notifications to stimulate behavioral change and feedback. An alternative architecture is presented in [2], which includes a middleware layer between the sensor and analytics layers. This middleware connects the distributed infrastructure of sensors and actuators with the processing engine, and is responsible for handling heterogeneity and interoperability. Other architectural configurations for buildings and smart homes were observed [12], [13], each sharing a similar layered architecture.

The reduction of energy consumption through a BEMS requires it to be economic and engaging for the decision maker, and to deliver integrated, accurate, and attractive measures for energy saving. This requires the extension of the state of the art at both the analytics and interface levels. However, it must also be suitable for retrofit into buildings with existing sensor networks of heterogeneous components and be extensible, as the state of the art continues to improve, so must also innovate in the middleware BEMS layer. To this end, recent advances in each of these three layers are now reviewed in turn: 1) middleware; 2) analytics; and 3) interfaces.

B. Interoperating Legacy Systems With Advanced Analytics—The Role of Semantic Middleware

A flexible and thorough middleware solution is essential to interoperate between the existing sensor and management systems in a building and the novel analytics and

visual components of a retrofitted BEMS. Whilst interoperable data exchange protocols are critical [14], and other barriers, such as data quality, integrity, and security exist [15], interoperability of data formats and meaning is a critical challenge in ICT interventions in the built environment [14]–[16]. This highlights the key challenges in energy management interoperability of both shared syntax and semantics between ICT components. These incompatibilities currently require *ad-hoc* mappings for effective communication and interoperation with a retrofitted BEMS.

Instead, a common vocabulary and conceptual model mitigates the effort required for software artefacts to communicate effectively in an energy management system [9], [14]–[17]. Such artefacts are referred to as semantic models, and are being developed using the Web ontology language (OWL), to facilitate the semantic Web [9], [18], [19], Internet of Things [20], and linked data [21]. These ontological semantic models standardize the description of concepts, relationships, and properties in the domain.

In the built environment domain, the openBIM IFC data model is already experiencing strong uptake [22]. This model uses a less expressive format than OWL, and its federation into OWL is an active area of research [23]. Whilst this does not sufficiently model energy management concepts, its extension toward BEMS would improve the adoption of the resulting model.

The ISES project used an OWL-DL ontology to address interoperability in an integrated lifecycle BEMS [24]. Also, the HESMOS project developed an ontology-equipped framework to integrate distributed and heterogeneous data from ICT building energy systems [25]. However, these projects do not strongly consider their alignment with existing standards, such as the IFC, and do not model occupant behavior. This gap is therefore addressed by the ontological middleware developed for the presented BEMS solution.

C. State of the Art of BEMS Rule Generation and Application

One of the biggest built environment challenges is the need for adaptive, autonomous, and replicable management solutions. Thus, several retrofit building energy management and control systems exist [26], [27], which use intelligent approaches to deal with complexity and uncertainty [28]–[30]. Whilst this can also be achieved through a semantic-based approach [31], this typically requires domain expert knowledge, although automated knowledge discovery processes are emerging [32]–[39].

Several rule generation and knowledge discovery processes exist, such as rule mining [32], combined mining [33], cooperative rules [34], neural network [35], fuzzy logic [36], fuzzy rough set [37], genetic algorithm [38], ant colony optimization [39], hybrid algorithms [7], [40], evolving fuzzy systems [41], [42], decision trees [43], [44], fuzzy classifiers [45], fuzzy pattern trees [46], and rule ripping approaches [47]. These provide a flexible method of approximating rules in a data driven way and highlight the suitability

of machine learning [40] and well-trained ANNs [27] for approximating highly nonlinear problems.

Mitra and Hayashi [40] proposed a neuro-fuzzy rule generation framework, capturing the strengths of both neural networks and fuzzy systems for use in the area of medical diagnosis. Neural networks perform well in data driven processes, providing a continuous learning ability, and fuzzy systems perform well in logic-based systems. Combining the two approaches therefore presents merits in data driven, logical systems. However, they have not compared their algorithm with other prominent rule generation algorithms.

Finally, Pal and Pal [38] proposed a self-organized rule generation process for a fuzzy controller, through a genetic algorithm. This selected the optimal number of rules without supervision, eliminating the need for expert involvement. They tested their solution on an inverted pendulum; reducing the number of rules by circa 95%, and resulting in an integral absolute time error of 0.1019. However, their approach did not optimize the membership functions of the fuzzy inference engine, which could increase the robustness of their approach.

The strengths and weaknesses of the rule generation techniques presented above vary across different types of problem, and they could be improved through multi combined approaches, such as using neural network-based optimization processes. Moreover, they could be extended with advanced partitioning techniques, such as PCA, or other fast classifiers, although PCA may not perform well with large numbers of inputs. This weakness can be avoided by also using multi regression analysis (MRA), where PCA determines the required number of classes and MRA can then determine these classes, using a regression coefficient. Therefore, hybrid processes deliver the strengths of several approaches, especially regarding data driven processes [48], although this has to be logically linked well with other methods.

D. Toward Engaging Interface for Building Energy Monitoring and Decision Support

The final layer of the BEMS system is the application layer, which allows the FM to interact with the system's data monitoring, analytics, and actuation capabilities. Several commercial energy monitoring tools exist, which allow the monitoring of energy consumption in a building. MonaVisa is a product which is retrofitted alongside an existing BMS [49]. This collects temperature and CO₂ sensor readings and assesses these against a comfort range, generating a notification when a KPI leaves this range. These assessments are conducted at different time scales for each monitored room and are delivered through a GUI. PlugWise is an energy monitoring tool which transmits energy readings over the ZigBee protocol. This allows additional sensors to be added to monitor temperature, motion, gas, and electricity. Again, collected readings can be viewed as charts and graphs for each metered appliance over varying time scales, and overlaid onto a 2-D floorplan.

Increasingly, these sensing, analytics, and actuation services are delivered through WebApps. These aim to provide engaging interfaces with seamless cross-platform deployment. HTML5 provides a flexible and extensible means to meet the

requirements of many tools, and Asynchronous JavaScript and XML (AJAX) and SPARQL queries can be used to access the underpinning knowledge. Further, WebGL facilitates 3-D visuals in HTML5 Web pages without the need for browser plugins, as HTML5 is supported natively by modern browsers. This is highly beneficial because it allows deployment across operating systems, other Web page elements can form part of the GUI, and the visuals can make use of a number of high-level communications tools, such as AJAX. The 3-D graphics software interface to WebGL is written in JavaScript, which allows the use of the document object model to manipulate the Web page, and allows the visualization to be manipulated by standard Web form controls. Finally, as this allows the seamless integration of 3-D visualizations with Web technologies, it allows the computationally expensive simulation and analytics tasks to be performed on the server side, with only the rendering of 3-D data performed by the user's Web client.

III. OVERVIEW OF PROPOSED SOLUTION

The research and development of a novel BEMS was undertaken through an EC FP7 project [50] and tested within a mixed mode residential care home in The Netherlands. The project aimed to produce a BEMS, which could be retrofitted into public buildings with minimal investment, to exploit an enhanced sensing infrastructure and the existing BEMS, augmented with analytics and visualization components through a semantic Web approach. This involves a semantic knowledge base, which describes the physical properties of the building as an extension of the openBIM IFC data model [18], [23], through an RDF store and SPARQL endpoint. The semantic model in the knowledge base also contextualizes the historical data stored in an MySQL database by formalizing a shared meaning. The novel analytics include the automated production of rules through simulation-based rule generation [7] and their subsequent fuzzification alongside rules from mining on historical metering data. The visualization component utilized an HTML5-based smart GUI to deliver engaging 3-D WebGL visuals alongside real-time and historical energy performance monitoring and decision support, by presenting the optimized rules as user-friendly actuation suggestions. The BEMS aimed to promote trust with FMs through a negotiation-based user-in-the-loop approach. This meant the FM was responsible for actuating the suggested changes, as this was attractive to industrial partners due to liability and legislation concerns around automated actuation. Finally, the semantic Web-based approach aimed to promote reusability and extensibility, by allowing the deployment of the BEMS in further buildings without redesign of its underlying technologies, as was tested through four other European pilot sites within the project. This paper focusses on presenting the enhanced BEMS and delivering proof of concept at the selected pilot site. The following sections therefore discuss the key components of the proposed system's service-oriented architecture; the RDF store, SPARQL mapper, and knowledge base which constitute the semantic middleware, the data mining engine, rule engine, and fuzzy real time reasoner, which constitute the system's analytics components, and the system's smart GUI, as shown in Fig. 1, before a pilot site validation is presented.

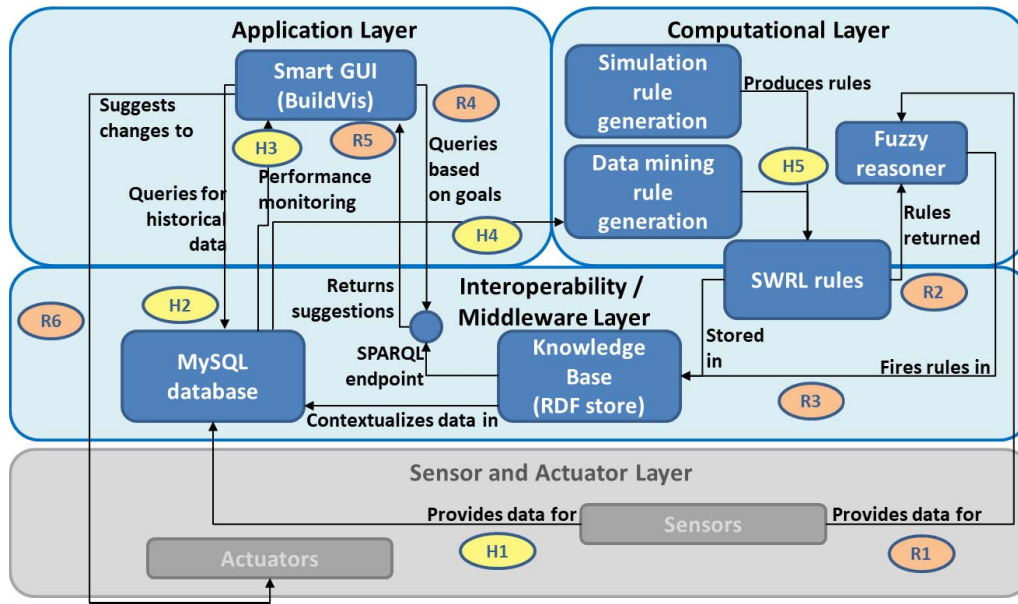

Fig. 1. Architecture of the proposed solution.

The numbers H1-H5 and R1-R6 in Fig. 1. describe the two data flows involved in the proposed solution, i.e., historical and real-time data flows. Each data collected from sensors is transmitted through Web service interface into the MySQL database periodically in a certain interval resulting in a collection of historical data (H1). Through the BuildVis interface, the user can query the historical data to perform performance monitoring, for example to monitor the energy performance of certain building zone in a specified time range (H2–H3). The historical data stored in the MySQL database are then used as training data by machine learning algorithms to generate rules (H4). The resulting rules are transformed into SWRL rules and integrated into the knowledge base (H5). The rule generation is performed in a larger interval to update the knowledge, for example once in a month.

Through the Web service interface, the fuzzy reasoner collects data from the sensors in real time (R1). Then, it invokes the appropriate rules, i.e., rules with certain weights in the knowledge base that have been selected by the user (R2). The fuzzy reasoner fires the rules by setting the variables in the condition part with the values collected from the sensors (R3). Through BuildVis GUI, the user can define an energy saving goal of a certain category in his building, for example 10% energy saving for heating (R4). The knowledge base returns the suggestions containing set points values of different actuators to achieve the desired goal (R5). Subsequently, the user could set the set points corresponding to the suggested values (R6).

To summarize the relationships between the core analytics components: a genetic algorithm generates energy-saving rules, using an ANN as the cost function (as a surrogate for the thermal simulation), these rules map the current building state and actuator states to optimal actuator states for the imminent future. The rules are fuzzified and then stored in the knowledge base, and updated on a periodic basis (e.g., weekly). The rules are used by the fuzzy reasoner at runtime alongside

actual sensor data, where the fuzzy reasoner recommends the best actuator state given the current observed building state and actuator states.

IV. SEMANTIC WEB MIDDLEWARE

A. Role of Semantic Middleware

As mentioned, a critical problem in retrofitting advanced analytics into existing buildings is the range of heterogeneous data sources and existing BEMS solutions encountered: such as (in our pilot case study) Priva, Controlli, and EUGENE. This was overcome through a key novelty of this paper; the knowledge base and accompanying software which served as the integration components of the proposed energy management system. It integrates heterogeneous data sources required by the system, and also provides some of the intelligence capabilities through reasoning on the rules and structures contained in the knowledge base.

Each of existing BEMS solution uses different communication protocol, for example, EUGENE uses Modbus and Priva uses BACNet. However, they provide Web service REST interface. The data are transmitted from those BEMS solution to the middleware layer through REST Web service. We developed a program to perform the mapping between the Web service schema and our knowledge base model.

The approach of a semantic middleware solution was adopted over traditional options to facilitate reuse and extensibility in the BEMS domain and the wider domains of smart cities and the Internet of Things, and to build the BEMS solution in line with the wider trend toward Web-based software. Through this approach, the proposed solution could be deployed in further buildings regardless of the proprietary data schemas and protocols used by their previously installed sensing, actuation, and BEMS infrastructure, and could be used to integrate building energy management with energy

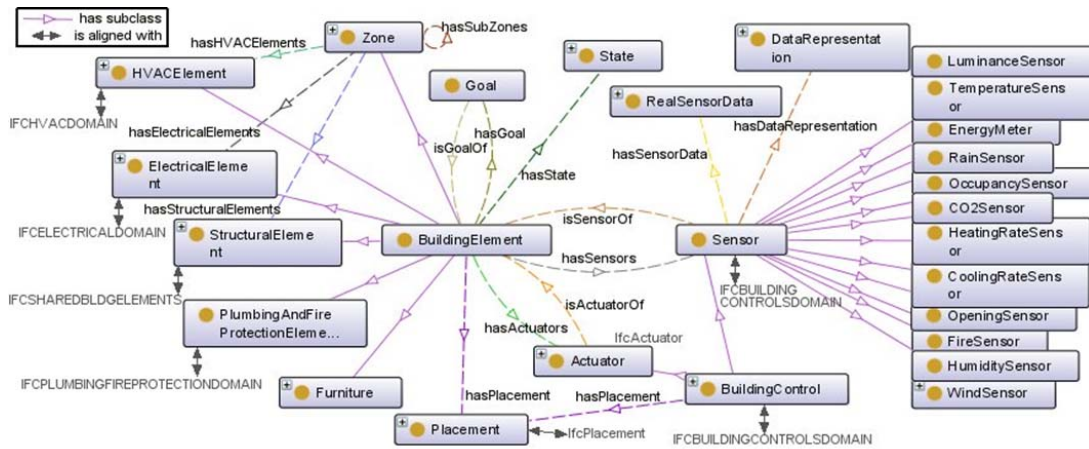

Fig. 2. Main concepts, relationships, and IFC mappings in the domain ontology.

management at the district scale, such as, where renewables or microgrids require active and collaborative management [51].

B. IFC-BEMS Domain Ontology

The OWL was used to represent the knowledge base in order to achieve a high degree of expressiveness of the knowledge model. The knowledge domain model consists of classes representing building physical elements that are observed and analyzed in energy management activities, and building controls consisting of sensors, controllers, alarm, etc., which act as observer and controller of physical building elements. Furthermore, the knowledge model represents the human actors and their behaviors that can affect the states of building physical elements. In the knowledge model, the states are classified into simple states, for example window or room states, and complex states, which are built by relating several simple states. Energy efficiency and comfort degrees are examples of complex states. This resulted in 145 asserted classes, 43 object property slots, and 43 data property slots; the key physical and sensory classes and relationships are shown in Fig. 2.

In order to provide the possibility to reuse existing industrial standards, the knowledge domain model is aligned to IFC model, as also shown in Fig. 2. The alignment is done by defining the explicit IFC-OWL mappings that are stored in the class annotations. For example, the IFC entity *IfcWindow* is mapped to OWL class *Window* using the annotation *correspondToIfcEntity*. The other main IFC concepts which were reused were the physical building elements and geometries, such as doors, walls and openings, and the key extensions included descriptions of the zones, sensors, states, people, and behaviors in the domain. In total the domain ontology asserted 44 mappings to IFC concepts. This allowed an automatic IFC to OWL document conversion using SPARQL queries [23].

C. Population of Pilot Site Knowledge Base

The domain ontology model only contained classes, relations among them, and definition of their properties. In order

to apply the knowledge base in a specific building, the ontology had to be populated with instances corresponding to the objects in the building that are considered essential for the energy management activities. Most current building layouts are only drawn as 2-D sketch using CAD applications, such as AutoCAD [52]. They contain only geometrical primitives, such as lines, curves, points, etc. Therefore, in order to populate the ontology, the semantic information of the sketch had to be extracted. OntoCAD is an open source tool that was developed to solve the problem. The tool clusters the geometric primitives in layers. Using the tool, we defined templates representing semantic objects, such as doors, rooms, and chairs, and select the areas in the drawing which corresponded to the to-be-generated ontology instances. The tool updated the property values of the generated instance automatically, such as the position and the perimeter. OntoCAD also allowed the validation and correction of the knowledge population, where necessary [53].

The knowledge base also embeds SWRL rules, which are generated automatically using both historical metering (generated through data mining) and simulation data. Each rule is equipped with a weight indicating the confidence of the rule. The weight has values between 0 and 1. These are used by the fuzzy reasoner to evaluate the importance of the rules. This is necessary to account for the large number of rules generated by the data mining and simulation modules. As well as these custom rules, the ontology deployment performs inference through the Jena inference module. This allows new knowledge to be produced automatically by the software from the stated axioms, resulting in inferred knowledge being used alongside explicit knowledge. For example, if a sensor is stated to be connected to a specific element, as a property of the sensor, then the software infers as a property of the building element, that the element has that sensor connected.

D. RDF Store and SPARQL Endpoint

This module is the main communication module between the knowledge base and the smart GUI. The knowledge base stores all the data about the building and its systems relevant to

```

prefix kno:
<http://www.semanticweb.org/ontologies/2012/9/knohol
em.owl#>
SELECT ?zone_name ?x_coord ?y_coord ?perimeter
WHERE
{?zone<http://www.w3.org/1999/02/22-rdf-syntax-
ns#type> <kno:Zone>;< #hasName> ?zone_name.
?zone <kno:hasPerimeter> ?perimeter.
?zone <kno:hasPlacement> ?sym.
?s sym <kno:hasXCoord> ?x_coord.
?s sym <kno:hasYCoord> ?y_coord.}

```

Fig. 3. Example of an SPARQL query.

the BEMS. To enable visualization of the building floor plan, an existing 2-D DWG file is parsed and converted directly into RDF and stored on the Fuseki server. The data extraction tool OntoCAD is used to identify zones in the building and add additional information as sensor types and locations. This information is also stored as an OWL file and uploaded into a Fuseki server which is running on a linux operational system-based virtual platform, and maintained by the Knowledge and Data Engineering Group in Trinity College Dublin [54]. Each pilot building has its own instance of Fuseki server to store the building specific knowledge base. The smart GUI queries the ontology using a combination of AJAX and SPARQL (SPARQL Protocol and RDF Query Language). When the FM selects the pilot building through the smart GUI, several SPARQL queries are made to the Fuseki server, one of which returns JSON objects which are then used to store a 2-D array of JavaScript zone objects, which describe each zone in the building. A query example is shown in Fig. 3. This would be enough to display the zones graphically (using WebGL), although as each property is returned as strings, perimeters must be parsed client side to get each point given in Fig. 3.

V. OPTIMIZED RULE-BASED ANALYTICS

In order to enhance the reasoning capabilities of the knowledge base, we integrated rules from data mining over sensor data, and rules from thermal simulation-based optimization. The rules are represented with SWRL in order to allow the integration into the knowledge base. The data mining rules are mainly used to identify inconsistent performance and to predict energy consumption in the building. Conversely, the simulation-generated rules aim to impose optimal set point configurations toward the negotiated target energy saving. Both rule types are critical to the BEMS's capability to assist FMs in improving energy efficiency in the building. The main reason for utilizing the simulation-based rules in the proposed methodology was the complex behavior of the building environments, which could not be fully captured by rules without a simulation model and a robust intelligent solution. The following sections present the generation approaches of both rule types. Nevertheless, this paper focuses on simulation rules and only introduces data mining rules briefly, as they are described in [23].

A. Extraction of Rules Through Data Mining on Historical Metering Data

The objective of the data mining was to identify correlations between indoor and outdoor sensor data, user behaviors, and energy consumption data, and to express these as rules. The rules were then federated into SWRL rules in the knowledge base to enrich each building's model. Reasoning on the rules generated new knowledge that can be utilized for the following goals.

- 1) Prediction of the energy consumption of certain user activities, building zones, and appliances.
- 2) Detection of energy consumption anomalies in user activities, zones, and appliances.
- 3) Inference of user activities in building or zones based on contextual sensor data.
- 4) Fault detection in appliances, based on their energy consumption.
- 5) Prediction of actuator states or configurations toward meeting specific comfort levels.

These intelligent capabilities were achieved through the collection and algorithmic analysis of the following relevant sensor data.

- 1) *Indoor Sensor Data*: Zone temperatures, CO₂ concentrations, and door and window states.
- 2) *Outdoor Sensor Data*: Dry-bulb temperature, precipitation rate, wind speed, brightness/luminance, and air humidity.

To allow different analyses at different aggregation levels, energy consumptions were collected using energy meters at various levels. At the appliance level, energy meters were installed at active power sockets. At the zone level, energy meters were installed at the distribution board for the target zone. At the building level, energy meters were installed in the central distribution board.

Behavioral data were then collected; mainly based on the usage of appliances and zone occupancies. That meant that if a user undertook multiple activities in a zone without changing the appliance usage, those activities were not considered as different behaviors. Key daily periods were identified, where similar behaviors were observed across days: lunch time, office hours, coffee break time, maintenance/cleaning time, and nonoffice hours.

The rules reflecting interrelationships between behavior, surroundings parameters (temperature, humidity, etc.) and energy consumption were generated through decision tree-based classification algorithms, such as C4.5 [43]. Each path in the decision tree from the root to the leaf constitutes a rule.

B. Simulation-Based Optimized Rule Generation

This system module used a 6-staged process to produce energy saving rules based on thermal simulations of the building, as shown in Fig. 4. This approach uses preprocessing to produce optimization scenarios and simulation data, and to identify sensitive variables, then trains an ANN based on this data. This ANN is then used as the cost function in a GA optimization to output actionable rules, which are then evaluated for efficacy.

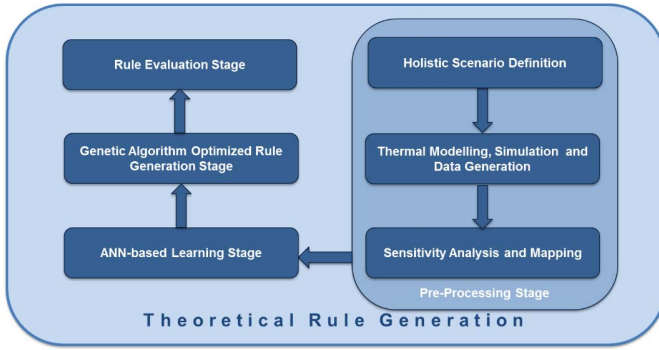

Fig. 4. Simulation-based rule generation method environmental variables.

TABLE I
PROPOSED SCENARIO FOR FORUM BUILDING

Scenario Actor	Holistic Solution
Scenario Definition	This scenario provides a negotiation based holistic solution to FORUM building ATRIUM zone by minimising energy consumption and optimising the comfort
Control Variables	<ul style="list-style-type: none"> Heating temperature set point : [18°C- 24°C], (incremental size =2) Atrium roof window set point (state): {Off=0, On =1} Lighting set point (state): {Off=0, On =1} Shading set point (state): {Off=0, On =1}
Objectives	<ul style="list-style-type: none"> Desired amount of minimisation for energy consumption Comfort (Predicted Mean Vote (PMV)) optimisation.
Control Rules	Legislation regarding required internal temperatures will need to be adhered to at all times.
Actors	Occupancy sensors, light automation system, automation system, facility manager, technician, temperature regulatory valves, actuators, temperature sensors, weather station, window actuator, shade actuator.

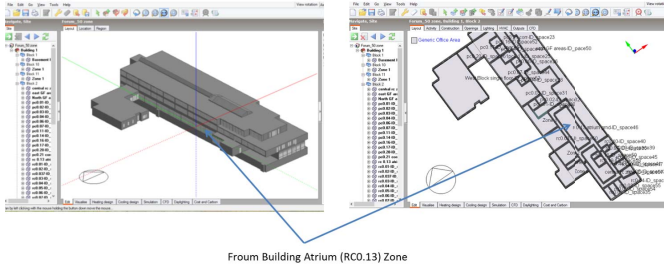

Fig. 5. Thermal model for forum building's atrium zone (pilot zone).

1) Building Thermal Simulation and Sensitivity Analysis:

The preprocessing stage consists of scenario definition, simulated data generation, sensitivity analysis, and variable mapping. The scenario defines the objectives of the optimization and the available control variables, actors, and sensors. Thermal simulation and data generation involves thermal model development and utilization for each building. Sensitivity analysis and variable mapping then determines the most sensitive variables, and maps them with the building's artefacts, as expressed in the knowledge base.

In this paper, a public residential care home in The Netherlands, named “the Forum,” was used as a case study, based on the scenario shown in Table I. A thermal simulation model of the building was created in DesignBuilder, as shown in Fig. 5, which includes detailed material, occupancy, and construction data.

TABLE II
MAPPED SENSORS AND COEFFICIENTS FOR EACH OBJECTIVE

Mapped Sensor	MRA Coefficient for Objective1	MRA Coefficient for Objective 2
Outdoor Air Drybulb -Sensor	72.18	140.11
Wind Speed -Sensor	102.57	1118.23
Wind Direction-Sensor	1807.64	68.12
Direct Solar Radiation	66.75	312.90
Solar Azimuth Angle	7960.03	72.13
Solar Altitude Angle	417.29	209.34
Zone Mean Air Temperature-Sensor	2001.26	9531.1
Zone Air System Sensible Heating Rate (post processed) Sensor	153.11	107.32
Zone Ideal Load Total Cooling Rate, (post processed)-Sensor	63.06	677.01
Occupancy-Sensor	303.12	462.22

EnergyPlus was used to produce simulated data across the permutations of the scenario's independent variables. In the Forum building, the four actuators resulted in 32 permutations, so the annual simulation was repeated to produce 32 datasets. PCA and MRA were then used to reduce the simulation model's 954 reported variables. The ideal reduction was determined by PCA, and then MRA was used to rank the variables' sensitivity according to the scenario's objectives. This process was modeled as: 1) where F_j denotes either thermal energy consumption or predicted mean vote (PMV) in this case [7]

$$F_j(\vec{\text{Var}}) = \sum_{i=1}^{\text{numvar}} \text{coef}_{ji} \text{Var}_i. \quad (1)$$

In (1), $\vec{\text{Var}}$ denotes the variables generated from the simulation, coef_{ji} denotes the coefficient of variable Var_i for F_j , and numvar is the available number of variables.

The identified variables are then mapped with the existing sensors installed in the target building. Variables which cannot be mapped to sensors can inform the acquisition of additional sensors or can be excluded from subsequent stages of the process. The list of mapped sensors for the Forum building are given in Table II, and were used in the following ANN rule generation.

2) *ANN-Based Learning Process*: ANNs predict the behavior of highly nonlinear systems, such as building energy systems [29], by conducting machine learning over training data. ANNs have been researched in energy management systems for the last two decades [55], yet they continue to perform competitively [56], and as such are still the most widely used type of data-driven model for building energy prediction [57] in research. Hence, this paper also utilizes an ANN-based learning method, where the novelty of the proposed system is the use of this traditional method in a unique way alongside GA, behavioral data mining, fuzzy rules, and ontology technologies, within an end-to-end BEMS. Following experimentation, a traditional multilayer perceptron-based ANN approach was found to perform adequately, although there is room for further investigation into deep architectures and other types of data-driven models, which could be interchanged with the 3-layer MLP used if found to perform better. The proposed ANN design used the ten variables identified previously as inputs, as well as

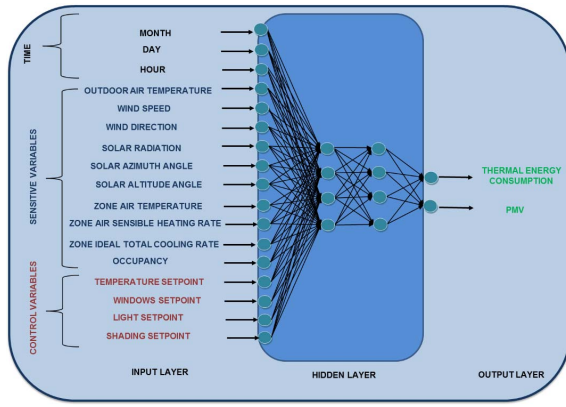

Fig. 6. Proposed ANN topology for the pilot zone.

the four actuator states at the current timestep, and time information. The outputs were then the zone's PMV and energy consumption at the subsequent timestep, as shown in Fig. 6.

For an ANN to be effective, it must be well-trained and use an appropriate topology. To ensure this, the learning algorithm, number of hidden layers (and their number of process elements) and transfer function have to be determined robustly. In this paper, several experiments were designed and conducted to determine the optimum ANN parameters. In the experimental design, an iterative parameter tuning approach is utilized. The initial configuration set is selected as; single hidden layer with five neurons, gradient descent-based learning algorithm, tangent-sigmoid transfer functions in hidden and output layers, 0.0001 error rate, 4000 epochs for number of hidden layer, number of process elements in hidden layer, learning function, error rate and number of epochs, respectively. The next stage is changing one of the parameters while keeping others constant, if the error rate with the selected parameter is better than its constant value will be updated for further parameter selection. The best parameters were found to be: a single hidden layer of 30 neurons, using a Levenberg–Marquardt-based learning function, logarithmic sigmoid and tangent sigmoid-based transfer function in hidden and output layers. Using these parameters, the desired error rate (0.0001) was achieved at 70th epoch.

The ANN was trained with 80% of the dataset and tested on the remaining 20%, within MATLAB. The ANN architecture and training decisions are described further in [7]. This model was then used as the cost function of the GA rule production. The univariate hyperparameter search approach yielded an ANN with sufficient performance within the time and compute limitations of the work, however, further work includes optimizing the ANN design further through grid search or a similar technique.

3) *GA-ANN-Based Optimized Rule Generation*: The rule generation is based on finding optimized solutions for the set of control variable with related environmental variables, desired optimization level (i.e., 5%, 10%, 15%, 20%, 25%, and 30%), and time information. Once an optimum solution is found, this optimum solution and related environmental parameters, date-time info and environmental parameters,

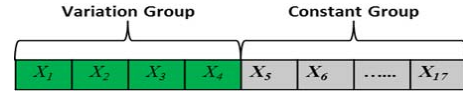

Fig. 7. General formation of the proposed chromosome string.

date-time info, the achieved improvement level, zone ID, and a weight based on the achieved and desired improvement in the target variable.

GA optimization was used with an ANN cost function. GA is a very popular optimization technique for complex problems [7], [30]. The proposed approach uses the actuator states alongside sensor data in the chromosome string, and uses mutation, crossover and fitness evaluation to iteratively improve the rule in a stochastic manner. The general formation of a chromosome string is shown in Fig. 7.

The proposed chromosome string includes two groups: 1) variable and 2) constant features. The variable group includes the control variables (temperature setpoint, window setpoint, blind setpoint, and shading setpoint). The constant group of the string consists of the values of the sensitive variables and time information which are denoted from X_5 to X_{17} for month, day, hour, outdoor temperature, wind speed, wind direction, solar irradiation, solar azimuth angle, solar latitude angle, zone air temperature, zone heating rate, zone ideal total cooling rate, and occupancy, respectively.

Only the control variables (X_1, \dots, X_4) are involved in the mutation and crossover operations of the GA process, and the other string elements are kept constant to determine the optimized value for the control variables. The relationship between cost function variables (inputs and output) is presented in

$$\text{Minimize: } F_{\text{energy consumption}}(X_1, X_2, X_3 \dots X_{17}) \quad (2)$$

$$\text{Subject to constraints: } |F_{\text{PMV}}(X_1, X_2, X_3 \dots X_{17})| < 1 \quad (3)$$

$$16 \leq X_1 \leq 24 \quad (4)$$

$$0 \leq X_2 \leq 1 \quad (5)$$

$$0 \leq X_3 \leq 1 \quad (6)$$

$$0 \leq X_4 \leq 1. \quad (7)$$

$F_{\text{Energy_Consumption}}$ is the energy consumption amount based on the variation of the control variables X_1, X_2, X_3 , and X_4 while keeping other variables (X_5, \dots, X_{17}) constant, and F_{PMV} is constraint named as the PMV function value to keep the thermal comfort under between -1 and 1 .

The genetic algorithm's crossover operation used a multipoint gene exchange within the variation groups of two parents' chromosome strings as shown in Fig. 8. The mutation operation also acted only on the parents' variation groups, where it selected one or more elements according to a probability value as shown in Fig. 8. Both the chromosome and the mutation operations are implemented on the p and r worst regions (solution sets) based on their fitness values, as shown in Fig. 9.

The algorithm used an elite selection approach, where the best $n - p$ solution were kept as original, the crossover

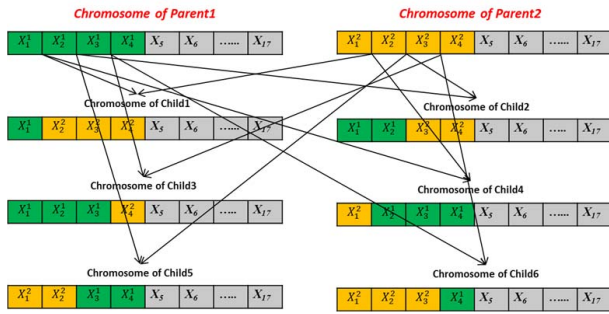

Fig. 8. Crossover operations in the proposed GA.

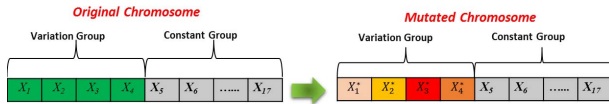

Fig. 9. Mutation operations in the proposed GA.

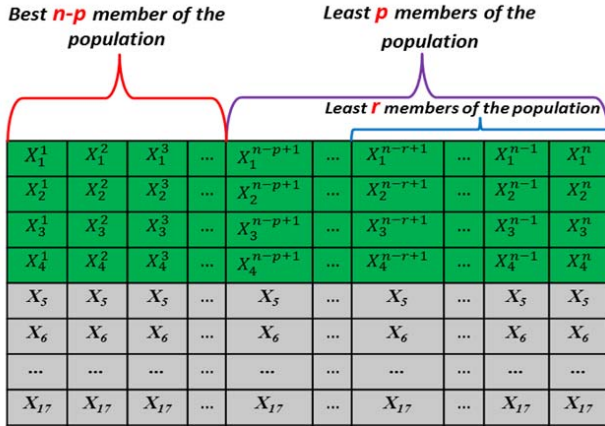

Fig. 10. General formation of the elitism process in the proposed GA.

IF ZoneID=RC0.13ATRMGRNP ^ Weight=1 ^ Type=HeatingReduction ^ ReductionLevel=5% ^ X5=1 ^ X6=1 ^ X7=10 ^ X8>=15.2 ^ X8<=16.8 ^ X9>=17.1 ^ X9<=18.9 X10>=17.8 ^ X10<=19.7 ^ X11>=4.3 ^ X11<=4.7 ^ X12>=254.1 ^ X12<=280.9 ^ X13>=3.6 ^ X13<=3.9 ^ X14>=136.1 ^ X14<=161.5 ^ X15>=57.0 ^ X15<=63.0 ^ X16>=22.7 ^ X16<=25.1 ^ X17>=19.0 ^ X17<=21.0 THEN X1=17.5 ^ X2=0 ^ X3=0 ^ X4=0

Fig. 11. Example of the generated optimized rules.

operation acted on the remaining p chromosome strings, and the mutation probability was α , using the roulette technique. The mutation operation was also implemented on r worst individuals with a β probability rate. Hence, the best solutions are kept in the solution pool as shown in Fig. 10.

The primary stopping condition of the optimization was the target improvement decided by the FM. The FM negotiates an acceptable set of actuations by choosing a target, such as 30% energy reduction, then observing the optimized actuations required, and either accepting these or adjusting the target. An example of the generated rule is shown in Fig. 11, and the overall GA-ANN-based process is shown in Fig. 12.

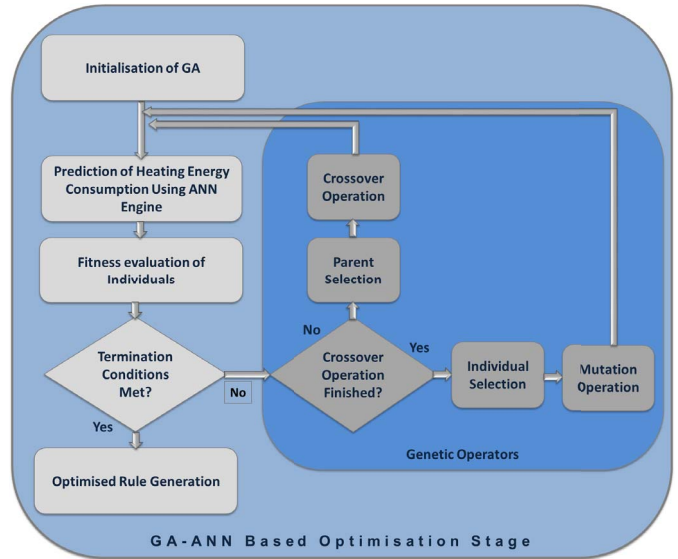

Fig. 12. GA-ANN optimized rule generation process.

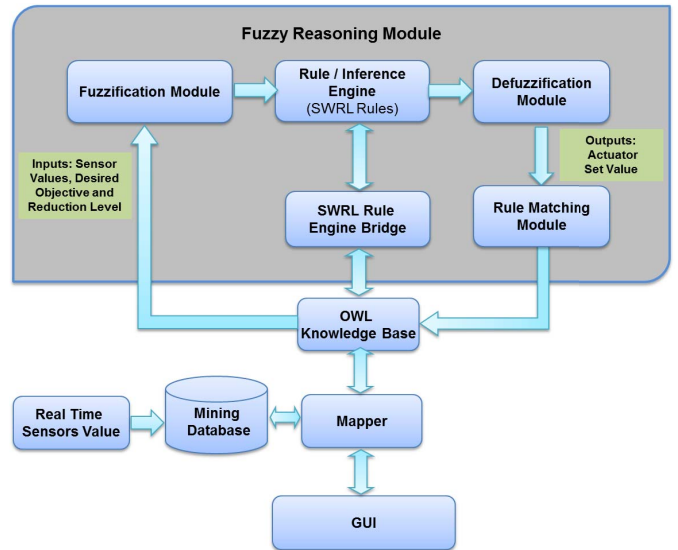

Fig. 13. Fuzzy reasoning module architecture.

C. Fuzzy Reasoner

The rules produced by the GA-ANN process are stored as SWRL rules, but are used by a fuzzy reasoner. Fuzzy logic is inspired by the human, approximation-based, reasoning process [58]. This process rationalizes an appropriate output from inaccurate and incomplete information. The proposed fuzzy reasoner communicates with the GUI through the mapper module, and the knowledge base through the Java expert system shell [59], as shown in Fig. 13. In this paper, a Mamdani fuzzy inference system was utilized: despite this approach's simplicity, it was found to provide adequate performance.

Although the rules are generated automatically through machine learning, the user ultimately decides which rules should be applied. The weights are initially set automatically corresponding to the confidence of the rules, but the user is

TABLE III
RULE VARIABLES FOR THE FORUM BUILDING

Variables in Antecedent Part (IF Antecedents)	Variables in Consequent Part (THEN Consequents)
1- Zone ID, 2- Rule weight, 3- Desired objective type, 4- Reduction level, 5- X5= Month information, 6- X6= Day information 7- X7= Hour information 8- X8= Outdoor temperature, 9- X9= Wind speed , 10- X10= Wind direction, 11- X11= Solar radiation, 12- X12= Solar azimuth angle, 13- X13= Solar altitude angle, 14- X14= Zone mean air temperature, 15- X15= Zone air sensible heating rate, 16- X16= Zone ideal total cooling rate, 17- X17= Occupancy.	1- X1= Temperature set point, 2- X2= Window set point, 3- X3= Shading set point, 4- X4= Light set point.

able to change the weights in accordance with their needs or context, such that the most appropriate rules have higher weights.

The fuzzy reasoner consists of five modules: 1) fuzzification module; 2) SWRL bridge; 3) rule engine; 4) defuzzification module; and 5) rule matching module. This reasoner is used when the FM requests decision support. The first step involves comparing the dynamic sensor data to the antecedent parts of the semantic rules; shown for the Forum building in Table III. The consequent part of the fuzzy rules then defines the optimized actuator states, similar to the approach of Wang and Mendel [64]. However, in this paper, the antecedents consist of a wide variety of range-based formations, instead of predefined membership functions.

As well as accuracy, interpretability is an important and often conflicting performance metric in fuzzy rule-based systems. Casillas *et al.* [60] defined interpretability in this context as the capacity to express the qualities of the real system as subjective properties based on experts' assessments. Another comprehensive survey on the topic is presented by Lughofer [61], who suggests that one of the prerequisites for interpretability is complexity reduction, which is part of the distinguishability and simplicity of the fuzzy rule partitioning process. This is supported by the similar sentiment of Gacto *et al.* [62], who presented a detailed review about interpretability and complexity. Hence, to promote interpretability, the fuzzy reasoner of the proposed system uses a small number of relatively simple triangular membership functions with predefined ranges, as illustrated in Fig. 14. Also, prior work suggests that this approach promotes greater performance and is computationally inexpensive [63]. This was valuable given the large number of SWRL rules used in the proposed system.

These rules are then converted into fuzzy rules with a constant number of membership functions. The inference engine then implements the membership conversion given in (2).

The fuzzy reasoner incorporates fuzzy rules which are made by mapping between the crisp variables of the theoretical rules and fuzzified variables. This fuzzification process uses fuzzy membership function labels and the related membership

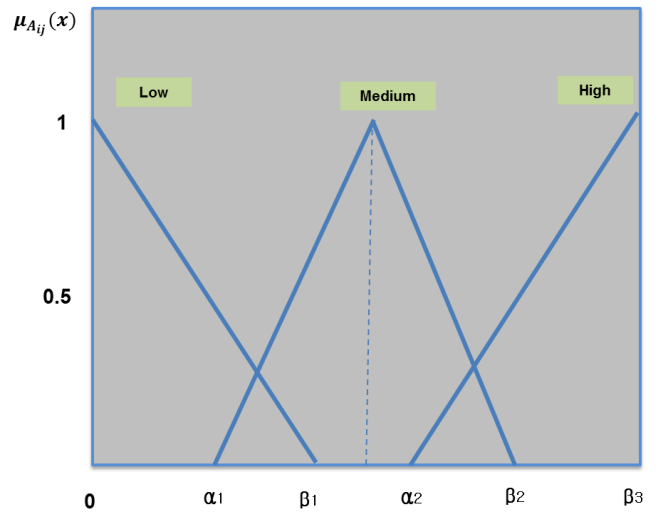

Fig. 14. Fuzzy membership function example.

degrees for each corresponding crisp variable. The optimized rule antecedent part consists of the rule weight, desired optimization level, optimization objective level, outdoor temperature, wind speed, wind direction, solar radiation, solar azimuth and altitude angles, indoor temperature, zone sensible heating and total cooling rates, and occupancy levels, respectively. The consequent part consists of the control variable values. The fuzzification process converts the variables in both the antecedent and consequent parts of the crisp rules. The rule conversion is based on Wang Mendel approach [62] which consists of: 1) identifying the membership degrees in every fuzzy partition of inputs and output variables and 2) associating the existing crisp rules with a fuzzy rule which has a linguistic label with maximum degree. Hence, the rules are presented in the form of “IF in_1 is $label_{in_1}$ and in_2 is $label_{in_2}$ and \dots and in_n is $label_{in_n}$, THEN out_1 is $label_{out_1}$,” where $label_{in_i}$ is the best covered linguistic label in each input subspace and $label_{out_1}$ is the best covered output label. The membership degree of the rule in each subspace is $\mu_{label_{in_i}}$ and $\mu_{label_{out_1}}$, respectively. To avoid conflicting rules, we have utilized importance degree, where if there are multiple rules which have the same antecedent and consequent labels then the one with the greatest importance degree will remain in the rule base. The importance degree for each rule is computed based on following (8) to evaluate the interpretability:

$$ID(\text{Rule}) = \mu_{label_{in_1}} \mu_{label_{in_2}} \cdots \mu_{label_{in_n}} \mu_{label_{out_1}}. \quad (8)$$

Nine hundreden fifty eight rules were generated for each objective, resulting in 3882 rules in total. The inference engine then implements the membership-based conversion given in (9), where μ_{V_k} is the membership value of the output variable. An example of converted fuzzy rule is presented in Fig. 15. The inference engines design is based on the experts' experiences

$$\mu_{V_k} = \min(\max(\mu_{A_{11}} \cdots \mu_{A_{m1}}), \dots, \max(\mu_{A_{12}} \cdots \mu_{A_{m2}})). \quad (9)$$

```

IF Weight=HIGHEST ^ EfficiencyTarget=MEDIUM ^ HeatingReduction=MEDIUM ^
OutdoorTemperature=COLD ^ WindSpeed=FAST ^ WindDirection=LOW ^ SolarRadiation=LOW ^
AzimuthAngle=LOW ^ SolarAltitudeAngle=LOW ^ ZoneAirTemperature=MEDIUM ^
ZoneAirSensibleHeatingRate=MEDIUM ^ ZoneIdealTotalCoolingRate=LOWEST ^ occupancy=HIGH
THEN TemperatureSetPoint=MEDIUM

```

Fig. 15. Example fuzzy rules presented in inference engine.

The defuzzification process then determines the selected output values for any given input set. This operation uses a rule weighting method, which increases the accuracy of the fuzzy system [65]. The weight given to each rule before the fuzzification is also included as a coefficient in the reasoning process, as shown in

$$V_{\text{crisp}} = \frac{\sum w_i \mu_V(Y) Y}{\sum w_i \mu_V(Y)} \quad (10)$$

The rule weight is determined by the closeness of the expected target value to its desired value, evaluated by simulation during the rule generation process. The weights are calculated according to (11), where w_i , y_i , and \hat{y}_i are the i th rule's percentage weight, best solution found, and expected target optimization level, respectively

$$w_i = 100 \left| \frac{y_i - \hat{y}_i}{w_i} \right| \quad (11)$$

To summarize, SWRL rules are generated through an optimized ANN-based approach (ANN-genetic algorithm), for different reduction levels, which is the basis of the theoretical rule generation process, the generated rules are then converted into fuzzy rules to create the rule base of the fuzzy inference system by inclusion of the linguistic transformations. Once a user desired level of reduction for a desired objective is received then the fuzzy inference engine is to utilize these inputs for its inference engine and to determine the most convenient outcomes in the existing post-processed SWRL rules. After determining the consequent, the rule engine searches for rules with the same actuator states and sorts them according to their weights stored in the knowledge base. The highest weighted one is selected as a response for the users.

VI. SMART GUI

This section describes the implementation and features of the front-end tool and how it accesses the different data sources to enable monitoring and visualization of the relevant static and dynamic data, and the display of suggestions to the FM. The interface has been evaluated to determine its level of usability, the resulting findings determined that over five demo objects, one of which forms the core of the evaluation presented here, the FMs were supported in the task of identifying and applying suggestions [66]. The BEMS interface was implemented using modern Web languages and the bootstrap framework [6]. The interface contains three main windows; Fig. 16 shows the WebGL view of the building's zones and Fig. 17 shows the energy monitoring and actuation suggestion window. The interface also has a menu "choose building," so that the FM can select different buildings, if they are responsible for more than one. First, the ability to view the static properties and the historic and current energy KPIs of each building and zone under an FM's remit is discussed. Second,

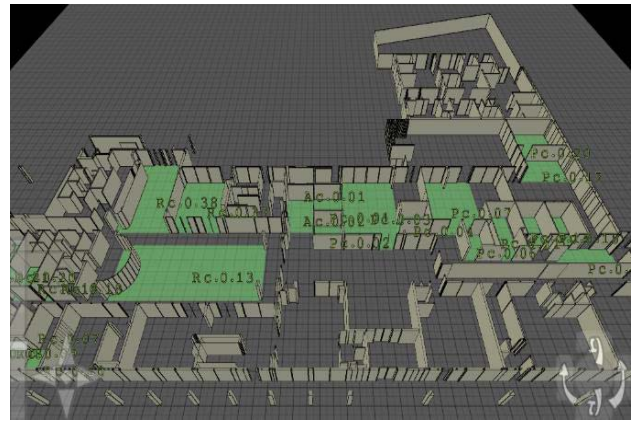

Fig. 16. WebGL view of the building's zones.

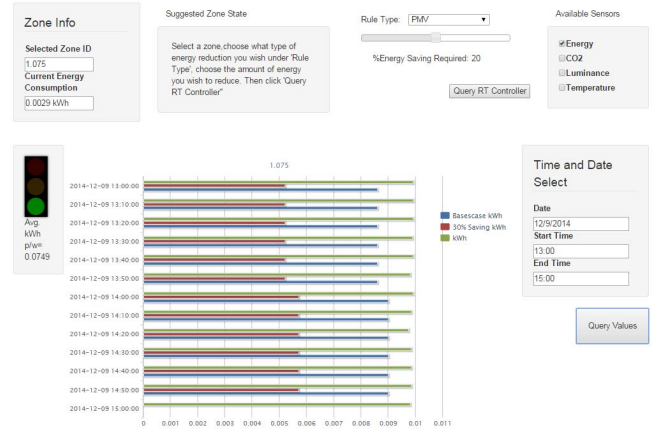

Fig. 17. Zone energy monitoring interface.

the role of the GUI in presenting the knowledge from the solutions' various analytics components, in the form of suggested actions, is presented.

A. Building Zone View and Performance Monitoring

A 3-D visualization of the building's thermal zones was seen as a key requirement of an engaging tool, so this was enabled by converting 2-D CAD plans into semantic models in the knowledge base. As well as showing an extruded floor plan of the building, each zone is described in the knowledge base by its geometric properties, function (kitchen, atrium, etc.), ID, and its connected sensors, and these are all displayed after clicking the zone, which triggers a query of the knowledge base.

After choosing a zone and a sensor type (or multiple types), the energy monitoring interface shown in Fig. 16 allows the FM to view the current and historic performance of the zone. This is achieved through a histogram of sensed data values and a traffic light graphic which indicates the acceptability of the current performance, relative to its mean value. The historical sensor data is retrieved from the SQL database using a combination of AJAX and PHP server-side scripting. SQL was chosen due to the speed at which it can handle queries for large amounts of historical data.

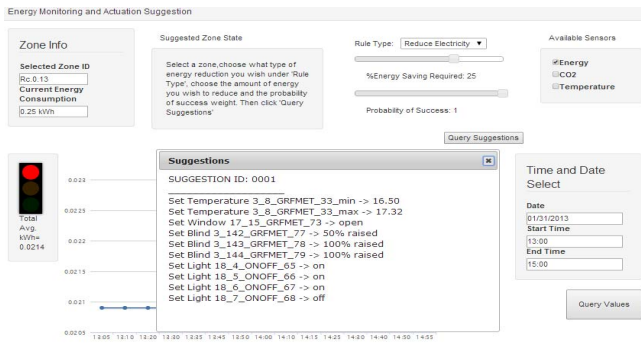

Fig. 18. Actuation suggestions query window.

The suggestions are tailored to a particular zone, which is generally a room. The tool also shows 3-D coordinates for sensors, based on industry foundation class data, or manual data entry. Incorporating IFC Cartesian locations represents ongoing work. Also, the color of each sensor’s icon represents its current state.

B. Optimized Suggestion and Negotiation Interface

To deliver the knowledge produced by the solution’s analytics, and hence support the FM in reducing the energy consumption of the building, the interface displays suggested actions as part of a negotiation interface based on the data mining, theoretical rules, and their fuzzification. Fig. 18 shows how the FM configures these criteria using drop down menus and slider bars, generated by jQuery selectors. Once the FM has selected a zone, chosen a goal type (e.g., reduce electricity consumption) and moved the slider to the target energy saving (e.g., 20%) they press the “query suggestions” button. This uses AJAX and PHP to query and return suggestions based on the rules produced by the back-end analytics and displays a number of recommended actions, such as adjusting the blinds or heating temperature set point.

Critically, the FM’s expert knowledge is then utilized to determine if the suggested actions are appropriate, as the simulated implications on the building are then displayed in the energy monitoring histograms, and the FM chooses whether or not to act on the suggestions. If they deem the savings to have negative implications on comfort, or otherwise, they can adjust the query criteria and view more suitable suggested actions. This means of control was a requirement of the solution, as FMs during the aforementioned usability evaluations indicated that they wished to have final say on whether to enact changes.

VII. RESULTS

To evaluate the performance of the developed solution, the system’s intelligence was tested in the EnergyPlus simulation environment and the full system was deployed in a real pilot building, so as to validate the entire system, including the semantic middleware and GUI components. The pilot building was a public residential care home in The Netherlands (the Forum), and the decision support capabilities of the system were tested for the building’s 3-storey atrium zone;

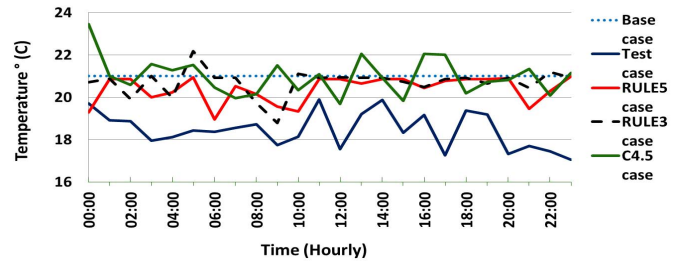

Fig. 19. One-day simulation temperature setpoint profiles.

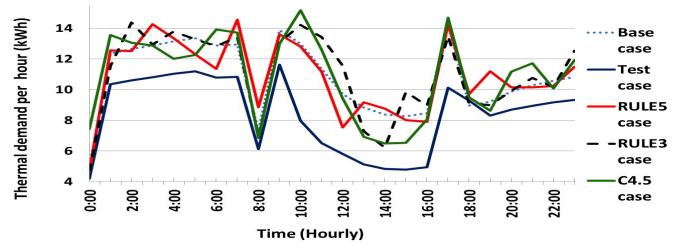

Fig. 20. One-day simulation energy consumption profiles.

the main energy consuming space of the building. As the Forum building is primarily an elderly care home, maintaining thermal comfort was critical whilst attempting to reduce the building’s energy consumption by using the suggested actions of the system.

Initially, the proposed solution was tested by simulating the zone’s energy consumption over a day and then repeating the simulation with the optimized energy saving rules, applied at the start of each timestep. This reduced the energy consumption from 258 to 201 kWh, whilst maintaining an absolute PMV of less than 1, which was deemed an acceptable level of occupant comfort. In contrast, the well-known rule-based systems RULE5, RULE3, and C4.5 only achieved energy consumptions of 258 kWh, 259 kWh, and 259 kWh, respectively, with the absolute PMV values increasing to 1.7, which represents greater discomfort. The generated set points and resulting energy consumption profiles from these experiments are shown in Figs. 19 and 20.

Following preliminary success, the simulation was extended to a two-month period. Using the proposed method the energy consumption was reduced from 14 600 to 11 400 kWh during the months of October and November, whereas RULE5, RULE3, and C4.5 achieved 13 500 kWh, 13 900 kWh, and 15 400 kWh, respectively, as shown in Fig. 21. Again, the proposed approach maintained an absolute PMV of less than 1.

The full retrofit BEMS solution was then deployed in the pilot building, initially for a single day and subsequently for an extended period from October 1, 2014 to January 20, 2015. In each of these tests the FM utilized the system’s decision support to receive suggested actions for energy saving, and after negotiating the severity of these, actioned them through local control systems. Based on the single day experiment, the daily energy consumption was reduced from 77 to 58 kWh as illustrated in Fig. 22. Over the two month period, the total energy consumption reduced from 7500 to 5600 kWh, when adjusted for degree day temperature correction, as shown in

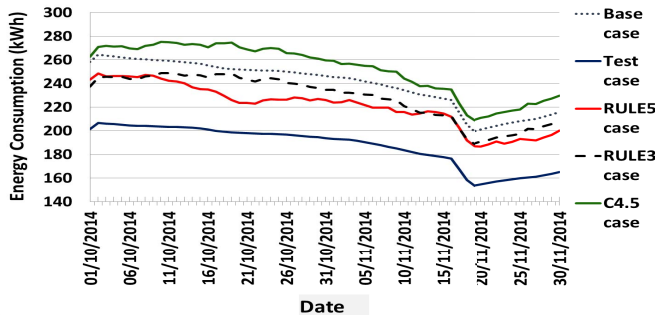

Fig. 21. Two-month simulation average energy consumption per day.

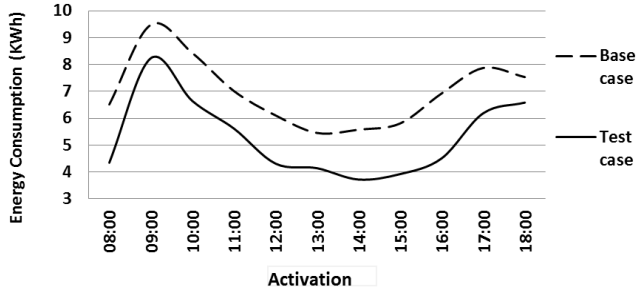

Fig. 22. One-day real pilot site energy consumption.

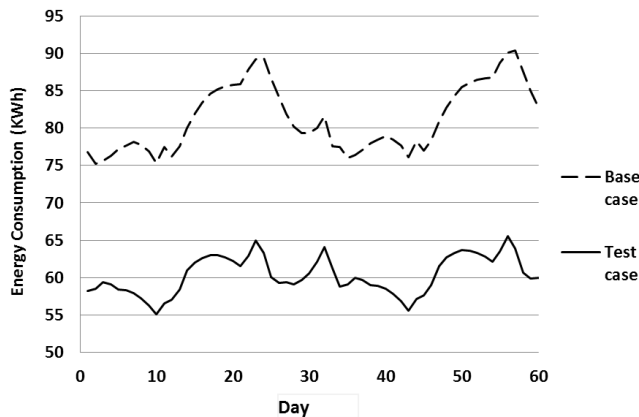

Fig. 23. Two-month real pilot site energy consumption.

Fig. 23. Finally, the FM was satisfied with the thermal comfort achieved and no negative feedback was received from the occupants.

VIII. DISCUSSION AND CONCLUSION

This paper has presented a retrofit BEMS capable of delivering energy savings through analytics across existing data sources and actuators in a building, by using semantic middleware to integrate heterogeneous devices within a cloud-based, service-oriented architecture. As well as the novelty of the semantic approach, the solution represents a step change by encouraging the use of AI by FMs, by respecting the FM's role in the decision process and using an engaging GUI, and the solution has been successfully deployed in a public building in The Netherlands.

In this paper, the state of the art and previous research was discussed within each of the conceptual layers of a retrofit BEMS. A novel BEMS was then introduced and the components and methodology of each of its layers were discussed in turn. First, the semantic middleware layer was introduced as a key novelty, and its benefits of interoperating a building's devices and systems in an extensible, replicable and affordable manner was explained. The methodology of instantiating a domain ontology aligned with international standards was presented through the use of OntoCAD to populate an extended version of the IFC data model. Second, the solution's intelligence was explained as a combination of intelligent rule generation techniques and a fuzzy reasoner. The combined use of rules generated through data mining and simulation-based optimization through SWRL ontology integration was shown. Finally, the GUI of the solution was explored; its interactions with the back-end to present zone-based performance monitoring and optimized rule suggestions were explained. Also, the client-side software decisions of WebGL and HTML5 were discussed as a means to enable cross platform deployment without requiring additional user downloads, whilst still providing a 3-D interface and many developer benefits toward further maturing the solution. Through a simple traffic light graphic, FMs can determine the zones requiring attention, and the pop ups alert the FM when a new energy saving suggestion is made. This type of feature would be ideal for mobile integration, so that FMs can be alerted in the field.

The solution was tested within both simulated and real buildings, with encouraging results in both cases. Both cases showed significant energy savings over both a single day and a period of several winter months, with the real building displaying circa 25% energy savings on average. Whilst these results are highly positive and serve as a proof of concept, further work is now required to demonstrate the solution's replicability across other buildings. Other features which are of interest for development include the use of a wizard to help the FM with tasks, and providing multilingual support to allow deployment across countries; as driving FM engagement with the tool through an attractive and intuitive interface is a key contribution of the work.

Whilst the individual components used in the proposed system delivered sufficient performance, key ongoing work includes further optimization of each. For example, the ANN model implemented could be interchanged with a more advanced deep learning model, and its hyperparameters could be further optimized via a dense grid search or similar.

Given the successful deployment of the solution and the key novelties identified, this paper demonstrates the potential of a cloud-based approach to a retrofit BEMS solution by using semantic middleware as a system integration component alongside a human-computer negotiation process, advanced AI and an engaging user interface. The BEMS presented can therefore act as a reference point for similar solutions in terms of the energy saving potential, upfront investment reduction through system integration, and logistics and liability issue mitigation regarding AI control of building systems.

ACKNOWLEDGMENT

The authors would like to thank the indirect contributions of the research partners, especially CETMA for their contribution toward the fuzzy aspects of the KnoholEM project and Kiril Tonev for his role in the software implementation of the interoperability layer.

REFERENCES

- [1] L. Pérez-Lombard, J. Ortiz, and C. Pout, "A review on buildings energy consumption information," *Energy Build.*, vol. 40, no. 3, pp. 394–398, Mar. 2008.
- [2] A. DePaola, M. Ortolani, G. L. Re, G. Anastasi, and S. K. Das, "Intelligent management systems for energy efficiency in buildings: A survey," *ACM Comput. Surveys*, vol. 47, no. 1, pp. 1–38, Jul. 2014.
- [3] P. Hoes, J. L. M. Hensen, M. G. L. C. Loomans, B. de Vries, and D. Bourgeois, "User behavior in whole building simulation," *Energy Build.*, vol. 41, no. 3, pp. 295–302, Mar. 2009.
- [4] Y. Agarwal *et al.*, "Occupancy-driven energy management for smart building automation," in *Proc. 2nd ACM Workshop Embedded Sens. Syst. Energy Efficiency Build.*, Zürich, Switzerland, Nov. 2010, pp. 1–6.
- [5] O. T. Masoso and L. J. Grobler, "The dark side of occupants' behaviour on building energy use," *Energy Build.*, vol. 42, no. 2, pp. 173–177, Feb. 2010.
- [6] M. Dibley, H. Li, Y. Rezgui, and J. Miles, "Software agent reasoning supporting non-intrusive building space usage monitoring," *Comput. Ind.*, vol. 64, no. 6, pp. 678–693, Aug. 2013.
- [7] B. Yuce and Y. Rezgui, "An ANN-GA semantic rule-based system to reduce the gap between predicted and actual energy consumption in buildings," *IEEE Trans. Autom. Sci. Eng.*, vol. 14, no. 3, pp. 1351–1363, Jul. 2017.
- [8] P. H. Shaikh, N. B. M. Nor, P. Nallagownden, I. Elamvazuthi, and T. Ibrahim, "A review on optimized control systems for building energy and comfort management of smart sustainable buildings," *Renew. Sustain. Energy Rev.*, vol. 34, pp. 409–429, Jun. 2014.
- [9] M. Dibley, H. Li, Y. Rezgui, and J. Miles, "An ontology framework for intelligent sensor-based building monitoring," *Autom. Construct.*, vol. 28, pp. 1–14, Dec. 2012.
- [10] S. Howell, Y. Rezgui, and B. Yuce, "Knowledge-based holistic energy management of public buildings," in *Proc. Int. Conf. Comput. Civil Build. Eng.*, 2014, pp. 1667–1674, doi: [10.1061/97870784413616.207](https://doi.org/10.1061/97870784413616.207).
- [11] A. H. Kazmi, M. J. O'grady, D. T. Delaney, A. G. Ruzzelli, and G. M. P. O'hare, "A review of wireless-sensor-network-enabled building energy management systems," *ACM Trans. Sensor Netw.*, vol. 10, no. 4, pp. 1–43, Jun. 2014.
- [12] R. V. P. Yerra and P. Rajalakshmi, "Context aware building energy management system with heterogeneous wireless network architecture," in *Proc. Wireless Mobile Netw. Conf. (WMNC)*, Dubai, UAE, Apr. 2013, pp. 1–8.
- [13] K. Park *et al.*, "Building energy management system based on smart grid," in *Proc. IEEE 33rd Int. Telecommun. Energy Conf. (INTELEC)*, Oct. 2011, pp. 1–4.
- [14] IEEE Standards Committee, "Communication technology interoperability," in *IEEE Guide for Smart Grid Interoperability of Energy Technology and Information Technology Operation With the Electric Power System (EPS), End-Use Applications and Loads*, New York, NY, USA: Inst. Elect. Electron. Eng., Sep. 2011, pp. 42–63.
- [15] BSI British Standards, *Smart City Concept Model—Guide to Establishing a Model for Data Interoperability*. London, U.K.: BSI Stand., Oct. 2014.
- [16] W. Shang, Q. Ding, A. Marianantoni, J. Burke, and L. Zhang, "Securing building management systems using named data networking," *IEEE Netw.*, vol. 28, no. 3, pp. 50–56, May/June. 2014.
- [17] T. E. El-Diraby and J. Zhang, "A semantic framework to support corporate memory management in building construction," *Autom. Construct.*, vol. 15, no. 4, pp. 504–521, Jul. 2006.
- [18] H. Wicaksono, K. Aleksandrov, and S. Rogalski, "Knowledge-based intelligent energy management using building automation system," in *Automation*. London, U.K.: InTechOpen, 2012. [Online]. Available: <https://www.intechopen.com/books/automation/an-intelligent-system-for-improving-energy-efficiency-in-building-using-ontology-and-building-automa>
- [19] W3C. *Semantic Web*. Accessed: Dec. 14, 2015. [Online]. Available: <http://www.w3.org/standards/semanticweb/>
- [20] A. Pal, A. Mukherjee, and B. Purushothaman, "Model-driven development for Internet of Things: Towards easing the concerns of application developer," in *Internet of Things. User-Centric IoT*, vol. 150, R. Giuffreda *et al.*, Eds. Cham, Switzerland: Springer, 2015, pp. 339–346.
- [21] W3C. (2015). *Linked Data Platform 1.0*. Accessed: Dec. 30, 2015. [Online]. Available: <http://www.w3.org/TR/2015/REC-ldp-20150226/>
- [22] "Industrial strategy: Government and industry in partnership," HM Govt., London, U.K., Govt. Rep. BIS/13/955, 2012.
- [23] H. Wicaksono, P. Dobрева, P. Häfner, and S. Rogalski, "Methodology to develop ontological building information model for energy management system in building operational phase," in *Knowledge Discovery, Knowledge Engineering and Knowledge Management Communications in Computer and Information Science*, vol. 454. Heidelberg, Germany: Springer, Sep. 2015, pp. 168–181.
- [24] M. Kadolsky *et al.*, *ISES Deliverable D3. 1: Ontology Specification*, ISES, Brussels, Belgium, Jan. 2014.
- [25] J. Ploennigs, H. Dibrowski, A. Roder, K. Kabitzsch, and B. Hensel, *HESMOS Deliverable D4.1: Ontology Specification for Model-Based ICT System Integration*, HESMOS, Brussels, Belgium, Nov. 2011.
- [26] R. Gulbinas, A. Khosrowpour, and J. Taylor, "Segmentation and classification of commercial building occupants by energy-use efficiency and predictability," *IEEE Trans. Smart Grid*, vol. 6, no. 3, pp. 1414–1424, May 2015.
- [27] J. S. Byun and S. Park, "Development of a self-adapting intelligent system for building energy saving and context-aware smart services," *IEEE Trans. Consum. Electron.*, vol. 57, no. 1, pp. 90–98, Feb. 2011.
- [28] U. Rutishauser, J. Joller, and R. Douglas, "Control and learning of ambience by an intelligent building," *IEEE Trans. Syst., Man, Cybern. A, Syst., Humans*, vol. 35, no. 1, pp. 121–132, Jan. 2005.
- [29] B. Yuce *et al.*, "Utilizing artificial neural network to predict energy consumption and thermal comfort level: An indoor swimming pool case study," *Energy Build.*, vol. 80, pp. 45–56, Sep. 2014.
- [30] C. Yang *et al.*, "High throughput computing based distributed genetic algorithm for building energy consumption optimization," *Energy Build.*, vol. 76, pp. 92–101, Jun. 2014.
- [31] H. Grzybek, S. Xu, S. Gulliver, and V. Fillingham "Considering the feasibility of semantic model design in the built-environment," *Buildings*, vol. 4, no. 4, pp. 849–879, Nov. 2014.
- [32] K. K. Rohitha, G. K. Hewawasam, K. Premaratne, and M. L. Shyu, "Rule mining and classification in a situation assessment application: A belief-theoretic approach for handling data imperfections," *IEEE Trans. Syst., Man, Cybern. B, Cybern.*, vol. 37, no. 6, pp. 1446–1459, Dec. 2007.
- [33] L. Cao, H. Zhang, Y. Zhao, D. Luo, and C. Zhang, "Combined mining: Discovering informative knowledge in complex data," *IEEE Trans. Syst., Man, Cybern. B, Cybern.*, vol. 41, no. 3, pp. 699–712, Jun. 2011.
- [34] J. Casillas, O. Cordon, and F. Herrera, "COR: A methodology to improve ad hoc data-driven linguistic rule learning methods by inducing cooperation among rules," *IEEE Trans. Syst., Man, Cybern. B, Cybern.*, vol. 32, no. 4, pp. 526–537, Aug. 2002.
- [35] L. M. Fu, "Rule generation from neural networks," *IEEE Trans. Syst., Man, Cybern., Syst.*, vol. 24, no. 8, pp. 1114–1124, Aug. 1994.
- [36] T.-P. Wu and S.-M. Chen, "A new method for constructing membership functions and fuzzy rules from training examples," *IEEE Trans. Syst., Man, Cybern. B, Cybern.*, vol. 29, no. 1, pp. 25–40, Feb. 1999.
- [37] P. Maji and P. Garai, "Fuzzy-rough simultaneous attribute selection and feature extraction algorithm," *IEEE Trans. Cybern.*, vol. 43, no. 4, pp. 1166–1177, Aug. 2013.
- [38] T. Pal and N. R. Pal, "SOGARG: A self-organized genetic algorithm-based rule generation scheme for fuzzy controllers," *IEEE Trans. Evol. Comput.*, vol. 7, no. 4, pp. 397–415, Aug. 2003.
- [39] C.-F. Juang and P.-H. Chang, "Designing fuzzy-rule-based systems using continuous ant-colony optimization," *IEEE Trans. Fuzzy Syst.*, vol. 18, no. 1, pp. 138–149, Feb. 2010.
- [40] S. Mitra and Y. Hayashi, "Neuro-fuzzy rule generation: Survey in soft computing framework," *IEEE Trans. Neural Netw.*, vol. 11, no. 3, pp. 748–768, May 2000.
- [41] E. Lughofer, *Evolving Fuzzy Systems—Methodologies, Advanced Concepts and Applications*. Heidelberg, Germany: Springer, 2011.

- [42] E. Lughofer, "Evolving fuzzy systems—Fundamentals, reliability, interpretability and useability," in *Handbook of Computational Intelligence*, P. P. Angelov, Ed. New York, NY, USA: World Sci., 2016, pp. 67–135.
- [43] J. R. Quinlan, *C4.5: Programs for Machine Learning*. San Francisco, CA, USA: Morgan Kaufmann, 1993.
- [44] W. Heidl, S. Thumfart, E. Lughofer, C. Eitzinger, and E. P. Klement, "Machine learning based analysis of gender differences in visual inspection decision making," *Inf. Sci.*, vol. 224, pp. 62–76, Mar. 2013.
- [45] E. Lughofer *et al.*, "Explaining classifier decisions linguistically for stimulating and improving operators labeling behavior," *Inf. Sci.*, vol. 420, pp. 16–36, Dec. 2017.
- [46] R. Senge and E. Hüllermeier, "Top-down induction of fuzzy pattern trees," *IEEE Trans. Fuzzy Syst.*, vol. 19, no. 2, pp. 241–252, Apr. 2011.
- [47] J. Fürnkranz, "Round robin classification," *J. Mach. Learn. Res.*, vol. 2, pp. 721–747, Mar. 2002.
- [48] B. Soua, A. Borgi, and M. Tagina, "Attributes regrouping in fuzzy rule based classification systems," in *Proc. IEEE Conf. Signals Circuits Syst. (SCS)*, Nov. 2009, pp. 1–6.
- [49] Mona Visa. *Mona Visa Dashboard*. Accessed: Dec. 30, 2015. [Online]. Available: <http://www.monavisa.info/home/dashboard.jsp>
- [50] G. Anzaldi *et al.*, "KnoHolEM: Knowledge-based energy management for public building through holistic information modeling and 3-D visualization," in *Proc. 2nd INTERA Conf. Int. Technol. Robot. Appl.*, 2014, pp. 47–58.
- [51] M. Dankers, F. van Geel, and N. M. Segers, "A Web-platform for linking IFC to external information during the entire lifecycle of a building," *Procedia Environ. Sci.*, vol. 22, pp. 138–147, Dec. 2014.
- [52] K. Krahtov, S. Rogalski, D. Wacker, D. Gutu, and J. Ovtcharova, "A generic framework for life-cycle-management of heterogenic building automation system," in *Proc. Flexible Autom. Intell. Manuf. Conf.*, Jul. 2009, pp. 461–468.
- [53] P. Häfner, V. Häfner, H. Wicaksono, and J. Ovtcharova, "Semi-automated ontology population from building construction drawing," in *Proc. Knowl. Eng. Ontol. Develop. Conf.*, Sep. 2013, pp. 379–386.
- [54] K. McGlenn, K. Jones, A. Cochero, A. Gerdelan, and D. Lewis, "Usability evaluation of an activity modelling tool for improving accuracy of predictive energy simulations," in *Proc. IBPSA Build. Simulat. Conf.*, Dec. 2015, pp. 1798–1805.
- [55] S. A. Kalogirou, "Applications of artificial neural-networks for energy system," *Appl. Energy*, vol. 67, nos. 1–2, pp. 17–35, Sep. 2000.
- [56] M. W. Ahmad, M. Mourshed, and Y. Rezgui, "Trees vs neurons: Comparison between random forest and ANN for high-resolution prediction of building energy consumption," *Energy Build.*, vol. 147, no. 15, pp. 77–89, 2017.
- [57] K. Amasyali and N. M. El-Gohary, "A review of data-driven building energy consumption prediction studies," *Renew. Sustain. Energy Rev.*, vol. 81, pp. 1192–1205, Jan. 2018.
- [58] L. A. Zadeh, "A theory of approximate reasoning," in *Machine Intelligence*, vol. 9, J. E. Hayes, D. Mitchie, and L. I. Mikulich, Eds. New York, NY, USA: Wiley, 1979, pp. 149–194.
- [59] R. Orchard, "Fuzzy reasoning in JESS: The FuzzyJ toolkit and FuzzyJESS," in *Proc. 3rd Int. Conf. Enterprise Inf. (ICEIS)*, Jul. 2001, pp. 533–542.
- [60] J. Casillas, O. Cordon, F. Herrera, and L. Magdalena, *Interpretability Issues in Fuzzy Modeling*. Heidelberg, Germany: Springer-Verlag, 2003.
- [61] E. Lughofer, "On-line assurance of interpretability criteria in evolving fuzzy systems—Achievements, new concepts and open issues," *Inf. Sci.*, vol. 251, pp. 22–46, Dec. 2013.
- [62] M. J. Gacto, R. Alcalá, and F. Herrera, "Interpretability of Linguistic fuzzy rule-based systems: An overview of interpretability measures," *Inf. Sci.*, vol. 181, no. 20, pp. 4340–4360, Oct. 2011.
- [63] W. Pedrycz, "Why triangular membership functions?" *Fuzzy Sets Syst.*, vol. 64, no. 1, pp. 21–30, 1994.
- [64] L.-X. Wang and J. M. Mendel, "Generating fuzzy rules by learning from examples," *IEEE Trans. Syst., Man, Cybern.*, vol. 22, no. 6, pp. 1414–1427, Nov./Dec. 1992.
- [65] S.-M. Chen and W.-C. Hsin, "Weighted fuzzy interpolative reasoning based on the slopes of fuzzy sets and particle swarm optimization techniques," *IEEE Trans. Cybern.*, vol. 45, no. 7, pp. 1250–1261, Jul. 2015.
- [66] K. McGlenn, B. Yuce, H. Wicaksono, S. Howell, and Y. Rezgui, "Usability evaluation of a Web-based tool for supporting holistic building energy management," *Autom. Construct.*, vol. 84, pp. 154–165, Dec. 2017, doi: [10.1016/j.autcon.2017.08.033](https://doi.org/10.1016/j.autcon.2017.08.033).



Shaun K. Howell received the Ph.D. degree in applied AI and semantic Web systems from Cardiff University, Cardiff, U.K., in 2017.

He has researched on nine research projects at national and international levels and produced over 30 publications. He continues his research into applied AI with Vivacity Labs, London, U.K., as a Senior Machine Learning Researcher. His current research interests include deep neural networks, multiagent systems, and semantic Web technologies.



Hendro Wicaksono received the Dr.-Ing. degree from the Karlsruhe Institute of Technology, Karlsruhe, Germany, in 2016.

He is currently a Professor of industrial engineering with the Jacobs University Bremen, Bremen, Germany. He was a Researcher with the Institute of Information Management in Engineering, Karlsruhe Institute of Technology. He is also a Visiting Professor with the Faculty of Economics and Business, Airlangga University, Surabaya, Indonesia. He has been researching and managing teens of international research projects in energy-management systems in buildings, production, and cities using semantic technologies and data mining. He has published over 40 papers (two nominations for Best Papers).



Baris Yuce (M'15) received the Ph.D. degree from Cardiff University, Cardiff, U.K., in 2012.

He was with the School of Engineering, Cardiff University from 2013 to 2017. He is a Lecturer with the University of Exeter, Exeter, U.K. His current research interests include intelligent systems, such as optimization algorithms, ANN, fuzzy logic, multiagent systems and their applications on smart buildings, energy systems, robotics, water management systems, scheduling, and supply chain management. He has published over 35 papers

in the above fields.

Dr. Yuce is a member of the IEEE Robotics and Automation Society and IEEE Power and Energy Society.



Kris McGlenn received the Ph.D. degree from Trinity College Dublin, Dublin, Ireland, in 2013.

He is a Research Fellow with Adapt Centre, Trinity College Dublin. He has been conducting research for over ten years in knowledge engineering, building automation, and ubiquitous computing. His research has been in the exploration of BIM and Linked Data Technologies, to address issues for IT related to interoperability and integration of building and building related data models.

Dr. McGlenn is also the Chair of the W3C Linked Building 1286 Data Community Group.



Yacine Rezgui received the M.Eng. and Ph.D. degrees from ENPC, Marne-la-Vallée, France.

He is a Professor of building systems and informatics with Cardiff University, Cardiff, U.K., and the Founding Director of the BRE Centre in Sustainable Engineering. He conducts research in informatics, including ontology engineering and artificial intelligence applied to the built environment. He has over 200 refereed publications in the above areas and has successfully completed over 40 research projects at a national and international

(European Framework Programs) levels.