

# Laboratory Education of Modern Power Systems Using PHIL Simulation

Panos C. Kotsampopoulos, *Student Member, IEEE*, Vasilis A. Kleftakis, and Nikos D. Hatziargyriou, *Fellow, IEEE*

**Abstract**—Power hardware-in-the-loop (PHIL) simulation allows the connection of a physical power component (e.g., photo-voltaic inverter) to a real-time simulated network. In this paper, PHIL simulation is used for laboratory education in a systematic way for the first time. Four important topics for the understanding of power system operation are selected and laboratory exercises are designed, respectively. The topics focus on the effects of increased integration of distributed generation (DG), namely, power sharing between synchronous generators and DG, voltage control with on load tap changer and DG, short circuits with inverter-based DG, and microgrid operation. The exercises start from the operation of the traditional power system and gradually incorporate DG-related topics that show both benefits and challenges. A hands-on approach is supported by the appropriate lab configuration consisting of two independent PHIL setups. The assessment of the laboratory exercises by the students is clearly positive underlining the value of PHIL simulation for power system education.

**Index Terms**—Distributed generation, experiential learning, frequency control, laboratory education-training, microgrids, real-time power hardware-in-the-loop simulation, short circuit studies, voltage control.

## I. INTRODUCTION

**L**ABORATORY education provides a link between theory and real world offering valuable practical experience to students. The necessity to incorporate laboratory exercises in the power systems domain has been recognized since decades. In the last years, the wide-spread integration of DG and the on-going transformation of traditional power systems to smart grids demand new material in the power system curriculum. Accordingly, appropriate laboratory exercises need to be introduced. Several institutions have recognized this need and are contributing to laboratory education in this field [1]–[6].

Laboratory education on power systems is usually performed with simulation software [6], [7] or less frequently with dedicated hardware setups [1]–[3], [5]. On the other hand, laboratory education on power electronics and electric machines is typically performed with hands-on exercises using physical models

or real hardware, as the focus is on the component level. The limited use of real hardware on power system education is obviously due to the difficulty and cost of having a realistic power system setup in the lab (including generators, transformers, lines, loads, OLTC, DG inverters). As a result, small educational hardware setups usually perform specific functions and cannot be easily used for a wide range of experiments.

Several decades ago, analogue transmission line models and miniature generators were used at universities and AC network analysers at utilities [8]. The emergence of computers and the development of advanced dedicated software packages allowed analysis, research and education in power systems based on digital simulation, due to its flexibility, possibility to create complicated models, friendly graphical user interfaces, low cost etc. Although this evolution opened new paths in education, it deprived the students from the physical understanding of phenomena and their familiarization with power system hardware [8], [9].

Real-time Hardware-In-the-Loop (HIL) simulation is the connection of hardware equipment to a real-time simulated system (e.g. distribution network) executed in a Digital Real-Time Simulator (DRTS) [10]. At Controller Hardware-In-the-Loop (CHIL) simulation [11], a hardware controller is tested (e.g. controller of an inverter, relay) whereas at PHIL [12]–[14] a hardware power device is tested (e.g. inverter, motor). HIL simulation merges simulation and hardware testing providing hardware experience to the students while exploiting the advantages of digital simulation. The following features of HIL simulation are beneficial for educational purposes:

- 1) The students face a real-time system (like a SCADA), where they can perform actions and monitor the operation in realistic conditions. The flexibility, ease of modelling and designing test scenarios of digital simulation is maintained.
- 2) The connection of real hardware devices such as DG inverters, microgrids, relays can be realised, so students can see the operation of real apparatus. Measurement of actual magnitudes and control of the real devices is a valuable experience.
- 3) Components that are not available in the lab (e.g. OLTC, diesel generator) can be simulated in real-time and their interaction with hardware devices can be studied.
- 4) Challenging tests, such as faults, can be performed safely and conveniently in a real-time simulation environment without hazardous effects or equipment stress. The type, duration and location of faults can be easily modified by

Manuscript received July 13, 2016; revised September 29, 2016; accepted November 22, 2016. Date of publication December 29, 2016; date of current version August 17, 2017. This work was supported in part by the European Commission within the Horizon 2020 framework ERIGrid Project under Grant 654113. Paper no. TPWRS-01063-2016.

The authors are with the Smart Grids Research Unit, School of Electrical and Computer Engineering, National Technical University of Athens, Zografou 15780, Greece (e-mail: kotsa@power.ece.ntua.gr; vkleft@mail.ntua.gr; nh@power.ece.ntua.gr).

Color versions of one or more of the figures in this paper are available online at <http://ieeexplore.ieee.org>.

Digital Object Identifier 10.1109/TPWRS.2016.2633201

the students, which would be difficult in a fully hardware setup.

Real-time CHIL simulation has been used numerous times for educational purposes [15] in domains such as, control systems [16] and machine drives [17]. Concerning power system education, CHIL simulation has been mostly applied for protection system studies, such as in [18], where a commercial hardware relay was tested at different types of faults on a real-time simulated network, as part of a university course. An interactive platform to assess advanced distribution automation on smart grids for educational purposes was implemented in [19], where the users could incorporate protective algorithms and automation solutions (such as adaptive protections and reconfiguration methods to optimize the grid). In [6] real automation infrastructure (SCADA, controller etc) was connected to a simulated PV inverter and R-L-C circuit to perform anti-islanding detection tests for the training of lab personnel. Real-time simulation without connection of hardware devices (i.e. not HIL) was used in [18] for student projects on frequency control, flexible AC transmission systems, voltage stability, transient stability and was proposed in [20] for education on protection coordination studies with multiple fault scenarios.

The potential of PHIL simulation for lab education however, has been much less explored, as it is a newer and more complex technique than CHIL (amplification is necessary and stability/accuracy needs to be ensured). PHIL simulation allows the investigation of complex interactions between physical power apparatus and simulated systems in a realistic way, thus promoting the transition from component testing to system testing.

In this paper, PHIL simulation is employed for the first time for hands-on laboratory education on important topics of modern power systems and its value as an educational tool is demonstrated. Section II provides an overview of the laboratory exercises including organizational matters, learning objectives, topics and methodology. Four laboratory exercises are described in Section III accompanied by a description of the laboratory of the National Technical University of Athens (NTUA). A preliminary, simplified version of these exercises with limited use of PHIL simulation for demonstration only, was reported by the authors of this paper in [21]. Section IV reports the student feedback. Section V concludes the paper.

## II. OVERVIEW OF THE LABORATORY EXERCISES

### A. *Experiential Education*

Experiential education is a philosophy according to which educators engage their students directly to the object of knowledge and later on to a focused reflection relative to that engagement in order to increase knowledge, develop skills, clarify values, and develop their capacity to contribute to their communities. According to the philosopher and educational reformer John Dewey [22], learning is promoted not through books and lectures, but is left to emerge during the elaboration of the experiences of students themselves. Students are encouraged to get personally involved in projects, experiments etc and during that involvement they are “internally enforced” to learn them.

This educational approach has been described as “learning by doing”.

In 1984 Kolb [23] suggested a four-stage learning cycle to describe what is happening during the transformation of the experiences. According to that cycle the initial concrete experience is being elaborated and reflected upon (reflective observation) in order for the learner to reach an abstract conceptualization, which is the third stage of the learning cycle. That abstract concept is being applied in real life situations (active experimentation) so that a new concrete experience emerges which is elaborated and reflected upon and so on. Kolb’s cycle has been used in engineering technology courses [24], where usually lab exercises are incorporated into engineering courses [25].

In the following sections, the laboratory exercises performed in the framework of two basic, undergraduate courses on Electric Energy Systems Analysis (5 credits each at the European Credit Transfer and Accumulation System (ECTS)) taught at the School of Electrical and Computer Engineering of NTUA are presented, taking into account the four-stage experiential approach of Kolb’s cycle. It should be noted that the authors do not claim that experiential education can by any means replace class lectures, but it can very well complement and support the educational process.

### B. *Learning Objectives, Selected Topics and Methodology*

The main learning objectives of the laboratory exercises are:

- 1) Understanding fundamentals of power system operation.
- 2) Understanding important contemporary issues due to the integration of DG: technical challenges, benefits and perspectives.
- 3) Familiarization with hardware components including measurement and control.

To achieve these objectives the laboratory exercises start from the fundamentals of traditional power system operation, integrating gradually DG related topics in order to assist the students to understand the transition of the traditional system to the more complex decentralized environment. The selection of the topics which is described next is in line with the learning objectives.

During the classroom lectures the students are taught fundamentals of power system operation, such as primary frequency control (synchronous generators - droop control), voltage control (capacitors, OLTC) and short circuit analysis (synchronous generators induction motors/generators models, asymmetric conditions). The challenges of DG integration have been superficially addressed in the two basic courses, while they are taught in detail in later elective courses. During the experiments, the DG integration topics are offered to the students directly in the lab (concrete experience) without in-depth theoretical knowledge. In particular, voltage rise as the main technical constraint for DG integration in rural distribution networks, DG contribution to faults and the operation of microgrids are topics of particular interest, since several non-interconnected medium and small size islands are operated in Greece.

In this context, four topics are selected for the laboratory exercises:

- 1) Parallel operation of synchronous generators - parallel operation with DG
- 2) Voltage control of distribution networks - contribution of DG
- 3) Short circuit studies - contribution of power electronics interfaced DGs
- 4) Microgrid operation and control

The methodology applied is a hands-on approach combined with experiential learning, when possible. Four laboratory exercises are grouped in two sessions with a duration of 50 minutes each. The students are divided in eight groups of five or six students and during a laboratory session each group attends successively the tests at the two work benches available, thanks to the double PHIL setup (described in Section III-A). The laboratory sessions are carried out during the weekly two 2-hour blocks of the course. At the end of each laboratory session, the students are asked to fill in short reports based on measurements and reply to simple numerical exercises which account for 10% of the course mark.

After each experiment, suitable questions on real problems are posed to facilitate understanding, taking into account the student's existing knowledge (reflective observation). Guided conversations with the students or direct instruction, when considered necessary, lead to new concepts (abstract conceptualization). On this ground new experiments are performed (active experimentation and new concrete experience). The reports at the end of the session aim to reflect the laboratory experience (reflective observation).

### III. DESCRIPTION OF THE LABORATORY EXERCISES

#### A. Laboratory Infrastructure

A low voltage single-phase microgrid is operated at the Electric Energy Systems laboratory of NTUA that comprises PV panels (1.1 kWp), a small wind turbine (1.7 kW), battery energy storage (lead acid: 60 V, 250 Ah, 3.3 kW), controllable loads and a controlled interconnection to the local low voltage grid. The battery bank, the PV generator and the wind turbine are connected to the AC grid via fast-acting DC/AC power converters. The converters are suitably controlled to permit the operation of the system either interconnected to the low voltage network (grid-connected), or in stand-alone (island) mode, with a seamless transition from the one mode to the other. The loads of the microgrid include 15 kW of controllable resistive loads, 2.5 kVar of controllable inductive loads and additional lighting appliances and a motor. Three additional PV inverters are operated (2 kW, 2.5 kW and 3 kW respectively) which can be connected to the microgrid. The individual inverters and the microgrid are used as the hardware components of the PHIL experiments at the laboratory exercises and for research purposes.

Moreover, two additional microgrids are operated (3-phase and 1-phase). A SCADA system has been developed to monitor and control the laboratory components using a programmable logical controller, several meters, cards etc. The laboratory is equipped with three PV simulator units, two AC grid simulators (i.e. power amplifiers) and three industrial protection

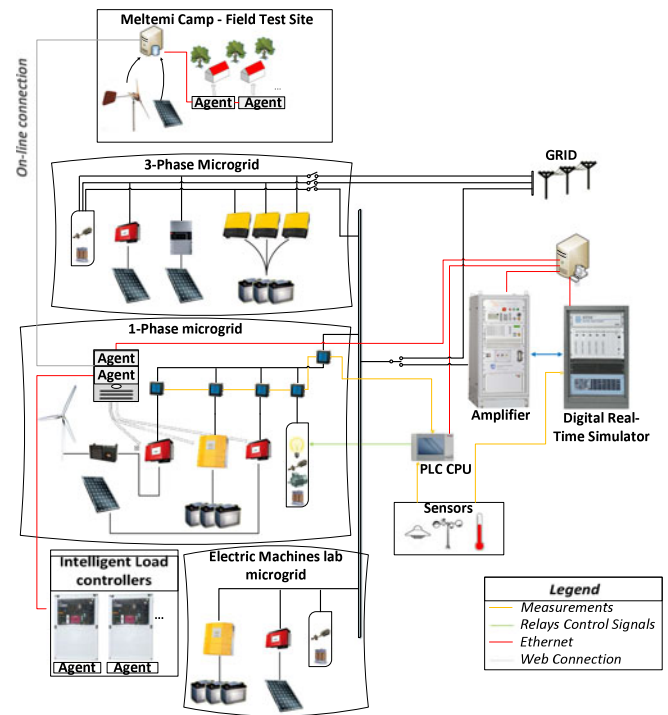

Fig. 1. Schematic diagram of the laboratory infrastructure.

relays. A flexible power electronic platform comprising three DC/DC converters and a DC/AC converter is programmable in Matlab/Simulink software. Moreover, ten intelligent load controllers (embedded systems equipped with analog and digital inputs/outputs, TCP/IP connectivity and load switches) enable the implementation of multi-agent systems. The schematic diagram of the laboratory is depicted in Fig. 1 and a more detailed description can be found in [26].

The DRTS contains several processing cards operating in parallel, as well as various analog and digital inputs and outputs. Dedicated software is used to design the electric circuit, control parameters in real-time, monitor simulation variables etc. The connection of a hardware power device (e.g. inverter) to the DRTS, namely PHIL simulation, is possible via a suitable power interface, which comprises an amplification unit and sensor. The voltage of a specific node from the simulation is amplified and applied to the hardware device and the sensor measures the current of the hardware device and sends it back to the simulation to close the loop [12]. This procedure is not straightforward as the time-delay introduced in the closed loop can lead to instability and also deteriorates the accuracy of the experiment. Therefore, a stability analysis (theoretic or/and dynamic simulation) is necessary before performing the PHIL experiment and appropriate protection schemes must be applied (software and hardware). A low pass filter is inserted on the feedback current in order to achieve stability, however reducing the accuracy [13]. Using the shifting impedance method [14] part of the software impedance is transferred on the hardware side in order to achieve stability without compromising the accuracy (applied in Section III-C). It must be noted that the understanding of these PHIL related issues by the students is not in the scope of the laboratory

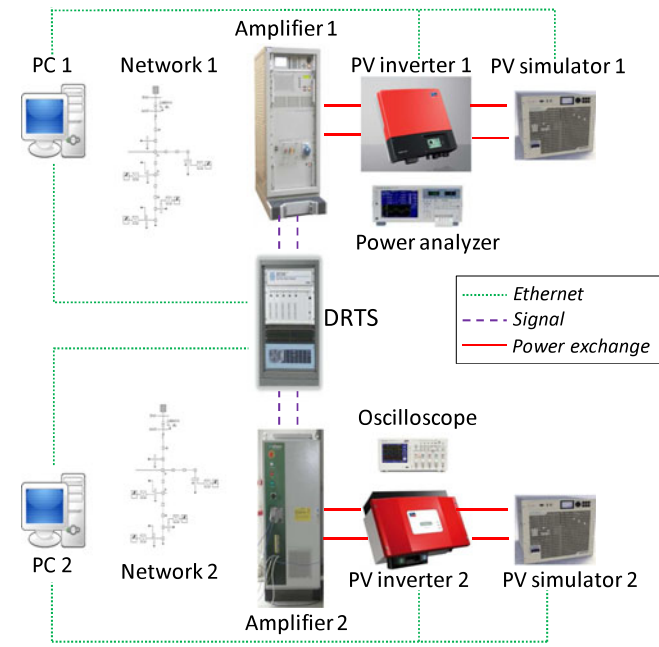

Fig. 2. Lab infrastructure for the hands-on training of students: Double PHIL configuration.

exercises, although the interfacing method is briefly explained (i.e. voltage amplification, current measurement).

The transition from a demonstration lab to a hands-on lab is described next. The lab is equipped with the two prevailing technologies of power amplifiers: a linear amplifier and a switched-mode amplifier. In this way it is possible to perform either a single PHIL experiment with two hardware power devices connected to different network nodes, or two independent PHIL experiments, each with its own simulated network and hardware power device. For educational purposes the latter configuration is employed, as it allows two independent experiments to be performed at the same time. Apart from the two amplifiers and two hardware power devices (i.e. inverters), it is also necessary to run two independent network models in the one DRTS rack controlled by two PCs. The aforementioned double PHIL configuration is illustrated in Fig. 2. Two independent PV simulator modules are connected to the DC side of the PV inverters, as the active power of the PVs needs to be controlled from different PCs. Modern PV inverters with advanced functions are used, which allow access to the user (e.g. to send a reactive power set-point, set a specific droop characteristic, curtail the active power) from the dedicated software of the manufacturer.

### B. Parallel Operation of Synchronous Generators – Integration of DG

A simple network consisting of two synchronous generators (including prime-movers, governors and automatic voltage regulators), distribution lines and a load is provided in the DRTS. The students change the active power of the load at the DRTS software and measure the active power of each synchronous generator and the operating frequency (steady-state and minimum or maximum value).

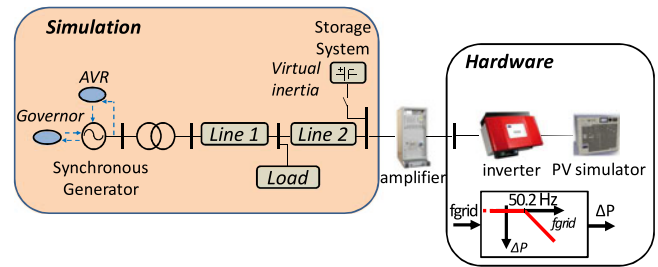

Fig. 3. Parallel operation of a synchronous generator, hardware PV inverter and storage with virtual inertia (PHIL simulation).

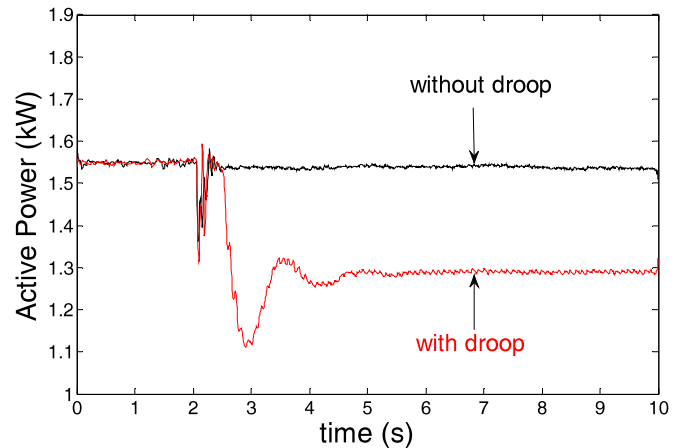

Fig. 4. Active power of the hardware PV inverter with and without  $P(f)$  droop control.

An actual PV inverter replaces the one synchronous generator and is connected to the simulated network in the DRTS (PHIL configuration shown in Fig. 3). The irradiation from the PV simulator is increased and the students note the increase in the system frequency (concrete experience). A problem-based learning approach is applied based on the “50.2 Hz problem”, which was noted in 2011. According to the standards at that time, the DGs had to disconnect at frequency values exceeding 50.2 Hz, meaning that in this case, several GWs of PV generation would be simultaneously disconnected from the network affecting system stability [27]. The students are asked to solve this problem and comment on how DG can participate to primary frequency control (reflective observation). The students are led to the solution of applying a  $P(f)$  droop characteristic at the PV inverter similar to conventional generation (abstract conceptualisation).

Next the  $P(f)$  droop characteristic of the PV inverter is activated (required by recent standards [28], shown on the right side of Fig. 3). The active power of the simulated load is decreased (step) and again the active load is shared between the synchronous generator and the DG (active experimentation). The active power of the PV inverter with and without droop control is shown together with the system frequency in Figs. 4 and 5, respectively. From the results it is clear that the decrease of the active power of the physical inverter based on its droop characteristic leads to an improved frequency response compared to the operation without droop control (Fig. 5). It is understood that

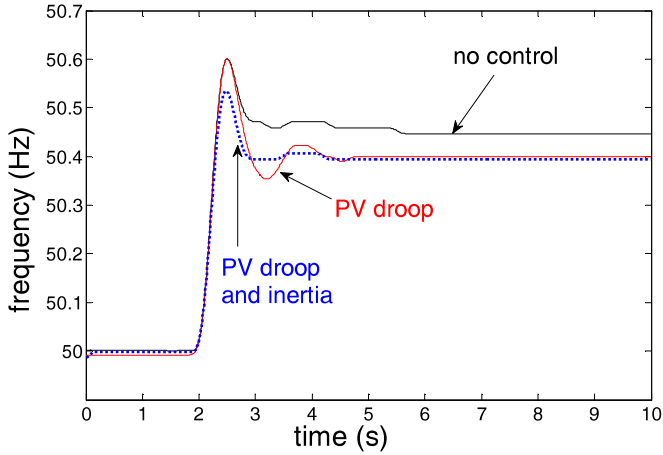

Fig. 5. Frequency without  $P(f)$  control, with  $P(f)$  control of the hardware PV inverter and combination with virtual inertia provided by the storage system.

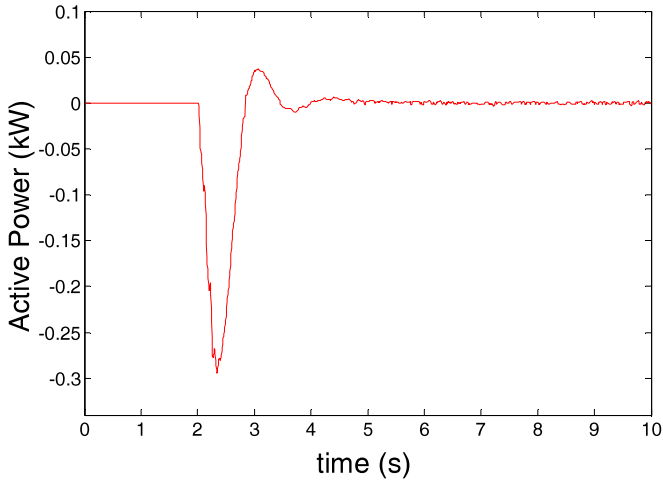

Fig. 6. Active power of the storage system providing virtual inertia.

in cases of low load and high DG production the active power of the DG is controlled without the need of a communication network.

Moreover, the capability of inverter-based DG and storage to compensate the reduced rotational inertia of the power system due to the increased DG integration is demonstrated making use of the “virtual synchronous generator” concept [29]. Accordingly, a storage system emulates the rotational inertia of synchronous generators following equation (1). The storage system is simulated in the DRTS and its active power during the PHIL test is shown in Fig. 6. The improved frequency response at dynamic conditions is shown in Fig. 5.

$$P_{storage} = k_i \frac{d\omega}{dt} \quad (1)$$

The experiments are designed, so that the students are actively involved, e.g. they set the  $P(f)$  droop parameters of the PV inverter via its software interface, experiment with different gains of the inertia emulation ( $k_i$ ) and change the load in the DRTS and the irradiation in the hardware PV simulator. Moreover, the students measure the active power of the hardware PV

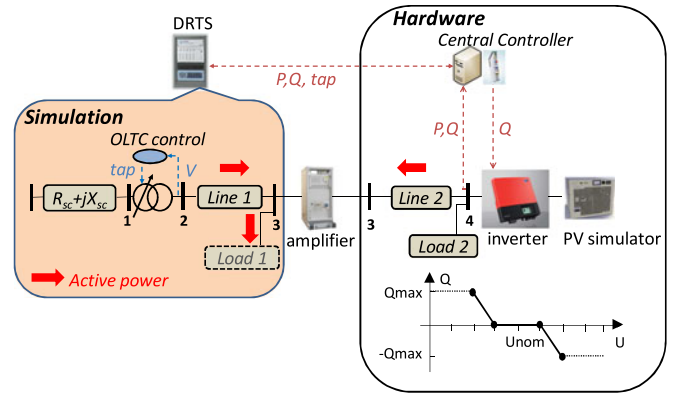

Fig. 7. Voltage control by DG, OLTC and centralised coordinated control (PHIL and CHIL simulation).

inverter and the system frequency with a power analyser and the active power of the synchronous generator and frequency in the DRTS. At the end of the exercise, they are asked to provide a report based on the measurements, i.e.: to calculate for the given test-case (synchronous generator and PV operating with droop control) the power sharing and frequency and compare with the experimental results. Additional questions aim to explain why DG droop control is mainly used for over-frequency and not so often for under-frequency events.

### C. Voltage Control of Distribution Networks - Integration of DG

The students are already familiar with the theory of conventional voltage control approaches, such as the use of capacitors and OLTC and the effect of the active and reactive power of the load on the voltage, as shown in equation (2).

$$\Delta V \approx \frac{P \cdot R_{line} + Q \cdot X_{line}}{V_{load}} \quad (2)$$

Fig. 7 shows the overall setup for the second experiment. A hardware PV inverter and a load bank (*Load 2*) are connected to a weak distribution network fed by a transformer equipped with an OLTC. As a transformer with OLTC is not available in the lab it is simulated in the DRTS via PHIL simulation. An additional load (*Load 1*) is inserted in the real-time simulation.

Conventional voltage control is applied first without the presence of the PV inverter and the simulated load (*Load 1*). The OLTC controller employs line-drop compensation, i.e. it estimates the voltage at the end of the feeder based on the measured voltage and current on the secondary side of the transformer. The hardware load (*Load 2*) is gradually increased, leading to a voltage drop below the lower threshold of the OLTC. The OLTC changes the tap position in order to bring the voltage within the desired range.

Next, the physical PV inverter is connected at the end of the long feeder and the OLTC gets deactivated. The students control the active power of the PV simulator by changing the irradiation for a given  $I-V$  curve via its software environment. While keeping *Load 2* low, they steadily increase the active power of the PVs from zero to nominal and observe the voltage

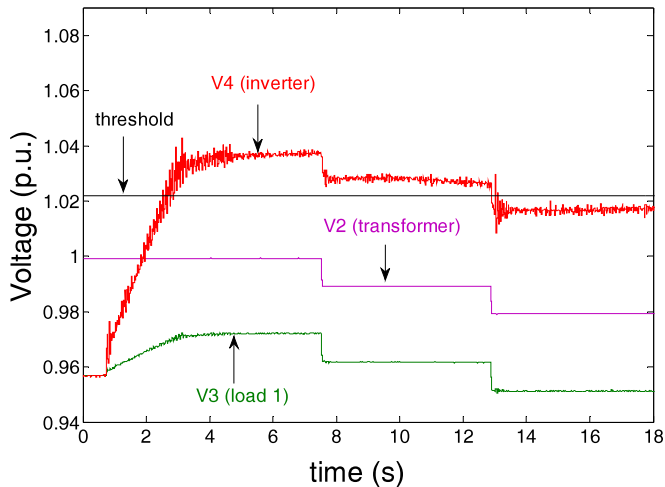

Fig. 8. The PV production raises the inverter's voltage ( $V_4$ ) which is then decreased by the OLTC, however reducing further the voltage of *Load 1* ( $V_3$ ).

rise occurring at the inverter's terminal (concrete experience). The students try to solve this overvoltage problem, which is one of the main challenges faced by the integration of DG in rural distribution networks (reflective observation).

Extending equation (2) to include also generation the students understand the effect of reactive power absorption by the PV inverter on the voltage rise (abstract conceptualization). The students send reactive power absorption set-points to the PV inverter (until minimum  $\cos \varphi = 0.8$ ) via its software interface, monitor the voltage and validate its effect (active experimentation). Then a reactive power vs. voltage droop curve is implemented (i.e.  $Q(U)$  shown in Fig. 7) locally in the inverter's control, as required by recent standards [28], and the experiment is repeated with similar results. The need for DG to support the grid by providing ancillary services is highlighted (as also shown at the exercise in Section III-B). Additional solutions are discussed, which can also be derived from equation (2) (i.e. grid reinforcement, DG active power curtailment).

Another series of experiments involves the use of the OLTC. The OLTC gets activated and regulates the voltage at the end of the feeder, while the PV inverter operates at unity power factor. A large load (*Load 1* in Fig. 7) is now connected to the network and the resulting active power flow is shown in Fig. 7 (the reactive power is not shown for simplicity as it weakly affects this experiment). Obviously, the previous simple line-drop compensation estimation is not valid due to the presence of *Load 1*, therefore the voltage at the end of the feeder is measured and sent to the OLTC controller. Fig. 8 shows that the OLTC manages to reduce the overvoltage at the PV inverter's bus, however it generates a higher under-voltage at the bus of *Load 1*. The necessity of a coordinated operation of existing voltage control appliances (e.g. OLTC) and modern devices (e.g. PV and storage inverters) is noted. More complex interactions of OLTC and DG [14] can be used.

An optimal coordinated voltage control scheme is applied next, where a central controller measures the active and reactive power at all nodes and sends reactive power set-points to the

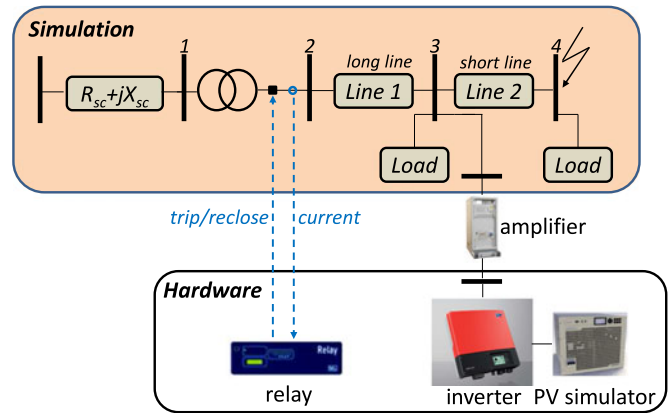

Fig. 9. Short circuit testing of inverter-based DG (PHIL and CHIL simulation).

PV inverter and tap changing commands to the OLTC. The objectives of the optimization problem are the minimization of the voltage deviations, number of tap changes and line losses. A hardware controller, executing the optimization algorithm, exchanges signals with the DRTS (i.e. CHIL) and the hardware PV inverter. The implemented setup is shown in Fig. 7.

During the experiments the students measure the active-reactive power, voltage-current (rms), vector diagram and waveforms of voltage and current (to see the phase shift and changes in the amplitude of the current) on the hardware PV inverter and the transformer voltage, the number of tap changes, voltage step and time-delay of the OLTC in the DRTS. The students report the influence of active and reactive power on the voltage at different R/X ratios of the lines (i.e. low voltage, medium voltage, high voltage lines) among other topics. In this way, the coupling of active power with voltage in networks with high R/X ratios (e.g. underground low voltage cables) is highlighted, contrary to networks with low R/X ratio (e.g. overhead high voltage lines) where the voltage is predominantly influenced by reactive power.

#### D. Short Circuit Studies- Integration of DG

These experiments show fundamental concepts of traditional short circuit analysis, but mainly focus on the behaviour of inverter-based DG (e.g. PVs, wind turbines with permanent magnet synchronous generators) during faults.

First, the students apply short circuits at different locations of a simulated low voltage distribution network in the DRTS and measure the resulting current. A hardware relay monitors and controls a simulated circuit breaker at the secondary of the transformer (Fig. 9). The students observe that as the location of the fault moves away from the transformer, the short circuit current flowing from the upstream network is decreased (due to the greater equivalent impedance) and the trip time of the hardware relay is increased. Also the voltage at the different buses is monitored during the short circuits.

Prior to connecting the physical PV inverter to the network in a PHIL configuration, the location of the three-phase short circuit and of the PV inverter need to be determined, (i.e. chosen between buses 2,3,4 of Fig. 9), so that during the fault the

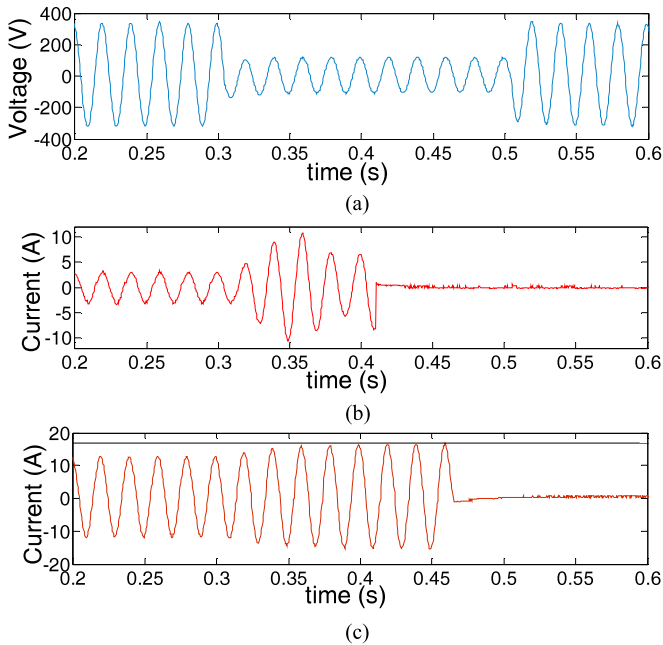

Fig. 10. Short circuit behavior of the PV inverter at low power (b) and nominal power (c). The current limitation is visible.

voltage of the inverter bus drops to approximately  $1/3$  of its pre-fault value. The PV inverter is neglected in this approximate calculation, as its nominal power is small and its fault contribution is much smaller than the current drawn from the upstream network. The loads are neglected for the same reason. Having achieved this, the physical inverter is connected to the simulated network and a three-phase short circuit is applied, as illustrated in Fig. 9.

The physical PV inverter operates at low power before the fault and its behaviour during the fault is recorded by an oscilloscope, as shown in Fig. 10(b). The short circuit current is increased to approximately 3 times the pre-fault current in response to the voltage drop at  $1/3$  (concrete experience). This happens because the control algorithm of PV inverters is normally designed to maintain operation at fixed active power (and power factor) for a constant input from the DC side (reflective observation). The experiment is repeated with nominal power. Fig. 10(c) demonstrates that there is a limit at approximately 1.3 times of the nominal current which does not allow a higher increase (concrete experience). It is concluded that the current limitation (typically below two times of the nominal current, depending on the manufacturer) is incorporated in the control algorithm of the inverter in order to respect the thermal limits of its switching devices (abstract conceptualisation). A second PV inverter of a different manufacturer is used and the experiment is repeated (active experimentation). It is noted that the inverters exhibit a partly different behaviour during the fault i.e. gradual increase of the current until the maximum value (see Fig. 10(c)) or fast increase of the current until the maximum value and then gradual reduction. In this way, the students learn that the contribution of inverter-based DG depends on the pre-fault operating condition of the inverter, the voltage drop at its terminal and

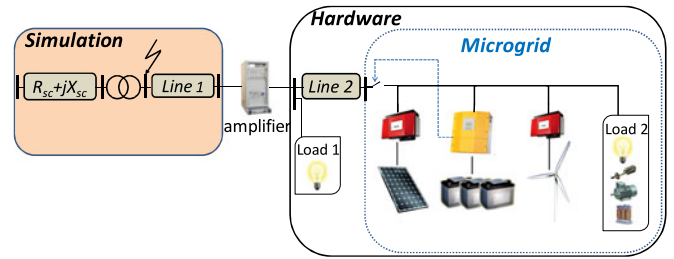

Fig. 11. Setup for microgrid experiments (PHIL simulation).

its specific control algorithm. The usual assumption in practical calculations of 1.5-2 times of the nominal current is tested [30]. An interesting analysis of the actual operation of inverter-based DG during faults can be found in [31].

### E. Microgrid Operation and Control

The laboratory microgrid described in Section III-A is used in a PHIL configuration (see Fig. 11). At first, the microgrid [32] operates in grid-connected mode and the students note the active power of the PVs, wind turbine, storage and load of the microgrid from the SCADA developed at NTUA and also the active power flow at the secondary winding of the transformer in the DRTS (concrete experience). The key role of the storage system as the most controllable unit is highlighted and its applications, such as balancing the PV and wind turbine production, peak shaving, voltage control, self-consumption etc, are discussed. For the experiment it is assumed that the network or market operator requires a specific amount of active power from the microgrid as a controllable entity for technical (e.g. congestion, voltage violation) or economic reasons [33]. The students take the role of the microgrid operator which has to implement the required set-point by controlling the storage system and potentially the controllable loads. Based on measurements of the active power of the PVs, wind turbine, and load of the microgrid, the required active power of the battery inverter (absorption or production) is calculated, in order to achieve the required set-point (reflective observation). The set-point is implemented in the commercial battery inverter via software developed in-house (active experimentation). Fig. 12 shows the active power of the different components and the upstream network, where the set-point is received (at  $t = 35$  s, the battery starts to absorb active power) followed by an irradiation reduction in the PV simulator (at  $t = 67$  s, the battery decreases the absorption and starts to produce active power). The importance of different layers of control in the smart grid is explained (abstract conceptualization) accompanied with aspects of information and communication technologies.

Then a fault occurs at the transformer (in the DRTS at Fig. 11) producing a significant voltage dip which forces the microgrid to switch to island mode. Subsequently, the battery inverter becomes the grid-forming unit. The students have the opportunity to experience the seamless transition from grid-connected to island mode by observing that both the PV inverter and the load of the microgrid remain connected (*hardware load 2*: lights on), however the load outside the microgrid is disconnected

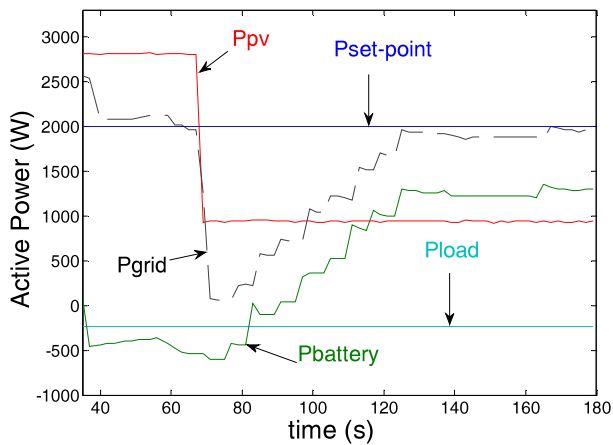

Fig. 12. The students control the active power of the battery inverter to fulfil a set-point of 2 kW production from the microgrid. (The small deviation between  $P_{\text{set-point}}$  and  $P_{\text{grid}}$  is due to the online approximate calculation by the students).

(*hardware load 1*: lights off). The capability of microgrids to improve the reliability and maintain the power supply during external disturbances and grid interruptions is illustrated.

Island operation of the microgrid is examined next, where the voltage and frequency are defined by the battery inverter. The students observe the active power balance and confirm that the battery inverter balances the difference between the production (PVs and wind turbine) and consumption. Moreover, the capability of the battery inverter to operate with droop control, similar to a synchronous generator, is explained. This is particularly useful when more controllable units (e.g. battery inverters) are connected to the same islanded microgrid (power sharing is achieved similarly to Section III-B [32]). The students learn that islanded microgrids are installed in remote off-grid locations, such as rural communities in developing regions etc.

#### IV. STUDENT FEEDBACK

Questionnaires were prepared in order to get feedback from the students regarding the evaluation of the exercises and the student's opinion on relevant matters. Questions 1 to 6 refer to the evaluation of the exercises and questions 7 to 10 to their opinion on important matters. The students are asked to provide a response from 1 to 5 using the Likert scale (1: I strongly disagree, 2: I disagree, 3: I am neutral, 4: I agree, 5: I strongly agree). Two open ended questions were also included concerning proposals for improvement and general comments. Each laboratory session is attended by approximately 50 students. The questionnaires were handed to the students at the end of both laboratory sessions, therefore about 95 questionnaires were received (96% of the participants provided feedback). The questions and the feedback of the students are shown in the upper part of Table I.

A sample of the responses on the questionnaires is shown in Fig. 13 (questions 5, 6 and 7). The students found the exercises overall interesting (55%) and very interesting (34%) (question 6). They highly appreciated the use of real-time simulation for educational purposes (37% *I agree*, 55% *I strongly agree* - question 7) despite the complexity of the implementation

TABLE I  
RESULTS OF THE STUDENT SURVEYS

Question:	Mean	Standard Deviation
1) The topics of the laboratory exercise are interesting	4.35	0.58
2) The presentation of the laboratory exercise is adequate	4.27	0.63
3) The active participation and use of equipment by the students is encouraged	4.03	0.95
4) The laboratory exercise has helped me understand the operation of traditional power systems	3.61	0.75
5) The laboratory exercise has helped me understand the operation of modern power systems with distributed generation	4.16	0.69
6) The laboratory exercise is interesting (in overall)	4.23	0.63
7) Real-time simulation is a useful educational tool	4.45	0.71
8) The use of hardware equipment by the students is more interesting than a simple demonstration	4.39	0.70
9) The introduction of modern topics (distributed generation) increases my interest in the laboratory exercises and in the power system courses in general	4.46	0.60
10) The introduction of additional laboratory exercises in the power system courses is useful	4.43	0.68
Graduates feedback		
i) Real-time simulation is a useful tool for student dissertations	4.75	0.43
ii) The use of hardware equipment at a dissertation is more interesting/useful than pure simulation or literature review	4.75	0.43

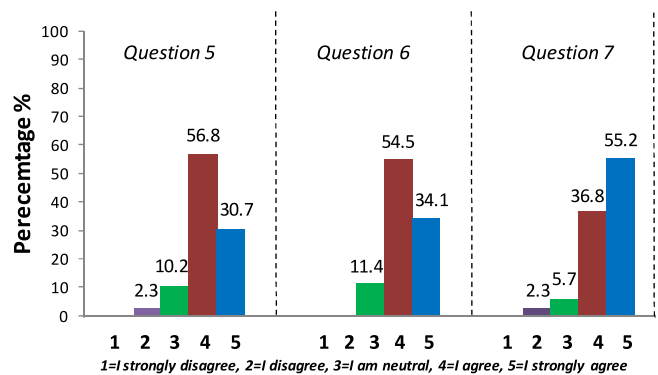

Fig. 13. Student's feedback on questions 5, 6 and 7.

(amplifiers, sensors etc). They were also satisfied with the level of their involvement and use of equipment (42% *I agree*, 35% *I strongly agree* - question 3). Moreover, they prefer hands-on approaches compared to demonstrations (51% *I strongly agree* - question 8), they find the introduction of modern topics motivating (51% *I strongly agree* - question 9) and are very keen to participate to more laboratory exercises (53% *I strongly agree* - question 10).

The lowest rating concerned the knowledge on the operation of the traditional power system (38% *I am neutral* - question 4) and will be considered for the exercises next year. The feedback about possible improvements and informal discussions led to the conclusion that it is useful to increase the duration of the exercises in order to allow more use of equipment by the students.

Based on Kolb's theories, the more lab exercises are similar to real life situations, the more attractive they are to students, as shown in their answers in question 7. They were not satisfied with simple demonstration (question 8), probably because in that situation only stage 1 and 2 of Kolb's cycle are visited



(concrete experience and reflective observation), not necessarily leading to stage 3 (abstract conceptualization) and definitely not reaching stage 4 (active experimentation). On the contrary, performing experiments with the hardware equipment meant that they went through all stages of the Kolb's cycle. Consequently, this experiment seems to have more significance to them, probably due to the involvement of more senses [34], [35] and more complicated mental procedures, which indicates their active involvement.

Another interesting educational aspect is that students become eager to use real-time HIL simulation/experiments for their diploma dissertations. Starting from 2011, ten undergraduate students have selected topics involving real-time simulations at the Electric Energy Systems laboratory of NTUA. The main topics are: stability and accuracy in PHIL simulation, amplifier control for PHIL simulation, voltage rise mitigation by PVs (PHIL), control of hybrid off-grid systems (PHIL and CHIL), PV inverter controls development and testing (CHIL), coordinated voltage control of distribution networks (CHIL), demand response (CHIL) and real-time modelling of wind turbine for frequency control. In particular, the development of the PHIL facility was assisted by the results of two dissertations on the real-time modelling in the DRTS and control of the switched mode amplifier. Since then, seven publications have been co-authored by students (one journal, four international conferences and two national conferences). The dissertations using real-time simulation account for almost 30% of the dissertations performed in hardware at the Electric Energy Systems laboratory.

A questionnaire was distributed to the ten graduates and the feedback is shown at the lower part of Table I. The participants rated highly the use of real-time simulation for their dissertations (25% *I agree*, 75% *I strongly agree* - question i). They noted strong impact on their learning experience, appreciated the resemblance to real life conditions and the novelty of the approach. The main disadvantage noted was the additional difficulty/burden on the modelling phase, the need for well-trained supervisors and physical limitations of the equipment used. Moreover, the graduates find the hardware experience far more interesting and motivating than pure simulations and literature review (25% *I agree*, 75% *I strongly agree* - question ii).

## V. CONCLUSION

PHIL simulation can contribute to the debate between hardware and simulation advocates, by combining the advantages of both approaches. This work shows that PHIL simulation can assist to familiarize students with the hardware lab, while keeping the flexibility and modeling capability of digital simulation.

The paper reports on hands-on laboratory exercises covering modern, DG related topics of power system operation performed at NTUA. PHIL simulation was applied to simulate the components that were not physically available in the lab and to study system-level interactions. A comprehensive double PHIL configuration was developed creating two lab benches for the students. Experiential learning was applied for the experiments. The students evaluated the exercises clearly positively

and highly appreciated real-time simulation for their education. Moreover, they showed keen interest in the integration of modern topics to the lab exercises and in obtaining hands-on experience on actual devices.

## ACKNOWLEDGMENT

The authors gratefully acknowledge the support of Alex Georgopoulos, Professor at the Aristotle University of Thessaloniki, on the educational aspects of the paper. Moreover, the authors acknowledge the support of Marios Maniatopoulos, Achilleas Markou, Iasonas Kouveliotis-Lysikatos and Vasileios Paspiliotopoulos, researchers at NTUA, who have helped the organization and supervision of the laboratory exercises.

## REFERENCES

- [1] S. Santoso, M. Lwin, J. Ramos, M. Singh, E. Muljadi, and J. Jonkman, "Designing and integrating wind power laboratory experiments in power and energy systems courses," *IEEE Trans. Power Syst.*, vol. 29, no. 4, pp. 1944–1951, Jul. 2014.
- [2] M. Rasheduzzaman, B. H. Chowdhury, and S. Bhaskara, "Converting an old machines lab into a functioning power network with a microgrid for education," *IEEE Trans. Power Syst.*, vol. 29, no. 4, pp. 1952–1962, Jul. 2014.
- [3] I. Kuzle, J. Havelka, H. Pandžić, and T. Capuder, "Hands-On laboratory course for future power system experts," *IEEE Trans. Power Syst.*, vol. 29, no. 4, pp. 1963–1971, Jul. 2014.
- [4] H. Qinran, L. Fangxing, and C. Chien-fei, "A smart home test bed for undergraduate education to bridge the curriculum gap from traditional power systems to modernized smart grids," *IEEE Trans. Educ.*, vol. 58, no. 1, pp. 32–38, Feb. 2015.
- [5] A. S. Deese, "Development of smart electric power system (SEPS) laboratory for advanced research and undergraduate education," *IEEE Trans. Power Syst.*, vol. 30, no. 3, pp. 1279–1287, May 2015.
- [6] T. Strasser, M. Stifter, F. Andr n, and P. Palensky, "Co-simulation training platform for smart grids," *IEEE Trans. Power Syst.*, vol. 29, no. 4, pp. 1989–1997, Jul. 2014.
- [7] P. S. Georgilakis, G. A. Orfanos, and N. D. Hatziaargyriou, "Computer-assisted interactive learning for teaching transmission pricing methodologies," *IEEE Trans. Power Syst.*, vol. 29, no. 4, pp. 1972–1980, Jul. 2014.
- [8] G. G. Karady, G. T. Heydt, K. J. Olejniczak, H. A. Mantooth, S. Iwamoto, and M. L. Crow, "Role of laboratory education in power engineering: Is the virtual laboratory feasible? I," in *Proc. Power Eng. Soc. Summer Meeting*, Seattle, WA, USA, 2000, pp. 1471–1477.
- [9] G. G. Karady, "Roll of laboratory education in electrical power engineering education," in *Proc. IEEE Power Energy Soc. General Meeting*, Pittsburgh, PA, USA, 2008, pp. 1–3.
- [10] M. O. Faruque *et al.*, "Real-Time simulation technologies for power systems design, testing, and analysis," *IEEE Power Energy Technol. Syst. J.*, vol. 2, no. 2, pp. 63–73, Jun. 2015.
- [11] A. Hasanzadeh, C. S. Edrington, N. Stroupe, and T. Bevis, "Real-Time emulation of a high-speed microturbine permanent-magnet synchronous generator using multiplatform hardware-in-the-loop realization," *IEEE Trans. Ind. Electron.*, vol. 61, no. 6, pp. 3109–3118, Jun. 2014.
- [12] M. Steurer, C. S. Edrington, M. Solderbeck, W. Ren, and J. Langston, "A megawatt-scale power hardware-in-the-loop simulation setup for motor drives," *IEEE Trans. Ind. Electron.*, vol. 57, no. 4, pp. 1254–1260, Apr. 2010.
- [13] G. Lauss, M. O. Faruque, K. Schoder, C. Dufour, A. Viehweider, and J. Langston, "Characteristics and design of power hardware-in-the-loop simulations for electrical power systems," *IEEE Trans. Ind. Electron.*, vol. 63, no. 1, pp. 406–417, Jan. 2016.
- [14] P. Kotsampopoulos, F. Lehfuss, G. Lauss, B. Bletterie, and N. Hatziaargyriou, "The limitations of digital simulation and the advantages of PHIL testing in studying distributed generation provision of ancillary services," *IEEE Trans. Ind. Electron.*, vol. 62, no. 9, pp. 5502–5515, Sep. 2015.
- [15] P. M. Menghal and A. J. Laxmi, "Real time simulation: A novel approach in engineering education," in *Proc. 3rd Int. Conf. Electron. Comput. Technol.*, Kanyakumari, India, Apr. 2011, pp. 215–219.

- [16] S. Usenmez, U. Yaman, M. Dolen, and A. B. Koku, "A new hardware-in-the-loop simulator for control engineering education," in *Proc. IEEE Global Eng. Educ. Conf.*, Istanbul, Turkey, Apr. 2014, pp. 1–8.
- [17] O. A. Mohammed, S. Liu, Z. Liu, N. Abed, and S. Ganu, "Innovations in teaching energy systems utilizing an integrated simulation environment," in *Proc. IEEE Power Eng. Soc. General Meeting*, San Francisco, CA, USA, Jun. 2005, pp. 1192–1197.
- [18] A. Srivastava and N. Schulz, "Applications of a real-time digital simulator in power system education and research," in *Proc. 116th Annu. Conf. Expo., Amer. Soc. Eng. Educ.*, Austin, TX, USA, 2009, pp. 14.226.1–14.226.10.
- [19] D. Celeita, M. Hernandez, G. Ramos, N. Penafiel, M. Rangel, and J. D. Bernal, "Implementation of an educational real-time platform for relaying automation on smart grids," *Elect. Power Syst. Res.*, vol. 130, pp. 156–166, Jan. 2016.
- [20] C. Dufour, C. Andrade, and J. Bélanger, "Real-time simulation technologies in education: A link to modern engineering methods and practices," in *Proc. 11th Int. Conf. Eng. Technol. Educ.*, Ilhéus, Brazil, Mar. 2010, pp. 1–5.
- [21] P. Kotsampopoulos, G. Messinis, A. Vassilakis, V. Kleftakis, A. Rigas, and N. Hatzigiorgiou, "Laboratory education on distributed energy resources making use of an advanced infrastructure," in *Proc. 9th MedPower Conf.*, Athens, Greece, Nov. 2014, pp. 1–6.
- [22] J. Dewey, *Experience and Education*. West Lafayette, IN, USA: Kappa Delta Pi, 1938/1998.
- [23] D. A. Kolb, *Experiential Learning*. Englewood Cliffs, NJ, USA: Prentice-Hall, 1984.
- [24] R. J. Durkin, "Experiential learning in engineering technology: A case study on problem solving in project-based learning at the undergraduate level," *J. Eng. Technol.*, vol. 33, no. 1, pp. 22–29, Spring 2016.
- [25] M. Abdulwahed and Z. K. Nagy, "Applying Kolb's experiential learning cycle for laboratory education," *J. Eng. Educ.*, vol. 98, no. 3, pp. 283–294, Jul. 2009.
- [26] G. Messinis *et al.*, "A multi-microgrid laboratory infrastructure for smart grid applications," in *Proc. 9th MedPower Conf.*, Athens, Greece, Nov. 2014, pp. 1–6.
- [27] J. Boemer *et al.*, "Overview of German grid issues and retrofit of photovoltaic power plants in Germany for the prevention of frequency stability problems in abnormal system conditions of the ENTSO-E region continental Europe," in *Proc. 1st Int. Workshop Integr. Sol. Power Power Syst.*, Aarhus, Denmark, vol. 24, 2011.
- [28] P. Kotsampopoulos, N. Hatzigiorgiou, B. Bletterie, and G. Lauss, "Review, analysis and recommendations on recent guidelines for the provision of ancillary services by distributed generation," in *Proc. IEEE Int. Workshop Intell. Energy Syst.*, Vienna, Austria, Nov. 2013, pp. 185–190.
- [29] V. Karapanos, P. Kotsampopoulos, and N. Hatzigiorgiou, "Performance of the linear and binary algorithm of virtual synchronous generators for the emulation of rotational inertia," *Elect. Power Syst. Res.*, vol. 123, pp. 119–127, Jun. 2015.
- [30] T. N. Boutsika and S. A. Papathanassiou, "Short-circuit calculations in networks with distributed generation," *Elect. Power Syst. Res.*, vol. 78, no. 7, pp. 1181–1191, Jul. 2008.
- [31] C. A. Plet and T. C. Green, "Fault response of inverter interfaced distributed generators in grid-connected applications," *Elect. Power Syst. Res.*, vol. 106, pp. 21–28, Jan. 2014.
- [32] N. Hatzigiorgiou, *Microgrids: Architectures and Control*. Hoboken, NJ, USA: Wiley, Jan. 2014.
- [33] M. H. Gomes and J. T. Saraiva, "Allocation of reactive power support, active loss balancing and demand interruption ancillary services in MicroGrids," *Elect. Power Syst. Res.*, vol. 80, no. 10, pp. 1267–1276, Oct. 2010.
- [34] A. Kontinen and N. Moilanen, "Experiential learning with multisensory and digital elements," *Interdiscip. Stud. J.*, vol. 4, no. 1, pp. 28–40, Jan. 2015.
- [35] J. Pine and J. Gilmore, *The Experience Economy*. Boston, MA, USA: Harvard Bus. Rev. Press, 2011.



**Panos C. Kotsampopoulos** (S'12) received the Diploma degree in electrical and computer engineering from the National Technical University of Athens (NTUA), Athens, Greece, in 2010. He is currently working toward the Ph.D. degree in the area of distributed energy resources at the Electric Power Division, NTUA, where he is currently involved in research projects and is a Tutor in power system analysis courses. He was a guest researcher with the Austrian Institute of Technology AIT, Vienna, Austria, in 2012 and 2013. His research interests include real-time hardware-in-the-loop simulation, distributed generation, ancillary services, and education. He is a member of the Technical Chamber of Greece.



**Vasilis A. Kleftakis** received the Diploma degree in electrical and computer engineering from the National Technical University of Athens (NTUA), Athens, Greece. He is a Researcher in the Electric Energy Systems Laboratory, NTUA. His research interests include real-time simulation and hardware-in-the-loop, distributed generation, microgrids, and electrification of rural areas. He is currently a member of the CIGRE WG C6.30 "The Impact of Battery Energy Storage Systems on Distribution Networks" and the IEC System Evaluation Group Committee

entitled "Low Voltage Direct Current Applications, Distribution and Safety for use in Developed and Developing Economies." He is a member of the Technical Chamber of Greece.



**Nikos D. Hatzigiorgiou** (S'80–M'82–SM'90–F'09) is Chairman and CEO of the Hellenic Distribution Network Operator. Since 1984, he has been with the Power Division of the Electrical and Computer Engineering Department of the National Technical University of Athens, and since 1995, he has been a full professor in Power Systems. From February 2007 to September 2012, he was Deputy CEO of the Public Power Corporation (PPC) of Greece, responsible for Transmission and Distribution Networks, island DNO and the Center of Testing, Research and Prototyping. He is past Chair of the Power System Dynamic Performance Committee, Distinguished member of CIGRE, and past Chair of CIGRE SC C6 "Distribution Systems and Distributed Generation". He is chair of the Advisory Council of the EU Technology Platform on SmartGrids. He is a member of the Energy Committee of the Athens Academy of Science. He has participated in more than 60 R&DD Projects funded by the EC and the industry. He is author of the book *Microgrids: Architectures and Control* and of more than 200 journal publications and 500 conference proceedings papers.