









Optical Frequency Tuning for Coherent THz Wireless Signals

Haymen Shams , *Member, IEEE*, Katarzyna Balakier , *Member, IEEE*, Luis Gonzalez-Guerrero ,
 Martyn J. Fice , *Member, IEEE*, Lalitha Ponnampalam , *Member, IEEE*, Chris S. Graham ,
 Cyril C. Renaud , *Senior Member, IEEE*, and Alwyn J. Seeds , *Fellow, IEEE*

(Invited Paper)

Abstract—THz wireless signals have become of interest for future broadband wireless communication. In a scenario where the wireless signals are distributed to many small remote antenna units, this will require systems which allow flexible frequency tuning of the generated THz carrier. In this paper, we demonstrate experimentally the implementation of two tuning methods using an optical frequency comb generator for coherent optical frequency tuning in THz wireless-over-fiber systems. The first method is based on using a photonic integrated circuit optical phase lock loop (OPLL) subsystem implemented as a high quality optical filter for single comb line selection and optical amplification. The OPLL generates an optical carrier, which is frequency and phase stabilized in reference to one of the optical comb lines with a frequency offset precisely selectable between 4 and 12 GHz. The second method is based on optical single sideband suppressed carrier (SSB-SC) modulation from the filtered comb line using an optical IQ modulator. With this technique, it is possible to suppress the other unwanted optical tones by more than 40 dB. This generated optical carrier is then heterodyned with another filtered optical comb line to generate a tuneable and stable THz carrier. The full system implementations for both methods are demonstrated by transmitting THz wireless signal over fiber with 20 Gb/s data in QPSK modulation. The system performance and the quality of the generated THz carrier are evaluated for both methods at different tuned THz carrier frequencies. The demonstrated methods confirm that a high quality tuneable THz carrier can easily be implemented in systems where dynamic frequency allocation is required.

Index Terms—Fiber wireless, high-speed wireless, microwave photonics, optical frequency comb, optical heterodyning, Photonic THz generation, radio-over-fiber.

I. INTRODUCTION

PHOTONIC generation of millimeter wave (mm-wave) signals is becoming a promising technology for generating

Manuscript received March 2, 2018; revised May 14, 2018 and June 5, 2018; accepted June 5, 2018. Date of publication June 11, 2018; date of current version August 30, 2018. This work was supported in part by the U.K. Engineering and Physical Sciences Research Council under the Coherent TeraHertz Systems Programme Grant EP/J017671/1, in part by the Converged Optical & Wireless Access Networks under Grant EP/P003990/1, and in part by the European Commission through the European project iPHOS under Grant 257539. (Corresponding author: Haymen Shams.)

The authors are with the Department of Electronic and Electrical Engineering, University College London, London WC1E 7JE, U.K. (e-mail: h.shams@ucl.ac.uk; k.balakier@ucl.ac.uk; uceelgo@ucl.ac.uk; m.fice@ucl.ac.uk; l.ponnampalam@ucl.ac.uk; c.graham@ucl.ac.uk; c.renaud@ucl.ac.uk; a.seeds@ucl.ac.uk).

Color versions of one or more of the figures in this paper are available online at <http://ieeexplore.ieee.org>.

Digital Object Identifier 10.1109/JLT.2018.2846031

high quality, easily tuned RF carriers in spectral regions with wide bandwidth available for broadband signal modulation [1], [2]. THz wireless-over-fiber has recently become of great interest for future ultra-broadband wireless communication, where a large free bandwidth can be used to cope with increasing demands from consumer applications [3]. Many works have already been reported which demonstrate transmission of wireless THz signals with data rate of more than 100 Gbps using high spectral efficiency modulation formats and multicarrier transmission systems [4]–[8]. Most of these systems are based on generating the THz carrier using optical heterodyning of two free-running lasers at the high speed photodetector. This has the great advantage of simplifying the transmitter design, and offers easy tuneability of the RF carrier and frequency allocation. However, the generated RF carrier encounters frequency fluctuations due to the phase noise and relative frequency instabilities of the two uncorrelated laser sources. This leads to a reduction of the quality of the modulated signal and impairs the system performance. Therefore, digital signal processing (DSP) at the receiver will be required to remove the offset frequency, and recover the phase of the modulated signal. This increases the system latency and complicates the digital post-processing algorithms at the receiver.

The International Telecommunication Union (ITU) specifies the frequency tolerance to be less than ± 1.9 MHz for radio frequencies in the range of 30–275 GHz [9]. Practically, this cannot be obtained using two free running lasers over practical operating temperature ranges [10]. A dual wavelength source monolithically integrated on the same chip is a compact solution and generates a more stable mm-wave, where the two lasers experience the same temperature conditions [11]–[13]. However, there are still some instabilities in the carrier frequency, requiring feedback thermal stabilization [14]. In order to generate a stable RF carrier with high spectral purity, the phases of the two optical sources have to be locked together. This can be achieved if they are generated from the same optical source. An optical frequency comb generator (OFCG) is an effective method for generating phase correlated optical tones equally spaced by the driving RF-frequency. Several techniques have been demonstrated to generate optical combs based on modulating the optical carrier using an optical modulator or semiconductor devices [15]–[17]. Two optical tones, spaced by

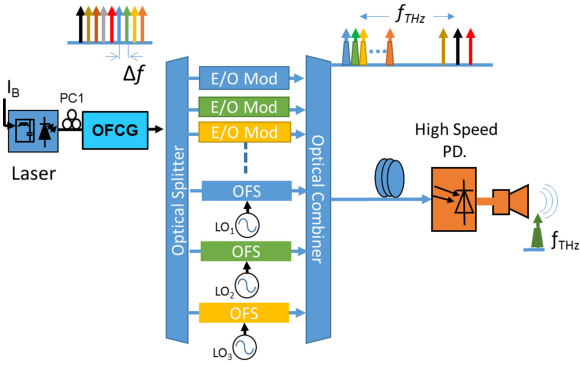

Fig. 1. Block diagram of photonic generation of frequency tunable THz signal. OFCG: optical frequency comb generator; OFS: optical frequency shifter; PC: polarization controller; E/O Mod: electro-optic modulator, PD: photodiode.

the required offset frequency, can then be selected by using narrow optical filters or optical laser locking techniques [13], [18]. Using an OFCG has shown improved performance of the generated RF carrier and reduction of the complex computations at the DSP receiver [19]. However, this method constrains the frequency tuneability of the RF carrier to multiples of the fixed frequency spacing between the comb lines of the OFCG, and limits the flexibility of the frequency spectrum for the entire system.

In this paper, we present two methods for coherent optical frequency tuning of the generated THz wireless signals combined with an OFCG. Fig. 1 shows the proposed system for the THz wireless-over-fiber link. The comb lines are split for optical modulation with data, and the other optical lines are used for optical local oscillators (LOs). Those optical LOs can be tuned using optical frequency shifters (OFSs), and then mixed with the optical modulated signals at the photodetector. The first proposed method is based on using a photonic integrated circuit optical phase lock loop (OPLL) as a sub-system, consisting of a slave laser whose phase is locked to that of the comb line with additional tuneable frequency offset [20]. This frequency difference is precisely defined by the RF reference source that also forms part of the heterodyne OPLL. The OPLL system is a well-known technique for generating a coherent carrier with offset frequency [21]–[23]. The second method is achieved by generating an optical carrier from single sideband suppressed carrier (SSB-SC) modulation of the optical IQ modulator. Several works have previously demonstrated the realization of optical frequency shifting based on the optical SSB-SC method. These works were based on using a single, or dual electrode Mach-Zehnder modulator (MZM) [24]–[27]. The OPLL and optical SSB-SC techniques used in the paper are implemented experimentally in a THz wireless-over-fiber link, and demonstrated with 10 GBaud QPSK signals at different offset frequency tuning. The system performance is evaluated for both proposed methods, and their relative merits discussed.

II. FREQUENCY TUNEABILITY USING OPTICAL PHASE LOCK LOOP (OPLL)

This section describes the OPLL method as a sub-system for optical filtering and tuning of the optical carrier. The OPLL

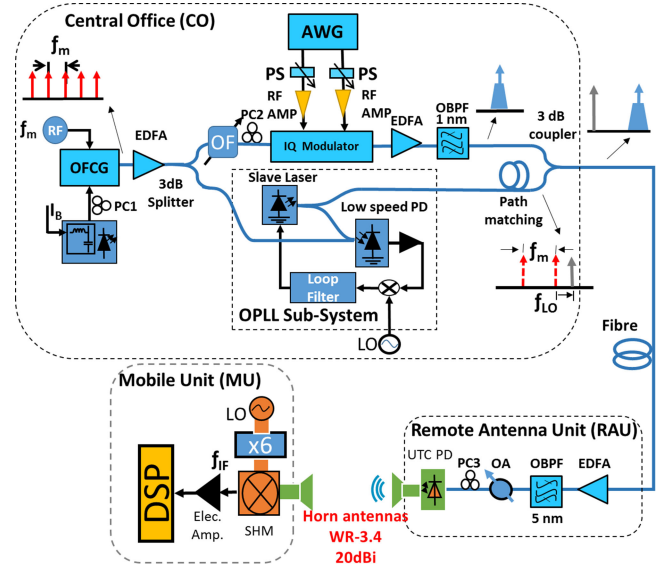

Fig. 2. Experimental arrangement diagram for THz frequency tuneability using OPLL. OFCG: optical frequency comb generator; EDFA: Erbium doped fiber amplifier; PS: phase shifter; PC: polarization controller; OBPF: optical bandpass filter; AWG: arbitrary waveform generator; OPLL: optical phase lock loop; OA: optical attenuator; UTC: uni-travelling carrier; PD: photodiode; SHM: second harmonic mixer; DSP: digital signal processing.

consists of a photonic integrated circuit (PIC) and an electronic feedback loop. The PIC includes a distributed Bragg reflector (DBR) laser, semiconductor optical amplifier (SOA), and 12 GHz microwave photodiode [18]. All opto-electronic components are monolithically integrated on a single InP-based chip with dimensions of 2 mm × 6 mm [28]. The electronic feedback loop was designed using commercially available electronic components for controlling the frequency and phase locking of the slave laser.

The experimental arrangement for the optical tunable coherent THz frequency system using the OPLL is shown in Fig. 2. A single wavelength laser source (Santec tunable laser) of 10 kHz linewidth at 1533.14 nm is used to generate the optical comb. The optical comb produces optical phase correlated tones spaced by 15 GHz using a dual-drive MZM [29]. The optical comb is then optically amplified and split using a 3-dB coupler into two optical paths. One optical tone is selected using an optical filter with a 10 GHz bandwidth, and used for optical modulation with data using an IQ optical modulator. The modulating signal was generated from an arbitrary waveform generator (AWG) from Tektronix (AWG7000) with sampling rate of 50 GSamples/s, electrically amplified, and fed into both RF inputs of the IQ modulator (Covega BW < 20 GHz). However, in the lower optical branch, the entire optical comb is coupled into the OPLL sub-system to filter out one of the optical lines. In the OPLL sub-system, the signal from the OFCG is heterodyned mixed with the integrated slave laser on an integrated PD. The output of the heterodyned signal is then amplified, and its phase compared with an RF reference. This generates a feedback signal for adjusting the phase of the slave laser. It should be noted that the frequency offset between the comb line and the slave laser is precisely specified by the frequency of the RF reference, and tuned with the same precision as the RF synthesizer. In this

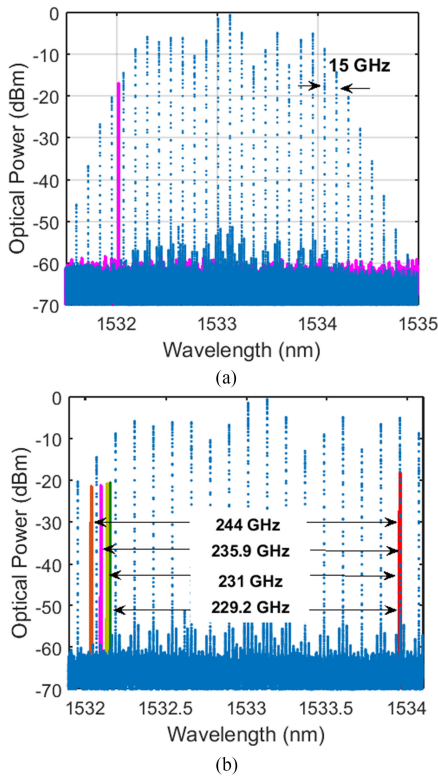

Fig. 3. Optical spectra of (a) the OFCG (dotted blue lines), and the OPLL sub-system output (solid pink line), and (b) the OFCG (dotted blue lines), and the optical lines generated from the OPLL when the OPLL is locked at different offset frequencies; 4.2 GHz (green line), and 6 GHz (yellow line) spaced by 15 comb line from the selected comb line (red line) at the upper arm, and at 4.1 GHz (pink line) and 4 GHz (brown line) spaced by 16 comb lines.

particular OPLL, the offset frequency is between 4 and 12 GHz and is limited by the bandwidth of the photodiode integrated on the OPLL PIC and the other electronic components in the feedback loop circuit, but OPLLs with higher offset frequency have been reported in [30]. In order to tune the OPLL output to one of the optical comb lines, the wavelength of the slave laser is first set to be close to one of the desired optical comb lines by controlling the grating current of the DBR laser, and then the exact offset frequency is adjusted by the RF reference of the OPLL. Fig. 3(a) shows the optical spectra of the optical comb and the optical tone tuned using the OPLL. As can be seen, the optical comb lines are suppressed by more than 50 dB at the output of the OPLL sub-system (measured with 10 MHz resolution bandwidth), and there is only one optical tone generated from the OPLL, spaced from one of the comb lines by the offset frequency of the RF reference. The wavelength of the slave laser can be positioned on the lower or the upper side of the selected comb line. In Fig. 3(b), the RF reference is adjusted to give offset frequencies of 4.2 GHz and 6 GHz from an optical comb line which is separated by 15 comb lines (225 GHz) from the selected comb line in the upper arm in the schematic diagram. This gives THz carrier at 229.2 GHz and 231 GHz, respectively. To tune to higher THz carrier frequency, the wavelength of the slave laser is set to be close to the optical comb line spaced by 16 optical lines (240 GHz). This generates THz frequency of 235.9 GHz, and 244 GHz by using an LO frequency of 4.1 GHz, and 4.0 GHz, respectively. Instabilities in the locking occurs if

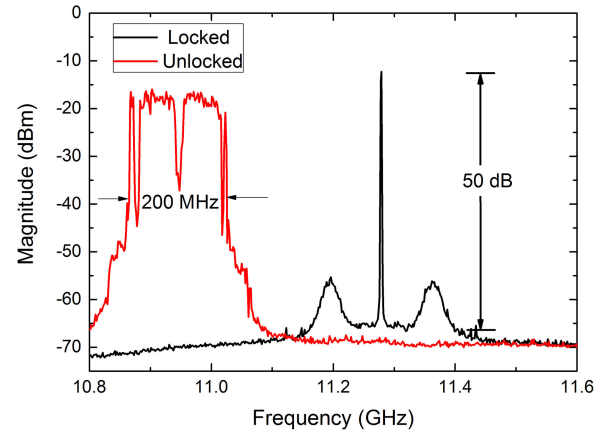

Fig. 4. Electrical spectra of the THz carrier down-converted to IF frequency when the OPLL is active and inactive. The resolution, and video bandwidth of the spectrum analyzer were set to 300 kHz, and 100 kHz, respectively.

the electrical LO is set to a frequency offset that falls in the middle between two optical comb lines. In this experiment, the optical comb lines are spaced by 15 GHz. This will allow only to set the frequency offset up to 7.5 GHz.

The OPLL output and the selected unmodulated optical carrier were heterodyned on an unpackaged uni-travelling photodiode (UTC-PD), and measured using an electrical spectrum analyzer (ESA) after down-conversion to an intermediate frequency (IF). Fig. 4 shows the measured electrical spectra for the cases when the OPLL is locked and unlocked, obtained for a 229.5 GHz THz carrier with a max hold function set to 20 seconds. When the OPLL is inactive, the slave laser is in a free running mode, and the frequency of the generated THz carrier fluctuates within a range of ~ 200 MHz. This is due to the thermal instabilities of the two free running lasers, and would require frequency tracking technique in the receiver. However, when the OPLL is locked to the optical comb line the THz frequency is fixed and shows an increase of the carrier power. The sideband peaks around the carrier (at the offset frequency of ± 80 MHz) result from the loop bandwidth limitation. When the OPLL is active, the phase noise of the generated carrier is kept at the low level within the loop bandwidth until the power rise of the sideband peaks (which remains less than -55 dBm). The sideband peaks are measured to be 48 dB lower than the generated carrier at resolution bandwidth of 300 kHz, and can be reduced even further by adjusting the loop gain [31]. Furthermore, the phase noise of the heterodyne mixing of the OPLL output with an optical comb line spaced at 34 GHz, 231 GHz, 234 GHz, 236 GHz, and 244 GHz were measured using a Rohde&Schwarz FSU43 spectrum analyzer, and compared with the phase noise of the RF synthesizer (operating at 15 GHz) used to generate the comb lines, as shown in Fig. 5. The phase noise measurements for frequencies at 231 GHz, 234 GHz, 236 GHz, and 244 GHz show the residual phase noise level of less than -85 dBc/Hz at 10 kHz offset from carrier, when the OPLL is active and locked at 4 GHz and 6 GHz offsets from the selected comb line. This is approximately 15 dB higher than the phase noise measurements at 34 GHz, as expected due to frequency multiplication [32]. We can also see the sideband peaks at 80 MHz resulting from the loop bandwidth of the OPLL. The spurious peaks at 70 kHz,

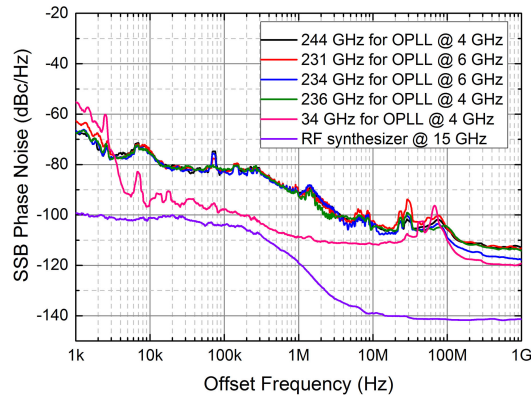

Fig. 5. Phase noise measurements of the heterodyne mixing between OPLL output and optical carrier spaced at 34 GHz, 231 GHz, 234 GHz, 236 GHz, 244 GHz, and RF synthesizer used in the OFCG.

and 30 MHz seem to be coupled from laboratory environment through the unpackaged OPLL.

In the central office (CO), the optical carrier was modulated with 10 Gbaud QPSK with a square root raised cosine (SRRC) filter of 0.1, and then combined with OPLL output. The optical path mismatch between the two arms was compensated by adding fiber to one of the optical paths. Then, the received optical signal at the remote antenna unit (RAU) was amplified by an erbium-doped fiber amplifier (EDFA) and filtered by a 5 nm optical bandpass filter before being photomixed on the UTC-PD. Horn antennas with 20 dBi gain were used at the transmitter and receiver. The received THz signal at the mobile unit (MU) was down-converted to the IF using a sub-harmonic mixer, with the LO provided by a $\times 6$ frequency multiplier from an RF source at approximately 12 GHz. The received signal is then electrical amplified and captured by a real time scope of 36 GHz bandwidth and sampling rate of 80 GSamples/sec. The recorded signal length was 10 μ sec which corresponds to 200,000 bits. The received signal is then processed offline, by digital down-conversion to the baseband, down sampling (2 Samples/symbol), channel equalization based on blind equalizer algorithm, carrier recovery, and then Viterbi-Viterbi algorithm for phase noise estimation. Then, the bit error ratio (BER) was calculated after signal demodulation by varying the injected optical power into the UTC-PD.

Fig. 6 shows the BER measurements versus the received electrical power for four THz signals at carrier frequencies of 229.2 GHz, 231 GHz, and 235.9 GHz. There are only small differences between the BER curves, and all the results are shown to be below the hard decision forward error correction (HD-FEC) limit of 3.8×10^{-3} for 7% overhead bits.

III. FREQUENCY TUNEABILITY USING OPTICAL SINGLE SIDE BAND SUPPRESSED CARRIER (OSSB-SC)

This section describes the operation of the SSB-SC method used to generate frequency tuneability of the THz carrier. This method is based on filtering one of the optical comb lines and using an optical IQ modulator to generate an optical SSB-SC signal. Fig. 7 shows the schematic diagram of the optical transmitter that is used in the CO in Fig. 2. In the lower optical

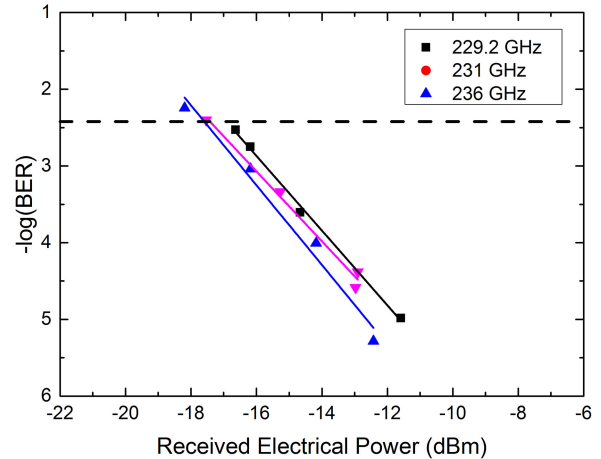

Fig. 6. BER measurements versus electrical received power where the THz carrier is tuned for three different frequencies.

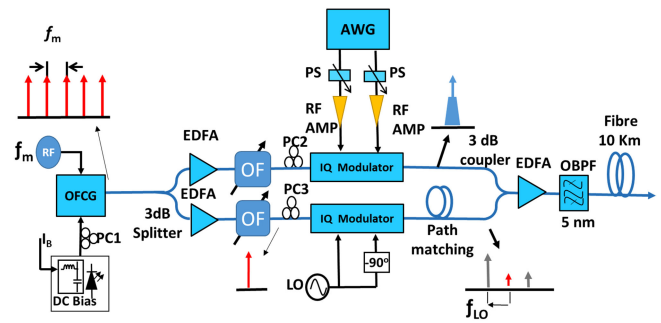

Fig. 7. Schematic diagram of the optical THz tuneability using OSSB-SC method.

branch, a narrow optical filter (Santec tunable filter) is used after an optical amplifier to select one of the optical comb lines. This optical line is modulated by driving both arms of the IQ modulator by an electrical LO. In order to generate SSB-SC, the electrical LO drives both arms of the optical IQ modulator (Photline, BW < 40 GHz) with the same magnitude, and 90° degree phase difference between them. In addition, the biases of the optical IQ modulator are set to the minimum transmission points. In theory, this should suppress totally the optical carrier, and one of the optical sideband signals. However, residual optical carrier and sideband can still be seen on the spectrum.

The offset frequency of the optical SSB-SC can be easily controlled by varying the frequency of the electrical LO, and can be tuned on the both sides of the optical carrier by changing the phase delay by $\pm 90^\circ$. Fig. 8 shows the optical spectra of the optical SSB-SC signal at two offset frequencies measured with an optical spectrum analyzer with a resolution bandwidth of 10 MHz. The optical spectrum shows the optical SSB-SC signal at the offset frequency of 4 GHz and 6 GHz from the filtered optical carrier with a strong suppression of 42 dB, and 34 dB for the other optical sideband, respectively. This has also been inspected in the electrical spectrum analyzer by combining the generated optical SSB-SC with another optical tone spaced by 240 GHz. Fig. 9 (b) shows the electrical spectrum of the down converted THz carrier spaced at 246 GHz. The generated carrier shows a clean, and fixed frequency signal with an electrical

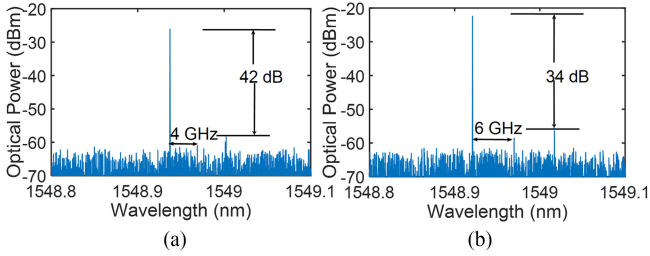

Fig. 8. Optical spectra for optical carrier tuning at frequency offset of 4 GHz, and 6 GHz.

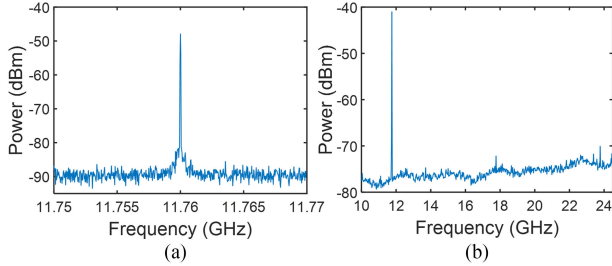

Fig. 9. Electrical spectra of the THz carrier after down-conversion to the IF frequency for (a) 240 GHz (RBW = 20 KHz, and VBW = 3 KHz), and (b) 246 GHz when it is tuned by 6 GHz electrical LO (RBW = 10 MHz, and VBW = 1 MHz).

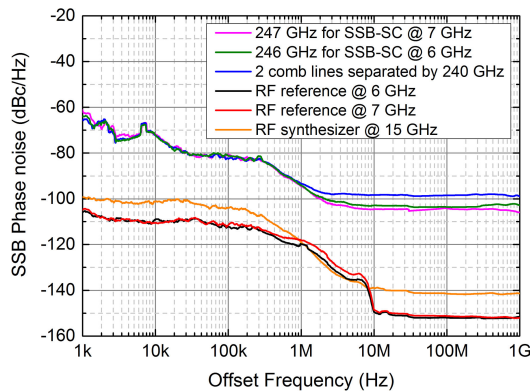

Fig. 10. SSB phase noise measurements for downconverted THz signal at different frequencies 240 GHz, 246 GHz, 247 GHz, RF reference of 6 GHz and 7 GHz, and the RF synthesizer at 15 GHz.

suppression to the unwanted peaks by more than 30 dB. The SSB phase noise was also obtained for the beat notes generated at 240 GHz, 246 GHz and 247 GHz, and the RF references at 6 GHz, 7 GHz and 15 GHz, as shown in Fig. 10. The measured values of the phase noise are almost the same, and higher than the phase noise measurement for the RF synthesizer at 15 GHz, used for the comb generation. This degradation in phase noise is nearly matched with the theoretical phase noise increases by $(20 \times \log(m) = 24 \text{ dB})$, where m is the multiplication number [33]. The observed value is -72 dBc/Hz at the offset frequency of 10 kHz.

We also evaluated the modulated THz signal after 10 km fiber transmission at the MU. The resulting BER is measured for 10 Gbaud QPSK at THz carriers of 240 GHz, 244 GHz and 246 GHz, as shown in Fig. 11. The THz carriers were selected to evaluate the signal quality from the nearest suppressed optical carriers. As can be seen, there is no penalty shown

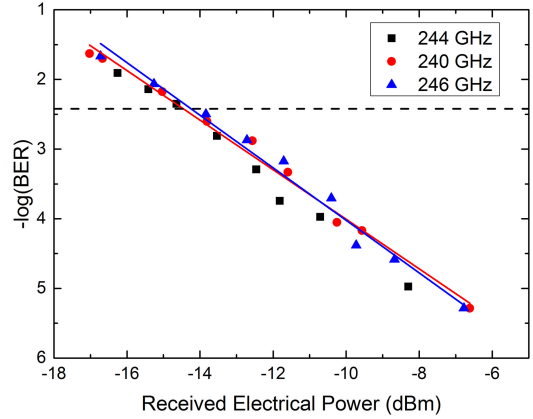

Fig. 11. BER measurements versus received electrical power at three different THz frequency signals.

in the BER measurements, and all BER curves are below the FEC limit. The SSB-SC results verify that the system performs well with using an SSB-SC modulation. However, this limit is higher by 2 dB than that was obtained in the OPLL method, resulted from more optical power generated from slave laser in the OPLL sub system.

IV. DISCUSSION

The generation of high quality THz wireless signals with accurately defined frequency and low phase noise is necessary for future broadband wireless communication. The presented OPLL for coherent THz tuning was realized using a foundry fabricated PIC with a commercial opto-electronic feedback loop. The offset frequency of the OPLL is in the range of 4 – 12 GHz, based on the current electronic component bandwidths. The OPLL works as high quality filter with suppression ratio of all unwanted optical comb lines of $> 50 \text{ dB}$. When the OPLL is active, the generated THz frequency carrier is very stable, and only sideband peaks at about 80 MHz offset from the carrier and more than 48 dB below the carrier power can be observed. In addition, this method is free from any spurious spectral components. However, the residual phase noise of the generated THz carrier will depend on the summed linewidths of the comb line, and the slave laser. This is due to the linewidth – time delay trade off [34]. In order to phase lock laser with the comb line with linewidth of 1 MHz, the delay within the opto-electronic feedback loop must be less than two nanoseconds. Photonic integration is a key to achieve this reduction of delay within the feedback loop. Moreover, the OPLL can offer optical gain, meaning that the optical power can be greater at the output than at the input of the OPLL. This is particularly important for systems that require high SNR. In this particular system, the OPLL is unpackaged and vulnerable to fiber misalignment which effectively reduces the power level of the optical reference signal to the optical feedback loop leading to loss of lock. Packaging the OPLL PIC will overcome this limitation.

The SSB-SC method showed an efficient and reliable technique to generate a tuned optical carrier. This is simply realized by using an optical IQ modulator and RF reference. The offset frequency can be tuned over a wide range limited by the modulation bandwidth of the optical modulator (40 GHz, in this

experiment). The optical carrier and sideband can be suppressed (>40 dB) by fine control of the bias in the optical modulator. The SSB-SC method is not limited by the laser linewidth, as in the OPLL method, and showed a stabilized THz carrier with no side peaks around the carrier. The main drawbacks of the SSB-SC scheme is that it is vulnerable to bias drifts of the modulator, and its large losses of the optical power (>30 dB) because the modulator is biased at low transmission points, and therefore needs optical amplification. The spurious spectral components observed from the optical carrier and the other sideband may cause signal distortion and power penalty on the transmission system, if these tones are not suppressed well. This solution could be improved further if another laser is used as a slave laser to filter only the tuned optical tone using optical injection locking, which would also give more optical power to the optical carrier at the expense of considerably increased complexity.

V. CONCLUSION

We have demonstrated experimentally techniques for the optical generation of stable, frequency tuneable THz wireless signals using the OPLL and SSB-SC methods. Both schemes enabled the generation of spectral purity THz carriers. The OPLL method gives strong suppression of the unwanted optical comb lines, and provides optical gain to the selected line. However, the performance of OPLL is limited with the summed linewidths of the comb line and the slave laser. On the other hand, the SSB-SC method suffers from unwanted spurious spectral components, and requires more optical amplification. The arbitrary THz carrier frequency generation in CO is a potential solution for dynamic and flexible carrier tuning for distributing THz signals to multiple RAUs.

REFERENCES

- [1] J. Capmany, B. Ortega, and D. Pastor, "A tutorial on microwave photonic filters," *J. Lightw. Technol.*, vol. 24, no. 1, pp. 201–229, Jan. 2006.
- [2] A. J. Seeds *et al.*, "Microwave photonics," *IEEE Trans. Microw. Theory Techn.*, vol. 50, no. 3, pp. 877–887, Feb. 2002.
- [3] A. Seeds, H. Shams, M. Fice, and C. Renaud, "TeraHertz photonics for wireless communications," *J. Lightw. Technol.*, vol. 33, no. 3, pp. 579–587, Feb. 2015.
- [4] H. Shams, M. J. Fice, L. Gonzalez-guerrero, C. C. Renaud, F. van Dijk, and A. J. Seeds, "Sub-THz wireless over fiber for frequency band 220–280 GHz," *J. Lightw. Technol.*, vol. 34, no. 20, pp. 4786–4793, Oct. 2016.
- [5] S. Jia *et al.*, "THz wireless transmission systems based on photonic generation of highly pure beat-notes," *IEEE Photon. J.*, vol. 8, no. 5, Oct. 2016, Art. no. 7905808.
- [6] X. Li *et al.*, "Fiber-wireless-fiber link for 128-Gb/s PDM-QPSK signal transmission at W-band," *IEEE Photon. Technol. Lett.*, vol. 26, no. 19, pp. 1948–1951, Oct. 2014.
- [7] X. Pang *et al.*, "Single channel 106 Gbit/s 16QAM wireless transmission in the 0.4 THz band," in *Proc. Opt. Fiber Commun. Conf. Exhib.*, 2017, Art. no. Tu3B.5.
- [8] X. Pang *et al.*, "260 Gbit/s photonic-wireless link in the THz band," in *Proc. IEEE Photon. Conf.*, 2017, pp. 6–7.
- [9] ITU-R, "ITU-R SM.1045-1 (07/1997) Frequency tolerance of transmitters," 1997.
- [10] A. Kanno, P. T. Dat, T. Kuri, I. Hosako, and T. Kawanishi, "Evaluation of frequency fluctuation in fiber-wireless link with direct IQ down-converter," in *Proc. Eur. Conf. Opt. Commun.*, 2014, pp. 6–8.
- [11] F. van Dijk, A. Accard, A. Enard, O. Drisse, D. Make, and F. Lelarge, "Monolithic dual wavelength DFB lasers for narrow linewidth heterodyne beat-note generation," in *Proc. 2011 Int. Top. Meet. Microw. Photon. jointly held 2011 Asia-Pacific Microw. Photon. Conf.*, 2011, pp. 73–76.
- [12] F. Van Dijk *et al.*, "Integrated InP heterodyne millimeter wave transmitter," *IEEE Photon. Technol. Lett.*, vol. 26, no. 10, pp. 965–968, May 2014.
- [13] K. Balakier *et al.*, "Optical injection locking of monolithically integrated photonic source for generation of high purity signals above 100 GHz," *Opt. Exp.*, vol. 22, no. 24, pp. 29404–29412, Nov. 2014.
- [14] L. Ponnampalam *et al.*, "Injection-locked integrated twin DBR lasers for mm-wave generation," in *Proc. Eur. Workshop Photon. Solutions Wireless, Access-House Netw.*, 2009, pp. 3–4.
- [15] C. C. Renaud *et al.*, "A monolithic MQW InP/InGaAsP-Based comb generator," in *Proc. 2006 Int. Top. Meet. Microw. Photon.*, 2006, pp. 1–4.
- [16] R. Wu, V. R. Supradeepa, C. M. Long, D. E. Leaird, and A. M. Weiner, "Generation of very flat optical frequency combs from continuous-wave lasers using cascaded intensity and phase modulators driven by tailored radio frequency waveforms," *Opt. Lett.*, vol. 35, no. 19, pp. 3234–6, Oct. 2010.
- [17] X. Xie *et al.*, "Low-noise and broadband optical frequency comb generation based on an optoelectronic oscillator," *Opt. Lett.*, vol. 39, no. 4, pp. 785–8, 2014.
- [18] K. Balakier, L. Ponnampalam, M. J. Fice, C. C. Renaud, and A. J. Seeds, "Integrated semiconductor laser optical phase lock loops," *IEEE J. Sel. Top. Quantum Electron.*, vol. 24, no. 1, Jan./Feb. 2018, Art. no. 1500112.
- [19] H. Shams *et al.*, "100 Gb/s multicarrier THz wireless transmission system with high frequency stability based on a gain-switched laser comb source," *IEEE Photon. J.*, vol. 7, no. 3, Jun. 2015, Art. no. 7902011.
- [20] H. Shams *et al.*, "Coherent frequency tuneable THz wireless signal generation using an optical phase lock loop system," in *Proc. IEEE Top. Meet. Microw. Photon.*, 2017, pp. 2–5.
- [21] R. J. Steed *et al.*, "Hybrid integrated optical phase-lock loops for photonic terahertz sources," *IEEE J. Sel. Top. Quantum Electron.*, vol. 17, no. 1, pp. 210–217, Jan. 2011.
- [22] N. Satyan, W. Liang, A. Kewitsch, G. Rakuljic, and A. Yariv, "Coherent power combination of semiconductor lasers using optical phase-lock loops," *IEEE J. Sel. Top. Quantum Electron.*, vol. 15, no. 2, pp. 240–247, Mar./Apr. 2009.
- [23] M. Lu, H. Park, E. Bloch, L. Johansson, M. Rodwell, and L. a. Col-dren, "An integrated heterodyne optical phase-locked loop with record offset locking frequency," in *Proc. Opt. Fiber Commun. Conf.*, 2014, Art. no. Tu2H.4.
- [24] M. Y. Frankel and R. D. Esman, "Optical single-sideband suppressed-carrier modulator for wide-band signal processing," *J. Light. Technol.*, vol. 16, no. 5, pp. 859–863, May 1998.
- [25] V. Ferrero and S. Camatel, "Optical phase locking techniques: An overview and a novel method based on single side sub-carrier modulation," *Opt. Exp.*, vol. 16, no. 2, pp. 818–828, 2008.
- [26] C. W. Chow, C. H. Wang, C. H. Yeh, and S. Chi, "Analysis of the carrier-suppressed single-sideband modulators used to mitigate Rayleigh backscattering in carrier-distributed PON," *Opt. Exp.*, vol. 19, no. 11, pp. 1294–1296, 2011.
- [27] A. Loayssa, D. Benito, and M. J. Garde, "Single-sideband suppressed-carrier modulation using a single-electrode electrooptic modulator," *IEEE Photon. Technol. Lett.*, vol. 13, no. 8, pp. 869–871, Aug. 2001.
- [28] K. Balakier *et al.*, "Foundry fabricated photonic integrated circuit optical phase lock loop," *Opt. Exp.*, vol. 25, no. 15, pp. 16888–16897, 2017.
- [29] T. Sakamoto, T. Kawanishi, and M. Izutsu, "Widely wavelength-tunable ultra-flat frequency comb generation using conventional dual-drive Mach-Zehnder modulator," *Electron. Lett.*, vol. 43, no. 19, p. 1039, Sep. 2007.
- [30] U. Gliese *et al.*, "A wideband heterodyne optical phase-locked loop for generation of 3–18 GHz microwave carriers," *IEEE Photon. Technol. Lett.*, vol. 4, no. 8, pp. 936–938, Aug. 1992.
- [31] K. Balakier *et al.*, "Optical phase lock loop as high-Q filter for optical frequency comb line selection," in *Proc. IEEE Top. Meet. Microw. Photon.*, 2017, pp. 2–5.
- [32] F. L. Walls and A. Demarchi, "RF spectrum of a signal after frequency multiplication; measurement and comparison with a simple calculation," *IEEE Trans. Instrum. Meas.*, vol. 24, no. 3, pp. 210–217, Sep. 1975.
- [33] L. Ponnampalam, M. Fice, H. Shams, C. Renaud, and A. Seeds, "Optical comb for generation of a continuously tunable coherent THz signal from 122.5 GHz to >2.7 THz," *Opt. Lett.*, vol. 43, no. 11, pp. 2507–2510, 2018.
- [34] R. T. Ramos and A. J. Seeds, "Delay, linewidth and bandwidth limitations in optical phase-locked loop design," *Electron. Lett.*, vol. 26, no. 6, pp. 389–391, Mar. 1990.

Haymen Shams (S'09–M'12) received the M.Sc. degree from the Department of Electronic and Electrical, Alexandria University, Alexandria, Egypt, in 2006 and the Ph.D. degree in electrical and electronic engineering from Dublin City University, Dublin, Ireland, in 2011. His Ph.D. dissertation addressed the optical technologies for generation and distribution of millimetre waves and ultra-wideband RF signals in radio over fiber systems. After the Ph.D., he worked for two years as a Postdoctoral Researcher in Photonics Group in Tyndall National Institute, University College Cork. He is currently a Senior Research Associate with the Photonic Groups, Department of Electrical and Electronic Engineering, University College London, U.K. His current research interests include RF-over-fiber for wireless communication including ultra-wideband and millimeter wave signals, digital coherent receivers, digital signal processing, optical coherent THz, and spectroscopy. He has authored and coauthored more than 60 peer-reviewed journal and conference papers.

Katarzyna Balakier (M'16) received the M.Sc. degree in electronics and telecommunications with specialization in opto-electronics from Białystok University of Technology, Białystok, Poland, in 2006 and the Ph.D. degree in photonics from University College London, London, U.K. in 2016.

She worked as an R&D Engineer for LG Electronics between 2006 and 2007. In 2007, she moved to Spain where she worked on development of metrology and spectroscopy systems for space applications. In 2010, she was appointed as a Marie Curie Research Fellow with the Ultra-fast Photonics group, University College London, London, U.K., where she continues to work as a Research Associate since 2013. Her research interests include photonic integrated circuits for millimetre-wave and THz signals generation, microwave photonics, and laser's phase stabilization techniques.

Luis Gonzalez-Guerrero received the B.Sc. degree in materials engineering from the Technical University of Madrid, Madrid, Spain, in 2013 and the M.Sc. degree in photonics and optoelectronics devices from the University of St. Andrews, Scotland, U.K. and Heriot-Watt University, Scotland, U.K., in 2014. He is currently working toward the Ph.D. degree in electronic engineering from University College London in collaboration with the National Physical Laboratory. His research is focused on THz wireless communications, especially on the realization of phase noise-robust photonic THz systems for high data rate transmissions.

Martyn J. Fice (S'86–M'87) received the B.A. degree in electrical sciences and the Ph.D. degree in microelectronics from the University of Cambridge, Cambridge, U.K., in 1984 and 1989, respectively.

In 1989, he joined STC Technology Laboratories, Harlow, U.K. (later acquired by Nortel), where he was engaged for several years in the design and development of InP-based semiconductor lasers for undersea optical systems and other applications. Subsequent work at Nortel involved research into various aspects of optical communications systems and networks, including wavelength-division multiplexing, all-optical wavelength conversion, optical regeneration, and optical packet switching. In 2005, he joined the Photonics Group, Department of Electronic and Electrical Engineering, University College London, London, U.K., as a Senior Research Fellow. He is currently a Lecturer in the same department. His research interests include in millimeter and THz wave generation and detection, optical phase locking, coherent optical detection, optical transmission systems, and photonic integration.

Dr. Fice is a member of the Institution of Engineering and Technology and a Chartered Engineer.

Lalitha Ponnampalam (M'13) received the B.Eng. degree from University College London, London, U.K., in 1992, the M.S.E.E. degree from CREOL, University of Central Florida, Orlando, FL, USA, in 1998, and the Ph.D. degree from the University of Cambridge, Cambridge, U.K., in 2002. During the Ph.D. studies, she was engaged in research on the design of a novel tunable semiconductor laser. From 2001 to 2007, she was a Senior Scientist with Bookham Technology, U.K., which later became part of Oclaro, Inc. She was involved in the design and development of widely tunable semiconductor lasers and electro-absorption modulators. Since 2007, she has been with the Ultrafast Photonics Group, Department of Electronic and Electrical Engineering, University College London. Her current research interests include photonic integration, optical phase-lock loops, optical frequency comb generators, tunable laser diodes, and photonic generation of THz signals.

Dr. Ponnampalam is a member of the Institution of Engineering and Technology and a Chartered Engineer.

Chris S. Graham received the B.Eng. degree from the University of Essex, Colchester, U.K., in 2005. He joined the Ultra-Fast Photonics Group with the Department of Electronic and Electrical Engineering, UCL, London, U.K. in 2006. He researched ultrafast photonic switches for sampling applications, obtaining the Ph.D. in 2011. He has worked as a Research Associate with the Photonics Group for the last seven years working in the fields of Uni Traveling Photodiode design fabrication and evaluation; Photonic Integrated Circuit packaging, and ultrafast photoconductors. He has authored and coauthored more than 20 publications in peer-reviewed journals and international conferences, and 1 patent.

Cyril C. Renaud (M'09–SM'12) received the Engineering degree from the Ecole Supérieure d'Optique, Orsay, France, and the Diplôme d'Etudes Approfondies in optics and photonics from the University Paris XI, Orsay, France, in 1996. He spent one year as a Project Engineer with Sfm-ODS, working on the development of microchips lasers and portable range finders. He then joined the Optoelectronics Research Centre, University of Southampton, Southampton, U.K., in 1998, to work on diode pumped high-power ytterbium-doped fibre-lasers, with particular interest on Q-switched system and 980-nm generation. This work led to the award of the Ph.D. in 2001. He is currently a Reader in Photonics at University College London, and the UCL site director for the UCL/Cambridge Doctoral Training Centre in Integrated Photonic and Electronic Systems. He has authored and coauthored more than 140 publications in peer-reviewed journals and international conferences, and 3 patents.

Alwyn J. Seeds (F'97) received the B.Sc., Ph.D., and D.Sc. degrees from the University of London, London, U.K. From 1980 to 1983, he was a Staff Member with Lincoln Laboratory, Massachusetts Institute of Technology, where he worked on GaAs monolithic millimetre-wave integrated circuits for use in phased-array radar. Following three years as a Lecturer in telecommunications at Queen Mary College, University of London, he moved to University College London in 1986, where he is now a Professor of Opto-electronics and the Head of the Photonics Group. He has authored and coauthored more than 350 papers on microwave and opto-electronic devices and their systems applications. His current research interests include photonic integration, semiconductor optoelectronic devices, wireless and optical communication systems.

Dr. Seeds is a Fellow of the Royal Academy of Engineering (U.K.). He has been a Member of the Board of Governors and the Vice-President for Technical Affairs of the IEEE Photonics Society (USA). He has served on the programme committees for many international conferences. He is a co-founder of Zinwave, a manufacturer of wireless over fibre systems. He was the recipient of the Gabor Medal and Prize of the Institute of Physics in 2012 and the Distinguished Educator Award of the IEEE Microwave Theory and Techniques Society in 2018.