

Power Electronics Technology for Large-Scale Renewable Energy Generation

This article provides the latest statistics and describes the newest developments in large-scale renewable power generation.

By FREDE BLAABJERG^{id}, Fellow IEEE, YONGHENG YANG^{id}, Senior Member IEEE, KATHERINE A. KIM^{id}, Senior Member IEEE, AND JOSE RODRIGUEZ^{id}, Life Fellow IEEE

ABSTRACT | Grid integration of renewable energy (REN) requires efficient and reliable power conversion stages, particularly with an increasing demand for high controllability and flexibility seen from the grid side. Underpinned by advanced control and information technologies, power electronics converters play an essential role in large-scale REN generation. However, the use of power converters has also exposed several challenges in conventional power grids, e.g., reducing the system inertia. In this article, grid integration using power electronics is presented for large-scale REN generation. Technical issues and requirements are discussed with a special focus on grid-connected wind, solar photovoltaic, and energy storage systems. In addition, the core of the energy generation and conversion—control for individual power converters (e.g., general current control) and for the system level (e.g., coordinated operation of large-scale energy systems)—is briefly discussed. Future research perspectives are then presented, which further

advance large-scale REN generation technologies by incorporating more power electronics systems.

KEYWORDS | Control of large-scale renewable energy (REN); energy storage (ES); inverter-based resources; power converters; REN generation; solar photovoltaic (PV) systems; wind power systems.

I. INTRODUCTION

Conventional electricity generated by burning fossil-fuel energy, e.g., coal, oil, and natural gas, is not environmental-friendly and is a major contributor to climate change. Furthermore, throughout several decades of intensive exploitation of fossil-based resources, an energy crisis has been foreseen across the globe [1], [2]. However, energy consumption is still high and continues to increase as the global economy grows. It is, thus, imperative to develop and explore affordable and clean energy to enable the sustainability of the global society and to battle climate change [3]. To achieve this, many efforts have been made to expand the use of renewable energy (REN) sources [4], as shown in Fig. 1, and various REN and alternate energy technologies are still emerging. Among these REN resources, wind and solar photovoltaic (PV) is currently the most favorable, which together make up more than half of the total globally installed REN capacity. As depicted in Fig. 2, the total capacity of wind and solar energy exceeded that of hydropower in 2020, and at the end of 2021, the total renewable capacity reached more than 3000 GW, more than 2/3 of which is from wind and solar generation. It can be anticipated that more wind and solar PV capacity will be installed soon, as the cost of such technologies is still declining [5]; hence, large-scale wind and solar PV power generation is right around the corner.

Manuscript received 21 May 2022; revised 5 December 2022 and 26 January 2023; accepted 1 March 2023. Date of publication 14 March 2023; date of current version 5 April 2023. This work was supported in part by the Reliable Power Electronics-Based Power Systems (REPEPS) Project from The VELUX Foundations through the Villum Investigator Program under Award 00016591, in part by the National Natural Science Foundation of China under Project 52107212 and in part by the Zhejiang Kunpeng Investigator Program, in part by the Taiwan Ministry of Science and Technology under Grant 109-2218-E-002-011-MY3, and in part by the Chilean National Agency for Research and Development (ANID) under Project FB0008, Project ACT192013, and Project 1210208. (Corresponding author: Yongheng Yang.)

Frede Blaabjerg is with AAU Energy, Aalborg University, 9220 Aalborg, Denmark (e-mail: fbl@energy.aau.dk).

Yongheng Yang is with the College of Electrical Engineering, Zhejiang University, Hangzhou 310027, China (e-mail: yang_yh@zju.edu.cn).

Katherine A. Kim is with the Department of Electrical Engineering, National Taiwan University, Taipei 106, Taiwan (e-mail: katherine.kim@ieee.org).

Jose Rodriguez is with the Faculty of Engineering, Universidad San Sebastian, Santiago 8420524, Chile (e-mail: jose.rodriguez@uss.cl).

Digital Object Identifier 10.1109/JPROC.2023.3253165

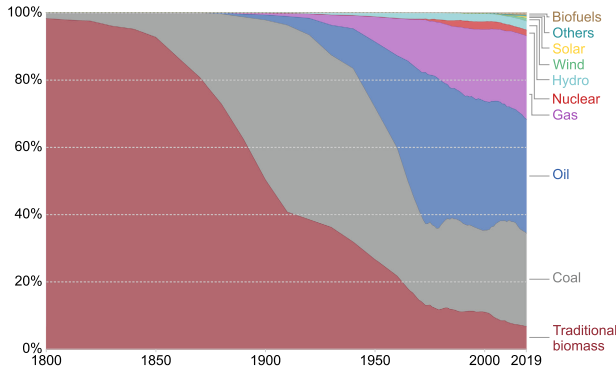

Fig. 1. Global direct primary energy consumption (relative) in the past two centuries, where the inefficiencies in fossil fuel production are not considered [4]. It shows that the dependence on fossil fuels is declining, but it is still high, e.g., in 2019.

It is well known that the use of REN resources for electricity generation is different from conventional fossil fuels. More specifically, conventional power generation uses synchronous generators (SGs) (using steam-based turbines), referred to as large-scale power plants, which govern the frequency and voltage of the grid. In this case, the generation capacity is sized to meet the predicted demand, and it is directly dispatchable so that the generation and demand can easily be balanced. Conversely, REN generation is highly intermittent such that the power generation from individual REN systems is nondispatchable and difficult to predict. With the integration of large-scale REN resources, the balance between generation and demand is still a challenge to maintain [6], [7], [8], [9]; hence,

power system-wide strategies should be developed to manage the variable generation from multiple REN systems connected to the same grid. Moreover, controlling and conditioning the power generated from REN resources are achieved using (nonlinear) power electronics (power switching devices). It is, thus, expected that, as more REN power generation is deployed, the power electronics that control them will make up a larger portion of the grid. Fig. 3 exemplifies the use of power electronics in modern power transmission systems while also looking toward 100% power electronic-based power systems [7], [10], [11], [12], [13]. In this context, the large-scale adoption of power electronics for REN resources, being inverter-based, is making the utility grid more complicated, even to a point where the stability might be challenged [14], [15], [16], [17], [18]. On the other hand, with the advancements of power semiconductor devices (e.g., high-voltage blocking capability and high efficiency), the power converters, as the core of energy conversion from REN resources to electricity, provide more controllability and flexibility; however, the design and control should still be further advanced [19], [20], [21], [22], [23], [24] toward systems that are more intelligent, lower cost, and more efficient. At the same time, the design and control of the employed power converters should be more open and/or standardized to address the challenge of modeling “black boxes” from different manufacturers that are often proprietary to the companies.

In addition, the operation of large-scale REN systems is mostly in harsh environments (e.g., offshore wind systems under high humidity). This imposes intense thermal loading on the power converters and challenges the reliability of the entire generation system. Reliability is an important index as REN systems are long-term investments that are often costly to repair. By improving the reliability, the overall cost of REN resources can be (further) reduced, leading to higher competitiveness for the REN resources. Hence, many solutions for reliability, robustness, and resilience enhancements of inverter-based REN resources are emerging [25], [26], [27], [28]. For instance, the design for reliability based on the physics of failures can improve the reliability of individual power converters [25] and, in turn, the entire system. At the same time, the harsh operating environments for the REN systems can potentially induce large disturbances, which the power converters have to withstand. To guide the grid integration of REN resources, transmission system operators (TSOs) and/or distribution system operators (DSOs), together with other stakeholders or entities, have issued stringent interconnection requirements and grid codes [14], [15] for the commissioning and operation of large-scale REN power systems. Taking the IEEE Std. 1547a-2020 [29] as an example, it is required that the distributed energy resources have to respond to abnormal voltages and ride-through of the disturbances properly. Relevant standards/grid codes can harmonize the work done by different entities to further increase the penetration of REN resources for a cleaner energy society.

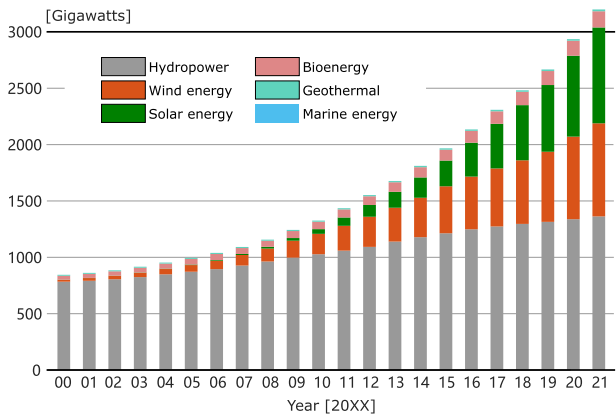

Fig. 2. Global accumulative capacity of REN from 2000 to 2021 based on the data available from IRENA and the data represents the maximum net generating capacity of power plants and other installations using REN sources to produce electricity [1], where hydropower includes pumped storage and mixed plants; marine energy covers tide, wave, and ocean energy; solar energy includes solar PV and concentrated solar power; and wind energy covers onshore and offshore wind. As indicated, the sum of wind and solar capacity has exceeded the total hydropower capability in 2020. Some data (from 2000 to 2011) are from previous reports (<https://www.irena.org/publications/>).

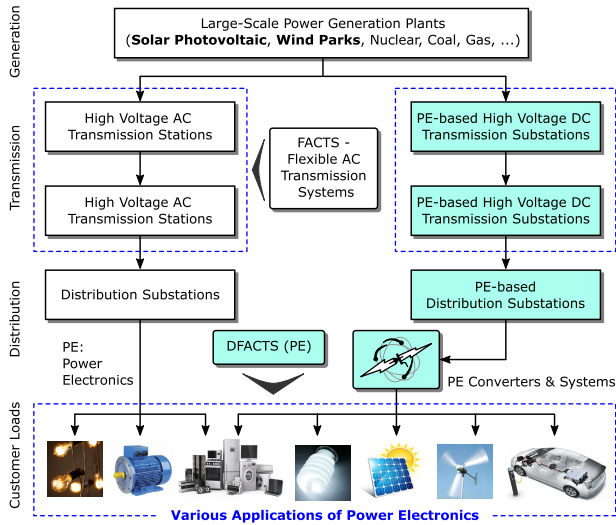

Fig. 3. Power electronics in modern power transmission systems and its increasing applications in future energy systems (DFACTS—distributed flexible ac transmission system), which is anticipated to be more used. Notably, power electronics are more intensively used to process electrical energy in the right five kinds of applications (appliances, LED lighting, solar PV, wind, and electric vehicles) compared to the left three.

In other words, they can be used as the main design and planning benchmarks for large-scale REN power generation. In all, the measures that should be taken to improve the integration of large-scale REN systems are related to the design, control, and operation of power electronic converters.

Furthermore, to enhance the grid integration of large-scale REN systems, the operation of inverter-based resources can be improved by integrating large-scale energy storage (ES). That is, the development of advanced ES technologies is important [30], [31], [32], [33]. ES systems can be a buffer to balance and/or ease the management of the variable power generation from REN resources and the load demands. However, currently, large-scale ES systems are still highly costly, except for the geography-limited pumped storage hydropower systems. Seen from the multifold benefits brought by ES systems, more ES will soon be seen in practice, as an essential asset to enhance the grid integration of REN resources. Notably, power electronics (interlinking the REN resources, ES systems, and the grid or local loads) will again play a vital role in large-scale ES systems and in transforming energy paradigms. In particular, the coordinated operation can be achieved in a cost-effective way [33], [34], [35], especially with the aid of artificial intelligence (AI) [36], to improve the economic performance of the entire system. The integration of ES is seen as a system-level solution to the performance enhancement of large-scale REN systems.

With the above, the challenges, solutions, and opportunities for large-scale REN generation are discussed in this article, focusing on power electronics and advanced control. Compared to the existing survey papers and textbooks, this article considers the most widely used REN

sources, i.e., wind and solar PV energy, while considering ES (mainly, battery storage). A comprehensive review of key technologies for REN is provided, and the corresponding technology development prediction is also discussed. Although this is a broad review article, it primarily focuses on wind, solar PV, and ES technologies seen from the power electronics perspective, as a timely summary of the key technologies for large-scale REN generation. The rest of this article is organized as follows. General requirements and demands for the grid integration of REN resources are presented in Section II. Advances in power electronics for wind, solar PV, and ES are overviewed in Section III, where power electronics for modern transmission systems is also discussed. Control techniques and system-level operation strategies for large-scale REN generation are briefly presented in Section IV, followed by challenges and future research perspectives in large-scale REN systems in Section V. Finally, concluding remarks are given in Section VI.

II. REQUIREMENTS AND DEMANDS OF RENEWABLE ENERGY GENERATION

As pointed out in Section I, large-scale REN generation is different from conventional power generation systems. When integrating into the grid, various requirements and/or demands must be complied with at different layers. In this section, the requirements and demands of large-scale REN systems are presented, including those for wind and solar PV systems (generator side), ES, and grid connection (grid side). The role of power electronics is highlighted.

A. Requirements of Wind and PV Generation Systems

As shown in Fig. 4, the wind and PV generation systems can be divided into generation and conversion stages.

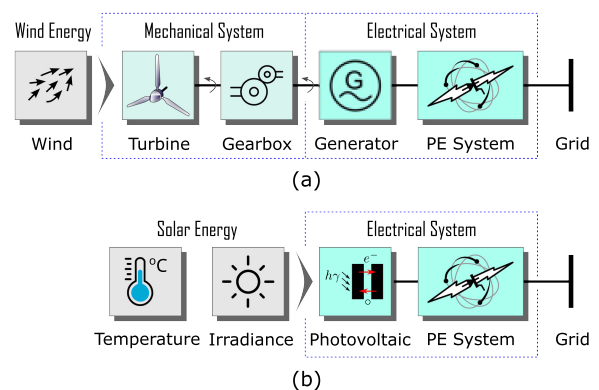

Fig. 4. General configuration of (a) wind power generation system (in some cases, the gearbox is optional) and (b) PV power generation system, where the PE system is the power electronics system, including power converters and the associated control. Here, the PV power generation system is based on the photovoltaic effect.

More specifically, wind energy is captured through the mechanical system (including turbines), and ac electricity is generated. For solar PV systems, the energy is collected through many PV cells that statically convert the solar energy from sunlight based on the *photovoltaic effect* into dc electricity. Solar PV energy can also be collected through PV cells with a solar concentrator. In this article, we consider PV technology only. To comply with load characteristics at the point of common coupling (PCC), e.g., an ac grid, power electronics is used as the intermediate stage to condition the electricity generated from wind turbines (WTs) or solar PV cells. Dedicated strategies are implemented in the control of power converters for individual systems to better integrate the REN resources with the load (e.g., utility power grids). Requirements of wind and solar PV generation systems are summarized in Fig. 5, which indicates that different demands are imposed on the generation and conversion stages.

For WT systems, the electromagnetic torque is controlled by regulating the generator-side current that flows in the generator rotor or stator. By doing so, the power extracted from the WT can be optimized; this is a type of control known as maximum power point tracking (MPPT), which can be achieved by regulating the blade rotational velocity and pitch angle as well [37], [38]. In other words, it is to achieve an energy balance between the mechanical and electrical power conversion in the WT. As shown in Fig. 5, WT power generation systems also need to control the generator frequency. At present, for both WT and PV systems, the status of the generators (e.g., the turbines and the PV cells) should be monitored to enable timely maintenance or detect abnormalities. This can be further enhanced by AI technologies [39], [40], [41]. Moreover, either the voltage or the current (or both) should be controlled on the generator side.

Due to the increasing capacity of an individual WT or solar PV array, many power semiconductors are used to assemble the power stage. Efficiency and power density are major considerations. For instance, for offshore WT systems, higher power density means lower installation costs, which further helps to reduce the cost of wind energy. Advanced wide bandgap (WBG) devices bring

many opportunities to improve efficiency and power density [42]. Yet, power semiconductors may fail to operate due to sudden disturbances (e.g., short-circuit faults) or long-term fatigue. When this occurs, the shutdown of the power conversion system may be inevitable, which may challenge the entire grid stability, leading to huge economic losses and increased maintenance costs. Hence, power converters should have high reliability, which can be achieved through effective design and control for reliability [25]. Alternatively, reliability and power density can be enhanced by better managing the thermal flow to reduce peak temperatures in the power electronic converters, as high temperatures accelerate component degradation [25]. This is especially important for WT systems, where power converters are installed in the housing, called a nacelle, with limited space for heat dissipation. That is, cooling systems and thermal management should be properly designed. Communication and status monitoring of power converters are increasingly required so that the performance of wind and PV power systems can be enhanced (e.g., reliability and efficiency improvement). In addition, the operation of large-scale systems can be coordinated via communication [21]. This also helps to optimally dispatch the power flow.

As can be seen in Fig. 5, control of power converters is of importance. It helps the entire REN power generation system to meet different demands, i.e., to make it multifunctional [9]. The above indices (e.g., reliability, efficiency, and MPPT) can be improved through the control of power converters. There have been many control technologies for PV and wind power systems developed in the literature [24], [43], [44], [45]. Among those, linear controllers, such as a proportional–integral (PI) controller, are the most widely used in practice, while nonlinear control, such as model predictive control (MPC) [45], is also being advanced and implemented in recent years. Developments in information technologies are transforming the control capabilities of power converters. For example, AI-aided control has been used in power converters to improve their reliability and stability [46]. In all, the control acts as the brain of REN systems to meet various requirements. Underpinned by communication, control is essential to the coordinated operation of large-scale REN systems.

Finally, the voltage level of individual wind or PV generators is still low compared to the voltage at the PCC. The low output voltage may need to be increased to facilitate power transmission. In other words, step-up transformers are typically adopted at the medium-voltage (MV) side. This imposes additional challenges on the power converters in terms of power converters topologies, passive filter design and integration, and control, especially with the increasing adoption of WBG devices [e.g., silicon-carbide (SiC) devices] for efficiency improvements. At the same time, it also provides opportunities to develop new technologies, e.g., solid-state transformers (SSTs) and substations [47], [48].

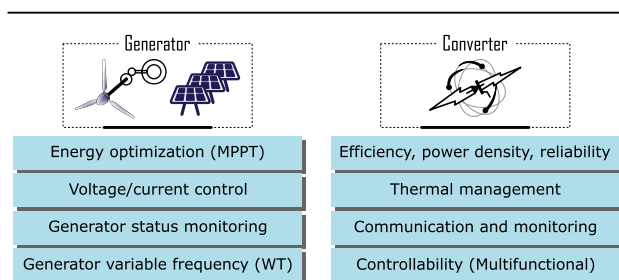

Fig. 5. Common requirements of individual wind and solar PV power generation systems (generator and converter), where MPPT represents the maximum power point tracking and WT stands for the wind turbine.

B. Requirements of Energy Storage Systems

In order to balance the ambient-condition-dependent power production (e.g., weather and time of day) from REN resources and varying consumption, ES is necessary. To enable the increasing penetration of REN power generation systems onto the grid, ES is an asset for grid regulation with many benefits [49], [50], [51]:

- 1) Conventional power generation systems can be operated in an efficient and conventional way since the fluctuating power due to the intermittency of REN resources is mitigated by charging and discharging the ES units.
- 2) Power generation from the REN resources can be flexibly stored in ES units, and it can be used to improve the utilization and optimize the power flow, further reducing the need for processing peak power or transmission of large power capacity in short periods.
- 3) Emergency handling capability of the utility grid can be enhanced by ES units, where critical operation demands can be achieved, e.g., black starts.

In addition, the integration of ES systems helps to achieve a more stable electricity price. In all, the ES becomes more important for the energy transition to meet the need for a more efficient and sustainable energy system.

Thus, many ES technologies (e.g., pumped storage, Li-ion batteries, flow batteries, flywheels, and hydrogen-based systems) are being developed. Their characteristics differ, and thus, the corresponding control strategies are important, when being implemented in grid-scale systems. For example, a pumped-hydro station is suitable for bulky load management applications due to its large energy and power capacities, while it is limited by its physical location. Moreover, one concern of the chemical-based ES systems is safety (risk of fire due to thermal runaway under unbalancing voltages among cells during operation) that can be enhanced by advanced energy management systems (EMSs). A qualitative comparison of the characteristics of selected ES technologies is given in Table 1. More detailed benchmarks can be found in [52], [53], [54], [55], and [56].

C. Interconnection and Integration Requirements

Power electronic converters should be multifunctional to enable the integration of REN systems. Different demands can be met through the control of power converters. Among those, power quality is the foremost issue. For instance, as defined in the IEEE Std. 1547-2018, the total harmonic distortion (THD) of PV systems should be below 5%. There are two reasons for large harmonic emissions: the inherent intermittency leading to power fluctuations and the continuous use of nonlinear power converters. When developing REN systems, harmonic interference and interaction issues should be explored, which are strongly related to: 1) topologies and 2) controllers. Power converters with WBG devices for REN applications

Table 1 Comparison of Selected ES Technologies [52], [53], [54], [55], [56]

ES Tech.	Pumped Hydro	Flywheel	Li-ion Battery	Flow Battery	Super Capacitor
Type	AC	AC	DC	DC	DC
Power Range	Up to several GWs	Up to a few tens MWs	A few kW to several tens MWs	Up to several MWs	Up to a few MWs
Dis. Time	Many hours	Several minutes	Several hours	Several hours	Up to an hour
Response	Slow	Very fast	Fast	Very fast	Very fast
Costs	Lowest	Very high	Low	Medium	Very high

Notes: Tech. – Technology; Dis. – Discharging
GW – Gigawatt; MW – Megawatt; kW – Kilowatt

switching at a high frequency of up to a few hundreds of kHz may complicate the harmonic contents; harmonics from interconnected converters can interact with each other, possibly leading to resonance and instabilities. This requires the power converter to withstand severe conditions [e.g., unfavorable harmonic content and electromagnetic interference (EMI)].

To integrate more power electronic-based REN systems into the grid, it may become necessary for power converters to emulate the behaviors of conventional power plants irrespective of the operating states. This is beneficial to allow for stable operation even with the cut-in and cut-out of multiple generation units and the dynamic operation of the entire multiconverter REN systems. It is a means for power converters to effectively maintain the frequency and the voltage amplitude of the grid. Next-generation REN systems are required to actively participate in grid regulation [14], [15]. This is a measure to maintain robustness in response to various disturbances apart from harmonics. For example, to ensure the safety of equipment

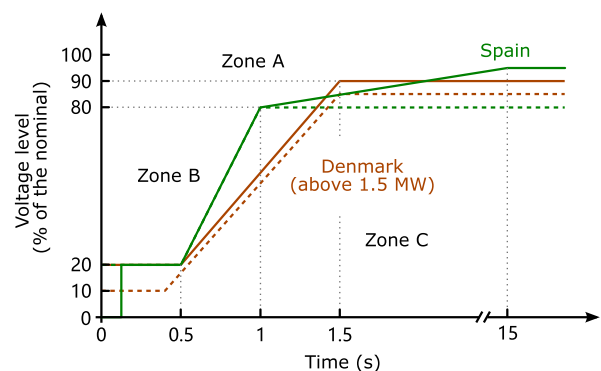

Fig. 6. LV ride-through requirements (voltage profile) for wind (solid lines) and PV (dashed lines) power generation systems in Spain and Denmark [2]. Above the curves, Zone A and Zone B, the systems should remain connected; below the curves, it is allowed to disconnect the generation systems from the utility grid.

connected to the PCC, PV systems must have islanding detection and protection. Under grid faults (e.g., voltage sags), both wind and PV power generation systems should not only withstand temporary grid faults but also contribute to grid voltage recovery [2], [4]. Fig. 6 exemplifies the low-voltage (LV) ride-through requirements of REN generation systems. Other protection schemes and strategies should be developed to ensure safe power generation from REN resources and its operation [2], [14], [15].

Beyond the above issues, as more SGs are being phased out and replaced by power electronic-based REN systems, power converters may interact with each other [14], and additional functionality may be required. For instance, more and more grid operators demand wind and PV power systems to provide power oscillation damping and black start capabilities [56]. This will also enhance the transient stability and performance of large-scale REN generation systems, but, at the same time, the control strategies are becoming more advanced. In all, in terms of interconnection and integration, large-scale REN power generation systems are becoming multifunctional, both statically and dynamically, to maintain the robustness and resiliency of the entire power grid.

III. POWER ELECTRONICS FOR WIND, PV, AND ENERGY STORAGE SYSTEMS

Power electronics plays an important role in the expansion of large-scale REN generation systems. In this section, the development of power electronics and converters is presented, followed by a detailed discussion of the power configuration architectures for wind, PV, and ES systems.

In addition, power electronics technologies for transmission systems are discussed.

A. Power Electronics Development and General Converters

The history of power electronics goes back more than 100 years [57], as shown in Fig. 7. Since the invention of the mercury arc rectifier, power converters have been adopted to deal with the electrical conversion and control of electrical power, especially after thyristors were invented in the 1950s. Since then, with the 65 years of development of power semiconductors, power electronics technology has been evolving, as presented in Fig. 7, from the basic search of topologies, control techniques, and efficiency to application-oriented technological improvements, such as packaging, thermal management, and modularity. In other words, power electronics development was initially function-/mission-driven but has shifted to be more performance-driven. Along with this, information and communication technologies (ICTs) have been increasingly used in power electronics converters. Advancements in power electronics lay the foundation for the fast and effective use of REN generation systems.

In practice, as discussed in Section II, power electronics should achieve low losses, high reliability, and high-power density (e.g., using high switching frequencies). Accordingly, many power converter topologies have been proposed in the literature and used in industrial applications. Among those, two- and three-level converters are the most used and commercialized topologies. Fig. 8 shows two- and three-level neutral-point clamped inverters that are voltage-source converters (VSCs). The multilevel technology, e.g., the three-level converter, is an effective method to

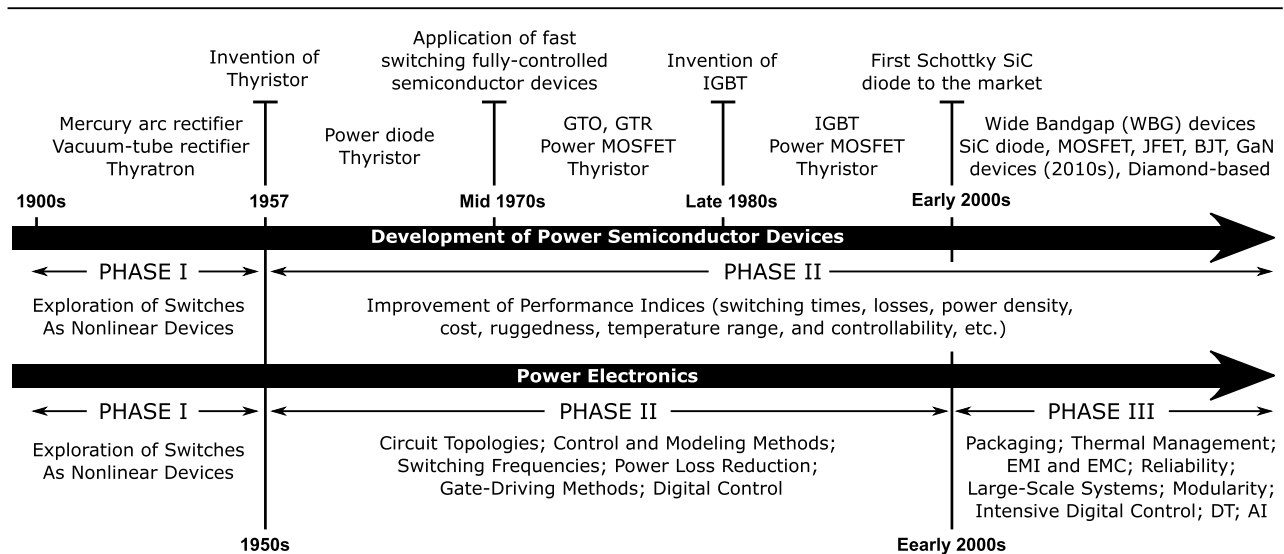

Fig. 7. Advancements in power electronics along with the evolution of power semiconductor devices technologies [57], being one of the major reasons for the fast development of REN power generation systems. Here, GTO: gate turn-off thyristor; GTR: giant transistor; MOSFET: metal-oxide-semiconductor field-effect transistor; IGBT: insulated-gate bipolar transistor; SiC: silicon carbide; GaN: gallium nitride; EMI: electromagnetic interference; EMC: electromagnetic compatibility; DT: digital twin; and AI: artificial intelligence.

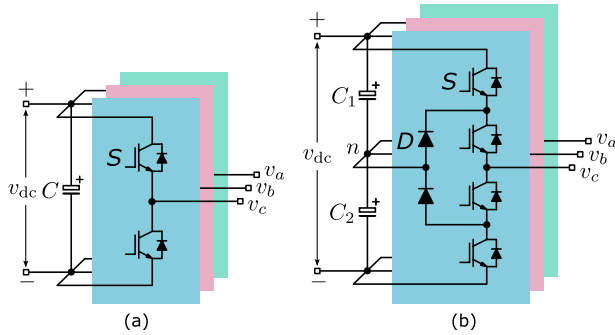

Fig. 8. General power converters for REN systems: (a) two-level inverter and (b) three-level neutral-point clamped inverter, which can be used to build up large-scale REN generation systems. Here, v_{dc} is the dc-link voltage; C , C_1 , and C_2 are the dc-link capacitors; S represents an IGBT with a parallel diode; D indicates a diode; and $v_{a,b,c}$ are the output voltages.

address limited voltage ratings of power devices, especially for large-scale REN generation systems. It can also help to reduce the filtering required at the output (e.g., using smaller and simpler filters but achieving a high power quality). Modular multilevel converters (MMCs) are a representative type that has been commercially used in high-voltage transmission systems. In addition to VSCs, current-source converters (CSCs) are seen in MV motor drive applications due to their strong fault-current withstanding capability. To assemble large-scale REN generation systems, many general converters, such as those shown in Fig. 8, can be used to handle higher power levels and currents. Moreover, the concept of power electronics building blocks [59] has become a general solution for power electronics development to scale up power.

B. Conversion Architecture for Large-Scale Wind Systems

Benefitting from the advancements of power semiconductor and power electronics technologies, wind power systems have been through a substantial technological transformation over the past several decades. This is also driven by the need for lowering the cost of energy. In the 1980s, a WT system of 50 kW was considered large, where power electronics was barely utilized. Compared to the WT systems in today's markets, where a WT power rating is typically at 2–3 MW, the 50-kW power level is relatively low. Now, the rating of a single WT system is approaching 15 MW [19], [60], as indicated in Fig. 9. It is, thus, becoming uneconomically viable to directly process such a large amount of power without power electronics. As shown in Fig. 9, along with the increasing power capacity of a single WT, the utilization of power electronics is also increasing. At the same time, the functions of power converters are changing, e.g., from a single function (like soft start) to multitasking operation, as WT power systems are considered active contributors and stabilizers in the overall power grid. In terms of generator technologies,

Table 2 Generator Technologies for WT Power Systems

Manufacturer	Generator Technology	Rotor Diameter (m)	Power Range (MW)
Vestas	DFIG	90 – 120	2.0 – 2.2
	PMSG	105 – 236	3.4 – 15*
Siemens Gamesa	PMSG	193 – 222	10 – 14*
	SCIG	154 – 167	6.0 – 8.0
	PMSG	120 – 142	3.5 – 4.3
	DFIG	114 – 145	2.1 – 4.5
Goldwind	PMSG	93 – 175	2.0 – 8.0
GE	DFIG	116 – 158	2.0 – 5.3
	PMSG	151, 220	6.0, 12
Envision	DFIG	82 – 148	2.0 – 4.5

Notes: DFIG – Doubly-fed induction generator; PMSG – Permanent magnet synchronous generator; SCIG – Squirrel-cage induction generator.
* Estimated serial production in 2024 [60], [61].

most of such systems were designed based on the doubly fed induction generators (DFIGs) (shared a larger portion of the market in the past). In this case, power electronics was partially used, i.e., only the rotor employed a power electronics converter with a reduced rating. To flexibly process the increasing power of the WTs, full-scale power converters were then increasingly used with induction, permanent magnet, and wound-field SGs, also due to the continuous cost reduction of power electronics. Table 2 summarizes the generator technologies from various WT manufacturers.

For large-scale wind power generation systems, the energy conversion should be as efficient as possible to further lower the cost of energy. This is also seen in the increasing utilization of power electronics in individual WT systems, as aforementioned (see Fig. 9). On the other hand, REN power generation should be more active in grid regulation, and it is required to comply with stringent grid codes, which have been presented in Section II and will be further discussed in Section III. Hence, the design and configurations of large-scale WT power systems, which involve a very large-scale adoption of power converters, are of importance. A better system configuration can contribute to high efficiency and easier compliance with grid requirements.

Many solutions have been proposed in the literature [19], [62] to integrate large-scale wind energy into the grid. Among those, most wind farms are currently connected to the grid via medium-voltage ac (MVac) technology, as shown in Fig. 10. Both DFIG and permanent magnet SG (PMSG)-based WTs can be used, as exemplified in Fig. 10. Such a wind farm can easily have an accumulative power capacity of a few hundred megawatts, e.g., the Anholt offshore wind farm of 400 MW in operation in Denmark. It should be noted that power converters for the individual WT in such wind farms have to comply with and meet the demands outlined in Section II. More importantly, at the system level, additional measures may be taken to enhance grid integration. For instance, due to the limited reactive power capability, a centralized

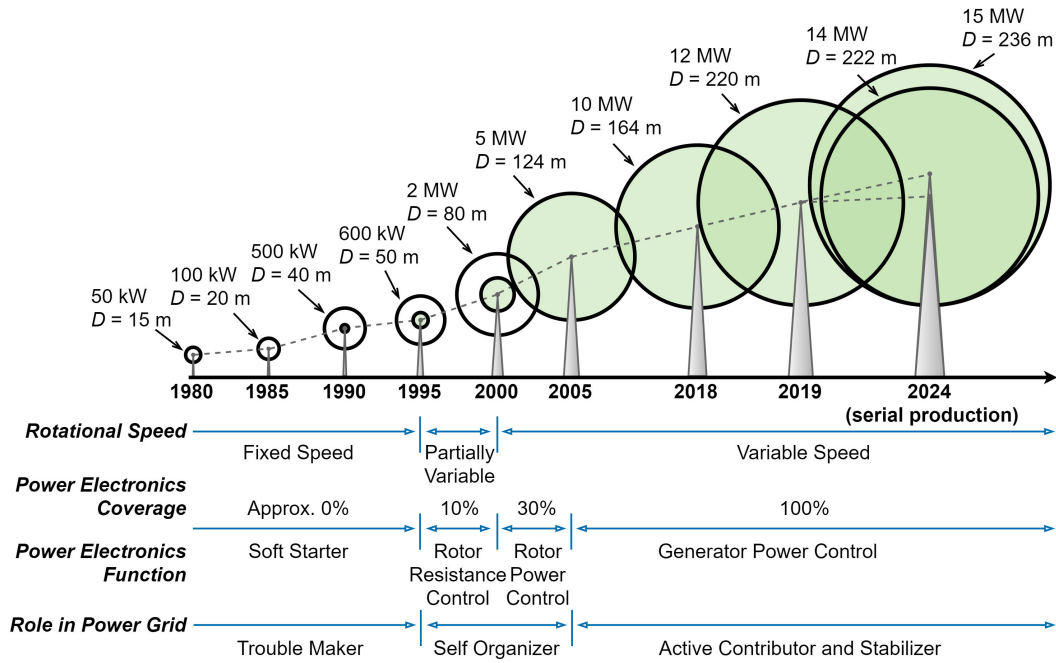

Fig. 9. Development of WT technologies, where “green area” indicates that the use of power electronics has been increasing significantly to process a large amount of power from WT systems. Here, D represents the diameter of the WT rotor; MW stands for megawatts.

reactive power compensation unit like a static synchronous compensator (STATCOM) may be installed to meet grid requirements, as shown in Fig. 10(a). By contrast, reactive power capability can be enhanced, especially when full-scale power electronics are adopted to assemble large-scale

wind farms [see Fig. 10(b)]. In this, the generators can be PMSGs with full-scale power converters. Due to the ever-increasing need for flexibility and controllability of reactive power, the grid-side converter in each individual WT system can provide the required reactive power upon demand. As a result, additional reactive power compensators may be avoided, while, at the same time, the collector network should be properly considered. Notably, the individual power converters should be properly designed by following the requirements presented in Section II.

With respect to long-distance power transmission, which is common in wind farms (e.g., from an offshore wind farm to the grid), high-voltage dc (HVdc) transmission technology has been developed and implemented in recent years. HVdc transmission is an important option, as it can achieve a high transmission efficiency, and there is no reactive power during power transmission [58], [62]. In addition, HVdc technologies are used in wind applications, while high capacitance (due to longer cables) makes reactive power management very difficult if ac cables are adopted. For large-scale WT power systems, HVdc transmission can be achieved through various configurations, as shown in Fig. 11. For example, the MVac voltage of the wind farm output can be converted to HVdc by a boosting transformer and high-voltage source rectifiers to achieve dc power transmission, as observed in Fig. 11(a). Alternatively, HVdc transmission can be attained by employing fully active-controllable power converters, e.g., SSTs, as presented in Fig. 11(b). In this case, the LV/MV of the WTs is converted to a medium/high dc voltage for transmission. In this configuration, a full dc power delivery in both the distribution and transmission lines can be realized and, thus,

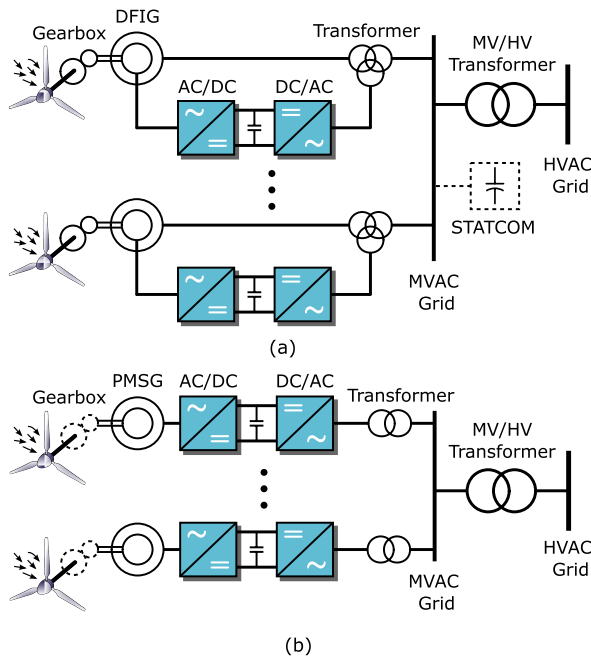

Fig. 10. Configurations of large-scale WT power systems connected to MVac grids: (a) DFIG-based wind farms and (b) PMSG-based wind farms, where the MVac grids are connected to the HVac grid through MV/HV transformers. Here, the voltage level of MVac grids is 11–33/34.5/46 kV while 60–245 kV for the HVac grid.

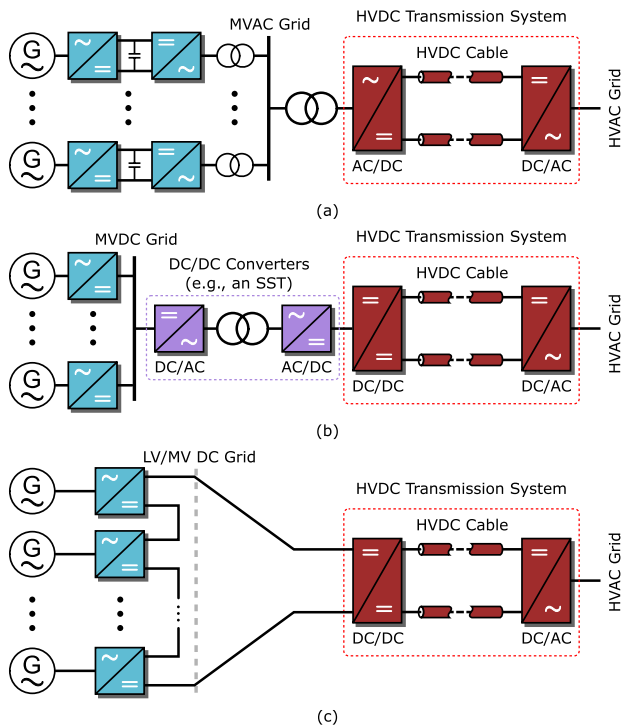

Fig. 11. Configurations of large-scale WT power systems with HVdc power transmission: (a) full-scale converters with VSC rectifiers, (b) full-scale converters enabling both distribution and transmission dc grids, where the dc/dc station of the HVdc transmission system is optional, and (c) cascaded power converter structure. Here, G is the WT generator. SST: solid-state transformer. LV/MV: low voltage/medium voltage.

improve the overall efficiency of the power delivery and transmission [62], compared to the solution in Fig. 11(a). This is attributed to the removal of several power converter and transformer stages. What is more, SSTs (dc–dc power transformers) enable flexible power flow management in smart grids. In addition, another solution to power transmission is based on the cascaded structure, as shown in Fig. 11(c), whose control is more complicated than others to balance the power between each module and optimize the energy flow. Notably, considering the overall cost and limited space of offshore platforms, the active rectifiers using full-controllable power devices [e.g., insulated-gate bipolar transistors (IGBTs)] are not specifically feasible. Instead, multiple diode rectifiers can be employed to replace the VSC-based rectifier in the HVdc transmission system of Fig. 11(a). With this solution, a reduction of power losses and weight can be achieved for several-hundred-MW HVdc systems. Additional benefits, such as scalability, redundancy, and reliability, make this solution very cost-effective, while the controllability must be maintained at the LV or MV sides.

C. Conversion Architecture for Large-Scale PV Systems

Compared to wind power systems, PV systems consist of a considerable number of solar PV cells/panels that

are connected in series and in parallel, as discussed in Section II. The power level per panel of many solar PV cells is approaching 600–700 W [63], which is, however, still far lower than the capacity of an individual WT. For large-scale PV power systems, many series-connected PV panels (forming as PV strings) and then many PV strings in parallel (as arrays; see Fig. 12) are used for higher power generation. In such applications, inverters connected to a single PV string or multiple strings are called string inverters, and for converters interfacing PV arrays (i.e., many PV panels connected in series and in parallel), those are called central inverters. Both technologies are widely adopted in practice. Notably, the converter topologies can be the same for string and central inverters, e.g., the two- and three-level inverters shown in Fig. 8, while the power device ratings are usually different.

In addition, a large amount of PV arrays can occupy considerable land space, and thus, large-scale PV power plants are usually installed in areas with large open spaces. Nonetheless, among the top in-operation PV plants, the central inverter technology (several central inverters) is the most widely adopted approach for such applications, as it is the simplest way to collect dc power from PV arrays with a low construction cost. In turn, it contributes to the reduction of the PV plant cost per watt of the nominal power, i.e., the cost of PV energy. In practice, multiple string inverters have also been used to maintain energy supply reliability. Fig. 12 shows the general configurations of large-scale PV power generation systems connected to the MV/high-voltage ac (HVac) grids, where single converters are exemplified.

It is worth noting that, for the central inverters with many PV panels connected in series and in parallel, which are typically installed in a large area, the MPPT efficiency is often low. This is because the PV panels spread over a large area may receive nonuniform irradiance (leading to mismatching characteristics that reduce power generation) compared to the string inverters installed in a smaller area, where each panel receives almost the same solar irradiance. On the other hand, as central inverters have fewer power conversion stages, the overall conversion efficiency is still generally higher than 95% [12]. This is also another reason for large-scale PV generation systems to be installed in large open spaces (avoiding mismatched panel characteristics due to shadowing from buildings or trees) to increase the harvested energy. In practice, to address this and, thus, to further optimize the energy yield, many PV strings are connected to a single converter to ensure that the energy is supplied reliably, where a dc combiner box is adopted like the one shown in Fig. 12. Moreover, practical projects also employ several power converters to alleviate the power mismatching impact (e.g., aging of panels and risk of heat damage) and maintain the power supply in the case of PV string faults. In addition, the use of multiple power converters is due to the limited power ratings of the power semiconductor devices. Again, multilevel converters are gaining popularity in high-power PV systems,

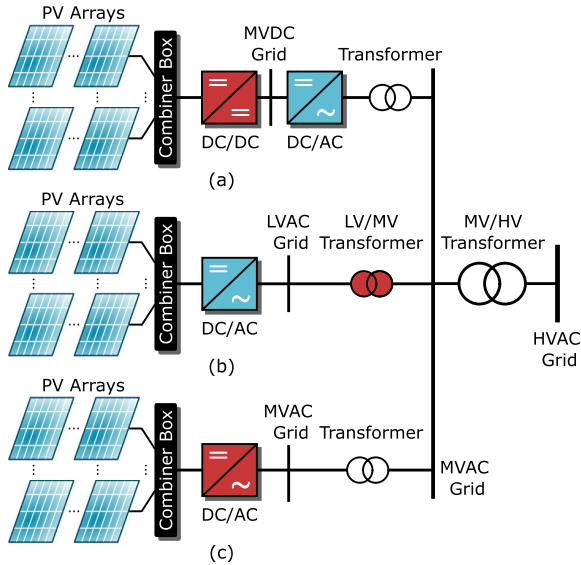

Fig. 12. Typical configurations of large-scale PV power generation systems connected to MVac grids: (a) double-stage via a boosting dc/dc converter, (b) single-stage using a boosting transformer, and (c) single-stage through a step-up inverter. Here, cascaded structures can also be used. The red dc/ac in Fig. 12(c) means that the inverter has boosting capability.

as discussed in Section III-A. The typical power rating of central PV inverters is several hundred kilowatts, while commercial central power inverters of several megawatts are also emerging and have become available in recent projects.

Furthermore, as seen in Fig. 12, many PV arrays are connected to combiner boxes using dc wires, which can incur a considerable ohmic loss in practice for large-scale PV power generation systems. Also, dc wires to carry large currents are difficult to bend in practical installations. To address these issues, the maximum dc voltage for PV power converters has been shifted from 1000 to 1500 V, especially in utility-scale systems [12], [64], [65]. Beyond the dc wire loss reduction, the 1500-V technology also brings several other benefits: reduced cable costs (as well as the overall system cost), increased reliability (fewer combiner boxes), and lowered installation investment. In turn, it brings more energy production and lowers the cost of energy. Fig. 13 shows an example of an MV utility-scale PV power generation system based on the 1500-V technologies and SSTs, which can further increase the system efficiency, power density, and controllability (e.g., providing grid support). Notably, referring to the demands presented in Section II, the PV power converters have to meet various requirements. Furthermore, the requirement of thermal management is one even in applications of high efficiency, and modular multilevel technologies [57], [68] enable the generation being of high power quality, as well as higher reliability due to the increased redundancy and scalability (many modules in use).

At the same time, the 1500-V technologies have several challenges. For example, due to the series connection of many PV panels needed to achieve the 1500-V dc voltage, potential-induced degradation [69] (e.g., power generation and efficiency may be lower) may become more severe, which also poses electric safety concerns. Moreover, the converters previously designed for 1000-V applications have to be redesigned to accommodate the higher dc voltage. To achieve this, advanced power devices can be adopted, or topological innovations should be considered. In all, considering the significant cost reduction and energy increase, the 1500-V technologies are now standardized. As aforementioned, the use of multiple 1500-V converters for large-scale PV systems is common, and more will be seen. The accumulative power capacity of a single PV plant may challenge the entire grid operation and cause instabilities. In this regard, like the demand for large-scale WT power systems, advanced control is of importance to ensure the seamless integration of large-scale PV systems, which will be discussed in Section IV. In terms of power transmission, HVdc technology can be adopted, but it is not common as the location of large-scale PV power systems is relatively close to the load.

D. Integration Architecture for Energy Storage Systems

As it has been discussed in Section II, with the increased penetration of REN resources, the role of ES devices has become much more important in the energy transition. Notably, ES technologies are not something completely new, and various applications of ES devices and systems have been seen in practice, ranging from small electronics to automotive applications to utility-scale grid systems. It should be pointed out that, in all the listed applications, power electronics provides essential interfaces between the storage units and loads. Although there are many types of ES systems, this section gives an overview of the power

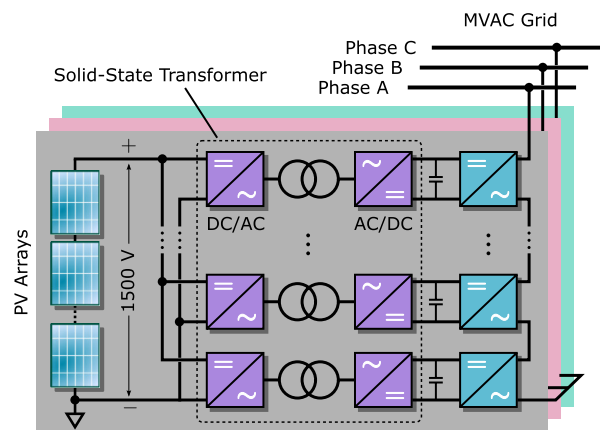

Fig. 13. Example of utility-scale PV power generation based on 1500-V technologies, where SSTs are adopted, increasing the controllability of the overall system.

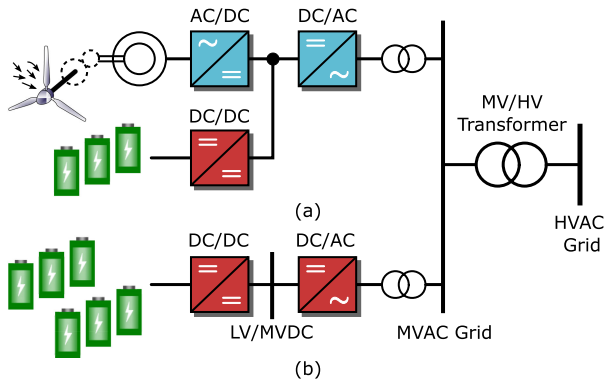

Fig. 14. ES integration architectures: (a) dc-coupling configuration as distributed solutions, exemplified on a wind power generation system and (b) ac-coupling configuration, as a centralized ES system, where dc/dc converters are optional, and multiple dc/dc converters can also be adapted to connect batteries to an MVDC grid.

electronics architectures of large-scale ES systems using batteries, which can improve the system performance in terms of power quality, fault ride-through, and energy management, as mentioned in Section II. For such applications, many battery cells are adopted to form battery packs.

Generally, ES devices can be integrated through the dc-coupling technology or at the ac side, as shown in Fig. 14. For the dc-coupling solution, it is typically implemented together with REN systems, e.g., WT systems. For the ac-coupling solution, it is considered a centralized solution, which can be optimally installed at certain places in the power grid. According to He et al. [65], the dc-coupling solution can be more reliable with redundancy, while centralized solutions are favorable in grid applications. Nonetheless, different from the power converters for wind and solar PV systems, the power electronic converters for ES systems are required to operate more frequently in a bidirectional way to charge and discharge the ES devices, e.g., batteries. An EMS or a battery EMS is required to achieve charging/discharging control and monitor the state of charge (SOC) of the battery cells in order to ensure operation safety. With respect to power electronics, the standardized power converters that can be used for ES systems are shown in Fig. 8(a), which are typically for low-power and LV applications, such as line-interactive uninterruptible power supplies (UPSs), as distributed solutions. It should be noted for ES applications that the standardized power converters may pose a large dc-link voltage ripple that is harmful to the batteries. Thus, additional efforts should be devoted to reducing the dc-link voltage ripple through advanced control or topological modifications [5].

In order to handle higher voltages, line-frequency step-up transformers should be adopted to boost the two-level output voltages to tens of kilovolts (i.e., an MV grid). However, this solution will become bulky and less efficient,

especially for higher power applications, requiring multiple parallel systems. As an alternative, bidirectional multilevel power converters, e.g., Fig. 8(b), have been proposed in the literature to handle higher voltages and higher power ratings. For example, the multilevel topologies based on the diode-clamped, flying-capacitor, and cascaded techniques are suitable for such applications. Like the multilevel converters used for wind and solar PV systems, they can provide better power quality with lower THD and lower EMI. Fig. 15 shows an example of battery-ES systems based on an MMC for utility-scale applications, where batteries are connected to individual submodules (SMs), i.e., as multiple dc sources. More can be found in [70], [71], and [72]. Notably, many batteries can be connected in series or parallel to form a common HVdc source, which is then connected to the dc rails of an MMC. Thanks to the fast development of HV SiC devices, it is anticipated that ES systems with multilevel and SiC technologies can directly be connected to MV distribution systems. Significant research efforts have been devoted to multilevel converter technologies, which are able to integrate ES devices both in a centralized and distributed way. Along with the declining ES price, it further enables the large-scale integration of REN resources, as ES devices can provide much flexibility to the system.

E. Power Converters for HVdc Transmission

Cost and energy efficiency are the foremost indicators of REN utilization. In terms of power transmission, compared to HVac transmission technology, HVdc technology has lower transmission losses. Fig. 16 shows the general configuration of an HVdc system, where the terminal Sub-

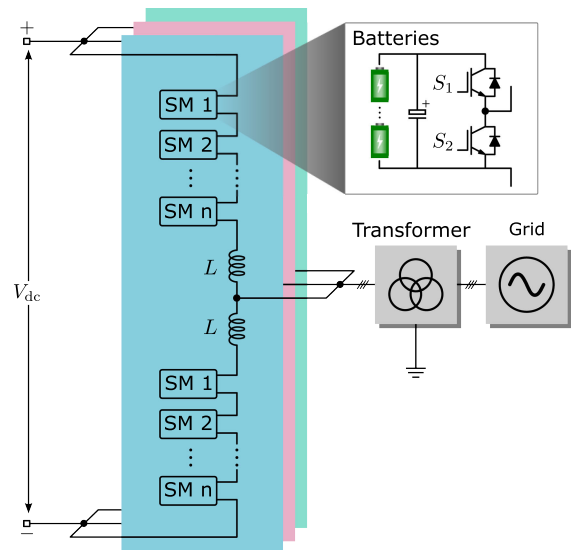

Fig. 15. Example of utility-scale ES systems based on the MMC technology, where the batteries are connected to each individual SM. Here, V_{dc} denotes the voltage at the dc rails, L is the arm inductor, and $S_{1,2}$ represent(s) IGBT modules.

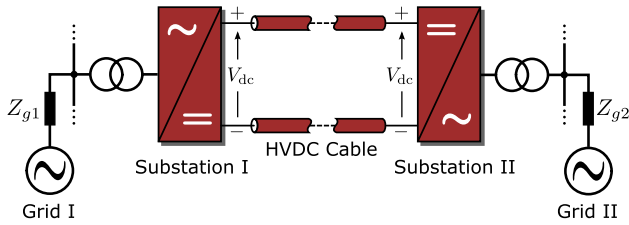

Fig. 16. General configuration of an HVdc system connecting two ac grids (Grid I and Grid II), where V_{dc} is the HVdc voltage, and Z_{g1} and Z_{g2} are the grid impedance for Grid I and Grid II, respectively.

stations (I and II) are power electronic-based, and many power electronics devices are adopted to accommodate the high dc voltage (V_{dc}). In this regard, the HVdc substations are more expensive than the terminals for an HVac system. However, the cables of an HVdc system are cheaper (i.e., fewer conductors are needed) compared to those for an HVac transmission system under the same power level. Furthermore, the HVdc technology outperforms the HVac technology in terms of fast and accurate power flow control, elimination of intermediate substations for reactive power compensation, and a relatively constant voltage in the line. In all, the HVdc technology is economically viable for long-distance power transmission, and thus, it is increasingly employed in large-scale REN power generation systems [58]. At the same time, challenges related to dc circuit breakers and multiterminal dc systems still need to be properly addressed.

In terms of the power electronics converters for the HVdc systems, conventional power substations are based on silicon-controlled rectifiers (thyristors), which are very robust and low-cost. With thyristors, line-commutated converters (LCCs) have been developed and implemented in practical HVdc projects. By its name, the LCC-based HVdc systems are not fully controllable, and their turn-off occurs according to the ac line current. In addition, the power quality is of concern for LCC converters, where reactive power will be consumed, and large filters will be required. To address this, multiphase transformers are adopted, as shown in Fig. 17, while the overall volume is increased significantly. In all, the LCC configuration for HVdc transmission systems has several benefits, such as low costs, high robustness, and simple structures, and multipulse LCC converter bridges enable the reduction of harmonics. However, the controllability is generally low, which drives the development of VSC-based HVdc terminal substations, especially facing the demand for flexible control of large-scale REN generation systems. This is also due to the limited space of offshore platforms.

The basic two- or three-level converters for the VSCs to build an HVdc substation are those shown in Fig. 8. In such applications, the pulsewidth modulation (PWM) strategies are adopted to fully control the power electronics, e.g., IGBTs, where harmonics can be controlled to a

lower level. In practice, to maintain low switching losses, especially for high-power applications, two- or three-level converters should not be switched at a high frequency (usually around 1 kHz or below). As a result, large harmonics will be generated, which will then increase the ac filtering requirements. With these concerns, the MMC systems have been increasingly utilized in practical HVdc projects. Compared to other solutions, the MMC-based HVdc technology has the benefits of low conversion losses, high power quality, and full controllability. This enables the independent control of the active and reactive power through the MMCs [58], [66]. The basic unit of an MMC is the SM, which can be a half- or full-bridge converter, as shown in Fig. 18. Notably, beyond the long-distance power transmission, the HVdc technology can also be used to connect ac systems (with different frequencies), e.g., the interconnection of Japan’s East and West power grids, and other interconnections in Canada and the USA.

To transfer a considerable amount of power, the HVdc systems can be configured in different ways, i.e., a bipolar and monopolar structure [66]. For the bipolar configuration, there is a positive pole and a negative pole, while the monopolar system just has one pole (either a positive or negative pole). Notably, the return current for the monopolar system may become an issue in a long-term operation. Monopolar systems can also occur in faulty bipolar systems (i.e., one pole fails). In both cases, the LCC and VSC units can be employed as the terminal substations; or they can be combined [66]. Power converters can also be connected in parallel or in series in the terminal substations to handle higher power. Finally, it is worth noting that, due to the maturity of MMCs and the advancements in power electronics, multiterminal dc technology is gaining popularity in the integration of large-scale REN generation systems.

IV. CONTROL AND OPERATION OF RENEWABLE ENERGY GENERATION

As discussed previously, power electronics is the key to the capture, processing, and delivery of various REN resources. The performance of an individual large-scale REN power generation is, thus, dependent on the power converter

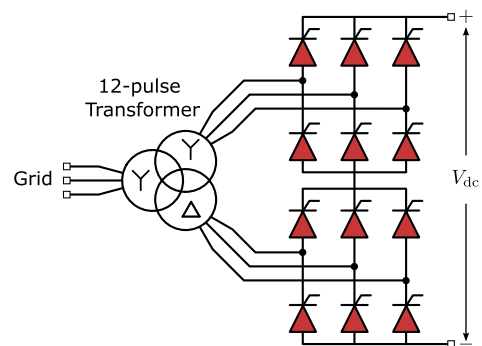

Fig. 17. 12-pulse thyristor-bridges for LCC-based HVdc terminal substations, where V_{dc} is the dc-link voltage.

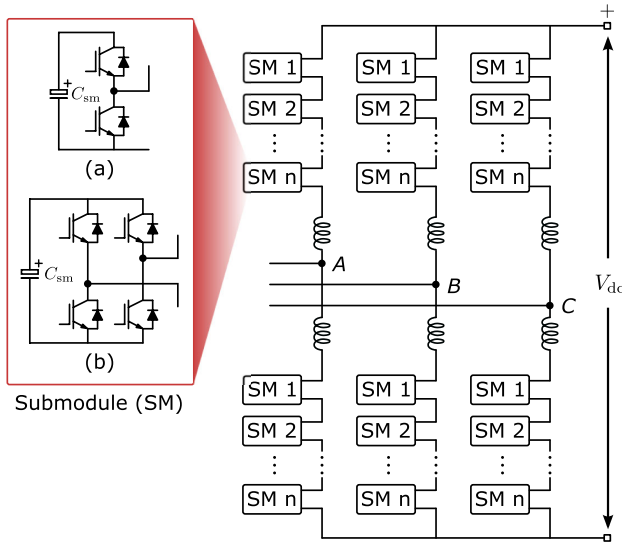

Fig. 18. MMC-based HVdc terminal substations: (a) half-bridge SM and (b) full-bridge SM, where C_{sm} is the SM capacitor and V_{dc} is the dc-link voltage.

hardware design. At the same time, the control applied to power converters for REN generation systems is of significance, as it is the brain of energy utilization, especially for system-level coordinated operation. In this section, the general control and operation of REN power generation systems are presented, including the basic control of individual power converters and cooperative operation of multiple converters in large-scale REN power generation systems.

A. General Control of Individual REN Systems

As the intermediate stage of REN resources and the load or the power grid, power electronics converters should be properly controlled. For one thing, individual power converters are assembled with many switching devices, where the control is used to realize the conversion or conditioning from one type of current to another. In addition, in

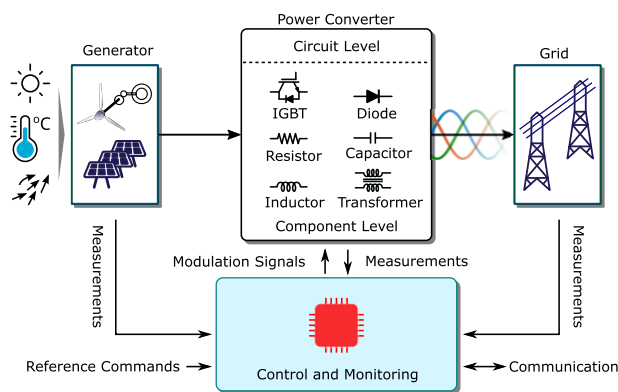

Fig. 19. General control structure of individual renewable power generation systems.

large-scale grid-connected applications of REN generation systems, the control makes the power converters multi-functional, as presented in Section II, and accordingly, various functions can be met, improving the integration performance. Fig. 19 shows the general control architecture of an individual REN power generation system. It is emphasized in Fig. 19 that monitoring the status of the power converter using the measurements is an important aspect of advanced control. As for REN integration, a very common function of such a grid-connected converter is to transfer the energy to the grid based on the corresponding characteristics of the REN resource (the power output is dependent on the ambient conditions, e.g., wind speed and irradiance level; see Fig. 19). This is the optimization of power/energy generation, also known as MPPT. There are many MPPT methods in the literature for both wind and PV applications [67].

Referring to Section III, for WT power systems, MPPT control is achieved by regulating the rotational speed of the generators and the pitch angle. It is usually implemented in the generator-side converter, i.e., the ac/dc converter shown in Fig. 10. As for PV power systems, in the case of single-stage power conversion, MPPT control is implemented in the inverter stage (the only power conversion stage). For double-stage systems, the MPPT control can be implemented at the dc–dc converter stage, while the inversion stage is responsible for other functions. In both cases, the dc voltage of the PV systems can be varied to achieve the MPPT operation (i.e., the MPPT block’s output is a dc voltage reference). In all, the purpose of the MPPT control is to maximize the power/energy extraction from the REN resources according to the operating conditions.

For the inverter control, its purpose is to ensure that the power converter injects high power-quality currents (e.g., low THD). Thus, in many applications, the injected grid currents are controlled. This can be done in various reference frames [24], [43], [44], i.e., the natural abc reference frame, the synchronous rotating (dq) reference frame, and the stationary ($\alpha\beta$) reference frame. Usually, a cascaded dual-loop control scheme is adopted, as demonstrated in Fig. 20, where the control is achieved in either the dq - or $\alpha\beta$ -reference frame, corresponding to Fig. 20(a) and (b), respectively. The outer loop can be a voltage control loop (e.g., the dc-link voltage control gives the d -axis current reference) or a power control loop (e.g., the reactive power control generates the q -axis reference current), and then, the reference currents (i_d^* , i_q^*) are obtained. The inner loop is a current control loop to generate PWM signals. Furthermore, as seen in Fig. 20, the reference frame transformations (T_1 and T_2) are necessary to transform the measured variables (three-phase currents and voltages) to the dq -components. In addition, the injected grid currents must be synchronized with the grid voltage, where phase-locked loops (PLLs) are typically adopted. The phase information tracked by the PLLs is also used for the reference frame transformations. Notably, there are many current controllers, e.g., the PI, proportional–resonant (PR),

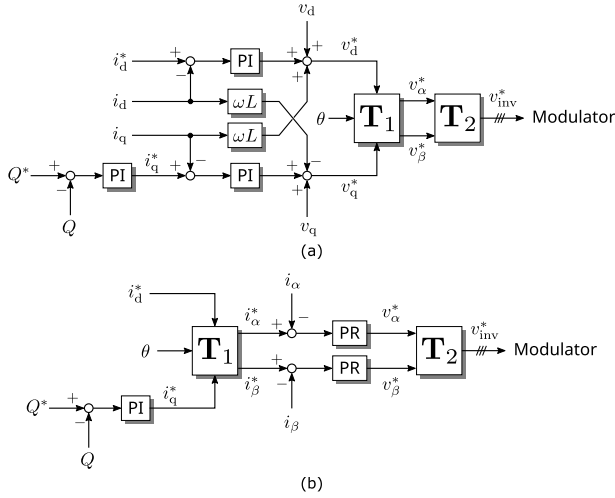

Fig. 20. Typical dual-loop control structure of grid-connected power converters: (a) in the synchronous rotating dq -reference frame and (b) in the stationary $\alpha\beta$ -reference frame, where T_1 and T_2 represent the $dq/\alpha\beta$ and $\alpha\beta/abc$ transformation, respectively. Here, the superscript “*” indicates reference variables, the subscripts “d, q, α , and β ” imply the corresponding component in the dq - and $\alpha\beta$ -reference frames, Q is the reactive power, L is the total filter inductor, ω is the grid frequency, θ is the phase of the grid voltage estimated by a PLL, v_{inv}^* is the modulation signal, and i_d^* can be from a voltage or power control loop.

deadbeat, and repetitive controller, where the PI controllers have been the most widely used ones. It should be noted that nonlinear controllers (e.g., the MPC and the switching sequence control) are gaining interest in the current control of power converters, where the PWM unit may be removed. To meet the current quality requirements (e.g., in the IEEE Std. 1547-2018, the THD of the injected current should be lower than 5%), additional controllers, such as multiresonant controllers, can be adopted to compensate for harmonic distortions.

Beyond the above general control requirements, advanced grid functions should also be performed at the control of the power converters. More specifically, the grid-connected REN generation system should have the following advanced functions [11], [73]: 1) voltage and frequency regulation; 2) robust response to grid disturbances; and 3) ancillary grid support (e.g., black-start and power oscillation damping). An increasing utilization of large-scale REN power generation with power electronics results in even more stringent grid requirements since REN resources are inherently intermittent, as discussed in Sections I and II. For instance, REN generation systems are required to ride-through temporary grid voltage faults and provide dynamic grid support by injecting reactive power. In addition, the grid-connected REN power converters should autonomously respond to frequency disturbances and be able to provide frequency support through active power regulation. More specifically, in the case of an overfrequency incident, the REN generator should reduce its output power to support the frequency; in the case of an underfrequency event, the REN generator should be operating with a power reserve to sufficiently support

(using reserved energy) the grid frequency. Nonetheless, these advanced functions can be achieved by controlling the intermediate stage—the power converters—of REN generation systems.

B. Grid-Forming Control of Large-Scale REN Systems

As aforementioned, advanced grid-functions are required considering the large-scale adoption of power converters, as conventional SGs are being phased out and replaced by “nonrotating” REN generation systems [56]. Seen from the perspective of the physical operating mechanism of power systems, the integration of large-scale REN systems through a massive adoption of power converters makes the grid become inertia-less or low-inertia, challenging its stability and operation [14], [15]. Advanced control functions can be applied to power electronics converters to “harmonize” the operation of slow-response SGs and power converters that have faster dynamics. As discussed previously, the role of power electronic-based REN generation is still mainly to deliver the optimal power to the grid. In this context, conventionally and largely in practical projects, the power converters are controlled as current sources to inject power into the grid and follow the grid “rhythm,” meaning its specific frequency and phase angle. This is called a grid-following operation. As demonstrated previously in Fig. 20, grid-following power converters ensure that the injected currents are synchronized with the utility grid, e.g., through a PLL or a frequency-locked loop (FLL).

In the past, this operation has been sufficient to ensure the stability of a few power converters connected to the strong grid. However, facing the scenario of high-penetration or 100% power electronic-based

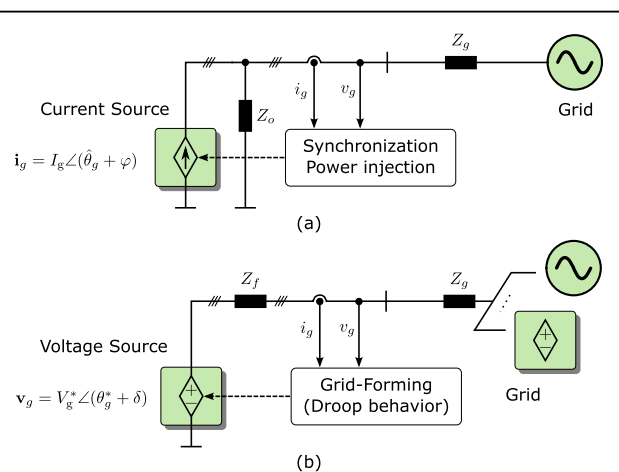

Fig. 21. Equivalent models of grid-connected converters with (a) grid-following control and (b) grid-forming control [74], where i_g , v_g , and Z_g are the grid current, voltage, and impedance, respectively, and i_g and v_g are the reference current and voltage phasors for the grid-following and grid-forming converters, respectively.

REN power generation systems, the grid-following control exposes two significant issues. The first one is that, under large-scale integration of REN systems, it is difficult to implement the grid-following control in many parallel power converters, and sophisticated impedance coupling (between the converters, as well as the converters and the grid impedance) is possibly appearing, which may challenge system instability (leading to resonances and instabilities in the entire system) [74], [75], [76], [77], [78]. The grid may need to be upgraded to increase the stiffness. Then, accommodating large-scale REN systems may require complete grid retrofitting. In other words, it becomes cumbersome and costly to achieve satisfactory performance. In this context, grid-forming technology is emerging and has seen increased development in recent years. The grid-forming operation is becoming more accepted [79] as a promising solution to the integration of large-scale power electronic-based REN systems. Notably, the advanced grid functions should still be implemented. Fig. 21 shows the equivalent operation mechanisms of the grid-following and grid-forming converters. As it is seen in Fig. 21(a), the grid-following control aims to enable the power converters to inject currents by controlling the converters as current sources with impedance in parallel; then, the currents are in phase with the grid voltage (i.e., synchronized). By contrast, the grid-forming scheme aims to operate the power converter as an ideal voltage source with an impedance in series, which can provide a stable and strong voltage at its terminal with a fixed frequency and constant voltage amplitude, as shown in Fig. 21(b). This also enables paralleling of multiple grid-forming inverters. Furthermore, as observed in Fig. 21, compared with the widely used grid-following control, the grid-forming schemes are largely to make the power converters operate like the conventional SGs (to mimic the behavior of SGs) in terms of steady-state and transient performances. However, the fault current capability of a grid-forming inverter is much weaker compared to conventional SGs due to the limited rating of the power converters [15]. At the same time, the fast dynamics of power converters are maintained in grid-forming operation, which may further bring additional benefits to the entire REN generation system.

Up until now, several grid-forming methods have been proposed, including droop control, virtual SG (machine) (VSG), and virtual oscillator control [79], [80], [81], [82]. Fig. 22 briefly compares different control strategies for grid-connected power converters in terms of implementation and operation principles. At present, the grid-forming control is more practically implemented on individual systems, e.g., microgrids. For large-scale REN generation systems, the control of power converters should enable the REN generation units to operate in the islanding mode [79]. Nonetheless, it is increasingly required to achieve a seamless operation mode transition between the grid-connected mode and the islanding mode, as more power converters will be connected to the large-scale REN

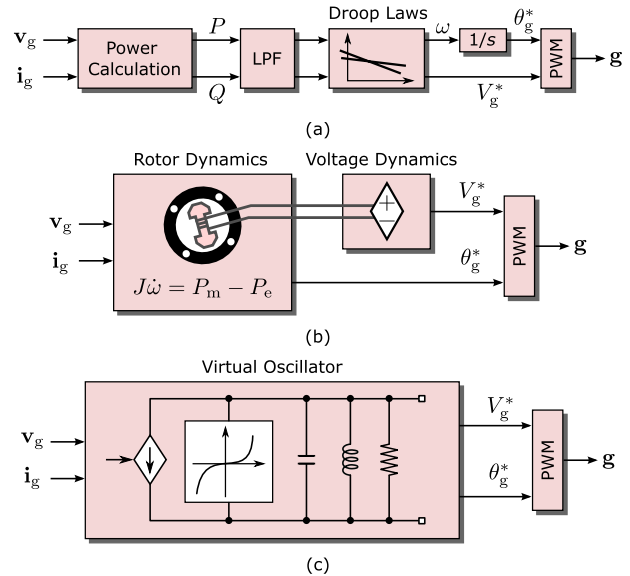

Fig. 22. Grid-forming control strategies for power converters [79], where v_g and i_g are the inverter output voltage and current, correspondingly, g represents the gate signals, $1/s$ is an integrator, V_g^* , θ_g^* is the modulation signal reference voltage and phase, respectively, and ω is the grid frequency: (a) droop control (P and Q are the active and reactive powers), and LPF represents low-pass filters; (b) virtual synchronous generator/machine (J is the moment of inertia, and P_m and P_e are the respective mechanical and electromagnetic powers); and (c) virtual oscillator control.

power generation. In addition, enhancing the emulation of dynamics and fault behaviors of the conventional SGs by grid-forming power converters is also of interest and importance. By doing so, it will be feasible to further develop strategies and advanced control to strengthen grid stability and security. It is also worth mentioning that the ES systems will play an important role in 100% grid-forming converter-based systems.

C. Coordinated Operation of Large-Scale REN Systems

According to the above discussions, the power electronics and the advanced control (e.g., the grid-forming technology) have also been driving the development of more large-scale REN generation systems (in other words, the scalability of power electronic-based REN systems is increasingly important). At the converter level, an individual REN generation system can meet the demands of basic functions, as discussed in Sections II and in the above. Considering the fast integration of ES devices and systems, an energy system consisting of various types of REN resources is approaching. This enables the intelligent operation of multiple units to maximize energy profits and increase energy efficiency. At the system level, various advanced functions and operation modes are becoming feasible. One example is the active power regulation at the system level of a WT power plant. To enhance the grid

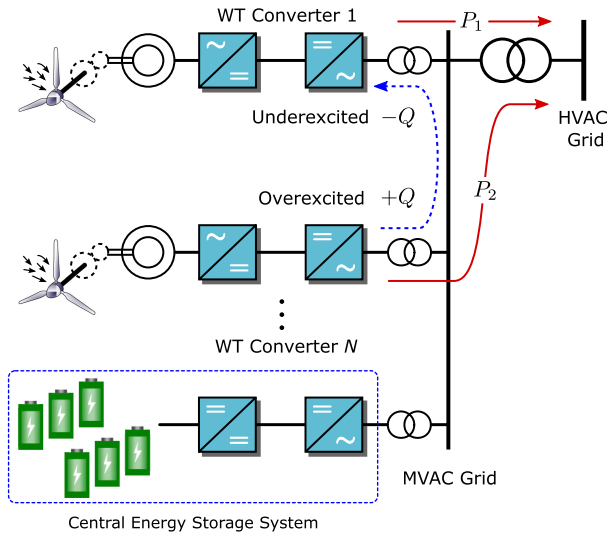

Fig. 23. Reliability improvement of WT power converters through reactive power circulating (coordinated operation) in a wind farm: where Q is circulated reactive power, and P_1 and P_2 are the active powers from the corresponding WT system, respectively. In addition, central ES systems can also be adopted to improve the performance of WT converters and the entire wind farm, as well as to flexibly provide grid support.

robustness and stability, at the system level, the coordinated operation of multiple converters or REN systems provides more flexibility in achieving frequency regulations and voltage control [21]. The overall system stability can be improved as well to some extent, e.g., active damping by certain REN power converters. Even for the grid-forming operation, the control can be achieved at the system level, as presented in [15] and [83].

In addition, the coordinated system-level operation can benefit the converter's performance. By properly managing the power flow among the converters, the overall energy efficiency and system reliability can be enhanced. In particular, the smart charging and discharging of ES devices and systems offer improved flexibility. For example, in [84], the reactive power was circulated in WT power converters, which helped to improve the converter's reliability and thermal performance. The overall system structure is demonstrated in Fig. 23 for a wind farm, which also shows a central ES system connected to the MVac grid. Using ES systems can further improve the performance of WT converters and the entire wind farm, and at the same time, it can provide flexible grid support [85], e.g., doing black start and inertia emulation.

It should be pointed out that, for the coordinated operation and control of large-scale REN systems, a central controller may be necessary to coordinate various REN resources [21], [86], e.g., wind, PV, and ES systems. In this case, a large amount of data may need to be transferred to and processed by a central controller. High-performance data processing chips or controllers are then of interest to achieve optimal online operation of the large-scale REN generation system. For example, as demonstrated in [21],

the central controller collects the status information of the distributed REN systems, and by making an optimal decision, various operation modes are achievable, e.g., the optimal placement of virtual inertia and VSG operation of specific converters. In all, the coordinated operation of large-scale REN systems has huge potential for enhancing system stability and robustness, and it will be needed in the future.

V. CHALLENGES AND FUTURE TRENDS

Although, in this article, many aspects of large-scale REN power generation have been discussed, there are still many possibilities for continuous innovation in various technologies. It is anticipated that a larger range of REN resources will be explored soon, where power electronics is one of the enabling technologies. Along with this foreseen energy transition, concerns such as efficiency, reliability, availability, and cost are common, and further improvements are expected. Seen from the authors' perspective, the following points are of importance for this development and energy transition, which should be tackled properly to achieve grid-friendly integration of various REN resources, in order to reach a 100% power-electronic-based grid.

A. Lower the Cost of Energy

Cost is one of the most important considerations. For REN power generation systems, the cost determines the design and operation of such systems, as discussed in

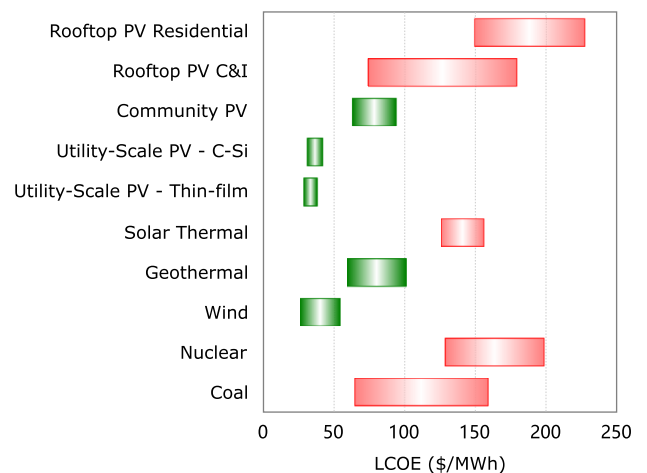

Fig. 24. LCOE comparison of selected REN generation technologies (unsubsidized analysis) [87]. Here, C&I: commercial & industrial and C-Si: crystalline silicon. First, for utility-scale PV power, the low case represents a single-axis tracking system while the high one for a fixed-tilt system. Second, for nuclear, it does not reflect decommissioning costs, ongoing maintenance-related capital costs, or other economic impacts/subsidies. Third, for coal, the high end incorporates 90% carbon capture and storage. It does not include the cost of transportation and storage.

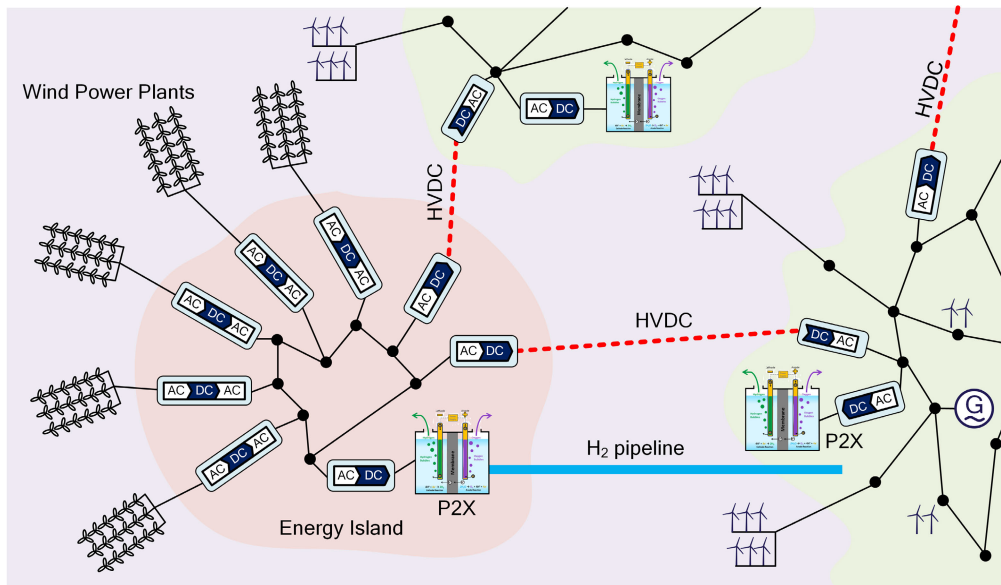

Fig. 25. Energy island with large-scale offshore wind farms, a P2X station on the island, and also power/energy connection to shore, which can be done both electrically and by a gas pipeline (here, HVdc and hydrogen H₂ pipeline). The P2X can also be located on shore. The ac/dc/ac power conversion is shown on the island for the WT connection, but, in practice, it will be in each WT, and here, G represents a synchronous generator.

Sections II and III. A lower cost of energy implies higher competitiveness, which helps to accelerate the pace of phasing out conventional fossil fuels and increase the penetration of REN resources. Many countries or organizations have set goals to continuously lower the cost of energy. To better compare and quantify the costs of various types of REN resources, the levelized cost of energy (LCOE), also referred to as the levelized cost of electricity, has been widely used. At present, the LCOE of REN resources is benchmarked in Fig. 24, which shows that the cost of wind energy and utility-scale PV energy is now comparable to the cost of coal under certain circumstances [87]. Moreover, the cost is predicted to be further lowered [88].

Measures that can be taken to lower the cost of energy include efficiency improvement and reliability enhancement. Both can be achieved through the design and control of the power converters and the overall large-scale REN systems. This further highlights the important role of power electronics in the utilization of large-scale REN power generation. In addition, the advancements in power semiconductor devices in terms of materials (e.g., WBG technologies) and packaging will improve the converter performance to a large extent. When seen from the system perspective, the use of ES devices is also beneficial to the cost of energy reduction through coordinated control, as it has been mentioned in Section IV.

B. Toward Intelligence and Digitalization

The fast development of data science and information technology enables the intelligence and digitization of power electronics conversion systems. The low cost of data

storage has been another driving force, which means that large-scale REN power generation systems must become smarter to meet increasingly stringent demands. As the key component of the physical layers, the power converters will produce a considerable amount of data that should be processed and controlled by the control chips. In this case, the digital control implemented in low-cost control chips is essential and will be increasingly adopted, which should offer fast dynamics and enable operational flexibility for power electronics systems. In this context, the conventional linear control systems may not meet the increasingly complex performance requirements. More advanced nonlinear controllers implemented digitally are expected.

Nevertheless, with intelligent and digital platforms, flexible energy management, smart and advanced control, and so on will be readily implemented and developed. More specifically, for grid-connected large-scale REN power generation systems, multiple functions can be realized to balance production and consumption, e.g., frequency and voltage control. In this regard, the grid-forming technology that can achieve fast and effective voltage/frequency control and realize power dispatch will be further adopted. By then, the coordinated operation of power electronic-based REN generation systems will be even more flexible to maintain the entire system's stability. However, beyond these benefits, smart and digital REN power generations are also susceptible to cybersecurity attackers. That is, the cyber layer has become one of the vulnerable points that can be attacked, possibly resulting in large economical losses. Thus, it is important to develop smart solutions to enhance the security of large-scale

REN power generation systems at both the physical and cyber levels. At the same time, the protection of the entire REN power generation system should be advanced [2].

C. Multienergy Vectors and Integration

This article focuses on WT, solar PV, and battery-ES technologies, but additional REN resources are expected in order to move toward a sustainable and environmental-friendly power generation system. In that case, large-scale REN generation will become multienergy vector-based, e.g., hydropower, heat pumps, electric vehicles (can be considered as mobile storages), and hydrogen pipelines via the power-to-X (P2X) technology, where X can be liquids and gases, e.g., methanol and ammonia, using the electrolysis process. Fig. 25 gives an example of an energy island with the integration of large-scale offshore wind farms, a P2X station, and the interconnection via HVdc technologies and gas pipelines (e.g., a hydrogen H₂ pipeline). When such energy vectors are integrated into the system, the power conversion interfaces are different in rating, configuration, control, and operation, especially with more power electronics converters, as also demonstrated in Fig. 25 (i.e., ac/dc/ac, dc/ac, and ac/dc converters). Therefore, the response of those systems can vary significantly, meaning that the operation and control may be needed at different timescales [21]. If multiple units cannot be harmonized, the system stability and reliability (and, thus, the energy availability) may be challenged. On the other hand, the multienergy vectors offer more controllability to manage the entire power or energy flow, e.g., by performing flexible and smart load control. Although the grid-forming technology can be a promising solution to the integration of multienergy vectors, advanced solutions and tools should be developed to ensure reliability and stability at the system level.

According to the summary in [5] of the research challenges and opportunities for different REN resources until 2025, a general expectation is that, through technological

innovations, REN generation systems will become even more cost-competitive than conventional fossil-fuel power generation systems. The substantial ongoing efforts for integrating much more REN resources into the power grid require an even smarter way to control the entire energy system, not only the electrical system but also the thermal energy, water flow, and others. Doing so requires advanced smart grid functions associated with communications and control, and applying ES in the system.

VI. CONCLUSION

The continuous-increasing demand for environmental-friendly energy generation across the globe has driven the fast development of large-scale REN generation. Among various REN generation technologies, this article has overviewed the technological challenges and developments of wind, PV, and ES systems. Power electronics associated with more advanced control technologies are continually being the key to more inverter-based resources. As such, the energy paradigm and the grid architecture are being transformed digitally, electronically, and intelligently, which further offers opportunities for efficient and flexible energy generation, conversion, transfer, and utilization. At the same time, challenging issues are foreseen. For example, the large-scale REN power generation is inverter-based, which is a type of static generation compared to the generation from conventional rotating SGs. In this case, the integration of large-scale REN makes the utility grid become inertia-less or have reduced inertia. Then, it is less robust to disturbances. Consequently, as presented in this article, solutions such as ES integration and grid-forming control technologies are emerging for large-scale ES generation systems. Also, this can be enhanced by multienergy vector systems through coordinated control. Moreover, the protection of the entire REN system is an emerging issue that still needs to be properly addressed and developed in the future. ■

REFERENCES

- [1] (Apr. 2022). *International Renewable Energy Agency (IRENA)*. Accessed: May 2, 2022. [Online]. Available: <https://www.irena.org/publications/2022/Apr/Renewable-Capacity-Statistics-2022>
- [2] F. Blaabjerg, Y. Yang, D. Yang, and X. Wang, "Distributed power-generation systems and protection," *Proc. IEEE*, vol. 105, no. 7, pp. 1311–1331, Jul. 2017.
- [3] United Nations. *IPCC | Climate Change 2021: The Physical Science Basis*. Accessed: Aug. 10, 2021. [Online]. Available: <https://www.ipcc.ch/report/ar6/wg1/>
- [4] Our World in Data. *Global Direct Primary Energy Consumption*. Accessed: Aug. 2, 2021. [Online]. Available: https://ourworldindata.org/grapher/global-primary-energy?stackMode=relative&time=800.2019&country=~OWID_WRL
- [5] F. Blaabjerg and D. M. Ionel, *Renewable Energy Devices and Systems With Simulations in MATLAB and ANSYS*, 1st ed. Boca Raton, FL, USA: CRC Press, 2018.
- [6] D. Abbott, "Keeping the energy debate clean: How do we supply the world's energy needs?" *Proc. IEEE*, vol. 98, no. 1, pp. 42–66, Jan. 2010.
- [7] B. Kroposki et al., "Achieving a 100% renewable grid: Operating electric power systems with extremely high levels of variable renewable energy," *IEEE Power Energy Mag.*, vol. 15, no. 2, pp. 61–73, Mar./Apr. 2017.
- [8] M. Bragard, N. Soltan, S. Thomas, and R. W. De Doncker, "The balance of renewable sources and user demands in grids: Power electronics for modular battery energy storage systems," *IEEE Trans. Power Electron.*, vol. 25, no. 12, pp. 3049–3056, Dec. 2010.
- [9] Y. Yang, P. Enjeti, F. Blaabjerg, and H. Wang, "Wide-scale adoption of photovoltaic energy: Grid code modifications are explored in the distribution grid," *IEEE Ind. Appl. Mag.*, vol. 21, no. 5, pp. 21–31, Sep./Oct. 2015.
- [10] J. M. Carrasco et al., "Power-electronic systems for the grid integration of renewable energy sources: A survey," *IEEE Trans. Ind. Electron.*, vol. 53, no. 4, pp. 1002–1016, Jun. 2006.
- [11] F. Blaabjerg, Y. Yang, K. Ma, and X. Wang, "Power electronics—The key technology for renewable energy system integration," in *Proc. Int. Conf. Renew. Energy Res. Appl. (ICRERA)*, Nov. 2015, pp. 1618–1626.
- [12] Y. Yang, K. A. Kim, F. Blaabjerg, and A. Sangwongwanich, *Advances in Grid-Connected Photovoltaic Power Conversion Systems*. Duxford, U.K.: Woodhead, 2018.
- [13] M. O'Malley, "Editorial: Towards 100% renewable energy system," *IEEE Trans. Power Syst.*, vol. 37, no. 4, pp. 3187–3189, Jul. 2022.
- [14] *IEEE Standard for Interconnection and Interoperability of Inverter-Based Resources (IBRs) Interconnecting With Associated Transmission Electric Power Systems*, IEEE Standard 2800–2022, pp. 1–180, Apr. 22, 2022.
- [15] (Apr. 2022). *International Renewable Energy Agency (IRENA), Grid Codes for Renewable Powered Systems*. Accessed: May 4, 2022. [Online]. Available: <https://www.irena.org/publications>
- [16] Y. Wang, X. Wang, Z. Chen, and F. Blaabjerg, "Small-signal stability analysis of inverter-fed power systems using component connection method," *IEEE Trans. Smart Grid*, vol. 9, no. 5, pp. 5301–5310, Sep. 2018.
- [17] S. Eftekharijrad, V. Vittal, G. T. Heydt, B. Keel, and J. Loehr, "Small signal stability assessment of power systems with increased penetration of photovoltaic generation: A case study," *IEEE Trans. Sustain. Energy*, vol. 4, no. 4, pp. 960–967, Oct. 2013.

- [18] T. Sadamoto, A. Chakraborty, T. Ishizaki, and J.-I. Imura, "Dynamic modeling, stability, and control of power systems with distributed energy resources: Handling faults using two control methods in tandem," *IEEE Control Syst.*, vol. 39, no. 2, pp. 34–65, Apr. 2019.
- [19] F. Blaabjerg and K. Ma, "Wind energy systems," *Proc. IEEE*, vol. 105, no. 11, pp. 2116–2131, Nov. 2017.
- [20] T. Strasser, "A review of architectures and concepts for intelligence in future electric energy systems," *IEEE Trans. Ind. Electron.*, vol. 62, no. 4, pp. 2424–2438, Apr. 2015.
- [21] Q. Peng, Q. Jiang, Y. Yang, T. Liu, H. Wang, and F. Blaabjerg, "On the stability of power electronics-dominated systems: Challenges and potential solutions," *IEEE Trans. Ind. Appl.*, vol. 55, no. 6, pp. 7657–7670, Nov. 2019.
- [22] H. Alatrash, A. Mensah, E. Mark, G. Haddad, and J. Enslin, "Generator emulation controls for photovoltaic inverters," *IEEE Trans. Smart Grid*, vol. 3, no. 2, pp. 996–1011, Jun. 2012.
- [23] S. Debnath, J. Qin, B. Bahrani, M. Saeedifard, and P. Barbosa, "Operation, control, and applications of the modular multilevel converter: A review," *IEEE Trans. Power Electron.*, vol. 30, no. 1, pp. 37–53, Jan. 2015.
- [24] F. Blaabjerg, R. Teodorescu, M. Liserre, and A. V. Timbus, "Overview of control and grid synchronization for distributed power generation systems," *IEEE Trans. Ind. Electron.*, vol. 53, no. 5, pp. 1398–1409, Oct. 2006.
- [25] H. S.-H. Chung, H. Wang, F. Blaabjerg, and M. Pecht, *Reliability of Power Electronics Converter Systems*. London, U.K.: IET, 2015.
- [26] Y. Xu and C. Singh, "Power system reliability impact of energy storage integration with intelligent operation strategy," *IEEE Trans. Smart Grid*, vol. 5, no. 2, pp. 1129–1137, Mar. 2014.
- [27] B. Chen, J. Wang, X. Lu, C. Chen, and S. Zhao, "Networked microgrids for grid resilience, robustness, and efficiency: A review," *IEEE Trans. Smart Grid*, vol. 12, no. 1, pp. 18–32, Aug. 2021.
- [28] X. Wang, Z. Li, M. Shahidehpour, and C. Jiang, "Robust line hardening strategies for improving the resilience of distribution systems with variable renewable resources," *IEEE Trans. Sustain. Energy*, vol. 10, no. 1, pp. 386–395, Jan. 2019.
- [29] *IEEE Standard for Interconnection and Interoperability of Distributed Energy Resources With Associated Electric Power Systems Interfaces—Amendment 1: To Provide More Flexibility for Adoption of Abnormal Operating Performance Category III*, IEEE Standard 1547–2020 (Amendment to IEEE Standard 1547–2018), pp. 1–16, Apr. 15, 2020.
- [30] S. Eftekharijrad, G. T. Heydt, and V. Vittal, "Optimal generation dispatch with high penetration of photovoltaic generation," *IEEE Trans. Sustain. Energy*, vol. 6, no. 3, pp. 1013–1020, Jul. 2015.
- [31] G. Carpinelli, G. Celli, S. Mocci, F. Mottola, F. Pilo, and D. Proto, "Optimal integration of distributed energy storage devices in smart grids," *IEEE Trans. Smart Grid*, vol. 4, no. 2, pp. 985–995, Jun. 2013.
- [32] S. K. Chaudhary, R. Teodorescu, J. R. Svensson, L. H. Kocewiak, P. Johnson, and B. Berggren, "Black start service from offshore wind power plant using IBESS," in *Proc. IEEE Madrid PowerTech*, Jun. 2021, pp. 1–6.
- [33] P. Zou, Q. Chen, Q. Xia, G. He, and C. Kang, "Evaluating the contribution of energy storages to support large-scale renewable generation in joint energy and ancillary service markets," *IEEE Trans. Sustain. Energy*, vol. 7, no. 2, pp. 808–818, Apr. 2016.
- [34] J. Chang, Y. Du, E. Lim, H. Wen, X. Li, and J. Lin, "Coordinated frequency regulation using solar forecasting based virtual inertia control for islanded microgrids," *IEEE Trans. Sustain. Energy*, vol. 12, no. 4, pp. 2393–2403, Oct. 2021.
- [35] M. R. Sandgani and S. Sirouspour, "Coordinated optimal dispatch of energy storage in a network of grid-connected microgrids," *IEEE Trans. Sustain. Energy*, vol. 8, no. 3, pp. 1166–1176, Jul. 2017.
- [36] S. Zhao, F. Blaabjerg, and H. Wang, "An overview of artificial intelligence applications for power electronics," *IEEE Trans. Power Electron.*, vol. 36, no. 4, pp. 4633–4658, Apr. 2021.
- [37] J. S. Thongam and M. Ouhrouche, "MPPT control methods in wind energy conversion systems," in *Fundamental and Advanced Topics in Wind Power*, R. Cariveau, Ed. InTech, 2011. [Online]. Available: <https://www.intechopen.com/books/205>
- [38] P. Huynh, S. Tungare, and A. Banerjee, "Maximum power point tracking for wind turbine using integrated generator-rectifier systems," *IEEE Trans. Power Electron.*, vol. 36, no. 1, pp. 504–512, Jan. 2021.
- [39] Y. Zhao, R. Ball, J. Mosesian, J. F. D. Palma, and B. Lehman, "Graph-based semi-supervised learning for fault detection and classification in solar photovoltaic arrays," *IEEE Trans. Power Electron.*, vol. 30, no. 5, pp. 2848–2858, May 2015.
- [40] A. Kushwaha, M. Gopal, and B. Singh, "Q-learning based maximum power extraction for wind energy conversion system with variable wind speed," *IEEE Trans. Energy Convers.*, vol. 35, no. 3, pp. 1160–1170, Sep. 2020.
- [41] Sumitomo Electric Industries. (2019). *Sumitomo Electric Develops AI-Based Failure Detection System for Maximizing Output of Photovoltaic Power Plants*. Accessed: May 2, 2022. [Online]. Available: https://sumitomoelectric.com/sites/default/files/2020-12/download_documents/20190118Sumitomo%20Electric%20Develops%20AI-based%20Failure%20Detection%20System%20for%20Maximizing%20Output%20of%20Photovoltaic%20Power%20Plants%20_1.pdf
- [42] J. Millan, P. Godignon, X. Perpina, A. Perez-Tomas, and J. Rebollo, "A survey of wide bandgap power semiconductor devices," *IEEE Trans. Power Electron.*, vol. 29, no. 5, pp. 2155–2163, May 2014.
- [43] S. Kouro, J. I. Leon, D. Vinnikov, and L. G. Franquelo, "Grid-connected photovoltaic systems: An overview of recent research and emerging PV converter technology," *IEEE Ind. Electron. Mag.*, vol. 9, no. 1, pp. 47–61, Mar. 2015.
- [44] D. Xu, F. Blaabjerg, W. Chen, and N. Zhu, *Advanced Control of Doubly Fed Induction Generator for Wind Power Systems*. Hoboken, NJ, USA: Wiley, 2018.
- [45] S. Kouro, P. Cortes, R. Vargas, U. Ammann, and J. Rodriguez, "Model predictive control—A simple and powerful method to control power converters," *IEEE Trans. Ind. Electron.*, vol. 56, no. 6, pp. 1826–1838, Jun. 2009.
- [46] Q. Xu, T. Dragicevic, L. Xie, and F. Blaabjerg, "Artificial intelligence-based control design for reliable virtual synchronous generators," *IEEE Trans. Power Electron.*, vol. 36, no. 8, pp. 9453–9464, Aug. 2021.
- [47] X. She, A. Q. Huang, and R. Burgos, "Review of solid-state transformer technologies and their application in power distribution systems," *IEEE J. Emerg. Sel. Topics Power Electron.*, vol. 1, no. 3, pp. 186–198, Sep. 2013.
- [48] L. F. Costa, G. D. Carne, G. Buticchi, and M. Liserre, "The smart transformer: A solid-state transformer tailored to provide ancillary services to the distribution grid," *IEEE Power Electron. Mag.*, vol. 4, no. 2, pp. 56–67, Jun. 2017.
- [49] S. Vazquez, S. M. Lukic, E. Galvan, L. G. Franquelo, and J. M. Carrasco, "Energy storage systems for transport and grid applications," *IEEE Trans. Ind. Electron.*, vol. 57, no. 12, pp. 3881–3895, Dec. 2010.
- [50] Wikipedia. *Grid Energy Storage*. Accessed: Sep. 11, 2021. [Online]. Available: https://en.wikipedia.org/wiki/Grid_energy_storage#Energy_storage_for_grid_applications
- [51] J. P. Barton and D. G. Infield, "Energy storage and its use with intermittent renewable energy," *IEEE Trans. Energy Convers.*, vol. 19, no. 2, pp. 441–448, Jun. 2004.
- [52] C. K. Das, O. Bass, G. Kothapalli, T. S. Mahmoud, and D. Habibi, "Overview of energy storage systems in distribution networks: Placement, sizing, operation, and power quality," *Renew. Sustain. Energy Rev.*, vol. 91, pp. 1205–1230, Aug. 2018.
- [53] F. Nadeem, S. S. Hussain, P. K. Tiwari, A. K. Goswami, and T. S. Ustun, "Comparative review of energy storage systems, their roles, and impacts on future power systems," *IEEE Access*, vol. 7, pp. 4555–4585, 2018.
- [54] K. Mongird, V. Viswanathan, J. Alam, C. Vartanian, and V. Sprenkle, "2020 grid energy storage technology cost and performance assessment," Pacific Northwest Nat. Lab. (PNNL), Richland, WA, USA, Tech. Rep. DOE/PA-0204, Dec. 2020. Accessed: Jun. 25, 2023. [Online]. Available: <https://www.pnnl.gov/sites/default/files/media/file/Final%20-%20ESGC%20Cost%20Performance%20Report%202012-11-2020.pdf>
- [55] G. F. Farivar et al., "Grid-connected energy storage systems: State-of-the-art and emerging technologies," *Proc. IEEE*, early access, Jun. 28, 2022, doi: 10.1109/JPROC.2022.3183289.
- [56] M. Chen et al., "Power converter technologies for DER," presented at the IEEE Int. Roadmap Power Electron. Distrib. Energy Resour. (ITRD), IEEE Annu. Energy Convers. Congr. Expo. (ECCE), Oct. 2021.
- [57] H. Wang and F. Blaabjerg, "Power electronics reliability: State of the art and outlook," *IEEE J. Emerg. Sel. Topics Power Electron.*, vol. 9, no. 6, pp. 6476–6493, Dec. 2021.
- [58] K. Schonleber, A. Oudalov, A. Krontriss, and P. Lundberg, "Opportunities for embedded high-voltage direct current: Evaluating the benefits for the legacy AC grid," *IEEE Power Energy Mag.*, vol. 18, no. 5, pp. 58–63, Sep. 2020.
- [59] T. Ericson, "Power electronic building blocks—A systematic approach to power electronics," in *Proc. Power Eng. Soc. Summer Meeting*, 2000, pp. 1216–1218.
- [60] *Siemens Gamesa, Product Brochures*. Accessed: Aug. 28, 2021. [Online]. Available: <https://www.siemensgamesa.com/-/media/siemensgamesa/downloads/en/products-and-services/offshore/brochures/siemens-gamesa-offshore-wind-turbine-brochure-sg-14-222-dd.pdf>
- [61] *Vestas, Product Brochure*. Accessed: Sep. 10, 2021. [Online]. Available: <https://noezbra.ipacperms.dk/Vestas/Communication/Productbrochure/OffshoreProductBrochure/v236-150-mw-brochure/?page=1>
- [62] V. Yaramasu, B. Wu, P. C. Sen, S. Kouro, and M. Narimani, "High-power wind energy conversion systems: State-of-the-art and emerging technologies," *Proc. IEEE*, vol. 103, no. 5, pp. 740–788, May 2015.
- [63] *Trina Solar, Product Brochures*. Accessed: Aug. 28, 2021. [Online]. Available: <https://static.trinasolar.com/sites/default/files/BrochureVerte670W-EN.pdf>
- [64] Z. Corba, B. Popadic, V. Katic, B. Dumnic, and D. Milicevic, "Future of high power PV plants—1500 V inverters," in *Proc. Int. Symp. Power Electron. (Ee)*, Oct. 2017, pp. 1–5.
- [65] J. He, Y. Yang, and D. Vinnikov, "Energy storage for 1500 V photovoltaic systems: A comparative reliability analysis of DC- and AC coupling," *Energies*, vol. 13, no. 13, pp. 1–16, 2020.
- [66] K. O. Papailiou, *Springer Handbook of Power Systems*. Berlin, Germany: Springer, 2021.
- [67] J. P. Ram, N. Rajasekar, and M. Miyatake, "Design and overview of maximum power point tracking techniques in wind and solar photovoltaic systems: A review," *Renew. Sustain. Energy Rev.*, vol. 73, pp. 1138–1159, Jun. 2017.
- [68] F. M. Alhuwaisheh, A. K. Allehyani, S. A. S. Al-Obaidi, and P. N. Enjeti, "A medium-voltage DC-collection grid for large-scale PV power plants with interleaved modular multilevel converter," *IEEE J. Emerg. Sel. Topics Power Electron.*, vol. 8, no. 4, pp. 3434–3443, Dec. 2020.
- [69] P. Lechner et al., "Extreme testing of PID resistive C-Si PV modules with 1500 V system voltage," in *Proc. PVSEC*, 2021, pp. 792–795.
- [70] Y. Xu, Z. Zhang, G. Wang, and Z. Xu, "Modular multilevel converter with embedded energy storage for bidirectional fault isolation," *IEEE Trans. Power Del.*, vol. 37, no. 1, pp. 105–115, Feb. 2022.
- [71] S. Wang, A. M. Massoud, and B. W. Williams, "A T-type modular multilevel converter," *IEEE J.*

- Emerg. Sel. Top. Power Electron.*, vol. 9, no. 1, pp. 843–857, Feb. 2021.
- [72] T. Soong and P. W. Lehn, "Assessment of fault tolerance in modular multilevel converters with integrated energy storage," *IEEE Trans. Power Electron.*, vol. 31, no. 6, pp. 4085–4095, Jun. 2016.
- [73] Z. Tang, Y. Yang, and F. Blaabjerg, "Power electronics—The enabling technology for renewable energy integration," *CSEE J. Power Energy Syst.*, vol. 8, no. 1, pp. 39–52, Jan. 2022.
- [74] J. Rocabert, A. Luna, F. Blaabjerg, and P. Rodríguez, "Control of power converters in AC microgrids," *IEEE Trans. Power Electron.*, vol. 27, no. 11, pp. 4734–4749, Dec. 2012.
- [75] M. Lu, Y. Yang, B. Johnson, and F. Blaabjerg, "An interaction-admittance model for multi-inverter grid-connected systems," *IEEE Trans. Power Electron.*, vol. 34, no. 8, pp. 7542–7557, Aug. 2019.
- [76] C. Wan, M. Huang, C. K. Tse, and X. Ruan, "Effects of interaction of power converters coupled via power grid: A design-oriented study," *IEEE Trans. Power Electron.*, vol. 30, no. 7, pp. 3589–3600, Jul. 2015.
- [77] Y. Zhang and Y. W. Li, "Detailed analysis of DC-link virtual impedance-based suppression method for harmonics interaction in high-power PWM current-source motor drives," *IEEE Trans. Power Electron.*, vol. 30, no. 9, pp. 4646–4658, Sep. 2015.
- [78] N. Cifuentes, M. Sun, R. Gupta, and B. C. Pal, "Black-box impedance-based stability assessment of dynamic interactions between converters and grid," *IEEE Trans. Power Syst.*, vol. 37, no. 4, pp. 2976–2987, Jul. 2022.
- [79] Y. Lin et al., "Technical roadmap guides research direction for grid-forming inverters," Nat. Renew. Energy Lab. (NREL), Golden, CO, USA, Tech. Rep. NREL/TP-5D00-73476, Nov. 2020, Accessed: Aug. 28, 2021. [Online]. Available: <https://www.nrel.gov/docs/fy21osti/73476.pdf>
- [80] J. Driesen and K. Visscher, "Virtual synchronous generators," in *Proc. IEEE PES Gen. Meeting-Converters. Del. Electr. Energy*, Jul. 2008, pp. 1–3.
- [81] H.-P. Beck and R. Hesse, "Virtual synchronous machine," in *Proc. 9th Int. Conf. Electr. Power Quality Utilisation*, Oct. 2007, pp. 1–6.
- [82] J. Fang, H. Li, Y. Tang, and F. Blaabjerg, "On the inertia of future more-electronics power systems," *IEEE J. Emerg. Sel. Topics Power Electron.*, vol. 7, no. 4, pp. 2130–2146, Dec. 2019.
- [83] A. Tarraso, N. B. Lai, C. Verdugo, J. I. Candela, and P. Rodríguez, "Design of controller for virtual synchronous power plant," *IEEE Trans. Ind. Appl.*, vol. 57, no. 4, pp. 4033–4041, Jul. 2021.
- [84] K. Ma, M. Liserre, and F. Blaabjerg, "Reactive power influence on the thermal cycling of multi-MW wind power inverter," *IEEE Trans. Ind. Appl.*, vol. 49, no. 2, pp. 922–930, Mar./Apr. 2013.
- [85] J. Rocabert, R. Capó-Misut, R. S. Muñoz-Aguilar, J. I. Candela, and P. Rodríguez, "Control of energy storage system integrating electrochemical batteries and supercapacitors for grid-connected applications," *IEEE Trans. Ind. Appl.*, vol. 55, no. 2, pp. 1853–1862, Mar./Apr. 2019.
- [86] B.-I. Craciun, T. Kerekes, D. Sera, and R. Teodorescu, "Frequency support functions in large PV power plants with active power reserves," *IEEE J. Emerg. Sel. Topics Power Electron.*, vol. 2, no. 4, pp. 849–858, Dec. 2014.
- [87] Lazard. *Lazard's Levelized Cost of Energy Analysis—Version 14.0*. Accessed: Aug. 26, 2021. [Online]. Available: <https://www.lazard.com/media/451419/lazards-levelized-cost-of-energy-version-140.pdf>
- [88] Fraunhofer ISE. *Levelized Cost of Electricity: Renewables Clearly Superior to Conventional Power Plants Due to Rising CO₂ Prices*. Accessed: Dec. 1, 2022. [Online]. Available: <https://www.ise.fraunhofer.de/en/press-media/press-releases/2021/levelized-cost-of-electricity-renewables-clearly-superior-to-conventional-power-plants-due-to-rising-co2-prices.html>

ABOUT THE AUTHORS

Frede Blaabjerg (Fellow, IEEE) received the Ph.D. degree in electrical engineering from Aalborg University, Aalborg, Denmark, in 1995.

He was with ABB-Scandia, Randers, Denmark, from 1987 to 1988. He became an Assistant Professor in 1992, an Associate Professor in 1996, and a Full Professor of power electronics and drives in 1998 at AAU Energy, Aalborg University. In 2017, he became a Villum Investigator. He received the honoris causa at the Politehnica University of Timisoara (UPT), Timisoara, Romania, in 2017, and the Tallinn University of Technology (TTU), Tallinn, Estonia, in 2018. He has published more than 600 journal articles in the fields of power electronics and its applications. He is a coauthor of eight monographs and an editor of 14 books on power electronics and its applications. His current research interests include power electronics and its applications, such as in wind turbines, photovoltaic (PV) systems, reliability, Power-2-X, power quality, and adjustable speed drives.

Dr. Blaabjerg received 38 IEEE Prize Paper Awards, the IEEE PELS Distinguished Service Award in 2009, the EPE-PEMC Council Award in 2010, the IEEE William E. Newell Power Electronics Award in 2014, the Villum Kann Rasmussen Research Award in 2014, the Global Energy Prize in 2019, and the 2020 IEEE Edison Medal. He was nominated in 2014–2021 by Thomson Reuters to be among the Most 250 Cited Researchers in Engineering in the World. He was the Editor-in-Chief of the IEEE TRANSACTIONS ON POWER ELECTRONICS from 2006 to 2012. He has been a Distinguished Lecturer of the IEEE Power Electronics Society from 2005 to 2007 and the IEEE Industry Applications Society from 2010 to 2011 and 2017 to 2018. From 2019 to 2020, he has served as the President of the IEEE Power Electronics Society. He has been the Vice-President of the Danish Academy of Technical Sciences.



Yongheng Yang (Senior Member, IEEE) received the B.Eng. degree in electrical engineering and automation from Northwestern Polytechnical University, Xi'an, China, in 2009, and the Ph.D. degree in energy technology from Aalborg University, Aalborg, Denmark, in 2014.

He pursued postgraduate studies at Southeast University, Nanjing, China, from 2009 to 2011, and was a Visiting Scholar with Texas A&M University, College Station, TX, USA, from March to May 2013. From 2014 to 2020, he was associated with the Department of Energy Technology, Aalborg University, where he achieved the rank of tenured Associate Professor in 2018. In January 2021, he joined Zhejiang University, Hangzhou, China, as a ZJU100 Professor. He became a Zhejiang Kungpeng Investigator in 2023. His research focuses on grid integration of photovoltaic systems and control of power converters, specifically grid-forming control technologies.

Dr. Yang is also a Council Member of the China Power Supply Society. He received the 2018 IET Renewable Power Generation Premium Award and was recognized as an Outstanding Reviewer for the IEEE TRANSACTIONS ON POWER ELECTRONICS in 2018. He was a recipient of the 2021 Richard M. Bass Outstanding Young Power Electronics Engineer Award from the IEEE Power Electronics Society (PELS) and the 2022 IEEJ Isao Takahashi Power Electronics Award. In addition, he received two IEEE Best Paper Awards. He was included on the list of Highly Cited Chinese Researchers by Elsevier in 2022. He has served as the Chair of the IEEE Denmark Section from 2019 to 2020. He is an Associate Editor for several IEEE Transactions. He is also the Vice-Chair of the IEEE PELS Technical Committee on Sustainable Energy Systems.



Katherine A. Kim (Senior Member, IEEE) received the B.S. degree in electrical and computer engineering from the Franklin W. Olin College of Engineering, Needham, MA, USA, in 2007, and the M.S. and Ph.D. degrees in electrical and computer engineering from the University of Illinois at Urbana-Champaign, Champaign, IL, USA, in 2011 and 2014, respectively.



From 2014 to 2018, she was an Assistant Professor of electrical and computer engineering with the Ulsan National Institute of Science and Technology (UNIST), Ulsan, South Korea. Since 2019, she has been an Associate Professor of electrical engineering with National Taiwan University, Taipei, Taiwan. Her research focuses on power electronics and control for solar photovoltaic applications.

Dr. Kim received the Award for Achievements in Power Electronics Education from the IEEE Power Electronics Society (PELS) in 2022, the Richard M. Bass Outstanding Young Power Electronics Engineer Award from PELS in 2019, and the recognition as an Innovator Under 35 for the Asia Pacific Region by the MIT Technology Review in 2020. For IEEE PELS, she has served as the Student Membership Chair from 2013 to 2014, a Member at Large from 2016 to 2018, and the Women in Engineering Chair from 2018 to 2020, and will be serving as the PELS Constitution and Bylaws Chair for the term 2021–2024. Since 2017, she has been serving as an Associate Editor for the IEEE TRANSACTIONS ON POWER ELECTRONICS.

Jose Rodriguez (Life Fellow, IEEE) received the Engineer degree in electrical engineering from the Universidad Técnica Federico Santa María, Valparaíso, Chile, in 1977, and the Dr.Ing. degree in electrical engineering from the University of Erlangen, Erlangen, Germany, in 1985.



He has been with the Department of Electronics Engineering, Universidad Técnica Federico Santa María, since 1977, where he was a Full Professor and the President. From 2015 to 2019, he was the President of the Universidad Andrés Bello, Santiago, Chile. Since 2022, he has been the President of the Universidad San Sebastian, Santiago. He has coauthored two books, several book chapters, and more than 700 journal articles and conference papers. His main research interests include multilevel inverters, new converter topologies, control of power converters, and adjustable-speed drives.

Dr. Rodriguez is a member of the Chilean Academy of Engineering. He received a number of best paper awards from the IEEE journals. In 2014, he received the National Award of Applied Sciences and Technology from the Government of Chile. In 2015, he received the Eugene Mittelmann Award from the IEEE Industrial Electronics Society. From 2014 to 2022, he was included in the list of Highly Cited Researchers published by Web of Science.