

Design and Experimental Investigation of Decode-and-Forward and Amplify-and-Forward Relaying FSO-CDMA

Jianhua Ji , Jiahe Zhang, Ke Wang, Ming Xu , and Yufeng Song

Abstract—The scheme of combining relay and optical code division multiple access (OCDMA) is one of the effective methods to improve the reliability and security of free space optical (FSO) communication system. We experimentally investigate a 10 Gb/s decode-and-forward (DF) relaying FSO-CDMA system and a relaying amplify-and-forward (AF) FSO-CDMA system, respectively. Bit error rates (BERs) of DF and AF relaying FSO-CDMA are measured and compared under different turbulence conditions. The experimental results show that the BER of DF relaying FSO-CDMA is one to two orders of magnitude lower than that of AF relaying FSO-CDMA when the receiving power is -5.6 dBm. However, the performance gap is decreasing with the increase of receiving power, especially when there is an interfering user. At the receiving power -2.8 dBm, two-user AF and DF relaying FSO-CDMA systems have almost the same BER. Under both weak and moderate turbulence conditions, at the receiving power -2.8 dBm, the measured BER of the eavesdropper exceeds 0.1, which is larger than the BER threshold of soft-decision forward error correction code. Hence, physical layer security of FSO relaying system can be achieved by optical coding.

Index Terms—Free space optical communication, optical code division multiple access, amplify-and-forward relaying, decode-and-forward relaying.

I. INTRODUCTION

FREE space optical (FSO) communication has been used for satellite-to-ground communication system and terrestrial wireless optical access network [1]. However, atmospheric turbulence and attenuation can degrade the reliability. Some mitigation techniques can be used to improve the reliability, including channel coding [2], diversity [3], and relay communication [4], [5], [6], [7], [8]. Relay assisted communication can be divided into decode-and-forward (DF) and amplify-and-forward (AF)

modes. Both AF and DF multi-hop systems were analytically tested on a 5 km link, and the results show that the power margin was improved by 12.2 and 18.5 dB, respectively. All-optical relaying system based on erbium-doped fiber amplifiers (EDFAs) were analyzed [9], and accurate noise model for all-optical relaying system was established. In [10], a 10 Gb/s triple-hop AF relaying FSO system was investigated. The authors demonstrated a 10 Gb/s all-optical FSO relaying system with two links and an all-optical switch [11], and the results show that bit error rate (BER) can be improved by using a dual-hop link. In [12], both parallel and serial relaying modes are studied. The outage probability of a multi-hop relaying FSO system was examined [13], and the results show that the performance of the DF system is slightly better than that of the AF system. Performances of relaying FSO system using channel state information and fixed-gain relay were studied theoretically [14].

On the other hand, FSO links may suffer from eavesdropping risks due to beam spreading and atmospheric scattering [15], [16]. Eavesdroppers (Eve) can effectively detect signals in the divergent region of the beam. In practice, Eve can place the eavesdropping receiver in the laser beam area behind the legitimate user's receiver. For FSO communication system with longer transmission links, the chance of successful eavesdropping will be greater. An effective solution is to use physical layer security mechanisms. Among them, optical code division multiple access (OCDMA) can not only realize multi-user transmission, but also enhance optical layer security [17], [18]. The authors theoretically studied the relay-assisted underwater wireless OCDMA [19], and the numerical results show that the performance can be improved by using relays. The wiretap channel model of EDFA-based relaying FSO-CDMA was proposed, and performance of physical layer security was analyzed theoretically [20]. In previous work [21], we demonstrated a single-user 10 Gb/s EDFA-based all-optical relaying FSO-CDMA wiretap channel. Experimental results show that reliability of the legitimate user is enhanced significantly.

Although there have been few numerical studies on the performances of DF and AF relaying FSO-OCDMA system, experimental investigation and comparison of DF and AF relaying FSO-CDMA systems have not been reported. In this paper, we build and investigate two-user 10 Gb/s DF relaying FSO-CDMA system and two-user 10 Gb/s AF relaying FSO-CDMA system respectively. BERs are measured and compared for the first time,

Manuscript received 10 June 2022; revised 29 August 2022; accepted 10 September 2022. Date of publication 14 September 2022; date of current version 22 September 2022. This work was supported in part by the National Natural Science Foundation of China under Grant 61671306 and in part by the Fundamental Research Project of Shenzhen under Grants JCYJ20200109105216803 and JCYJ20190808143611709. (Corresponding author: Jianhua Ji.)

Jianhua Ji is with the College of Electronics and Information Engineering, Shenzhen University, Shenzhen 518060, China, and also with the Peng Cheng Laboratory, Shenzhen 518060, China (e-mail: jjh@szu.edu.cn).

Jiahe Zhang, Ke Wang, Ming Xu, and Yufeng Song are with the College of Electronics and Information Engineering, Shenzhen University, Shenzhen 518060, China (e-mail: 2070436012@email.szu.edu.cn; wong@szu.edu.cn; xum@szu.edu.cn; yfsong@szu.edu.cn).

Digital Object Identifier 10.1109/JPHOT.2022.3206434

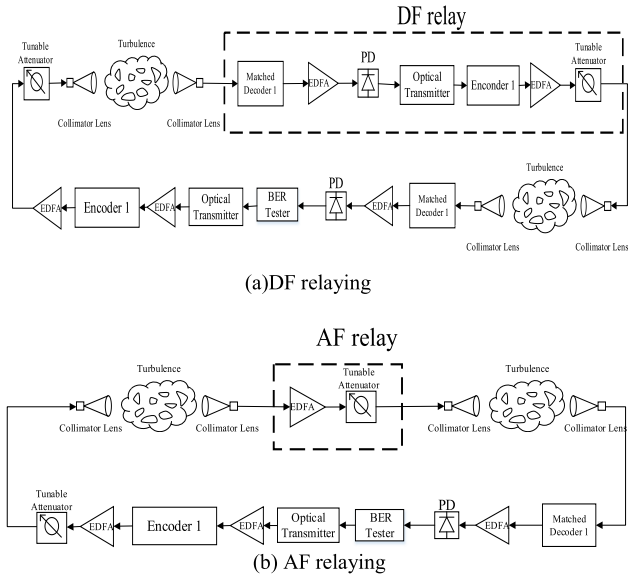

Fig. 1. 10 Gb/s single-user DF relaying FSO-CDMA and AF relaying FSO-CDMA experimental systems.

and physical layer security in two-user AF relaying FSO-CDMA is also investigated. In the performance evaluation of the considered system, this paper focuses on the effects of atmospheric turbulence and attenuation, and the pointing errors are assumed to be negligible.

The remainder of this paper is organized as follows. In Section II, the single-user experimental system of relaying FSO-CDMA will be built. In Section III, two-user experimental system of relaying FSO-CDMA will be investigated. Physical layer security will be discussed in Section IV. Conclusion of this paper will be given in Section V.

II. SINGLE-USER EXPERIMENTAL SYSTEM

Fig. 1(a) shows the single-user 10 Gb/s DF relaying FSO-CDMA experimental system. Firstly, the SeBERT-10G generates random data, which is on-off-keying (OOK) modulated by the optical transmitter SPTX-15PS. The pulse width is 15 ps, and transmitting power is -5 dBm. After an EDFA, the optical signal is encoded by a two-dimensional optical encoder, which is composed of WSS CR50 9×1 ADD/DROP and optical delay lines. The prime-hopping code is $\{(13,53), (52,54), (65,55)\}$. Then, the amplified signal is transmitted by a collimating lens RC04APC-P01. The first FSO transmission distance is 1.8 m, and the weak and moderate turbulence effects are simulated by the turbulence template. To simulate the signal attenuation of the first and second FSO links, the tunable attenuators FVA-600 are used respectively. The relay has a collimating lens for receiving the optical signal, and another collimating lens for transmitting the optical signal. At the DF relaying node, a matched decoder is used for decoding, and the data is recovered after EDFA amplification and 18.5-ps IR PD (photodetector). Then, the signal is encoded by two-dimensional optical encoder and transmitted in the second FSO link. The transmission length is also 1.8 m. Similarly, the weak and moderate turbulence effects

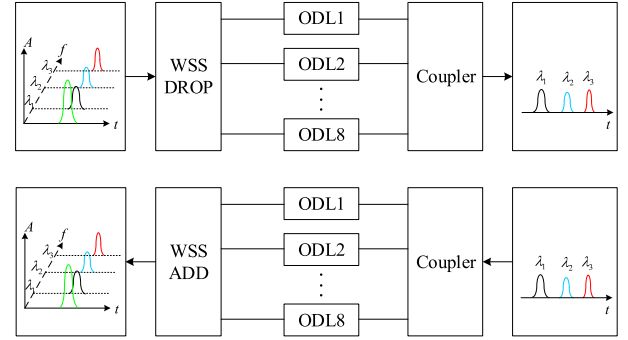

Fig. 2. Two-dimensional optical encoder/decoder.

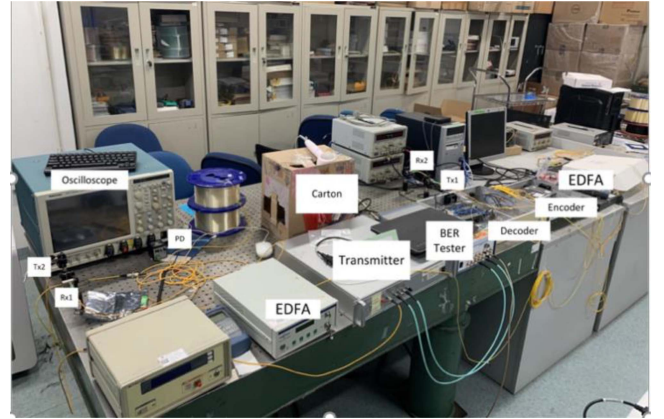

Fig. 3. Experiment setup.

are simulated by the turbulence template. At the receiver, the matched decoder is used for decoding, and the data is recovered after EDFA amplification and PD detection.

Fig. 1(b) is the 10 Gb/s AF relaying FSO-CDMA experimental system. The difference between them is that the relay node uses all-optical amplification by EDFA-MW-BA-40-16-16. The BER is tested by SeBERT-10G, and the eye diagram is observed by Tektronix DPO 72004C. To compare the performance of DF and AF relaying systems, the FSO links of both systems have the same turbulence effects.

Fig. 2 shows the structure of two-dimensional optical encoder/decoder. In the experiment, we use ports 2, 5 and 6 of WSS, which are corresponding to wavelengths 1549.72 nm, 1550.12 nm and 1550.52 nm respectively. In the encoder, the delays of ODL2, ODL5 and ODL6 are 7.1 ps, 30.2 ps, and 37.9 ps. In the decoder, and delays of ODL2, ODL5 and ODL6 are 92.9 ps, 69.8 ps, and 62.1 ps respectively.

Fig. 3 shows the experimental setup, in which a carton is used to simulate weak and moderate turbulence conditions by controlling different wind temperatures and speeds [17]. The corresponding sampling waveforms under different turbulences are shown in Fig. 4.

Then, we can calculate the turbulence situation. The variance is achieved by $\sigma_I^2 = \frac{\langle I_1^2 \rangle}{\langle I_1 \rangle^2} - 1$, where I_1 is the signal intensity. Then, according to the equation $\sigma_I^2 = 1.23 \left(\frac{2\pi}{\lambda} \right)^7 C_n^2 d_i^{\frac{11}{6}}$, we

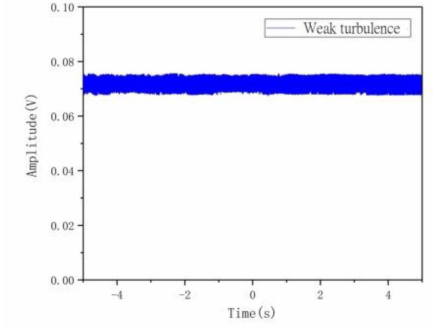

(a) Weak turbulence

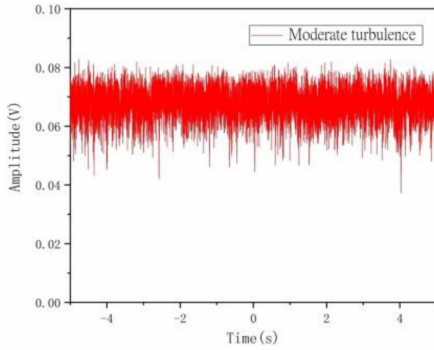

(b) Moderate turbulence

Fig. 4. The corresponding sampling waveforms under different turbulences.

can get the refractive index structure coefficient C_n^2 . Here, λ is the wavelength, and d_i is the transmission distance. In the experiment, we get $C_n^2 = 4.96 \times 10^{-15} \text{m}^{-2/3}$ and $C_n^2 = 3.41 \times 10^{-14} \text{m}^{-2/3}$, which are weak turbulence and moderate turbulence respectively. In the experiment, since the distance to be covered is only 1.8 m, the variance is much less than 0.1. However, the optical coding system is more sensitive to intensity fluctuations than the uncoded system.

In the AF relaying FSO-CDMA experimental system, the transmitting power of the first FSO link is 5 dBm and the receiving power is -1 dBm. By adjusting the EDFA gain factor, the transmitting power of the second FSO link can vary from 0.4 dBm to 3.6 dBm. Accordingly, the receiving power varies from -5.6 dBm to -2.4 dBm. In this case, BER can be measured in weak and moderate turbulence respectively.

In the DF relaying FSO-CDMA experimental system, the transmitting power of the first FSO link is 5 dBm and the receiving power is -1 dBm. In this case, BER of the first FSO link (P_{SR}) can be measured in weak and moderate turbulence respectively. In order to have the same system parameters as the AF relaying system, the transmitting power of the second FSO link also varies from 0.4 dBm to 3.6 dBm, and the receiving power varies from -5.6 dBm to -2.4 dBm accordingly. In this case, BER of the second FSO link (P_{RD}) can be measured in weak and moderate turbulence respectively. Then, we can obtain the BER of DF relaying FSO-CDMA experimental system, which is expressed as $P_e = 1 - (1 - P_{SR})(1 - P_{RD})$.

The impact of turbulence on eye diagrams of AF relaying FSO-CDMA is shown in Fig. 5. The receiving power is -4 dBm.

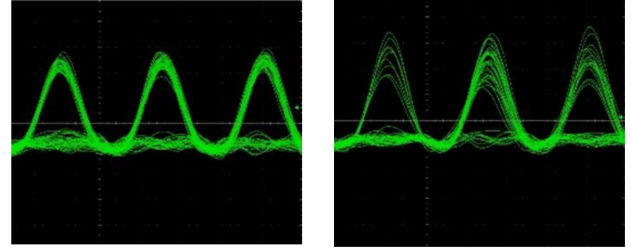

(a) Weak turbulence

(b) Moderate turbulence

Fig. 5. Eye diagrams of single-user AF relaying FSO-CDMA.

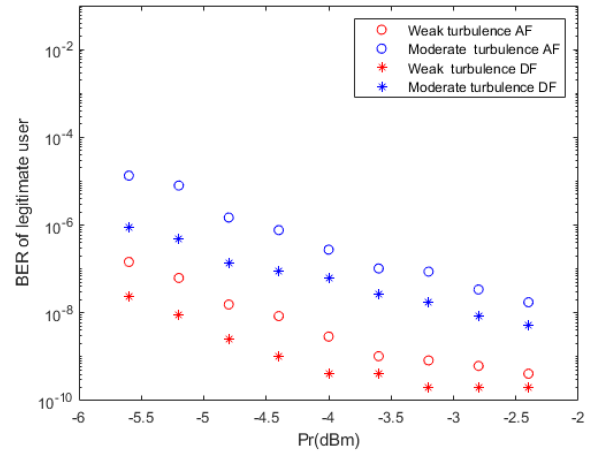

Fig. 6. BERs of single-user AF and DF relaying FSO-CDMA system (transmitting power 5 dBm).

As the turbulence effect increases, the fluctuation of received signal intensity becomes more obvious, which leads to the deterioration of eye diagram.

Fig. 6 shows BERs of single-user AF and DF relaying FSO-CDMA at transmitting power 5 dBm. With the increase of the receiving power of the second link, BERs of AF and DF systems also decrease significantly. In the same relay mode, the BER of weak turbulence is significantly lower than that of moderate turbulence. The reason is that, with the enhancement of turbulence effect, fluctuation of signal intensity will be more obvious. On the other hand, the BER of DF system is lower than that of AF system. The reason is that, at the relaying node of AF system, the background noise and the amplified spontaneous emission noise of EDFA will deteriorate the optical signal-to-noise (SNR). However, the performance gap is decreasing with the increase of receiving power. Under weak turbulence, at the receiving power -5.6 dBm, BERs of AF and DF relaying systems are 1.45E-7 and 2.38E-8 respectively, while at the receiving power -2.4 dBm, BERs of AF and DF relaying systems are 4.13E-10 and 2.06E-10 respectively. Under moderate turbulence, at the receiving power -5.6 dBm, BERs of AF and DF relaying systems are 1.34E-5 and 8.78E-7 respectively, while at the receiving power -2.4 dBm, BERs of AF and DF relaying systems are 1.75E-8 and 5.39E-9 respectively.

Fig. 7 shows BERs of single-user AF and DF relaying FSO-CDMA when the transmitting power of the first FSO link is 3.2 dBm. The transmitting power of the second FSO link varies

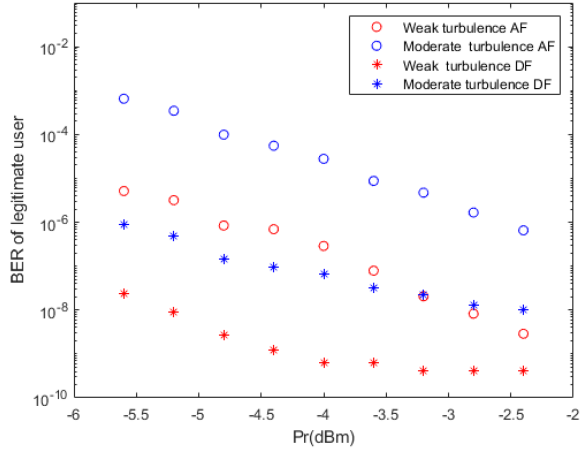

Fig. 7. BERs of single-user AF and DF relaying FSO-CDMA system (transmitting power 3.2 dBm).

from 0.4 dBm to 3.6 dBm. Correspondingly, the receiving power varies from -5.6 dBm to -2.4 dBm. Similar to the results in Fig. 6, the BER of DF system is lower than that of AF system, and the performance gap is decreasing with the increase of receiving power. Under weak turbulence, at the receiving power -5.6 dBm, BERs of AF and DF relaying systems are $5.14\text{E-}6$ and $2.40\text{E-}8$ respectively, while at the receiving power -2.4 dBm, BERs of AF and DF relaying systems are $2.89\text{E-}9$ and $4.1\text{E-}10$ respectively. Under moderate turbulence, at the receiving power -5.6 dBm, BERs of AF and DF relaying systems are $6.52\text{E-}4$ and $8.82\text{E-}7$ respectively, while at the receiving power -2.4 dBm, BERs of AF and DF relaying systems are $6.55\text{E-}7$ and $9.93\text{E-}9$ respectively.

Compared with Fig. 6, the BER increases at the same receiving power, due to the decrease of the transmitting power of the first link. Particularly, when the receiving power is lower than -3.2 dBm, the BER of the DF relaying FSO-CDMA system under moderate turbulence is lower than that of the AF relaying FSO-CDMA system under weak turbulence. This also shows that when the SNR is lower, the performance improvement of the DF relaying FSO-CDMA system is more obvious than that of the AF relaying FSO-CDMA system.

III. TWO-USER EXPERIMENTAL SYSTEM

Fig. 8 shows 10 Gb/s two-user DF relaying FSO-CDMA and AF relaying FSO-CDMA experimental systems. Encoder 1 is two-dimensional optical encoder, which is used in Fig. 1. Encoder 2 is one-dimensional optical encoder, which is composed of couplers and tunable optical delay lines (TODL), as Fig. 9 shows. In the encoder, the delays of TODL are 14.3 ps, 28.6 ps, 71.4 ps. In the decoder, the delays of TODL are 85.7 ps, 71.4 ps and 28.6 ps, respectively [17].

Fig. 10 shows BERs of two-user AF relaying FSO-CDMA and DF relaying FSO-CDMA at the transmitting power 5 dBm. Under the same relay mode, the BER of moderate turbulence is higher than that of weak turbulence due to different turbulence effects. On the other hand, BER of DF relaying system is lower

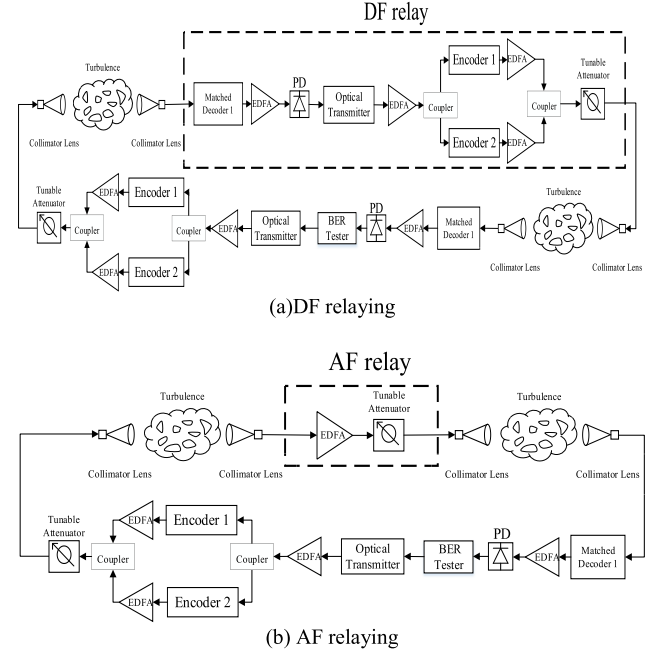

Fig. 8. 10 Gb/s two-user DF relaying FSO-CDMA and AF relaying FSO-CDMA experimental systems.

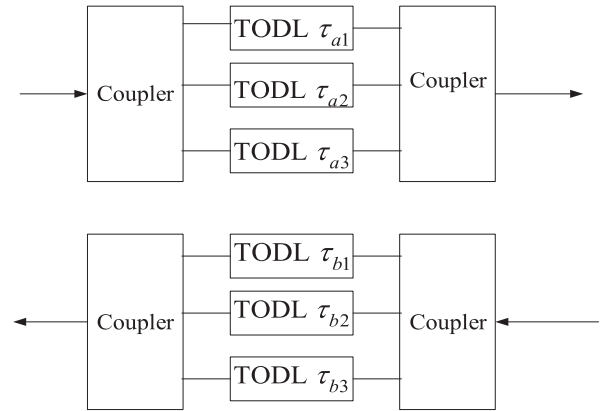

Fig. 9. One-dimensional optical encoder/decoder.

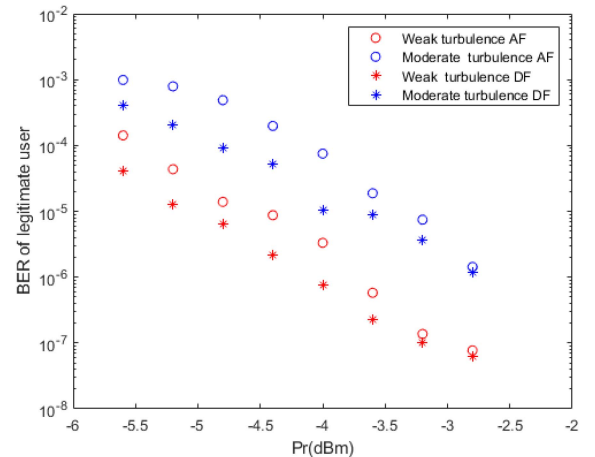

Fig. 10. BERs of two-user AF and DF relaying FSO-CDMA systems (transmitting power 5 dBm).

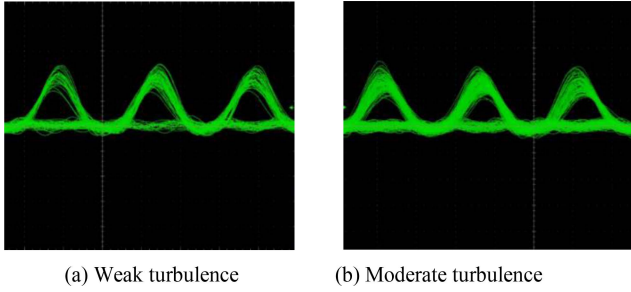

Fig. 11. Eye diagrams of two-user AF relaying FSO-CDMA system.

than that of AF relaying system, especially at low receiving power. Compared with the results of single-user relaying FSO-CDMA system, BER of two-user relaying system increases significantly. The reason is that different codes can cause multiple access interference (MAI).

Compared with Fig. 6, the performance gap of AF relaying FSO-CDMA and DF relaying FSO-CDMA is decreasing more quickly with the increase of receiving power. At the receiving power -2.8 dBm, AF relaying FSO-CDMA and DF relaying FSO-CDMA have almost the same BER performances. In the system design, if the relay distance is short or the SNR is high, the AF relaying FSO-CDMA system can be used. In this case, the system performance of the two systems is comparable, but the complexity of the DF relaying system is relatively simple. On the contrary, if the relay distance is long or the SNR is low, the DF relaying FSO-CDMA system should be employed.

Fig. 11 shows eye diagrams of two-user AF relaying FSO-CDMA system. The receiving power is -4 dBm. As the turbulence effect increases, the fluctuation of received signal intensity becomes more obvious, which leads to the deterioration of eye diagrams.

Based on the binary symmetric channel model [22], channel capacity (bit/symbol) can be calculated as

$$C = 1 - [-(1 - P_b) \log_2(1 - P_b) - P_b \log_2 P_b] \quad (1)$$

where P_b is the measured BER. Fig. 12 shows channel capacities of two-user AF relaying FSO-CDMA and DF relaying FSO-CDMA at the transmitting power 5 dBm. Under the same relay mode, the channel capacity of moderate turbulence is lower than that of weak turbulence due to different turbulence effects. On the other hand, the channel capacity of DF relaying system is higher than that of AF relaying system, especially at low receiving power.

IV. PHYSICAL LAYER SECURITY

Fig. 13 shows the experimental system of physical layer security in two-user AF relaying FSO-CDMA. Due to the beam spreading, Eve can eavesdrop on the laser beam area behind the legitimate user. According to Kerckhoffs's principle, Eve cannot know exactly which code the legitimate user is using. Therefore, Eve can only use a random decoder. As discussed in [16], Eve can only obtain very small receiving power in order not to be noticed by the legitimate user. Here, we assume that the eavesdropping

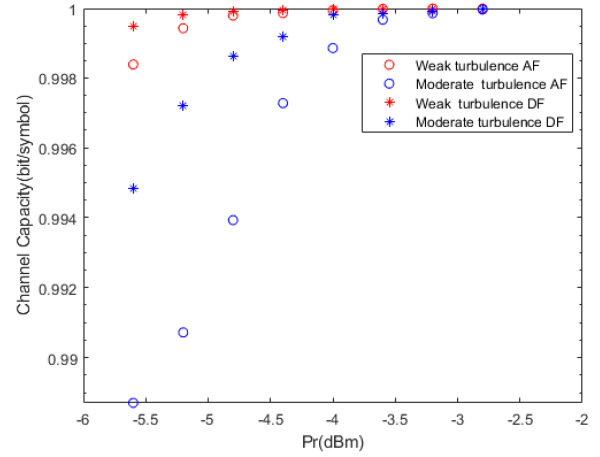

Fig. 12. Channel capacities of two-user AF and DF relaying FSO-CDMA systems (transmitting power 5 dBm).

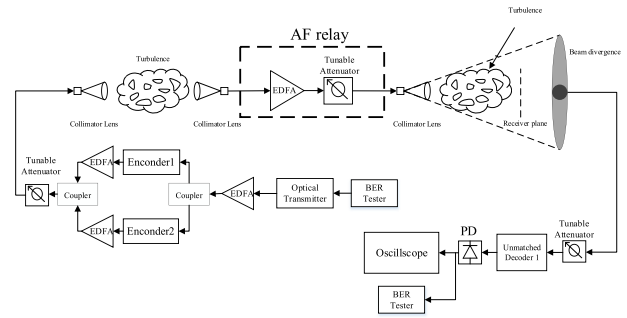

Fig. 13. Experimental system of physical layer security in two-user AF relaying FSO-CDMA.

ratio is 1% [16]. At the receiver, the tunable attenuator is used to simulate the attenuation of the receiving power. After an unmatched decoder, the decoded signal is detected by 18.5-ps IR PD. Then, the eye diagram can be observed by Tektronix DPO 72004C and BER can be measured by SeBERT-10G.

Under both weak and moderate turbulence conditions, at the receiving power -2.8 dBm, the measured BERs exceed 0.1, which will be larger than the BER threshold (0.02) of soft-decision forward error correction code [23]. At this time, Eve cannot intercept the user information correctly. Therefore, physical layer security can be achieved by relaying FSO-CDMA scheme. It should be pointed out that, for the single-user relaying FSO-CDMA system, Eve can use the eavesdropping method of energy detection. At this point, Eve can correctly obtain user information without a matched decoder. Therefore, the single-user relaying FSO-CDMA system has no physical layer security.

V. CONCLUSION

In this paper, under two different turbulence conditions, we have designed and investigated the 10 Gb/s AF relaying FSO-CDMA and DF relaying FSO-CDMA experimental systems. To be best of authors' knowledge, this is the first demonstration and

comparison of the AF relaying FSO-CDMA and DF relaying FSO-CDMA system. It is shown that when the receiving power is low, BER of DF relaying FSO-CDMA is one to two orders of magnitude lower than that of AF relaying FSO-CDMA. However, as the receiving power increases, the performance gap between DF and AF relaying gradually decreases. When the receiving power is -2.8 dBm, two-user AF and DF relaying FSO-CDMA systems have almost the same BER performance. Therefore, we can design different relaying schemes according to different relay distance or receiving power. Another advantage is that the physical layer security of the relaying FSO system can be achieved by the optical coding scheme. Moreover, the optical coding scheme can realize multi-user relaying FSO communication systems.

REFERENCES

- [1] M. A. Khalighi and M. Uysal, "Survey on free space optical communication: A communication theory perspective," *IEEE Commun. Surv. Tut.*, vol. 16, no. 4, pp. 2231–2258, Oct.–Dec. 2014.
- [2] M. Uysal, J. Li, and M. Yu, "Error rate performance analysis of coded free-space optical links over gamma-gamma atmospheric turbulence channels," *IEEE Trans. Wireless Commun.*, vol. 5, no. 6, pp. 1229–1233, Jun. 2006.
- [3] S. M. Navidpour, M. Uysal, and M. Kavehrad, "BER performance of free space optical transmission with spatial diversity," *IEEE Trans. Wireless Commun.*, vol. 6, no. 8, pp. 2813–2819, Aug. 2007.
- [4] L. Yang, X. Gao, and M.-S. Alouini, "Performance analysis of relay-assisted all-optical FSO networks over strong atmospheric turbulence channels with pointing errors," *J. Lightw. Technol.*, vol. 32, no. 23, pp. 4613–4620, Dec. 2014.
- [5] S. Kazemlou, S. Hranilovic, and S. Kumar, "All-optical multihop free-space optical communication systems," *J. Lightw. Technol.*, vol. 29, no. 18, pp. 2663–2669, Sep. 2011.
- [6] M. A. Kashani, M. M. Rad, M. Safari, and M. Uysal, "All-optical amplify-and-forward relaying system for atmospheric channels," *IEEE Commun. Lett.*, vol. 16, no. 10, pp. 1684–1687, Oct. 2012.
- [7] M. T. Dabiri and S. M. S. Sadough, "Performance analysis of all-optical amplify and forward relaying over log-normal FSO channels," *IEEE/OSA J. Opt. Commun. Netw.*, vol. 10, no. 2, pp. 79–89, Feb. 2018.
- [8] P. V. Trinh, N. T. Dang, and A. T. Pham, "All-optical relaying FSO systems using EDFA combined with optical hard-limiter over atmospheric turbulence channels," *J. Lightw. Technol.*, vol. 33, no. 19, pp. 4132–4144, Oct. 2015.
- [9] E. Bayaki, D. S. Michalopoulos, and R. Schober, "EDFA-based all-optical relaying in free-space optical systems," *IEEE Trans. Commun.*, vol. 60, no. 12, pp. 3797–3807, Dec. 2012.
- [10] N. A. M. Nor et al., "Experimental investigation of all-optical relay-assisted 10 Gb/s FSO link over the atmospheric turbulence channel," *J. Lightw. Technol.*, vol. 35, no. 1, pp. 45–53, Jan. 2017.
- [11] J. Libich, M. Komanec, S. Zvanovec, P. Pesek, W. O. Popoola, and Z. Ghassemlooy, "Experimental verification of an all-optical dual-hop 10 Gbit/s free-space optics link under turbulence regimes," *Opt. Lett.*, vol. 40, no. 3, pp. 391–394, 2015.
- [12] M. Safari and M. Uysal, "Relay-assisted free-space optical communication," *IEEE Trans. Wireless Commun.*, vol. 7, no. 12, pp. 5441–5449, Dec. 2008.
- [13] T. A. Tsiftsis, H. G. Sandalidis, G. K. Karagiannidis, and N. C. Sagias, "Multihop free-space optical communications over strong turbulence channels," in *Proc. IEEE Int. Conf. Commun.*, 2006, pp. 2755–2759.
- [14] B. Ashrafzadeh, A. Zaimbashi, and E. Soleimani-Nasab, "A framework on the performance analysis of relay-assisted FSO transmission systems," *Opt. Commun.*, vol. 450, pp. 352–365, 2019.
- [15] D. Zou and Z. Xu, "Information security risks outside the laser beam in terrestrial free-space optical communication," *IEEE Photon. J.*, vol. 8, no. 5, Oct. 2016, Art. no. 7804809.
- [16] F. J. Lopez-Martinez, G. Gomez, and J. M. Garrido-Balsells, "Physical-layer security in free-space optical communications," *IEEE Photon. J.*, vol. 7, no. 2, Apr. 2015, Art. no. 7901014.
- [17] J. Ji, B. Wu, J. Zhang, M. Xu, and K. Wang, "Design and investigation of 10 Gb/s FSO wiretap channel using OCDMA time-diversity reception," *IEEE Photon. J.*, vol. 12, no. 3, Jun. 2020, Art. no. 7903212.
- [18] H. T. T. Pham, P. V. Trinh, N. T. Dang, and A. T. Pham, "Secured relay-assisted atmospheric optical code-division multiple-access systems over turbulence channels," *IET Optoelectron.*, vol. 9, no. 5, pp. 241–248, Jun. 2015.
- [19] M. V. Jamali, F. Akhondi, and J. A. Salehi, "Performance characterization of relay-assisted wireless optical CDMA networks in turbulent underwater channel," *IEEE Trans. Wireless Commun.*, vol. 15, no. 6, pp. 4104–4116, Jun. 2016.
- [20] P. Ouyang, J. Ji, K. Wang, and M. Xu, "Performance analysis of EDFA-based all-optical relaying FSO-CDMA wiretap channel," in *Proc. Int. Academic Exchange Conf. Sci. Technol. Innov.*, 2021, pp. 1–5.
- [21] P. Ouyang, J. Ji, M. Liu, K. Wang, M. Xu, and Y. Song, "Design and investigation of EDFA-based all-optical relaying FSO-CDMA wiretap channel," *Opt. Quantum Electron.*, vol. 54, no. 7, Jun. 2022, Art. no. 444.
- [22] V. A. Vilnrotter and C. W. Lau, "Quantum detection and channel capacity for communications applications," *Proc. SPIE*, vol. 4635, pp. 103–115, Apr. 2002.
- [23] X. Li, Y. Xu, and J. Yu, "Over 100-Gb/s V-Band single-carrier PDM-64QAM fiber-wireless-integration system," *IEEE Photon. J.*, vol. 8, no. 5, Oct. 2016, Art. no. 7906907.