

# A 20-m/40-Gb/s 1550-nm DFB LD-Based FSO Link

Volume 7, Number 6, December 2015

Wen-Shing Tsai  
Hai-Han Lu, Senior Member, IEEE  
Chung-Yi Li  
Ting-Chieh Lu  
Chen-Hong Liao  
Chien-An Chu  
Peng-Chun Peng

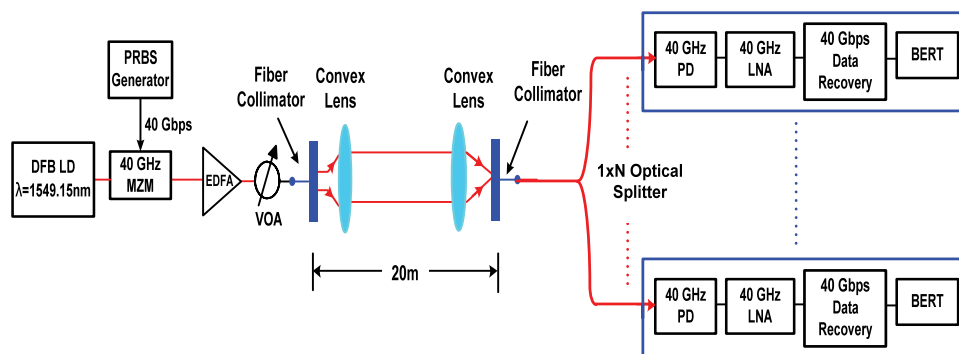

DOI: 10.1109/JPHOT.2015.2506172  
1943-0655 © 2015 IEEE

# A 20-m/40-Gb/s 1550-nm DFB LD-Based FSO Link

Wen-Shing Tsai,<sup>1</sup> Hai-Han Lu,<sup>2</sup> *Senior Member, IEEE*,  
Chung-Yi Li,<sup>2</sup> Ting-Chieh Lu,<sup>2</sup> Chen-Hong Liao,<sup>1</sup>  
Chien-An Chu,<sup>2</sup> and Peng-Chun Peng<sup>2</sup>

<sup>1</sup>Department of Electrical Engineering, Ming Chi University of Technology,  
New Taipei City 24301, Taiwan

<sup>2</sup>Institute of Electro-Optical Engineering, National Taipei University of Technology,  
Taipei 10608, Taiwan

DOI: 10.1109/JPHOT.2015.2506172

1943-0655 © 2015 IEEE. Translations and content mining are permitted for academic research only.  
Personal use is also permitted, but republication/redistribution requires IEEE permission.  
See [http://www.ieee.org/publications\\_standards/publications/rights/index.html](http://www.ieee.org/publications_standards/publications/rights/index.html) for more information.

Manuscript received November 7, 2015; revised November 30, 2015; accepted December 2, 2015.  
Date of publication December 7, 2015; date of current version December 18, 2015. Corresponding  
author: H.-H. Lu (e-mail: hllu@ntut.edu.tw).

**Abstract:** An innovative free-space optical (FSO) link using laser light propagation to achieve transmission rate of 40 Gb/s at a wavelength of 1550 nm is proposed and experimentally demonstrated. Over a 20-m free-space link, brilliant bit-error-rate performance and clear eye diagram are obtained in the proposed 1550-nm distributed feedback (DFB) laser diode (LD)-based FSO links. As far as we know, it is the first time that a 1550-nm externally modulated laser transmitter cascaded with an erbium-doped fiber amplifier and a pair of fiber collimators to successfully set up a 20-m/40-Gb/s FSO link has been employed. Compared with the 680-nm vertical-cavity surface-emitting laser-based FSO link, this proposed 1550-nm DFB LD-based FSO link is attractive not only because it has longer free-space transmission distance but because it supplies higher bandwidth operation as well. Such a 1550-nm DFB LD-based FSO link provides the benefits of optical wireless communications for longer transmission distance and higher transmission rate, which is thoroughly helpful for optical wireless network applications.

**Index Terms:** Fiber collimator, free-space optical link, optical wireless communications.

## 1. Introduction

The main characteristics of free-space optical (FSO) links are high directivity, which provides high power efficiency and isolation from other interferences, unlicensed bandwidth, easy installation, and the promise of multi-gigabit mobile applications by using flexibility through free-space links [1]–[6]. An FSO link, by which using laser light propagation in free-space to deliver high quality signal and high-speed data rate, is therefore developed with high expectation to conquer the wireless connection issues. The FSO link has attracted a lot of attention as a potential candidate for optical wireless communications because it has several advantages over the traditional radio frequency (RF)-based wireless communications. For a real and practical implementation of FSO link, long free-space transmission distance and high free-space transmission rate are the major concerns of system engineers and designers. A 10 m/25, Gb/s two-stage, injection-locked 680-nm vertical-cavity surface-emitting laser (VCSEL)-based light-based WiFi (LiFi) transmission system was demonstrated previously [7], [8]. However, sophisticated two-stage injection locking technique is required, and it will increase the complexity of LiFi

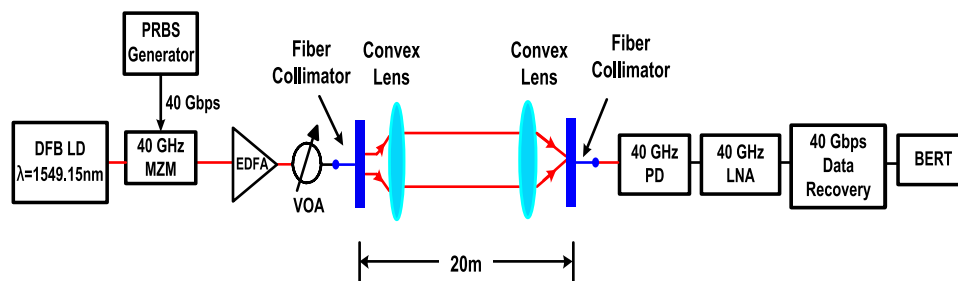

Fig. 1. Experimental configuration of the proposed 20 m/40 Gb/s FSO links which employ a 1550-nm externally modulated laser transmitter cascaded with an EDFA and a pair of fiber collimators.

transmission systems. Moreover, it is difficult to obtain good free-space transmission performance due to modal noise induced from the multi-mode VCSEL. The free-space transmission distance and transmission rate can be further improved by 1550-nm distributed feedback (DFB) laser diode (LD)-based FSO links. To compare with the two-stage injection-locked 680-nm VCSEL-based FSO link, the 1550-nm DFB LD-based FSO link is attractive not only to have higher optical power launched into the free-space, but also to provide larger bandwidth operation to FSO links. In this paper, a 20 m/40 Gb/s 1550-nm DFB LD-based FSO link is proposed. We successfully demonstrate that a 40-Gb/s data stream can be transmitted to a 20-m free-space link. To the best of our knowledge, it is the first one that employs a 1550-nm externally modulated laser transmitter cascaded with an erbium-doped fiber amplifier (EDFA) and a pair of fiber collimators to establish a 20 m/40 Gb/s FSO link successfully. Over a 20-m free-space link, good bit error rate (BER) performance and a clear eye diagram are achieved in the proposed 1550-nm DFB LD-based FSO links with a transmission rate of 40 Gb/s.

## 2. Experimental Setup

Fig. 1 depicts the experimental configuration of the proposed 20 m/40 Gb/s FSO links which employ a 1550-nm externally modulated laser transmitter cascaded with an EDFA and a pair of fiber collimators. The DFB LD with a central wavelength of 1549.15 nm provides an optical carrier to a Mach–Zehnder modulator (MZM) with a 3-dB bandwidth of 40 GHz. The MZM is modulated by a 40-Gb/s pseudorandom binary sequence (PRBS) of  $2^{15} - 1$  generated by a PRBS generator, and the modulation scheme is on-off keying directly from PRBS sequence. For achieving modulation in intensity, the MZM is operated at the quadrature point. The output power and noise figure of EDFA are 17 dBm and 4.5 dB at an input power of 0 dBm, respectively. A variable optical attenuator (VOA) is positioned at the start of the EDFA so that the optical power launched into the free-space can be optimized to obtain the best transmission performance. Since 1550 nm light suffers from less free-space attenuation than 680/785/830 nm light [9], [10], the wavelength of 1550 nm is selected in a FSO link. Furthermore, EDFA can only amplify optical signals in the 1550 nm region, and thereby a FSO link can be enhanced by the introduction of 1550 nm technology. A pair of fiber collimators is used to collimate light from a fiber to form a collimated optical beam and to couple light from free-space into an optical fiber. The fiber collimators connected to single-mode fibers (SMFs) play an important role in forming an optical beam for delivering optical signal through the free-space between the two sides. The fiber collimator has an operating wavelength range of 1050–1620 nm, a fiber-to-lens distance of 7.5 mm, a divergence of  $0.079^\circ$ , and a focal length of 7.5 mm. The light emitted from the first-stage fiber collimator is fed into the first-stage convex lens, transmitted in the free-space, inputted into the second-stage convex lens, and concentrated on the second-stage fiber collimator. Over a 20-m free-space link, the optical signal is detected by a 40-GHz photodiode (PD) with a responsivity of 0.55 mA/mW (at 1550 nm) and amplified by a 40-GHz low noise amplifier (LNA) with a 3-dB bandwidth of 40 GHz and a small signal gain of

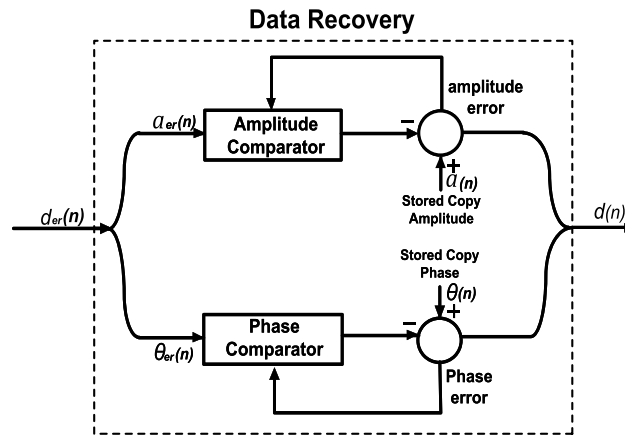

Fig. 2. Functional block diagram of the data recovery.

20 dB (measured at 40 GHz). It is necessary for an LNA to amplify the data stream while adding as little noise and distortion as possible. After LNA amplification, the data stream is recovered by a 40-Gb/s data recovery scheme, and fed into a bit error rate tester (BERT) for BER performance evaluation. The function of the data recovery is to recover and regenerate the data stream from the distorted data stream due to a 20-m free-space link.

### 3. Experimental Results and Discussion

The modulation bandwidth of the two-stage injection-locked 680-nm VCSEL-based LiFi transmission systems is 26.2 GHz [7]. As to the modulation bandwidth of the 1550-nm DFB LD-based FSO links, it is crucially determined by the modulation bandwidth of MZM employed in FSO links. In this work, the modulation bandwidth of the 1550-nm DFB LD-based FSO links can be increased to 40 GHz due to the use of 40 GHz MZM. This finding shows that the 1550-nm externally modulated laser transmitter is powerful enough for 40 Gb/s transmission. However, the transmission rate can be further enhanced by employing a MZM with a 3-dB bandwidth larger than 40 GHz. Moreover, multi-mode VCSEL often introduces modal noise in systems and results in the deterioration of transmission performance. It can be improved by replacing the multi-mode VCSEL-based LiFi transmission systems with single-mode DFB LD-based FSO links to remove the modal noise. Furthermore, the free-space transmission distance of the two-stage injection-locked 680-nm VCSEL-based LiFi transmission systems is 10 m [7]. As to the free-space transmission distance of the 1550-nm DFB LD-based FSO links, it is mainly determined by the output optical power of EDFA employed in FSO links. In this work, the transmission distance of the 1550-nm DFB LD-based FSO links is extended to 20 m due to the use of 17 dBm EDFA. However, the transmission distance can be further increased by employing an EDFA with an optical power higher than 17 dBm.

A functional block diagram of the data recovery is illustrated in Fig. 2, by which including amplitude and phase comparators. The distorted data signal goes into the data recovery and separates into two distinct paths. One passes through the amplitude comparison path while the other passes through the phase comparison path. These two distinct paths are employed to implement a successful data recovery in a long-distance and high-speed FSO link. If a data signal  $d(n)$  without distortion is available at the transmitting site, then a distorted data signal  $d_{er}(n)$  due to a 20-m free-space link is received at the receiving site. Here,  $n$  is the  $n$ th number,  $d(n)$  is the  $n$ th data signal of the data stream, and  $d(n)$  can be bit 1 or bit 0. The data signal  $d(n)$  has an amplitude  $a(n)$  and a phase  $\theta(n)$

$$d(n) = a(n)e^{j\theta(n)}. \quad (1)$$

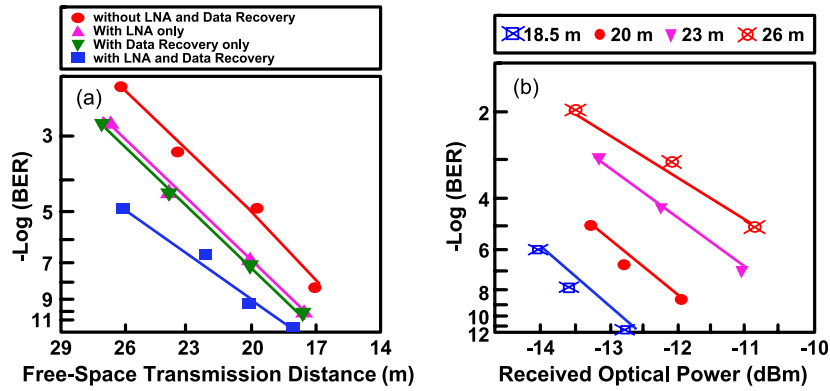

Fig. 3. Measured BER curves of the 1550-nm DFB LD-based FSO links at a data stream of 40 Gb/s (a) without/with LNA/data recovery and (b) over 18.5 m/20 m/23 m/26 m free-space link scenarios (with LNA and data recovery).

Over a 20-m free-space link, the received distorted data signal  $d_{er}(n)$  has a distorted amplitude  $a_{er}(n)$  and a distorted phase  $\theta_{er}(n)$

$$d_{er}(n) = a_{er}(n)e^{j\theta_{er}(n)}. \quad (2)$$

The function of the data recovery is to recover  $d(n)$  from  $d_{er}(n)$ . For amplitude comparison, the output of the amplitude comparator is compared with the stored copy of  $a(n)$ , the amplitude comparator has to obtain  $a(n)$  from  $a_{er}(n)$ . For phase comparison, the output of the phase comparator is compared with the stored copy of  $\theta(n)$ , the phase comparator has to obtain  $\theta(n)$  from  $\theta_{er}(n)$ . And thereby, the data signal  $d(n)$  is recovered from the distorted data signal  $d_{er}(n)$ . Fast feedback updates the amplitude and phase errors so that the errors are deleted to recover the data signal  $d(n)$ .

The measured BER curves of the 1550-nm DFB LD-based FSO links at a data stream of 40 Gb/s are shown in Fig. 3(a). At a free-space transmission distance of 20 m, as LNA and data recovery are not employed, the BER is around  $10^{-5}$ . However, as LNA and data recovery are employed concurrently, the BER reaches about  $10^{-9}$ . A great BER performance improvement ( $10^{-5} \rightarrow 10^{-9}$ ) is achieved. Brilliant BER performance is obtained to demonstrate the feasibility of building up a 20 m/40 Gb/s FSO link. To have a more association with LNA, data recovery, and BER performance, we remove one of the BER performance improvement schemes. It is obvious that as only one BER performance improvement scheme is employed, the BER performance improvement is limited ( $10^{-5} \rightarrow 10^{-7}$ ). Both of the LNA and data recovery play important roles for error corrections. They can ameliorate the signal-to-noise ratio (SNR) value of FSO links, by which leading to BER performance improvement. In addition, the measured BER curves of the 1550-nm DFB LD-based FSO links at a data stream of 40 Gb/s over 18.5 m/20 m/23 m/26 m free-space link scenarios, as LNA and data recovery are employed simultaneously, are shown in Fig. 3(b). It is obvious that as the free-space transmission distance increases the BER value increases as well. Longer free-space transmission distance leads to lower received optical power level and results in the degradation of BER performance. For an FSO link, there is a trade-off between the transmission distance and the transmission rate. Error-free operation can be achieved under different transmission distance with different transmission rate. Therefore, different transmission distance and transmission rate can be achieved in accordance with the requirement of FSO links. Moreover, in Fig. 3(b), we illustrate the BER performance with respect to received optical power. The received optical power means the optical power received at the PD. It can be seen that when the received optical power for each curve is the same as others, the BER performance is different. This is because the received optical power

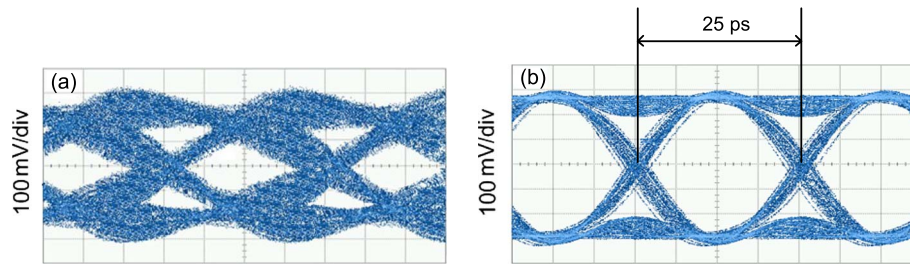

Fig. 4. Eye diagrams of the 40 Gb/s data stream over a 20-m free-space link (a) without employing LNA and data recovery and (b) with employing LNA and data recovery concurrently.

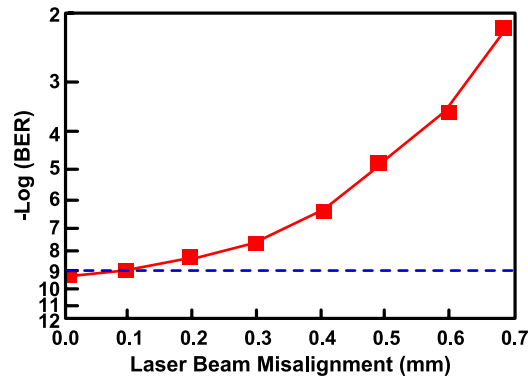

Fig. 5. BER values of a 20 m/40 Gb/s FSO link with LNA and data recovery under different laser beam misalignments.

also includes other distortion light. As the free-space transmission distance increases, the received optical SNR decreases and results in worse BER performance.

The eye diagrams of the 40 Gb/s data stream over a 20-m free-space link without/with employing LNA and data recovery are displayed in Fig. 4(a) and (b), respectively. Amplitude and phase variations obviously occur (see Fig. 4(a)) as LNA and data recovery are not employed. However, as LNA and data recovery are employed concurrently, a clear eye diagram (see Fig. 4(b)) is observed due to the suppression of amplitude and phase variations.

The FSO link is to realize the free-space transmission using a pair of fiber collimators with SMFs. Propagating a laser beam through the free-space between the fiber collimators enacts the FSO links to work as if the fibers were connected seamlessly. Laser beam alignment and beam radius size between two fiber collimators are critical for the transmission performance of an FSO link [11], [12]. An FSO link with laser beam misalignment and divergent beam radius will degrade the transmission performance. To measure the BER values of a 20 m/40 Gb/s FSO link with LNA and data recovery under different laser beam misalignments, the results are given in Fig. 5. It is clear that as the misalignment increases the BER value increases as well. An error-free operation of  $10^{-9}$  can be achieved when the laser beam misalignment is smaller than 0.1 mm. In addition, the BER values of a 20 m/40 Gb/s FSO link with LNA and data recovery under different beam radii is present in Fig. 6. It is obvious that as the beam radius increases the BER value increases as well. An error-free operation of  $10^{-9}$  can be obtained as the beam radius is smaller than 0.3 mm.

By employing a  $1 \times N$  optical splitter at the receiving site (as shown in Fig. 7), we can apply the collimated laser communication for supporting the broadcasting nature of optical wireless access. Such a 20 m/40 Gb/s 1550-nm DFB LD-based FSO link provides the advantages of long-distance and high-speed LiFi transmission. A 20 m/40 Gb/s LiFi transmission system is highly useful for optical wireless communications.

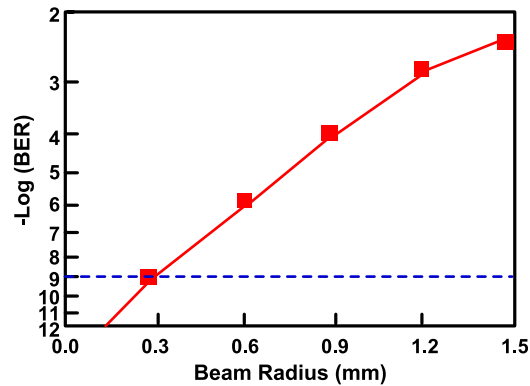

Fig. 6. BER values of a 20 m/40 Gb/s FSO link with LNA and data recovery under different beam radii.

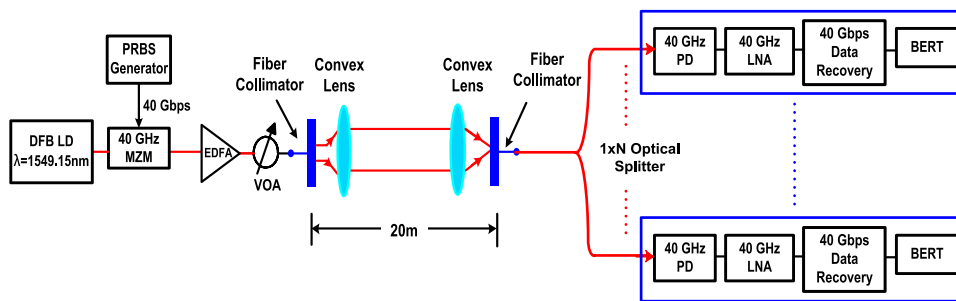

Fig. 7. A 20 m/40 Gb/s LiFi transmission system.

#### 4. Conclusion

A 20 m/40 Gb/s FSO link based on a 1550-nm externally modulated laser transmitter cascaded with an EDFA and a pair of fiber collimators is proposed and experimentally demonstrated. Through a thorough investigation, good BER operation and clear eye diagram are achieved in the proposed 20 m/40 Gb/s 1550-nm DFB LD-based FSO link. Such an innovative FSO link is attractive not only to demonstrate its enhancement in the optical wireless communications, but also to provide the advantages of a communication link for longer free-space transmission distance and higher free-space transmission rate.

#### References

- [1] R. Boluda-Ruiz, A. García-Zambrana, B. Castillo-Vázquez, and C. Castillo-Vázquez, "Impact of relay placement on diversity order in adaptive selective DF relay-assisted FSO communications," *Opt. Exp.*, vol. 23, no. 2, pp. 2600–2617, Feb. 2015.
- [2] C. L. Ying *et al.*, "A bidirectional hybrid lightwave transport system based on fiber-IVLLC and fiber-VLLC convergences," *IEEE Photon. J.*, vol. 7, no. 4, Aug. 2015, Art. ID 7201611.
- [3] M. A. Khalighi and M. Uysal, "Survey on free space optical communication: A communication theory perspective," *IEEE Commun. Surveys Tuts.*, vol. 16, no. 4, pp. 2231–2258, 4th Quart. 2014.
- [4] K. Wang, A. Nirmalathas, C. Lin, and E. Skafidas, "High-speed optical wireless communication system for indoor applications," *IEEE Photon. Technol. Lett.*, vol. 23, no. 8, pp. 519–521, Apr. 2011.
- [5] H. Henniger and O. Wilfert, "An introduction to free-space optical communications," *Radioeng.*, vol. 19, no. 2, pp. 203–212, 2010.
- [6] J. C. Juarez *et al.*, "Free-space optical communications for next-generation military networks," *IEEE Commun. Mag.*, vol. 44, no. 11, pp. 46–51, Nov. 2006.
- [7] H. H. Lu *et al.*, "10 m/25 Gbps LiFi transmission system based on a two-stage injection-locked 680 nm VCSEL transmitter," *Opt. Lett.*, vol. 40, no. 19, pp. 4563–4566, 2015.
- [8] C. L. Ying, "20-Gbps optical LiFi transport system," *Opt. Lett.*, vol. 40, no. 14, pp. 3276–3279, Jul. 2015.

- [9] I. I. Kim, B. McArthur, and E. Korevaar, "Comparison of laser beam propagation at 785 nm and 1550 nm in fog and haze for optical wireless communications," in *Proc. SPIE 4214, Opt. Wireless Commun. III*, 2001, pp. 1–12.
- [10] M. Ijaz *et al.*, "Comparison of 830 nm and 1550 nm based free space optical communications link under controlled fog conditions," in *Proc. IEEE 8th IET Int. Symp. Commun. Syst., Netw. Digit. Signal Process.*, 2012, pp. 1–5.
- [11] C. Y. Chen *et al.*, "Full-duplex lightwave transport systems based on long-haul SMF and optical free-space transmissions," *Opt. Exp.*, vol. 21, no. 20, pp. 23655–23661, 2013.
- [12] F. Alsaadi and J. Elmirghani, "Performance evaluation of 2.5 Gbit/s and 5 Gbit/s optical wireless systems employing a two dimensional adaptive beam clustering method and imaging diversity detection," *IEEE J. Sel. Areas. Commun.*, vol. 27, no. 8, pp. 1507–1519, Oct. 2009.