

Frequency-multiplexing transmission of video and wireless signals utilizing FM conversion method

Ryo Miyatake^{1, a)}, Toshiaki Shitaba¹, Akihiro Tanabe¹, Youichi Fukada¹, Masayoshi Sekiguchi¹, and Tomoaki Yoshida¹

Abstract Video transmission over optical fiber is becoming more and more popular every year. If we can expand this technology to enable wideband signals that multiplex both video and wireless signals to be transmitted using only a single optical transmitter, various new values can be created. Therefore, we have improved our high-performance video transmitter that achieved the world's longest-distance transmission in our previous study by optimizing its FM center frequency. Our transmission experiments with multiplexed video and wireless signals demonstrate that the resultant signal can satisfy the target quality specified by the Ministerial Ordinance and 3GPP.

Keywords: analog-radio over fiber (A-RoF), broadcasting, frequency modulation conversion (FM conversion), frequency multiplexing, optical transmission, wireless signal

Classification: Transmission systems and transmission equipment for communications

1. Introduction

In Japan, the usage of video transmission by optical fiber is increasing year by year [1, 2]. In this type of transmission, videos such as community antenna television (CATV) and broadcasting satellite/communication satellite (BS/CS) are distributed from the video supplier's building to each user's home. If we can expand this video transmission service to enable wideband signals that multiplex both video and wireless signals to be transmitted using a single optical transmitter, it could generate new value both immediately and in the long-term.

First, we describe the value that can be created immediately. If it is possible to multiplex video and wireless signals and transmit them using a single transmitter and single optical fiber, it would enable cost reduction, energy efficiency, and space-saving for existing services. In recent years, several cable television suppliers providing video transmission services have launched new services for optical transmission of wireless signals such as local-5G to residences and other locations [3], as shown in Fig. 1(a). In these services provided by existing CATV suppliers, local-5G signals and video signals are typically transmitted using separate optical transmitters and optical fibers, for two reasons. First, it is difficult to construct a wideband transmitter capable

of transmitting all signals using frequency multiplexing, and second, when video signals and wireless signals are frequency-multiplexed, distortions occur within the transmitter and optical fiber, resulting in an inability to achieve the desired quality for each signal. If we could transmit these multiplexed wideband signals through a single transmitter, it would lead to space-saving installations and more energy-efficient operations compared to the conventional practice of installing separate transmitters in the supplier's building. Moreover, the commonization of components in both transmitters would contribute to cost reduction, resulting in a more affordable transmitter, and since the installation of optical fibers for wireless signal transmission would become unnecessary, further cost savings can be expected. An example of this ideal configuration is shown in Fig. 1(b).

The long-term value we can expect through the multiplexed transmission of video and wireless signals is the improvement of indoor reception quality of high-frequency cellular signals. In recent years, cellular communication has been progressing towards the practical utilization of higher frequencies to achieve high-speed and high-capacity operation, and the usage of much higher frequencies is expected in the future. However, since radio waves generally experience greater attenuation due to shielding as frequency increases, future cellular systems will have to deal with the fact that high-frequency radio waves emitted from outdoor base stations do not always reach indoors. One potential solution is a technology known as Radio over Fiber (RoF), where wireless signals are converted into optical signals while preserving their waveform shape and then are transmitted using optical fibers. After optical transmission, the RoF signal is emitted as radio waves from antennas placed in locations such as within the building. This enables the indoor usage of high-frequency radio waves at high quality without the influence of shielding by buildings. However, the practical implementation of RoF for a cellular system requires the installation of optical fibers for RoF signal transmission, incurring substantial costs. As a solution, if we could transmit the multiplexed signal of video and cellular signals through the existing RoF lines used by video distribution, there would be no need for new fiber installation. The configuration for transmitting this video and wireless signal by frequency-multiplexing is the same as in Fig. 1(b). In summary, if we could achieve this configuration and enable the frequency multiplexing of video and wireless signals and their combined transmission through a single transmitter and a single optical fiber, the result would be cost reduction and space-saving for exist-

¹ NTT Access Network Service Systems Laboratories, NTT Corporation, Yokosuka-shi 239-0847, Japan

^{a)} ryo.miyatake@ntt.com

DOI: 10.23919/comex.2023XBL0126

Received September 26, 2023

Accepted October 18, 2023

Publicized December 12, 2023

Copyedited February 1, 2024



This work is licensed under a Creative Commons Attribution Non Commercial, No Derivatives 4.0 License.

Copyright © 2024 The Institute of Electronics, Information and Communication Engineers

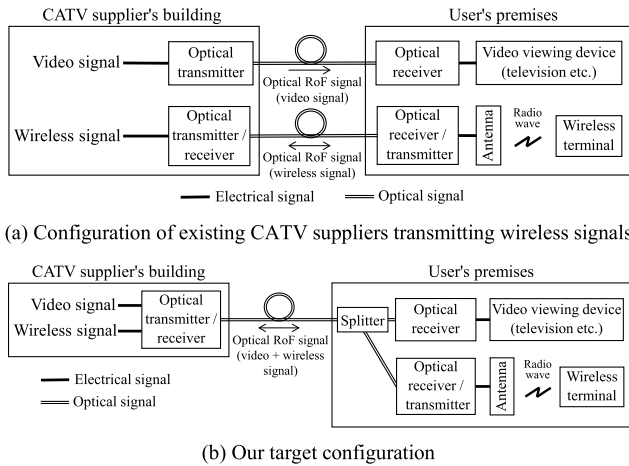

Fig. 1 Equipment and network for transmitting video and wireless signals.

ing video transmission systems in the immediate term, and enhanced indoor reception quality for high-frequency next-generation cellular services in the long-term.

In our previous work, we have conducted business deployments of a 2.1-GHz bandwidth video transmission system utilizing analog radio over fiber (A-RoF) technology [4] and investigated ways of broadening its bandwidth [5]. In [5], we expanded the total transmittable bandwidth of the system from 2.1 GHz to 3.2 GHz to transmit BS/CS (4K/8K) signals in addition to conventional signals, and confirmed that it is possible to transmit high-quality signals that satisfy the target value set by the Ministry of Internal Affairs and Communications. Although we achieved the world's longest distance for A-RoF transmission of broadband signals using this transmitter, our work thus far has been limited to the transmission of video signals only. If we could utilize our transmitter for the transmission of a wideband signal that combines both video and wireless signals, the benefits discussed earlier could be obtained.

Therefore, in this study, we utilize our transmitter to investigate the feasibility of transmitting a wideband signal (total bandwidth of 3.5 GHz) that multiplexes both video and wireless signals.

2. Conventional and proposed configurations

Figure 2 shows a prototype of the high-quality/wide-bandwidth optical transmitter from our previous study [5]. In contrast to the conventional CATV supplier's optical transmitter (Fig. 1(a)), which utilizes the intensity modulation method [6] to create the transmission signal, our transmitter (Fig. 2) uses the frequency modulation conversion (FM conversion) method [7]. Although the FM conversion method has a more complicated configuration than the intensity modulation method, it has the advantage of being highly noise-resistant, thereby ensuring high-quality transmission over long distances [8]. Taking advantage of this characteristic, we were able to successfully transmit a total bandwidth of 3.2-GHz video signals (including 4K/8K signals) over the world's longest distance in A-RoF [5]. All input signals in the configuration shown in Fig. 2 are video signals. The video signal input to the transmitter consists of CATV signals,

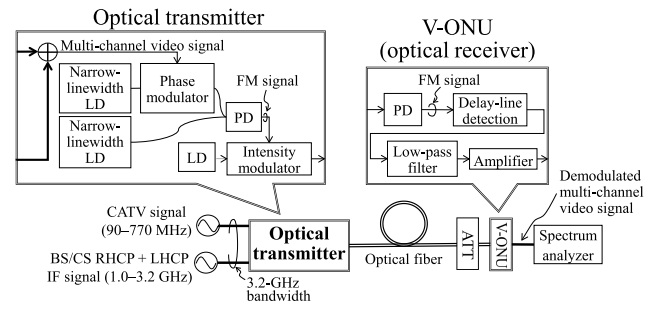

Fig. 2 Optical transmitter/receiver and transmission network in our previous study [5].

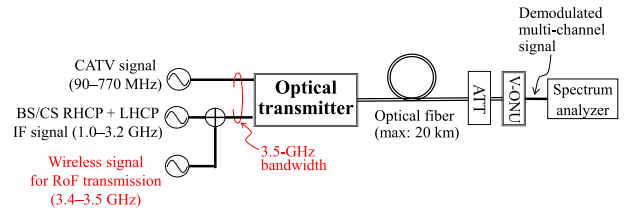

Fig. 3 Proposed configuration in this study.

BS/CS right-handed circular polarization (RHCP) intermediate frequency (IF) signals, and BS/CS left-handed circular polarization (LHCP) IF signals, in order from the low frequency side, and the total bandwidth is 3.2 GHz. Inside the transmitter, the 3.2 GHz-width signal is FM-converted by a phase modulator and photodiode (PD), intensity-modulated by an intensity-modulator, and output as an optical signal from the optical transmitter.

Figure 3 shows the configuration we propose in this paper. In this configuration, a frequency-multiplexed video and wireless signal is input to the transmitter to simulate the configuration shown in Fig. 1(b), and the total bandwidth of the input signal becomes 3.5 GHz, which is an increase from the 3.2 GHz in Fig. 2. The transmission distance is set to 20 km, which is the same distance assumed by a typical CATV supplier's transmission [9].

The wireless signal input to the transmitter in Fig. 3 is a local-5G test model signal (test model name: NR-FR1-TM1.1) specified in ETSI TS 138 141-1 of 3GPP [10] to simulate a local-5G signal. This signal has a bandwidth of 100 MHz and a modulation method of 64 quadrature amplitude modulation (64QAM). The center frequency of an actual local-5G signal is 4.5 GHz or 28 GHz, but since the maximum input bandwidth of our transmitter is limited to 3.5 GHz, we set the center frequency of the wireless signal input to the optical transmitter to 3.45 GHz. In addition, the actual local-5G signal uses not only 64QAM but also up to 256QAM, but since this is an initial study on the transmission of a multiplexed signal, we limit the modulation method of the input signal to 64QAM only. Also, the system shown in Fig. 3 is set up to simulate Fig. 1(b), but again, since this is an initial study, we do not implement the splitter, radio wave transmission to the space at the rear of the RoF section, and bidirectional communication shown in Fig. 1(b). Our main focus is the quality evaluation of the multiplexed transmission of video and wireless signals.

3. Experimental conditions

We conducted transmission experiments of frequency-multiplexed video and wireless signals using the proposed configuration in Fig. 3 and evaluated the quality of the received signals. The transmitter and receiver (video-optical network unit, V-ONU) are the same as in our previous study [5].

Figure 4 shows an overview of the input signal's frequency spectrum to the optical transmitter. The input signal is a frequency-multiplexed wideband signal consisting of a video signal (105 MHz to 3210 MHz) and a wireless signal (3400 MHz to 3500 MHz). Table I lists the number of input channels, modulation method, and target value (government standard value) of the video signals. These modulation methods and target values are defined by the Ministry of Internal Affairs and Communications. The bandwidths of the phase modulator, PD, and intensity modulator utilized in the transmitter are 4 GHz, 11 GHz, and 12 GHz, respectively. The linewidth of the narrow linewidth laser diode (LD) used in the transmitter is 15 kHz. The wavelength of the light output from the transmitter is 1558 nm. The experiments were conducted with optical signal transmission distances of 0 km, 10 km, and 20 km.

The received optical power at the receiver (V-ONU) was adjusted to -12 dBm, which is the V-ONU's minimum input value specified by ITU's recommendation [7], using an attenuator (ATT). Quality evaluation of the received signal was performed with a spectrum analyzer at the rear of the

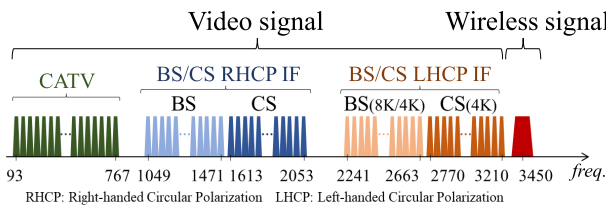

Fig. 4 Overview of frequency spectrum of the input signal.

Table I Input parameters and standard values of video signal.

	Total no. of channels	Modulation method	Government standard value (dB)
CATV (105–465 MHz)	42	256QAM	33
CATV (473–752 MHz)	36	64QAM	27
RH BS (1049–1471 MHz)	12	8PSK	14
CP CS (1613–2053 MHz)	12	QPSK	9
LH BS (2241–2663 MHz)	12	16APSK	14
CP CS (2770–3210 MHz)	12	8PSK	12

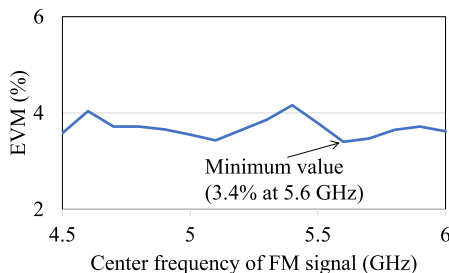

Fig. 5 Preliminary experiment to determine changes in EVM characteristics of received signals for each FM center frequency.

V-ONU (Fig. 3). Video signals were evaluated by carrier to noise ratio (CNR) with reference to the Ministerial Ordinance values specified by the Ministry of Internal Affairs and Communications [11]. Wireless signals were evaluated by error vector magnitude (EVM) with reference to the local-5G specification [10]. In addition to transmitting the signal shown in Fig. 4, where video and wireless signals are multiplexed, we performed video signal-only and wireless signal-only transmission, and evaluated their quality. Since the quality of the received signal is also considered to depend on the center frequency of the FM signal (FM center frequency) generated inside the transmitter, we conducted a preliminary experiment to optimize the FM center frequency in advance, as shown in Fig. 5. In this preliminary experiment, a multiplexed signal of video and wireless signals was input to the transmitter, and the transmitter generated the transmission signal by changing the FM center frequency from 4.5 GHz to 6 GHz. The received optical power at the V-ONU was adjusted to $+1$ dBm, which is the V-ONU's maximum input value specified by ITU's recommendation [7]. Then, we evaluated the EVM characteristics of the wireless signal in the receiver (V-ONU). The results in Fig. 5 show that the FM center frequency of 5.6 GHz had the best EVM, although the difference was slight. Therefore, we conducted the following experiments with the FM center frequency fixed to 5.6 GHz.

4. Experimental results and discussion

Figure 6 shows the raw waveforms of the received signal when the transmission experiments were conducted under the configuration and conditions described in Fig. 3 and Section 3. The transmission distance was set to 0 km. As we can see, the video signals (frequency: 0–3.2 GHz) and wireless signals (frequency: 3.4–3.5 GHz) were correctly received by the V-ONU.

Next, Figs. 7 and 8 show the received signal quality focused on the video signal band (0–3.2 GHz), and the wireless signal band (3.4–3.5 GHz) in Fig. 6, respectively. Video signals were evaluated by CNR with reference to the Ministerial Ordinance values specified by the Ministry of Internal Affairs and Communications [11]. Wireless signals were evaluated by EVM with reference to the local-5G specification [10]. CNR signifies higher quality as the value increases, and EVM signifies higher quality as the value decreases. As we can see, the video signals and wireless signals respectively satisfied the CNR and EVM target values at each transmission distance. Additionally, as shown in Fig. 7, the characteristics were degraded in the case of multiplexed transmission of video and wireless signals compared to the case where only video signals were transmitted. In general, the FM signal spectrum remains in the signal band after demodulation (called a residual FM signal), and the wider the FM signal bandwidth, the larger the amplitude of the residual FM signal spectrum. Therefore, in Fig. 7, we consider that the CNR degradation due to the residual FM signal was higher in the case of video and radio multiplexing than only video signal transmission, because the bandwidth was wider.

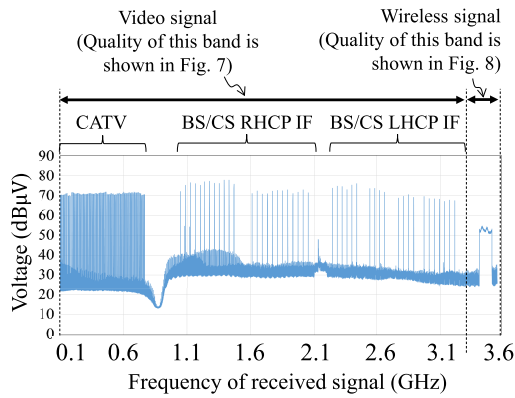

Fig. 6 Raw waveform of received signal.

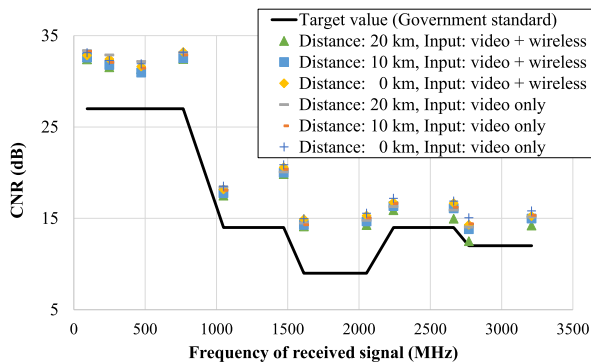

Fig. 7 Quality of received signal (video signal band).

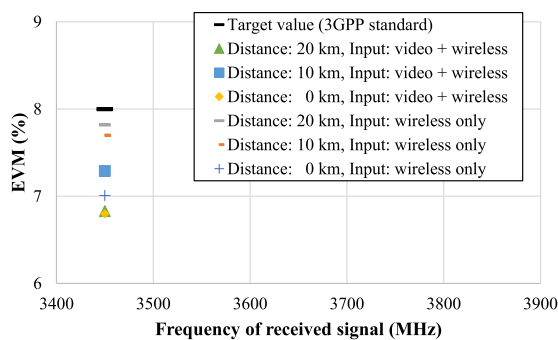

Fig. 8 Quality of received signal (wireless signal band).

5. Conclusion

We investigated the transmission of frequency-multiplexed video and wireless signals with a total bandwidth of 3.5 GHz using a single transmitter and a single optical fiber. For the video signal, a signal composed of CATV, BS/CS, and BS/CS (4K, 8K) (as specified by the Ministry of Internal Affairs and Communications) was utilized. For the wireless signal, a simulated signal based on 3GPP's specification for local-5G was utilized. The results showed that the target transmission distance of 20 km could be achieved when the FM center frequency of the transmitted signal was 5.6 GHz.

We generated the wireless signal used in this study with a bandwidth of 100 MHz and a modulation method of 64QAM by referring to 3GPP's ETSI TS 138 141-1, which is a local-5G specification. However, the center frequency of our wireless signal is 3.45 GHz and the actual value of local-5G

is 4.5 GHz or 28 GHz, so the frequency is different from the actual one. The reason for using a different frequency is that the upper limit of frequency our transmitter can handle is around 3.5 GHz. In future work, we plan to broaden the transmission bandwidth so as to perform wireless signal transmission at actual local-5G frequencies. Furthermore, in local-5G, there are specifications for signals with higher modulation levels (e.g., 256QAM) in addition to the 64QAM utilized in the present study, so we intend to evaluate the characteristics at modulation levels other than 64QAM. Finally, this study focused on one-way communication as an initial study, but we also plan to investigate the effect of bidirectional communication on quality in the future.

References

- [1] Nippon Telegraph Telephone Corp., "Annual Report 2021," NTT Corp., Chiyoda, Tokyo, Japan, Dec. 2021.
- [2] Ministry of Internal Affairs and Communications, "The current situation of cable television," https://www.soumu.go.jp/main_content/000504511.pdf, accessed Aug. 23, 2023.
- [3] Japan Cable and Telecommunications Association, "Local 5G initiatives at cable TV operators," https://www.soumu.go.jp/main_content/000862645.pdf, accessed Aug. 23, 2023.
- [4] S. Ikeda, H. Yoshinaga, and T. Sugawa, "Recent FTTH deployment focused on video services of NTT," 2006 Eur. Conf. Opt. Commun., pp. 1–4, Sept. 24, 2006. DOI: 10.1109/ecoc.2006.4800884
- [5] R. Miyatake, T. Shitaba, A. Tanabe, Y. Fukada, M. Sekiguchi, and T. Yoshida, "Full-distance A-RoF transmission experiment utilizing frequency-optimized FM conversion," *IEEE Photon. Technol. Lett.*, vol. 35, no. 3, pp. 156–159, 2023. DOI: 10.1109/lpt.2022.3227515
- [6] International Telecommunication Union, "Transmission equipment for multi-channel television signals over optical access networks by sub-carrier multiplexing (SCM)," Rec.ITU-T J.186, June 2008.
- [7] International Telecommunication Union, "Transmission equipment for transferring multi-channel television signals over optical access networks by frequency modulation conversion," Rec.ITU-T J.185, June 2012.
- [8] H. Yoshinaga and N. Shibata, "Commercially deployed coherent system for video distribution," Dig. IEEE/LEOS Summer Topical Meetings, pp. 109–110, July 2008. DOI: 10.1109/leosst.2008.4590513
- [9] Japan Cable Television Engineering Association Standard, "Optical Network Specification for FTTH Cable Television System," 2012.
- [10] "Base Station (BS) conformance testing Part 1: Conducted conformance testing," ETSI TS 138 141-1 V15.0.0, Third Generation Partnership Project (3GPP), April 2019.
- [11] Ministerial Ordinance, Ministry of Internal Affairs and Communications, "The Government Standard for the Quality of Cable Broadcasting," no. 95, June 2011.