

Short Papers

An Integrated Reusable Remote Laboratory to Complement Electronics Teaching

Nuno Sousa, Gustavo R. Alves, and
Manuel G. Gericota, *Member, IEEE*

Abstract—The great majority of the courses on science and technology areas where lab work is a fundamental part of the apprenticeship was not until recently available to be taught at distance. This reality is changing with the dissemination of remote laboratories. Supported by resources based on new information and communication technologies, it is now possible to remotely control a wide variety of real laboratories. However, most of them are designed specifically to this purpose, are inflexible and only on its functionality they resemble the real ones. In this paper, an alternative remote lab infrastructure devoted to the study of electronics is presented. Its main characteristics are, from a teacher's perspective, reusability and simplicity of use, and from a students' point of view, an exact replication of the real lab, enabling them to complement or finish at home the work started at class. The remote laboratory is integrated in the Learning Management System in use at the school, and therefore, may be combined with other web experiments and e-learning strategies, while safeguarding security access issues.

Index Terms—E-learning tools, remote laboratories, e-labs reusability, electronics teaching.

1 INTRODUCTION

DISTANCE learning education has its origins in the 19th century. In 1840, Sir Isaac Pitman, the English inventor of shorthand, had the idea of delivering correspondence courses by mail [1]. The University of London was the first university in the world to offer distance learning degrees through its External System established in 1858 [2]. Despite the success of correspondence courses, the type and number of courses on offer remained limited to a small number of areas, mainly due to the low degree of interactivity between instructor and student. In those days, the exchange of material between them was restricted to writing paper material governed by the slow pace of the postal services.

In the second half of the 20th century this prospect started to change, with the establishment in 1969 of the United Kingdom's Open University (OU), with its mixed-media approach to teaching. Despite keeping the same way to convey the material, this was now much more diversified, from carefully constructed texts to audio and video records, and complemented with conventional broadcast radio and television. Furthermore, live sessions over the telephone were organized both individually, between the student and his assigned instructor, or in group, with other students.

However, the great revolution occurred only during the 1890s with the introduction of the e-learning concept. This concept was based on the use of a new and potent vehicle of communication—the Internet—which enabled for the first time

- N. Sousa is with the Department of Electrical and Computer Engineering, Faculty of Engineering, University of Porto, Rua Dr. Roberto Frias, 4200-465 Porto, Portugal. E-mail: nsousa@fe.up.pt.
- G.R. Alves and M.G. Gericota are with the Department of Electrical Engineering, ISEP—School of Engineering, Polytechnic Institute of Porto, Rua Dr. António Bernardino de Almeida, 4200-072 Porto, Portugal. E-mail: {gca, mgg}@isep.ipp.pt.

Manuscript received 31 Mar. 2009; revised 18 June 2009; accepted 18 Nov. 2009; published online 24 Nov. 2009.

For information on obtaining reprints of this article, please send e-mail to: lt@computer.org, and reference IEEECS Log Number TLTSI-2009-03-0051. Digital Object Identifier no. 10.1109/TLT.2009.51.

a significant level of interaction between student and teacher, and among students themselves.

Despite that great leap forward, the number of options remained restricted mostly to subjects not requiring the use of labs. Therefore, the majority of science and technology courses, with the obvious exception of computer sciences, remained unattainable.

This reality is about to change with the proliferation of remotely accessible laboratories. However, due to the specificity of the access and to the need to implement the desired interactivity, these labs, particularly those dedicated to electronics teaching, require specific resources that are very different from those used in the real labs to implement the same experiment, either in terms of the hardware to build the experiment or in terms of the software to construct a dedicated access interface [3], [4]. As a result, they present numerous drawbacks in terms of the specificity, number and cost of the resources needed, long development times, reduced reusability, and low flexibility of the remote lab. While in some of the labs, a minimum common infrastructure is shared by several experiments, in others each experiment requires its own infrastructure. These aspects potentially inhibit the generalization of the use of remote labs.

The remote lab for electronics teaching presented herein, named RemotElectLab, seeks to eliminate the identified drawbacks, proposing the use of a generic hardware platform, not specifically developed to support a remote lab, and of a generic access interface as a basis for the implementation of electronic circuits that replicate, in terms of resources, facilities, and functionality, those existing in a real lab. An identical setup is required to implement each experiment, with all experiments sharing exactly the same access interface. The RemotElectLab enables students to perform the same steps in each experiment that they would perform if doing it during a normal lab class, with the exception of the initial setup. Since it replicates, in reality, exactly the real one, results collected from both are close to a perfect match.

Currently, the RemotElectLab is being used as a complement in the course of Electronic II, second year, and first semester of the Bachelor degree on Electrical & Computer Engineering. In this course students study mainly the operation and applications of the operational amplifier. However, being a generic platform, its use is being gradually extended to other courses, namely Introductory Electronics and Power Electronics.

While not substituting entirely the necessity of the traditional hands-on approach, remote labs may complement normal classes, helping to diminish lab occupation, while, at the same time, increases lab access and enables greater temporal flexibility [5]. The access was integrated in the same Learning Management System (LMS) or e-learning platform used to interact daily with the students (Moodle) [6], enabling the proposal of experiments, its execution and the submission of final reports to be done through one single portal.

In the next section, a list of remote labs devoted to electronics teaching is presented. The identification of their possibilities and limitations was the basis for the compilation of a specifications list for the RemotElectLab. A detailed explanation of the hardware and software components is then carried out. Finally, an application example is presented to illustrate the simplicity and versatility of its use, main features and potentialities.

In the last section, some conclusions are drawn, some evaluation results are presented, and other ideas to be explored in the future are introduced.

2 REMOTE LABS IN ELECTRONICS TEACHING

In recent literature, it is possible to find several examples of remote labs dedicated to electronics teaching [7], [8], [9], [10], [11], [12], each one allowing different degrees of freedom in the configuration of the experiment by the remote user. Taking into account our aims, a restricted set of them were analysed in order to compile a list of desirable specifications that served as a basis for the development of the RemotElectLab.

The "Remote Wiring and Measurement Laboratory," described in [9] includes an 8×8 configurable array, based on solid-state relays and controlled by a Web microserver. The circuit is defined by the user by means of a visual interface, a "virtual breadboard," allowing it to "physically" wire an electrical/electronics circuit in the laboratory over the Internet. Components and wires placed around the "virtual breadboard" may be dragged to accomplish the desired configuration. A set of instruments may also be connected to any nodes of the circuit. When the user completes the circuit, the software analyzes it to determine which hardware leads are connected together and to configure the relays. Some disadvantages may be identified in this solution:

1. Assuming that the circuit may have already been assembled by the students during a lab work assignment, they have to repeat it again in the remote environment before concentrating themselves in complementary tasks like: "If I change this component, how will currents in the circuit be affected?"
2. Due to the impact of the intrinsic resistance and capacitance of the solid-state relays over the measurements, students may not rely on the remote lab circuit to repeat or confirm the measurements done in the real lab.
3. The number of possible combinations in a square matrix grows exponentially with the number of components and/or equipments; therefore, medium size/medium complexity circuits may not be built.
4. The remote lab may only be controlled by a group of students at a time; however, no information about how students may book and access the lab is mentioned in the article.

Furthermore, while desirable, excess of configuration freedom may be counterproductive, as it may divert student's attention from the main focus and objectives to be achieved in a concrete lab work assignment.

The Circuit Builder of NetLab [10] is based on a combination of a "virtual breadboard" with a 16×16 matrix module, the E1465A from Agilent, based on double pole double throw (DPDT) electro-mechanical latching relays, which enables the user to remotely wire any circuit from a set of available components and instrumentation. The relay matrix switch requires supporting hardware that includes: E8408A 4-slot VXI (VME eXtensions for Instrumentation) Mainframe and the E1406A Command Module. These components form a relay matrix-switching unit capable of communicating externally with the NetLab server through the standard instrument communication bus, GPIB (General Purpose Interface Bus), while the VXI standard communication protocol is used for the internal communication within the Command Module. The structure of latching relays in the matrix allows having two separate layers. Each layer can have its own set of components connected to it, and thus, doubles the number of experiments that can be set up remotely. By using electro-mechanical relays, this approach eliminates the disadvantage pointed out in disadvantage 1. However, apart from the disadvantage pointed out in disadvantage 3, it adds the high cost of VXI modules and GPIB-based instruments.

In [11], the described solution (ISILab) is based on a modular system named ISIBoard, consisting of a motherboard with 16 slots, where an equal number of daughterboards, hosting the target

circuits, may be inserted. A total of 18 lines are available to connect the daughterboards to power supply and to instrumentation. Each daughterboard has a unique identification code, enabling its unequivocal selection. A configurable array enables each circuit to share the same instrumentation. However, the user does not have any possibility of reconfiguring the experiment. Only a limited control over a couple of instrumentation controls (wave generator and oscilloscope) is permitted. Therefore, while disadvantages 1 and 3 are avoided, it strongly limits the learning possibilities of the experiment by preventing students from exchanging components on the circuit and from comparing the results of their actions (the "If I change this component, how will currents in the circuit be affected?" question). Another strong disadvantage is the work involved to add new experiments. Anytime a teacher decides to deliver a new one, he has to describe it, design and build the daughterboard, and develop the software interface to the instrumentation and to the experiment itself. One advantage of ISILab is its concurrent access. Several students may interact pseudosimultaneously with the lab. After submitting a new set of commands, a new cycle of measurements is concurrently executed and results returned to the student. The instrumentation panels do not change if another student executes a new cycle of measurements, and thus, the existence of multiple students accessing the lab simultaneously is concealed from each one.

The remote lab described in [12] emulates a typical traditional university electronics laboratory by using a switching matrix, based on reed relays, sockets for components, and instrument connectors. A controller and the instruments are plugged into a PXI chassis PXI-1000B (PCI Extensions for Instrumentation) from National Instruments comprising a NI PXI-6508 digital I/O board, which controls the reed relays, a system controller NI PXI-8176, a multimeter NI PXI-4060, a function generator NI PXI-5401, and an oscilloscope NI PXI-5112. Besides, the remote lab includes a triple DC power supply Agilent 3136A controlled through GPIB. The virtual front panels of the instruments mimic the appearance of those available in the lab. Two types of boards, assembled in a stack-like manner, are used: one for components and one for connecting the instruments. The teacher or a member of the lab staff mounts the components to be used in the sockets. Capacity in terms of the number of online components can be increased by adding more component boards. Students define the circuit through a "virtual breadboard," where available virtual components are at their disposal, using the mouse to position each of them on the breadboard and to do the wiring. A circuit may have up to 16 nodes. A pattern recognition algorithm produces a list similar to a PSpice net list describing the circuit, while a virtual instructor checks it in order to ascertain that the desired circuit is safe. A time-sharing scheme allows simultaneous access to up to eight students. Disadvantages 1 and 3 are evident here. Another disadvantage is the high price of the whole lab.

The analyses of the virtues and drawbacks of previous approaches helped in the compilation of a specifications list to be followed in the development of a new remote lab infrastructure for electronics teaching, the RemotElectLab described herein. Apart from improving their identified benefits, it adds new features, namely the integration within an existing LMS platform, i.e., Moodle [6].

3 THE REMOTELECTLAB CONCEPT

The main RemotElectLab development goal was to build a lab that, despite being accessed remotely, replicated the functionality and performance of a traditional, real hands-on, lab. Full reusability was also mandatory, and therefore, it should have the same degree of flexibility of a normal breadboard and accept the same components. In terms of functionality, it should be possible to execute the same circuit modifications, and to carry out the same measurements required by the experiments proposed during

normal electronics classroom lab activities. Therefore, a faithful replication of a classroom lab session would be assured. The only part that would not be possible to execute remotely would be the initial setup of the circuit. As stated before, assuming that the circuit may already have been assembled by the students during a normal lab work assignment, it would not be worthwhile if they had to repeat it again in the remote environment before concentrating themselves in the assigned tasks.

As a result of the lab reviewing done, the following specifications list was compiled:

- The implementation of a circuit should not require any specific resources, apart from those usually available on the real lab.
- The remote lab should be sufficiently flexible to enable the implementation of all the circuits proposed to the students during normal electronics teaching lab classes and their remote delivery, hence, full reusability is mandatory.
- The acquisition of voltage and current measurements and the visualisation of waveforms in several nodes of the circuit should be made possible without introducing significant errors so that remotely acquired measurements closely matched those acquired during lab classes.
- The remote exchange of components and even the execution of some circuit modifications should be possible in the same way as in a real lab, where little changes to the circuit may be required to introduce modifications in the circuit characteristics and/or behavior.
- The setup time of the experiment, done by the teacher or by a technician, should be similar to that normally necessary to assemble a new circuit on a breadboard in a real lab.
- No special skills should be required for a teacher or a trained technician to replicate the experiment and make it available remotely.
- The remote interface should be generic and no modifications should be required when a new circuit is assembled in the platform.
- The remote lab should be integrated in the same LMS in use in the school so students may have an integrated training environment.
- The equipment cost of the remote lab should not significantly exceed that of a real lab.
- The remote lab should be easily replicable.

The cost of implementing a remote lab can easily surpass that of a real lab, due to the need of acquiring instrumentation that can be remotely controlled, which presupposes the use of equipments with Ethernet or GPIB (General Purpose Interface BUS) interfaces, which, in general, leads to a significant increase in their price. Furthermore, to interact with these equipments it is necessary to install specific software drivers in a computer server and to develop appropriate communication software. The minimum set of instrumentation includes a power source with multiple fixed and adjustable voltage outputs, a bench multimeter, a bench oscilloscope with, at least, two channels, and a function generator.

The option was to use an integrated solution, the NI-ELVIS (NI Educational Laboratory Virtual Instrumentation Suite), a design and prototype environment based on virtual instrumentation [13], which may simultaneously be used in a real lab and also to serve as a platform to build a remote lab solution. The idea of an online computer integrated experiment as a complement of the on-site computer integrated experiment is viewed as the most effective experimental activity, according to [14]. The platform includes a breadboard for the assemblage of the circuits, and a set of 12 integrated instruments that comprises those listed above, plus some analog and digital I/Os. A virtual interface, based on LabVIEW [15], a graphical programming language widely used in academia and industry, and distributed with the platform, enables the access, configuration, and visualization of

the whole platform instrumentation. Additionally, other functions may be defined, programmed, and executed, just like with any other programming language. Since the full control of the platform is already based on a computer server, it facilitates the task of putting it remotely accessible by Internet, with the advantage of keeping all the locally available functionalities. Furthermore, the use of virtual instrumentation offers another advantage: the possibility of providing remotely, in a computer monitor, an interface similar to that available in the classroom lab. The circuits are assembled in a common breadboard, exactly like those that exist in real labs. The same components used in the real lab, the same wires, and the same skills are all that is needed to setup a circuit in the platform.

The cost of the full platform, including the software and taking into account the characteristics of the available instrumentation, is comparable to the cost of buying all the equipment separately, as it is usually done when equipping a real classroom lab, while avoiding the substantial higher cost of buying equipment with GPIB or Ethernet interfaces.

The remote replication of the electronics teaching lab requires also the possibility of performing measurements in some of the circuit's nodes and branches, and to make changes in the circuit's configuration, without need for local human intervention. To solve this problem, switching modules with functionality similar to multiplexers/demultiplexers, were developed, based on electro-mechanical relays. They were designed to provide a flexible solution that could be used interchangeably to perform measurements, exchange components, and reconfigure the circuit. These switching modules allow the execution of voltage and waveform measurements in different nodes of the circuit and across components, and of currents in their different branches. The error introduced in the measurements is reduced to a minimum due to the low intrinsic resistance and capacitance introduced by the electro-mechanical relays. As a result, measurements done through the remote lab closely match those obtained in the classroom lab, enabling students to verify or complement the measurements they did during normal lab class activities. They also enable the application of voltages or signals to the circuit, the exchange of components or even the reconfiguration of parts of the circuit.

The control of the modules is done through the digital address and data buses available in the platform. The configuration of their functionalities is done using the same graphical programming language used to configure the remaining instrumentation.

Another advantage of this approach is its easy integration within an existing LMS platform, making possible to aggregate the potentialities provided by the LMS, like access management, information delivery, registering of results, and evaluation, to those offered by the possibility of executing remotely a lab activity using the same resources available in the real classroom lab.

With this approach all the above listed specifications are met.

4 DESIGN AND IMPLEMENTATION STAGES OF THE REMOTELECTLAB

One of the first stages of the implementation work was the design and development of the switching modules. Like in a real lab, the platform has only a single voltmeter and a single ampere meter. Thus, the switching modules would have to have the ability to provide a way of with a single instrument to measure voltages or currents in different nodes and branches of the circuit. The most logic option in this case is to use a multiplexer-like approach. The same concept would also allow the exchange of components, by enabling the selection of different branches to be connected to the circuit. However, some limitations called for an improvement on this approach: Performing differential voltage measurements and conducting current measurements in different branches of the circuit is unfeasible with a simple multiplexer-like approach. Furthermore, two main requirements should also be fulfilled:

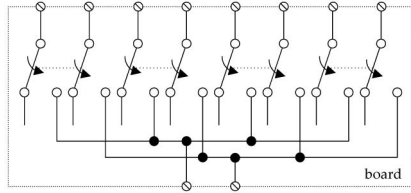

Fig. 1. DPDT-type relay in a 1-to-4 switching module configuration.

- The solution could not be limitative of the values of voltages and currents present in the real lab circuits, otherwise no compatibility would exist between the real and the remote lab implementations.
- No nonlinearities should be introduced that may interfere with its normal operation.

These requirements were eliminative of the use of transistor-based multiplexers, due to their intrinsic resistance and capacitance, and the strict limitations they impose mainly on circuit currents. The solution is to use Double Pole Double Throw (DPDT)-type electro-mechanical relays instead of any solid-state-based integrated solution. The parasitic capacitance of these electro-mechanical relays is about 2 pF with a maximum on-resistance of about 70 mΩ. The switching current is 1.25 A, around 20 times the highest current measured in the circuits currently proposed during real lab assignments. Hence, this option is the one that causes less disturbances to the circuit.

The DPDT-type relays have two independent input contacts, each one with a normally open and a normally close output. The switching modules were built with a double multiplexer design in two different configurations: 1-to-8 and two 1-to-4. Fig. 1 shows the configuration of a 1-to-4 switching multiplexer.

This double-multiplexer configuration allows the use of the switching modules to measure differential voltages while also solves the problem of measuring currents in circuit's branches. With a 1-to-8 switching module is possible to measure up to eight differential voltages or currents in an equal number of branches. Fig. 2 shows how modules are interconnected with the experimental circuit to allow those measurements.

Taking into account that component exchanges or circuit reconfigurations are generally more limited, the use of two 1-to-4 switching modules is more efficient. One single module is able to control two independent reconfiguration points in the circuit. Fig. 3 shows some examples of component exchange and circuit reconfiguration using a single two 1-to-4 switching board. The same modules may be used to acquire waveforms from up to four different points of the circuit by connecting each module's multiplexer to each one of the NI-ELVIS two channel oscilloscope.

A 4-bit address bus and an 8-bit data bus, provided by the NI-ELVIS platform, are used to select each module and send

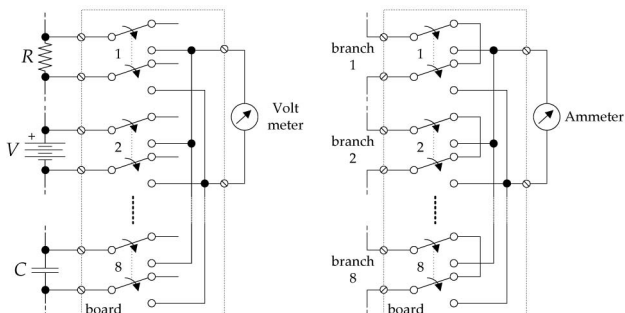

Fig. 2. Measurement of voltages and currents in different points of the circuit.

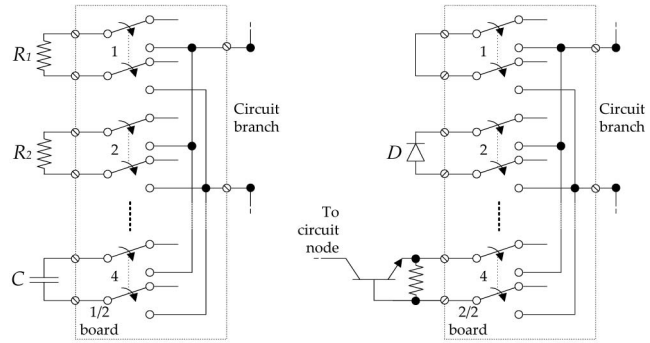

Fig. 3. Component exchange and circuit reconfiguration.

configuration data. The maximum number of switching modules that may be implemented is 12, a restriction imposed by the number of user-available addresses in the platform. A small microcontroller is responsible for receiving data and configuring the state of each relay in the module. The option for a microcontroller instead of a simple register provides more versatility to the module, allowing the local implementation of safety mechanism like assuring that during switching operations a relay never goes on before the previous went off. Each module has an address selector so they are completely interchangeable. If two modules have the same address, they will exhibit simultaneously the same behavior. The bus is implemented using a flat-cable that connects all modules. These are placed vertically, supported by an interconnection board that links the address and data buses in the NI-ELVIS breadboard to the flat-cable. Fig. 4 shows a detail of the switching module placement and a general view of the whole RemotElectLab platform.

When a new circuit is assembled in the breadboard, the teacher selects up to eight nodes and eight branches where voltages and currents will be acquired and uses the switching modules to connect them to the voltmeter and amper meter of the NI-ELVIS. He also selects the components or parts of the circuit that the student may configure during the course of the work.

The remote user interface, developed in LabVIEW, enables the student to access, configure, and visualize the results. The interface is generic and unique, completely independent from the circuit, and thus, there is no need to change or reprogram it each time the teacher or the technician replaces the assembled circuit by a new one. Fig. 5 shows the remote interface as it is seen by the student. To view it the installation of a LabVIEW plug-in is required by the client side. Occasionally, compatibility issues

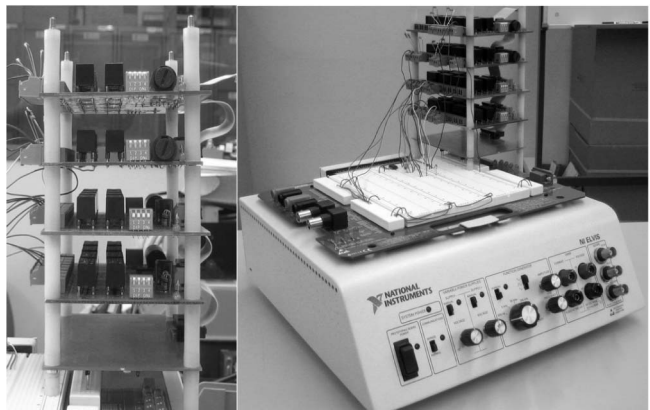

Fig. 4. Detail of the switching boards placement and global view of the RemotElectLab.

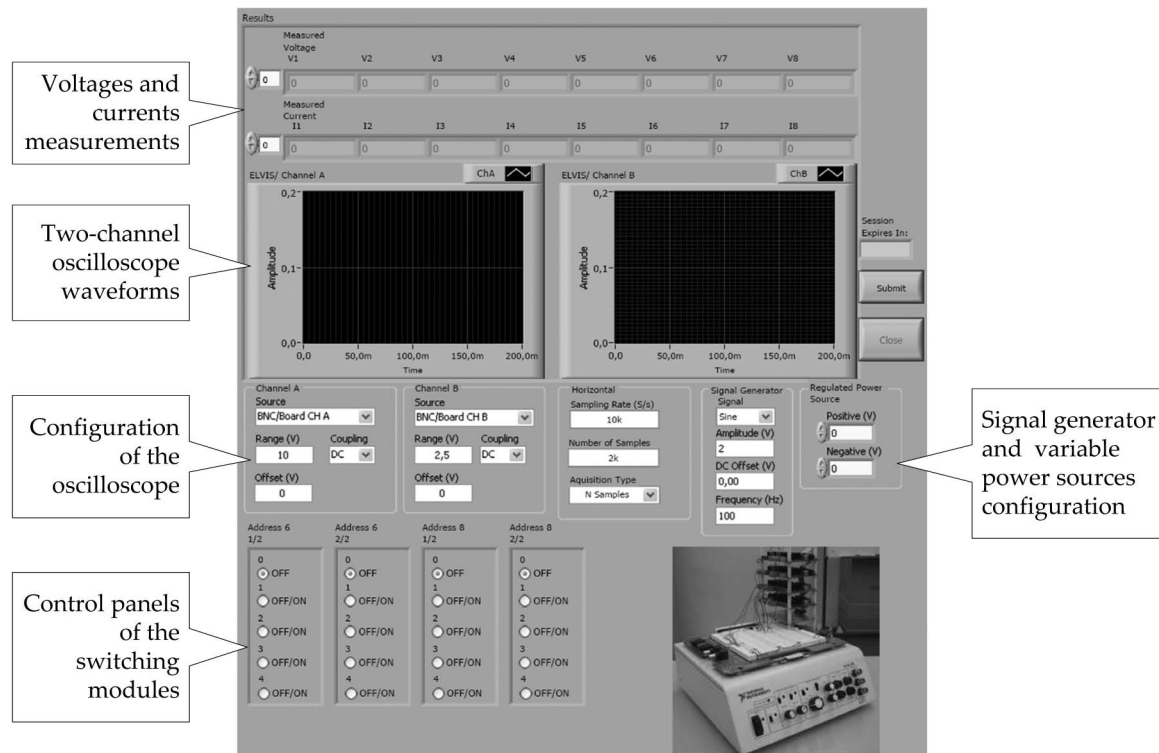

Fig. 5. Generic remote interface.

prevent the visualization of the interface. A newer version of LabVIEW no longer requires this plug-in.

An access module was developed to be integrated in the existing LMS platform, the Moodle. This module, accessible from the course's page, allows the teacher to configure the access to the experiment server, by providing its IP address and the name of the file that contains the remote user interface. It is also possible to include, if desired, a description page with text and graphics. After configuring the access module, a hyperlink is created in the Moodle course's page. Therefore, the remote lab access is fully integrated in the course page. Students access the course's page as usual, having now also the possibility of launching the remote experiment. The module generates a unique URL (Universal Resource Locator) (i.e., the link to the experience), which contains information about the student requesting the access. No simultaneous multiple accesses from the same student are allowed, preventing monopolisation or even an intentional overload that might cause the disruption of the service. The remote interface is loaded into a new Web browser page. This page is automatically closed after 30 minutes of inactivity. A descending time counter, located in the right side of the page, keeps the student aware of the time left. Meanwhile the student may configure the experiment, before submitting it. After submission, the request goes to a first-in first-out queue. A descending time counter gives the student an idea of the time he/she has to wait until getting the fresh measurement results. Each student gets his/her unique set of results. These are not affected by new cycles of configuration-submission-measurement-acquisition performed by other students using the lab concurrently. Each student's interface retains its values until receiving fresh ones from the NI-Elvis platform after a new configuration submission. In the current interface version, students cannot save the current configuration neither the results obtained, unless they use the print screen option.

Voltage and current measuring proceedings are performed automatically, under software control, each time a student submits a configuration. The switching modules scan sequentially each one of the eight voltage and current measuring points and the values are acquired by the software. After performing all

measurement acquisitions the software returns the values to the student's remote interface at once. Each configuration and measurement sequence takes about 45 seconds, which means the platform may serve around 80 configuration submissions per hour. This batch-type approach has clear advantages, in terms of occupancy rates, over the individual booking method described in [16]. When a student books an hour in the lab, the lab access is completely barred from other students, even if the student that secured the access during that hour is not effectively using it. Furthermore, while reading the results and reconfiguring it with a new configuration, the remote lab is not effectively being used, and time, and resources are being wasted.

Since the possible configurations are limited by the number of available ones, defined by the teacher, which restricts them to those aspects that the students should understand and the skills they should acquire during the execution of the experiment, avoiding dispersion, the safety of the experiment is not an issue.

The complete integration of the remote access in the LMS platform provides the student with a single integrated training environment where all the relate course material is stored. After performing all the desired configurations and analysing the results, the student uploads a report or answer a quiz about the experiment and the teacher rapidly assess the skills acquired by the student. Another advantage of this integration is the access control: Only students with granted access to the course are able to access the experiment and all accesses are registered in the LMS platform log.

5 CASE STUDY

The experiment described herein is one of those proposed to students during the study of operational amplifier applications. The circuit is a basic voltage regulator with output current limitation. The initial circuit scheme is presented in Fig. 6. During the lab work assignment students should take note of voltages and currents in several points of the circuit, while performing a defined sequence of steps:

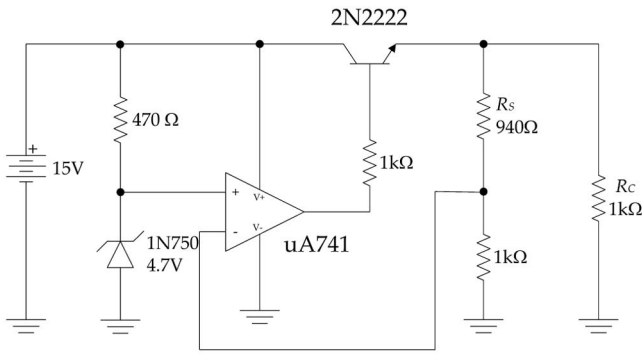

Fig. 6. Initial circuit scheme of the voltage regulator.

1. Setup the first circuit's configuration.
2. Change the load resistance (R_C) to a lower value.
3. Change the feedback resistance (R_s) to change the voltage output from 9 to 12 V.
4. Check the new circuit behavior with the previous two resistance loads.
5. Change the voltage source from 15 to 12 V and the voltage output back to 9 V.
6. Repeat steps 3, 2, and 3 again.
7. Introduce output current limitation to avoid excessive output load.
8. Repeat steps 5 and 6.

Following these steps, students are able to fully understand the implications of voltage input and load over voltage regulation, with and without output current limitation. To complete them, students need only to change two resistors, one voltage source and add a small current limiter circuit to the original configuration. All these possibilities are represented in the scheme shown in Fig. 7. Near each configuration point is indicated the address of the switching module and the number that enables the selection of the proposed options, according to the references displayed in the control panels of the switching modules on left down side of the generic remote interface shown in Fig. 5. Voltages and currents measurement signs are distributed in the circuit. The numbers indicate their references in the same generic remote interface.

From a student's point of view, the interpretation of the scheme shown in Fig. 7 is intuitive. To change the voltage source from 15 to 12 V, one should look in the remote interface (Fig. 5) for the control panel of the switching module with the address 6-1/2 and select the option 2. To set up the initial configuration, the student should choose option 1 in all switching modules. After completing the first round of measurements, he/she should change the resistor load (R_C) (change option 1 to 2 in Address 8-2/2 panel) and check the new circuit behavior. Then, he/she proceeds by changing the feedback resistance R_s (change option 1 to 2 in Address 8-1/2 panel), which will change the voltage output, and again check the

behavior of the circuit with two different resistor loads (R_C). After that, he/she should change the power source voltage from 15 to 12 V (change option 1 to 2 in Address 6-1/2 panel) and repeat previous steps, before introducing the current limiter (change option 1 to 2 in Address 6-2/2 panel).

From a teacher's perspective, passing from the initial circuit scheme shown in Fig. 6 to that on Fig. 7 is also rather easy. The teacher should track the components and configuration changes he/she wants students to perform during the experiment and introduce a switching module for each one of them. For example, instead of putting the resistor R_C in the circuit, he/she should wire the connection points to the entry of the switching module multiplexer and attach the alternative resistor options in its outputs, as shown in Fig. 3. He/she should also elect the voltages and currents to be measured during the experiment and connect the measuring points to the switching module, as shown in Fig. 2.

For the sake of simplicity, only two options were used in the circuit for each switching panel, but we may use up to four options using the two 1-to-4 switching modules, i.e., instead of having only two different resistor loads (R_C) it is possible to have up to four.

The voltage and current values measured remotely were compared with those obtained locally. The errors found were of 0.9 percent, at maximum, for voltages, and 2 percent for currents. Degradation occurred mostly due to noise interferences resulting from the use of wires to connect the various points of the circuit to the switching module and to the low accuracy of the ampere meter of the NI-ELVIS platform.

6 CONCLUSIONS

The RemotElectLab platform is a fully reusable and highly flexible remote lab for teaching electronics to undergraduate students.

The breadboard and the use of switching modules and of a generic remote interface enable the full reusability of the platform. Any of the electrical or electronic circuits usually proposed during undergraduate electronics courses may be implemented in the platform and delivered remotely. No special resources, skills, or an extended setup time is required to implement it in the platform. Since the circuit is a replication of the one assembled during real lab classes, the measures acquired remotely closely match those obtained in those classes, which enables students to finish, verify, or complement their lab work assignments at home. The module developed for the Moodle enables the integration of the remote lab in the same LMS already used by students, and therefore, pedagogical advantages may be extracted from its possible interaction with other available tools.

Students' perception toward the remote lab was evaluated through a simple final questionnaire addressing, among others, two aspects: its usability and the global satisfaction with it. Although the results indicated a positive evaluation from students, we noticed a higher score on the usability in contrast with a lower

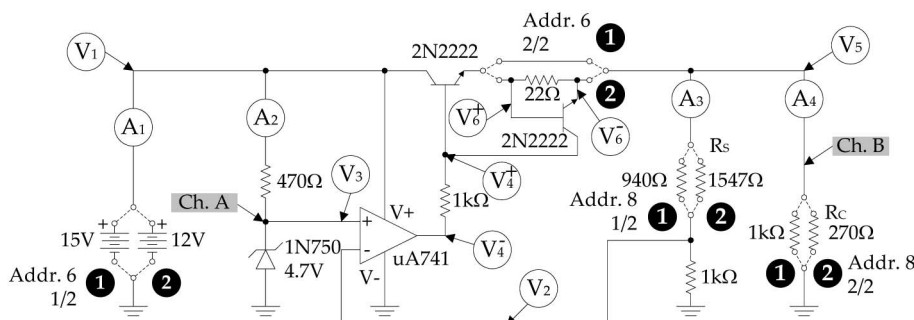

Fig. 7. Circuit scheme of the voltage regulator including the voltage, current, and waveforms acquisition points and the configuration options.

score on global satisfaction. Subsequent conversations clarified this aspect as a result of students understanding better the potential benefits of the remote lab than actually using it, which always involve communication delays and a certain feeling of distance from “the real thing.”

The flexibility provided by the switching modules while enabling the replication of the same steps performed during a lab work assignment, restricts student’s freedom avoiding dispersion from the facts he/she should understand and the skills he/she should acquire during the execution of a specific experiment.

The setup and utilization of the RemotElectLab is very simple. No special skills or a long training are required to use it, both from a student’s and from a teacher’s perspective. Furthermore, the RemotElectLab concept is simple and integrated, and therefore, is easily replicable.

Future work will concentrate on extending the available functionalities, namely adding the possibility to: save the current configuration and the outcoming results; to upload/download data for FPGA-and microprocessor-based remote experiments.

ACKNOWLEDGMENTS

The authors wish to thank to Professor Miguel Velhote Correia from the Faculty of Engineering of the University of Porto for his support.

REFERENCES

- [1] D. Matthews, “The Origins of Distance Education and Its Use in the United States,” *THE J.*, http://www.thejournal.com/articles/14278_1, Sept. 1999.
- [2] “Key Facts,” *Univ. of London External Programme Website*, http://www.londonexternal.ac.uk/about_us/facts.shtml, 2009.
- [3] C. Gravier, J. Fayolle, B. Bayard, M. Ates, and J. Lardon, “State of the Art About Remote Laboratories Paradigms—Foundations of Ongoing Mutations,” *Int’l J. Online Eng.*, vol. 4, no. 1, pp. 19-25, Feb. 2008.
- [4] E. Lindsay, P. Long, and P.K. Imbrie, “Workshop—Remote Laboratories: Approaches for the Future,” *Proc. 37th ASEE/IEEE Frontiers in Education Conf.*, pp. W1C-1-W1C-2, 2007.
- [5] J. Ma and J.V. Nickerson, “Hands-On, Simulated, and Remote Laboratories: A Comparative Literature Review,” *ACM Computing Surveys*, vol. 38, no. 3, Sept. 2006.
- [6] “Moodle Course Management System,” *Moodle Community Website*, <http://moodle.org>, 2009.
- [7] V.J. Harward et al., “The iLab Shared Architecture: A Web Services Infrastructure to Build Communities of Internet Accessible Laboratories,” *Proc. IEEE*, vol. 96, no. 6, pp. 931-950, June 2008, doi:10.1109/JPROC.2008.921607.
- [8] L.S. Indrusiak, M. Glesner, R. Reis, “On the Evolution of Remote Laboratories for Prototyping Digital Electronic Systems,” *IEEE Trans. Industrial Electronics*, vol. 54, no. 6, pp. 3069-3077, Dec. 2007, doi:10.1109/TIE.2007.907010.
- [9] J.A. Asumadu, R. Tanner, J. Fitzmaurice, M. Kelly, H. Ogunleye, J. Belter, and S.C. Koh, “A Web-Based Electrical and Electronics Remote Wiring and Measurement Laboratory (RwmLAB) Instrument,” *IEEE Trans. Instrumentation and Measurement*, vol. 54, no. 1, pp. 38-44, Feb. 2005, doi:10.1109/TIM.2004.834597.
- [10] Z. Nedic, J. Machotka, A. Sprok, L. Ruud, and S. Carr, “The Circuit Builder for NetLab,” *Proc. Eighth UICEE Ann. Conf. Eng. Education*, pp. 239-242, 2005.
- [11] A. Bagnasco, G. Parodi, and A.M. Scapolla, “A Configurable Remote Laboratory for the Flexible Setup of Experiments in Electronics,” *Advances on Remote Laboratories and e-Learning Experiences*, L. Gomes and J. Garcia-Zubía, ed., pp. 271-284, Univ. of Deusto, 2007.
- [12] I. Gustavsson, T. Olsson, H. Åkesson, J. Zackrisson, and L. Håkansson, “A Remote Electronics Laboratory for Physical Experiments Using Virtual Breadboards,” *Proc. Am. Soc. for Eng. Education Ann. Conf. & Expo.*, pp. 12235-12247, 2005.
- [13] “NI-ELVIS: Educational Design and Prototyping Platform,” *Nat’l Instruments Corp. Website*, <http://www.ni.com/nielvis>, 2009.
- [14] O.A. Soysal, “Computer Integrated Experimentation in Electrical Engineering Education over Distance,” *Proc. Am. Soc. for Eng. Education Ann. Conf. & Expo. (ASEE ’00)*, 2000.
- [15] “NI-LabVIEW Development System,” *Nat’l Instruments Corp. Website*, <http://www.ni.com/labview>, 2009.
- [16] J. Ferreira, M. Gericota, and A. Cardoso, “An Integrated Framework to Support Remote IEEE 1149.1/1149.4 Design for Test Experiments,” *Int’l J. Online Eng. (iJOE)*, vol. 2, no. 3, <http://www.i-joe.org/ojs/viewarticle.php?id=69>, Aug. 2006.