

# History of the Plasma Display Panel

Larry F. Weber, *Fellow, IEEE*

*Invited Paper*

**Abstract**—The 40 year development of the plasma display panel from the first single pixel device, invented at the University of Illinois in 1964, to the 80-in diagonal high-definition television full color products found in the department stores today is presented using photos of the many displays developed during this period. The sources of the critical ideas and inventions used in today's plasma TV products are examined in terms of the physical and electrical principles exploited.

**Index Terms**—Displays, gas discharge displays, high-definition television (HDTV), history.

## I. INTRODUCTION

PLASMA displays are enjoying an unprecedented degree of success as large-screen televisions (TVs). World sales of plasma display modules reached \$6 billion in 2005. Sales are projected to be \$8.9 billion by 2007. Plasma TV products are now available in a range of screen diagonals from 32 in to 80 in. Plasma TV worldwide unit shipments surpassed projection TV unit shipments for the first time in 2005. The start of 2005 saw the demonstration of a high quality 102 in diagonal  $1920 \times 1080$  pixel high definition plasma TV prototype. The U.S. based Consumer Electronics Association's October 2004 holiday forecast survey found that plasma TV was the most desired gift for the holiday season.

This success was preceded by a very humble beginning at the University of Illinois with the invention of the plasma display panel in 1964. The technology struggled for decades and faced many challenging problems. This paper highlights the history of the key technologies that we now find in today's plasma TVs.

Displays are exciting because they pleasantly stimulate our visual sensation. The remainder of this paper will let the display photos teach us about the fundamental principles that are used to make today's beautiful plasma TV products. They also show that it takes many years and many clever ideas for a successful technology to mature. Additional technology details can be found in [1]–[5].

## II. INVENTION OF PLASMA DISPLAY PANEL

As with any invention, it all started with a need. In this case, it was the need for a high quality display for computer-based education. The University of Illinois started a project in 1960 called PLATO (Programmed Logic for Automatic Teaching Op-

erations) to conduct research on the use of computers for education [6]. It was a pioneering project on a topic that now seems so obvious. In those days, the best computers used vacuum tubes. The first PLATO system used a TV set and a Teletype keyboard that was connected to the University's ILLIAC vacuum tube computer. The second PLATO system was a significant advance since it connected two TV sets to the ILLIAC and ran them simultaneously. This was in fact the first computer time-sharing system. It was obvious to the leaders of the PLATO project that a graphics display was a necessary component for computer education. However, in those days, even a simple alphanumeric computer terminal was a real luxury. The common method for man-machine interface was the Teletype and the punched tape.

In 1964, the "advanced technology" PLATO 3 system used the first all transistor mainframe computer (CDC 1604). The cathode-ray tube (CRT) based graphics display terminals used external scan converter memory tubes originally designed for Federal Aviation Administration (FAA) radar as the bit map storage. This was one of the few viable bit map storage technologies of that era. Of course, the semiconductor memory that we now use in our personal computers and laptops had not been developed yet. The most advanced memory of the day was core memory, but it was much too expensive to be used for graphics bit map storage.

The plasma display panel was invented by Prof. Donald L. Bitzer, Prof. H. Gene Slottow (shown in Fig. 1), and their graduate student Robert H. Wilson in 1964 to meet the need for a full graphics display for the PLATO system [7]. One of the key goals of this new graphics display invention was to have inherent memory so that the bulky and expensive scan converter tube memory could be eliminated. Fig. 2 shows an early plasma display as it was connected to the glass vacuum system used for the first plasma displays. The first device used neon gas to generate the familiar neon orange glow. Fortunately, this vacuum system had a leak that added a small amount of air to the neon. This gave the discharge a hysteresis characteristic that the inventors quickly recognized would be useful to achieve their goal of inherent memory. Pure neon gas without the leak did not have this hysteresis. The practical solution for panels that did not leak was to add a fraction of a percent of nitrogen to the neon to achieve inherent memory. The realization of the key concepts occurred in the second half of 1964 [7].

Fig. 3 shows the details of the plasma display that appear in the original patent [8]. Looking back at this invention, it had many of the key features seen in today's plasma display products. The fundamental idea was to insulate the driving electrodes

Manuscript received June 7, 2005; revised October 21, 2005.

The author, retired, was with Plasmaco, Inc., Highland, NY 12528 USA. He is now at 1 Emmy Lane, New Paltz, NY 12561 USA (e-mail: larryweber@ieee.org).

Digital Object Identifier 10.1109/TPS.2006.872440

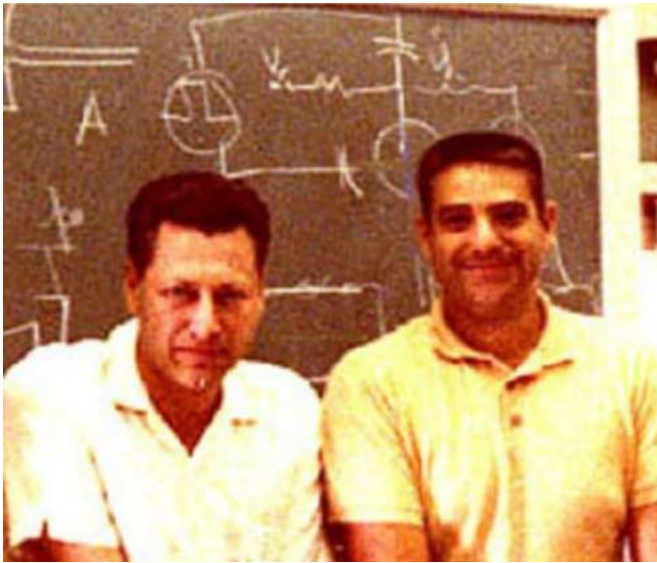

Fig. 1. Plasma display panel inventors: Prof. H. Gene Slottow (left) and Prof. Donald L. Bitzer at the University of Illinois in 1967.

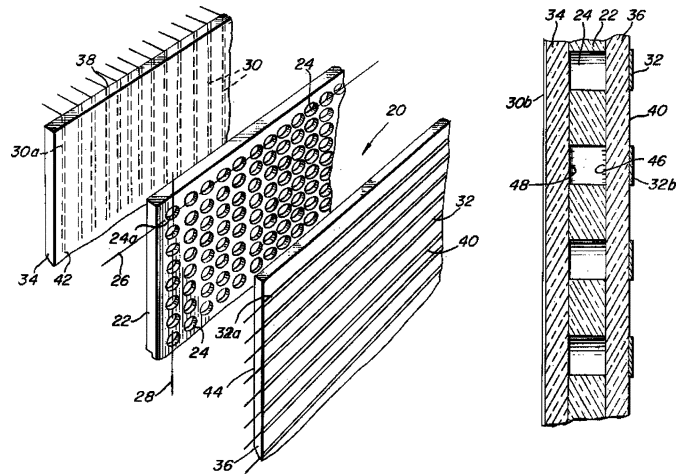

Fig. 3. Drawings from the University of Illinois plasma display panel patent [8].

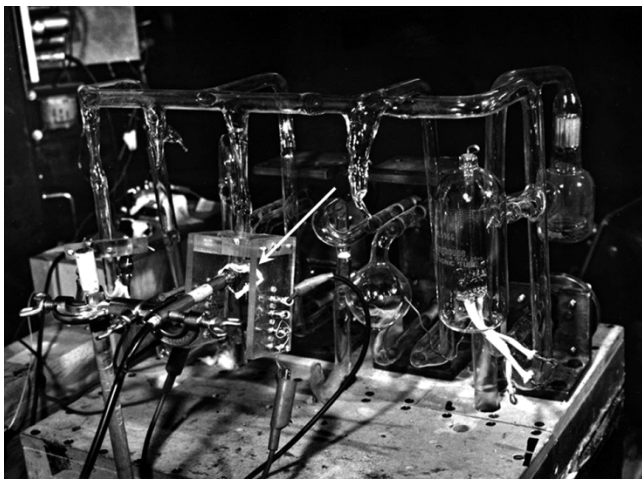

Fig. 2. Early plasma panel attached to the glass vacuum system used for the first plasma displays at the University of Illinois. Arrow points to the 1-in  $\times$  1-in panel. This had the same alternating sustain voltage, neon gas, and dielectric glass insulated electrodes that we use for plasma TVs today. Wall charge that collected on the dielectric walls allowed it to have inherent memory—just as today. Photo from [12].



Fig. 4. Early 4  $\times$  4 pixel panel presented in the first publication of the plasma display panel by University of Illinois at 1966 Fall Joint Computer Conference [10]. This panel was the first to have more than one pixel. It was also the first to achieve matrix addressability [11], [12].

with dielectric layers 34 and 36 situated between the electrodes and the neon gas mixture contained in cells 24. This served two very important functions. First, this was a very practical way to limit the current of the gas discharge and prevent arcs. The dielectric layer could be made very uniform and at low cost compared to the more common current limiting resistors. Second, the dielectric layer could be used to store charge on the walls 46 and 48, a necessary requirement for the inherent memory feature. Each pixel could store its own isolated wall charge, which allows pixels to be in either the on or the off state even when placed along a common external electrode.

The use of the dielectric layer meant that once a sufficiently high voltage was applied to the electrodes, the discharge would build up but would soon extinguish because the charge would collect on the dielectric walls. This “wall charge” would cancel the electric field induced by the voltage applied to the electrodes.

This meant that an alternating voltage was required to sustain a sequence of pulsed discharges needed to make the display bright. They called this alternating current (ac) voltage the “sustain voltage.” These results were recorded in Robert H. Wilson’s Ph.D. thesis [9].

All plasma TVs on the market today have the same features that were demonstrated in the first plasma display which was a device with only a single cell. These features include alternating sustain voltage, dielectric layer, wall charge, and a neon-based gas mixture.

Fig. 4 shows the first plasma panel with more than one pixel. This result was first published in 1966 [10]. This was a major achievement since it was also the panel that demonstrated the first matrix addressability [11], [12]. The image on the panel (“N” in this case) was selectively addressed using a write pulse applied through a resistor that biased the sustain voltage to the point where a discharge would occur. The inventors named this invention the “plasma display panel.”

Fig. 5 shows Prof. H. Gene Slottow dutifully manipulating a switch-box while he “writes” the letter “E” on the very small

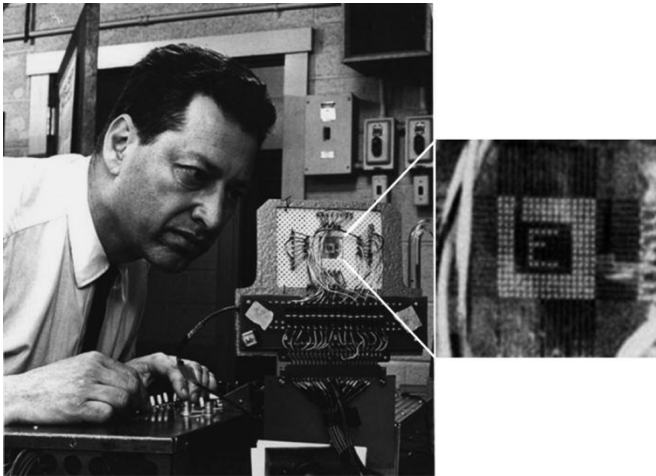

Fig. 5. Prof. H. Gene Slottow manually addressing a  $16 \times 16$  pixel plasma panel, developed by University of Illinois in 1967. Magnified view on the right shows the very small 1-in  $\times$  1-in panel with a 0.5-in  $\times$  0.5-in image. It would take many minutes to manually input the full image to the panel.

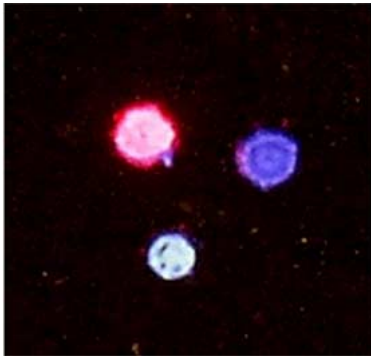

Fig. 6. First color plasma panel was this three cell prototype with red and green color phosphors excited by a xenon gas discharge [13]. It was developed at the University of Illinois in 1967. All of today's color plasma TVs generate light this way. Deep blue cell on the right had no phosphor.

plasma panel. This panel had an array of  $16 \times 16$  pixels and they could be manually addressed one at a time to display any desired pattern. This was possible because the inherent memory feature would hold the image. At this point, they had only developed a selective write method and so the procedure was to first turn all of the pixels to the off state by manually lowering the sustain voltage below the minimum sustain voltage and then raising it into the memory range. Then half selected write pulses were applied to the  $X$  and  $Y$  electrodes in order to input the desired image. It would take many minutes to manually input a full image. If a single mistake in the selective write sequence was made, the tedious process needed to be started all over because the selective erase function required to correct a mistake was not yet developed.

Another major achievement at the University of Illinois was the development of the first color plasma panel in 1967, which is shown in Fig. 6 [13]. This used the ultraviolet (UV) light generated by a xenon gas discharge to excite red and green phosphors. This device had only three cells: one with a red phosphor, one with a green phosphor, and a third with no phosphor (the one on the far right). All plasma TVs produced today use the UV light from xenon to excite the phosphors in the exact same way it was done in this early device.

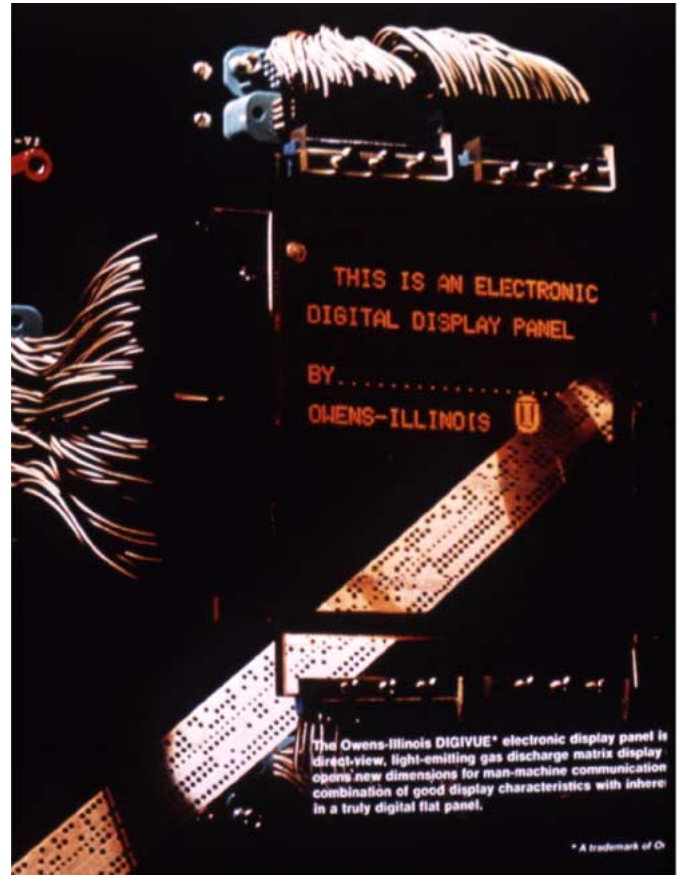

Fig. 7. Open-cell structure was used in this  $128 \times 128$  pixel plasma display developed by Owens Illinois in 1968 which measured 4 in  $\times$  4 in. This was the first practical and manufacturable structure. It used a robust 6-mm-thick glass substrate, thick film gold electrodes, and a screen printed solder glass dielectric layer. A very similar structure is used for all of today's plasma TV front plates. This display was transparent as demonstrated by the punch tape in the background.

### III. PRACTICAL COMMERCIAL STRUCTURE

The devices made by the University of Illinois proved the fundamental concepts, but they were too fragile for commercial products. They were made with three 150- $\mu\text{m}$ -thick sheets of Corning 0211 micro-sheet commonly used for microscope cover slips. The outer two sheets had very thin and fragile transparent gold electrodes placed on their outside surfaces, and the inner sheet had holes for each pixel, as shown on the right side of Fig. 3. The three sheets were bonded together with Torr-Seal vacuum epoxy, which is very visible in Fig. 4. They could not be baked to a temperature much higher than 100  $^{\circ}\text{C}$  or the epoxy would decompose. There was a constant problem of leaks, breakage, and gas contamination. The plasma display panel was doomed to failure without some significant practical advances.

Fortunately, one of the early licensees of the University plasma display technology was the large glass company Owens-Illinois. In 1968, they developed the panel shown in Fig. 7 having the open-cell structure shown in Fig. 8 [14]. This was a very practical and manufacturable structure consisting of two robust 6-mm-thick substrates made of soda-lime glass. The electrodes used thick film gold/glass paste that was screen printed and fired on each of the substrates and then coated with

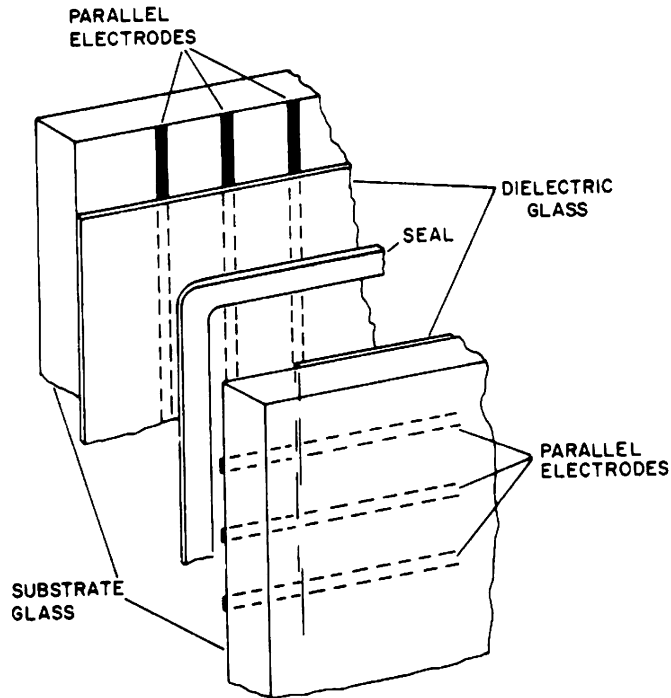

Fig. 8. Open-cell structure developed by Owens-Illinois in 1968. The substrate glass was 6 mm thick and the dielectric glass layers were 25  $\mu\text{m}$  thick. Permission for reprint, courtesy Society for Information Display.

a 25- $\mu\text{m}$ -thick-film lead-oxide-based solder-glass dielectric layer. The two plates could then be sealed together at their perimeters with a glass frit seal very similar to that used to seal CRT faceplates on to the funnel. This structure could be baked under vacuum at 350  $^{\circ}\text{C}$  to drive out contaminants and then filled with an all inert Penning gas mixture of Ne plus 0.1% Ar. This panel was strong and the gas remained pure indefinitely. These panels could be made much larger than the University devices. In 1968, they had an area of 100  $\times$  100 mm and an array of 128  $\times$  128 pixels. They were reasonably transparent and could be easily addressed for graphics, as shown in Fig. 7. The front plate of today's plasma TVs has a fundamental structure very similar to that used for the front plate of Fig. 8.

Even after this very significant breakthrough from industry, the University of Illinois continued to play an important role in the practical circuitry development by teaching to the industry the art of electronic addressing and sustaining [15]. This included designing practical transistorized circuits that found their way into many of the early plasma display products.

The plasma display received significant recognition when it won the prestigious IR-100 Award in 1968. The 16  $\times$  16 pixel panel shown in Fig. 9 is the most beautiful example of the old very fragile micro-sheet panels.

#### IV. EARLY COMMERCIAL PRODUCTS

##### A. First Product

In the next few years, a number of industrial companies continued to work toward practical products. These included Owens-Illinois, IBM, Control Data, and Fujitsu. Owens-Illinois won the race in 1971 by delivering the first practical product, which is shown in Fig. 10. This was a 512  $\times$  512 pixel-array

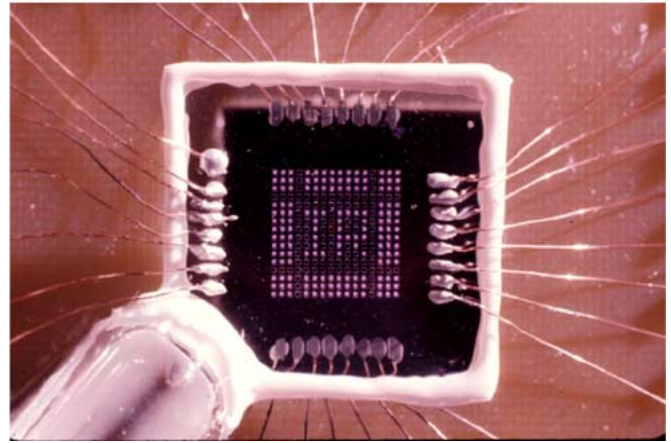

Fig. 9. 16  $\times$  16 pixel plasma display panel. The Industrial Research 100 Award was given to the University of Illinois in 1968.

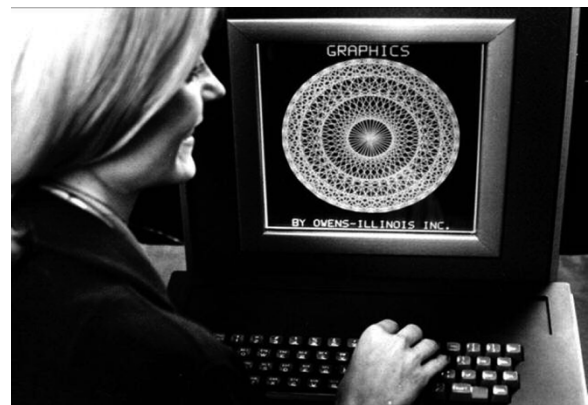

Fig. 10. Owens-Illinois delivered the first plasma display panel product to the University of Illinois in 1971. It was a 12-in diagonal, 512  $\times$  512 pixel full-graphic display with inherent memory.

full-graphic display having a square aspect ratio and a diagonal of 12 in [16]. This used the open-cell structure that Owens-Illinois had pioneered in 1968 (Figs. 7 and 8). The first customer was appropriately the University of Illinois PLATO project. Looking back, the period from the initial invention of the plasma panel in 1964 until the first product delivery in 1971 was a remarkably short time. This is reinforced by comparing Figs. 4 and 10.

##### B. MgO Cathode

The open cell structure was very practical but it was not yet optimized for display life. The lead oxide solder-glass dielectric was not a very suitable gas discharge cathode because the very energetic ions in the cathode fall would sputter the surface and change the surface structure. This would alter the ion-induced secondary electron coefficient ( $\gamma$ ) and cause the voltages to drift. Such a drift was intolerable in a display where one sustain voltage needed to be adjusted for all quarter million pixels. Unfortunately, the voltage of the pixels that were lit would drift at a different rate than the pixels that were off.

The key breakthrough came in 1971 with the development of the MgO protection layer cathode. After the dielectric glass was fired, a 500-nm-thick layer of MgO was electron-beam evaporated on both the front plate and the back plate dielectric. This refractory oxide gave very stable voltages in life tests. It had the



Fig. 11. IBM introduced a line of banking terminal products in 1973 that was the first plasma display product to use MgO as the cathode material. MgO was independently developed by IBM, Owens-Illinois, and Fujitsu in 1971. All of today's Plasma TVs use MgO cathodes.

added feature of very high ion induced secondary electron emission and so the MgO panels had a very low sustain voltage of 95 V. MgO was such a success that all of the plasma TVs sold today still use MgO cathodes.

It appears that the MgO protection layer for plasma displays was independently invented at three different companies: IBM, Owens-Illinois, and Fujitsu. The first plasma display products with MgO were introduced in October of 1973 by IBM. This was a banking terminal line of products shown in Fig. 11. Just two months later, a team from Hiroshima University and Fujitsu published the first paper mentioning use of MgO in plasma panels [17]. Arguments were made in U.S. courts for many years in order to decide which company invented MgO. Ultimately, the courts awarded the MgO patent to Owens-Illinois [18].

### C. DC Plasma Displays

The excitement of the plasma display panel stimulated interest in other ways of making displays with gas discharges. Long before the invention of the plasma display panel, a number of companies had made small numeric indicators that used light from the neon negative glow in a direct current (dc) discharge mode. These displays used a resistor to limit the discharge current instead of the capacitor used by the plasma panel. Burroughs, which had a good business making NIXIE tube numeric indicators, sent their engineers to visit Bitzer and Slottow at the University of Illinois. They returned with great enthusiasm and went on to invent the Self-Scan display [19]. This had a dc discharge that acted like a shift register and addressed the individual pixels in the panel. It had lower circuit costs due to the reduced number of external panel electrodes. Burroughs also developed a dc plasma memory method that did not require resistors [20]. This was used in many future prototype color displays.

For many years, there were two types of plasma displays. The original plasma display panel that used capacitor current limiting became known as the ac plasma display. The type that used resistor current limiting became known as the dc plasma display.



Fig. 12. Mitsubishi demonstrated this image with a true grayscale method that worked with the ac memory panel in 1972 [22]. Hitachi independently developed the same method in the same year. Before this work, true (non-spatial) grayscale was not possible for ac memory panels. We now call this method AWD. This method is now enjoying renewed research interest. Permission for reprint, courtesy Society for Information Display.

These two technologies battled each other for many years to try to become the dominant plasma display technology. Today's plasma TVs all use the ac type.

## V. EARLY TV DEVELOPMENTS

### A. Grayscale

The inherent memory of the plasma panel was wonderful for making bilevel graphic displays. However, it caused big problems for grayscale images because a pixel was either "on" or "off." It was not easy to place pixels in a half-on state. The need for grayscale in plasma panels stimulated development of error diffusion methods such as the well-known Floyd-Steinberg algorithm [21]. However, this was not sufficient for television displays.

In 1972, the grayscale problem was solved independently by Mitsubishi [22] and by Hitachi. Fig. 12 shows the first published grayscale image on an inherent memory plasma display [22]. This used the clever technique of writing and erasing every pixel many times in a given frame so that a grayscale could be observed based on the amount of time the given pixel was on during the frame. The sequence of addressing used a binary chop method to reduce the amount of addressing. We now call this the address while display (AWD) method. While today's plasma TVs do not use the AWD method, there is renewed research interest in the AWD method for enhancing performance.

### B. Barrier Ribs

Solution of the grayscale problem opened up the potential for full color plasma TV if practical color panels could be made. Owens-Illinois had successfully put phosphors in the open cell structure panels in the early 1970s [23]. Unfortunately, the color in these panels was not very well saturated. The open cell structure allowed UV light from one colored subpixel to travel to a neighboring subpixel of different color. This meant that pure colors were not possible. These panels had color but they were only pastel colors.



Fig. 13. High-quality full-color 16-in diagonal dc plasma display prototype developed by NHK in 1978 [24]. This stimulated great excitement for full-color television plasma displays.

The solution for this problem was to place barrier ribs (glass walls) between the different colored phosphors. The UV light would not go through the barrier ribs and so there was no exchange of UV light between the different colored sub-pixels. Barrier ribs allowed displays with pure saturated colors.

In the race for TV development between the ac and the dc plasma displays, the requirement for barrier ribs tipped the balance in favor of dc. Monochrome dc plasma displays needed barrier ribs in order to confine the discharge. On the other hand, monochrome ac plasma displays could use the open-cell structure of Fig. 8 that did not need barrier ribs. This is because the lateral negative charge on the dielectric glass in the regions away from the center of the pixel will confine the discharge to a small area near the center. This meant that monochrome dc plasma display products were forced to develop practical barrier rib techniques whereas the ac panels could make practical monochrome products without the complications of barrier ribs. Naturally, the dc plasma technology achieved color prototypes with good color purity long before the ac plasma type.

### C. Full-Color Plasma TV

The most active group for dc plasma color was NHK (Japanese Broadcast Corporation). Fig. 13 shows a high-quality full-color plasma TV panel with a 16 in diagonal [24]. This stimulated great excitement in 1978 that the solution of the long standing dream of “wall hanging TV” might easily be achieved in a few years. NHK continued to be a major force in the development of dc plasma color TVs. This came as a natural consequence of their pioneering development of high-definition television (HDTV). NHK realized that high resolution looked best on a large (40 or 50 in) screen because the visual acuity of the eye limits the ability to see high resolution on a small screen. The large screen potential of the plasma display could solve this problem.

While the excitement for color plasma TV was very great in the mid 1970s, it would take two more decades of development before practical color plasma TV products would emerge.

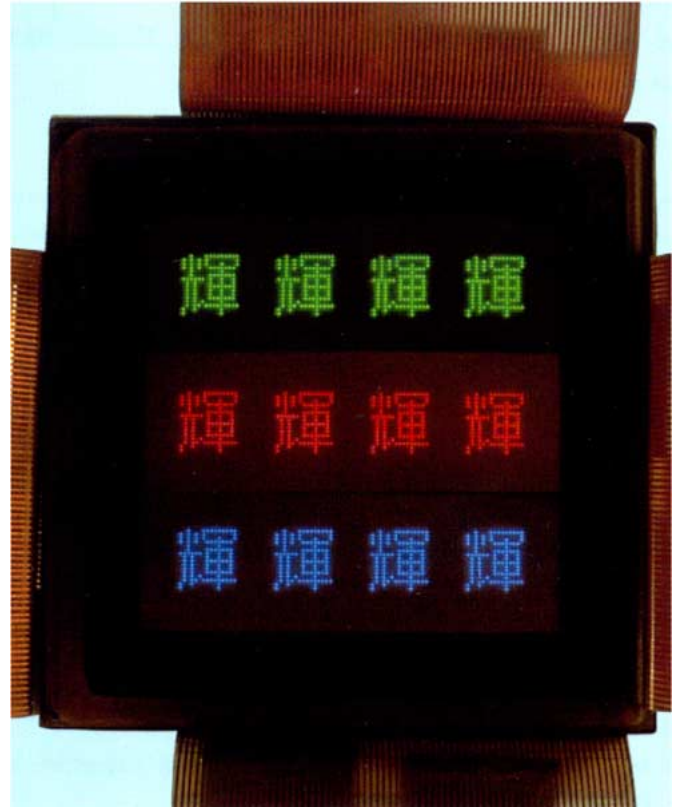

Fig. 14. Matrix surface-discharge color prototype developed by Fujitsu in 1979 [26]. This used  $X$ - $Y$  matrix electrodes on the back plate and color phosphors on the front plate. All current color plasma displays use the surface discharge.

### D. Phosphor Degradation

One major problem was the degradation of the phosphor luminance due to phosphor sputtering at the cathode. It was obviously best to place the phosphor at a location far away from the damaging energetic ions of the cathode fall. For dc plasma displays, it was easy to put the phosphors near the anode. For ac plasma displays, however, the problem was much more difficult since the anode and the cathode switched roles every half sustain cycle.

The key breakthrough for ac plasma came with the development of the surface discharge plasma display by Fujitsu. Fig. 14 shows an early prototype developed in 1979 [25], [26]. The basic idea was to place both the  $X$  and the  $Y$  orthogonal electrodes on a single glass substrate with a dielectric layer crossover placed between them to prevent shorting. The fringing fields between the two sets of orthogonal electrodes would extend into the gas and stimulate the gas discharge. The phosphors could then be placed on the second substrate, far away from the cathodes of the first substrate. All of today’s plasma TVs use the surface discharge method to separate the damaging ions from the phosphors.

### E. Luminous Efficiency

Life was not the only problem. The early color panels were not very bright and they took a lot of power. In 1984, Hitachi developed the novel panel shown in Fig. 15 [27] that achieved a record luminous efficacy of 1.5 lm/W. This was a factor of five



Fig. 15. Researchers at Hitachi achieved a record luminous efficacy of 1.5 lm/W with this dc plasma prototype in 1984 [27]. It used a new efficient discharge mode excited by very short high voltage pulses. This principle of very short pulsed discharges has also made ac plasma displays more efficient but in the ac case the discharge is short because of the action of the wall charge buildup which quenches the discharge.

times higher efficacy than the NHK panel shown in Fig. 13. The key idea here was recognition that the buildup phase of the discharge is considerably more efficient than the fully developed dc discharge. By applying very short ( $<100$  ns) repetitive high voltage pulses to the panel electrodes, the discharge would operate mostly in the transient buildup mode. This was very efficient but, unfortunately, the very short high-voltage pulses were not practical for large screen plasma displays because the electrode inductance would make the rise time too long.

The short pulse discharge mode of this dc display is very similar to the discharge of the ac plasma panel. In the ac case, the discharge grows quickly and is then quenched by the buildup of the wall voltage. AC plasma can enjoy the efficiency benefit of the short voltage pulse applied to the gas without the difficulty of externally applying short pulses. It was the luminous efficiency benefit of the ac plasma over the conventional dc plasma that allowed ac to win the race to develop practical TV products. All of the remaining plasma displays discussed in this paper are the ac type.

## VI. ADVANCED MONOCHROME PRODUCTS

During the 1970s and 1980s, the monochrome plasma display business was growing. IBM introduced the 17-in diagonal product line shown in Fig. 16 in 1983 [28]. These displays had an array of  $960 \times 768$  pixels that could present the information from four “standard” computer terminals on the large graphics screen. This product used the open-cell ac plasma display structure of Fig. 8. High quality products such as this demonstrated that plasma displays could be very practical.

During this period, there were a number of aerospace subcontractors sponsored through U.S. government research and development projects that kept the plasma display industry very active. The U.S. military had a real need for high reliability and rugged graphic displays and the plasma display was an attractive option.



Fig. 16. Monochrome  $960 \times 768$  pixel plasma display product line introduced by IBM in 1983 [28]. This 17-in diagonal display could present the information of four normal computer displays of that era.

One especially remarkable product, developed under one of these U.S. government sponsored projects is shown in Fig. 17 [29]. This was developed and manufactured in 1987 by Photonics. This 59-in diagonal monochrome display had  $2048 \times 2048$  pixels. This was produced in small quantity using the open-cell structure of Fig. 8 and was used mostly for military applications. Such a large panel had very significant electrode resistance and inductance that could cause undesirable voltage droop from the large ac discharge current pulses. It had a very large capacitance that needed to be charged and discharged frequently by the high power sustain circuit. The characteristics of each of the 4 million pixels in the panel needed tight tolerance of the discharge voltage thresholds so that one sustain voltage level could be found where all pixels would work properly. This panel clearly demonstrated that all of these difficult challenges could be successfully managed in a practical large screen product. This helped encourage future development of large-diagonal full-color plasma displays in Japan.

## VII. COLOR TV SOLUTIONS

### A. Three-Electrode Panel With Parallel Sustain Electrodes

Color plasma research and development continued to advance. Fig. 18 shows the three-electrode panel developed by Fujitsu in 1984 [30]. This was an improvement of the surface discharge design of Fig. 14, which suffered from a very large parasitic capacitance at the dielectric crossovers between the orthogonal  $X$  and  $Y$  sustain electrodes. Driving this large capacitance with high-voltage pulses would cause a great deal of power dissipation in the sustain circuit. There was one dielectric crossover for each subpixel and so there was a very significant amount of capacitance. The Fig. 18 improvement was to eliminate the dielectric crossover between the sustain



Fig. 17. The 59-in diagonal product with  $2048 \times 2048$  monochrome pixels developed by Photonics in 1987 [29]. This product clearly demonstrated that large size plasma displays were possible. This presented good proof that the issues of electrode resistance, inductance, panel capacitance, and addressability of such large panels were manageable.



Fig. 18. Three-electrode color prototype developed by Fujitsu in 1984 [30]. It had three driven electrodes and one additional floating electrode. All electrodes were placed on the back plate, and only the phosphor on the front plate.

electrodes by making them parallel instead of orthogonal. The fringing field from parallel sustain electrodes could still extend out into the gas and excite the discharge. Of course, a matrix display could not be made with only parallel electrodes, and so a third electrode was added and positioned orthogonal to the two parallel sustain electrodes. This third electrode is now called the data electrode, and it receives the address pulses used to input image information or data into the panel. All of today's plasma TVs use a three electrode subpixel having two parallel sustain electrodes and one orthogonal data electrode.

*B. Three-Electrode Panel With No Dielectric Crossovers*

Unfortunately, the design of Fig. 18 still suffered from considerable parasitic capacitance, not between the parallel sustain electrodes, but instead between the crossovers of the orthogonal data electrodes with the sustain electrodes. The key so-



Fig. 19. First three electrode product introduced by AT&T in 1986 [31], [32]. This monochrome surface-discharge panel had the data electrodes on the front plate in addition to the parallel sustain electrodes on the back plate. The barrier ribs were on the front between the data electrodes. All of today's color products use a similar three electrode structure except that the roles of the front plate and the back plates are exchanged. Property of AT&T archives. Reprinted with permission of AT&T.

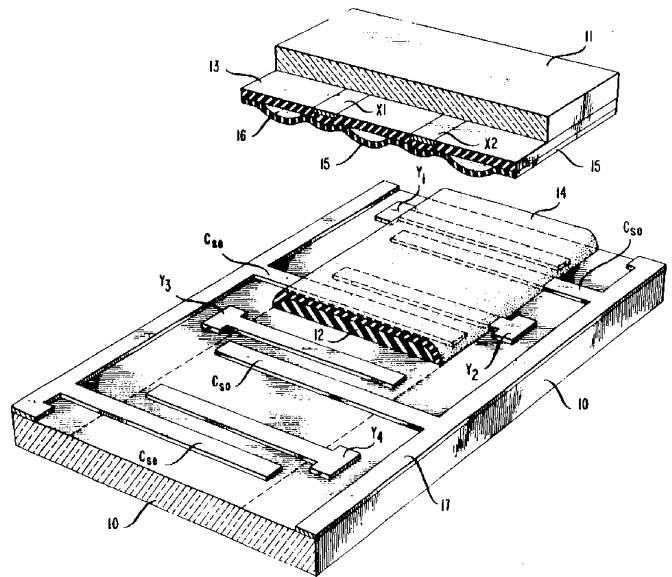

Fig. 20. AT&T three-electrode patent drawing [33].

lution to this problem was invented by AT&T Bell Laboratories [31]–[33]. The idea was developed into the monochrome product shown in Fig. 19 and introduced in 1986. The structure is shown in the patent drawing of Fig. 20 [33]. This used the same basic three electrode concept with the two parallel sustain electrodes,  $Y_n$  and  $C_s$ , along with a third orthogonal data electrode,  $X_n$ . The big difference was that the parallel sustain electrodes were placed on the rear substrate and the orthogonal data electrodes were placed on the front substrate. Placing the orthogonal data electrodes on a different substrate from the sustain electrodes eliminated the need for all dielectric crossovers and substantially reduced the panel capacitance. In addition to the new electrode arrangement, barrier ribs 16 were introduced into the front substrate so that they were orthogonal to the sustain electrodes and parallel to the data electrodes on the front substrate. These barrier ribs prevented the discharge from adversely traveling along the parallel sustain electrodes. Of course they were also very useful for preventing UV light cross talk





Fig. 21. Energy recovery sustain circuit developed at the University of Illinois in 1986 was used in this prototype [34]. This circuit is used in all of today's TV products to reduce the set power by more than 100 W.

between the different colored subpixels. All of today's plasma TVs have the data electrodes on one substrate and the parallel sustain electrodes on the other substrate.

### C. Energy Recovery Sustain Circuit

Even with the reduction in panel capacitance, the sustain circuit still dissipated a substantial amount of power for the large panels. In 1986, the University of Illinois developed a special circuit that reduced the reactive sustain power by an order of magnitude [34]. They applied it to the prototype panel shown in Fig. 21. It was called the energy recovery sustain circuit. It charged the panel capacitance through an inductance that was resonant with the panel capacitance. The  $Q$  of this inductance-capacitance ( $LC$ ) circuit could be made sufficiently high to recover 80%–90% of the energy normally lost to  $1/2 CV^2$  losses. The circuit also had low impedance switches that closed at the correct times so that the very large gas discharge current would not be sent through the relatively high impedance inductor. The energy recovery sustain circuit is used in all of today's plasma TVs to save more than 100 W in the TV set.

### D. Reflective Phosphor Panel Design

The final major step in the evolution of the color plasma display design was developed by Fujitsu in 1990 for the display shown in Fig. 22 [35], [36]. This had a significant glass panel design improvement and a significant advance in driving for grayscale. This panel design, shown in Fig. 23, placed the three color phosphors 28 on the back plate 21 which had the data electrodes 22 and the barrier ribs 29. The front plate 11 had the two parallel sustain electrodes,  $X$  and  $Y$ . This design achieved increased luminous efficiency because the phosphors were viewed in a reflective mode. The gas discharges generated by the front plate sustain electrodes and the observers were on the same side of the phosphor. This reflective mode greatly reduced the light losses compared to the previous designs such as those shown in Figs. 14, 18, and 20. These older designs placed the phosphor on the front plate where it was viewed in a less efficient transmissive mode.



Fig. 22. The 31-in prototype developed by Fujitsu in 1990. This prototype had all the elements of the modern color plasma display TV: three-electrode structure with phosphor on the back plate [35], ADS grayscale [37] and Ne–Xe gas.

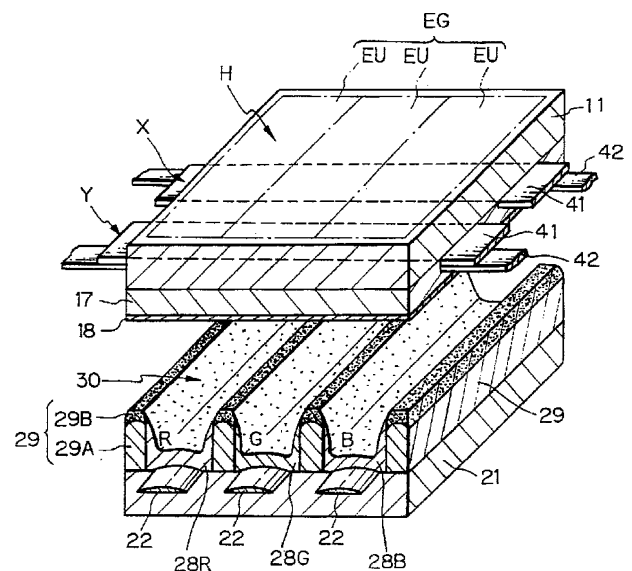

Fig. 23. Fujitsu three-electrode patent drawing [36]. This fundamental structure is used in all of today's plasma TVs.

### E. ADS Grayscale

The Fig. 22 panel was the first to have a new grayscale technique called address display separation (ADS) [37]. This method saved significant time in addressing the panel by first writing every pixel in the panel and second sustaining all of the pixels at once. Previous grayscale methods would intermix the sequence of writing and sustaining. The ADS method saved time and this time could be used to do more addressing in order to get more grayscale levels. Alternatively, the increased time could be used to supply more sustain cycles giving the panel higher luminance. The inherent memory feature of plasma displays was now of critical importance for making the TV image



Fig. 24. The 21-in diagonal prototype developed by Plasmaco in 1994, having very high dark room contrast ratio. This uses a ramp waveform to generate a Townsend discharge mode [38], [39]. This accomplished the critical priming job without significant background glow.

very bright since the brightest pixels could be discharging for a large fraction of the frame time.

All current plasma TVs use the ADS method and the phosphor is placed on the back plate so that it can be viewed in reflectance.

#### F. Ramp Waveform Priming

All gas discharges need priming particles to initiate the discharge. The plasma display discharge used to write pixels from the off state to the on state is especially dependent on good priming since the pulse that generates it is typically only one or two microseconds long. If a priming particle does not appear in a small subpixel during this short pulse, the pixel will not turn on and it will errantly appear black until the next write attempt. Some type of priming discharge is always needed in order to make writing sufficiently reliable. Unfortunately, priming discharges create light that will cause a visible background glow for the black level of the image. This can significantly reduce the dark room contrast ratio. In 1994, Plasmaco helped solve this problem with the prototype shown in Fig. 24. This used a ramp shaped voltage waveform to excite a Townsend type discharge [38], [39]. This discharge does a good job of priming without generating much light and so the dark room contrast ratios are very good. Today's plasma display TV products achieve excellent dark room contrast ratios of from 3000 to 10 000 to 1 by using the ramp waveform.

#### G. First Big Screen TV Plasma Display Product

With a solid technology base, practical color plasma TV products could be made. Fig. 25 shows the first 42-in diagonal plasma TV product introduced by Fujitsu in 1995. This used the technology shown in Fig. 23 [40]. This had an array of  $852 \times 480$  full color pixels that could display 16 million colors. Today the 42-in diagonal size accounts for 70% of all plasma TV sales.

#### H. High-Definition Plasma TVs

But plasma TVs were destined to become even larger. Fig. 26 shows the 60-in diagonal prototype demonstrated by Plasmaco



Fig. 25. First 42-in full color product introduced by Fujitsu in 1995 [40]. All of today's plasma TVs followed the lead of this product and 42 in is still the most popular size today.



Fig. 26. HDTV 60-in diagonal prototype developed by Plasmaco in 1999 [41]. This demonstrated that large screen HDTV could be very attractive. Today we have 71-in products and the largest prototype is 102 in.

in 1999 [41]. This display had  $1366 \times 768$  pixels and displayed a very high quality HDTV image. This result stimulated other companies to develop larger plasma TV products. Plasma TV products are now available in the diagonal sizes of 60, 61, 63, 65, 71, and 80 in. The pixel resolution of the 65, 71, and 80 in products is  $1920 \times 1080$ . A 102-in diagonal prototype was first demonstrated by Samsung at the beginning of 2005 and a 103-in diagonal prototype was first demonstrated by Panasonic at the beginning of 2006.

## VIII. CONCLUSION

The great success of plasma TV today can be attributed to a number of dedicated individuals and institutions that over this 40 year period solved a number of very difficult technical problems. In most cases, the companies and institutions that started the initial development work did not continue on to the final triumph of large scale commercial success. However, the technology continued to evolve and plasma TV now dominates the world market for direct view televisions larger than 40 in diagonal.

The potential for future plasma display development is enormous. The luminous efficiency of today's plasma TV products is still 50 times less than the efficiency of the common fluorescent lamp. There is still great opportunity for future dedicated engineers and scientists to play a role in the continued success of the plasma display panel.

#### ACKNOWLEDGMENT

The author is very grateful to Prof. D. L. Bitzer, Prof. B. M. Arora, and Dr. R. L. Johnson for their most helpful comments on the early history of the plasma display.

#### REFERENCES

- [1] H. G. Slottow, "Plasma displays," *IEEE Trans. Electron Devices*, vol. ED-23, no. 7, pp. 760–772, Jul. 1976.
- [2] A. Sobel, "Gas-discharge displays: The state of the art," *IEEE Trans. Electron Devices*, vol. ED-24, no. 7, pp. 835–847, Jul. 1977.
- [3] T. N. Criscimagna and P. Pleshko, *Topics in Applied Physics*. Berlin, Germany: Springer-Verlag, 1980, vol. 40, ch. 3, pp. 91–150.
- [4] L. F. Weber, "Plasma displays," in *Flat-Panel Displays and CRTs*, L. E. Tannas, Jr., Ed. New York: Van Nostrand Reinhold, 1985, ch. 10, pp. 332–414.
- [5] J. P. Boeuf, "Plasma display panels: Physics, recent developments and key issues," *J. Phys. D, Appl. Phys.*, vol. 36, no. 6, pp. R53–R79, Mar. 2003.
- [6] D. Alpert and D. L. Bitzer, "Advances in computer-based education," *Science*, vol. 167, pp. 1582–1590, Mar. 1970.
- [7] D. L. Bitzer, "Inventing the ac plasma panel," *Inf. Display*, vol. 15, pp. 22–27, Feb. 1999.
- [8] D. L. Bitzer, H. G. Slottow, and R. H. Wilson, "Gaseous display and memory apparatus," U.S. Patent 3 559 190, Jan. 26, 1971.
- [9] R. H. Wilson, "A capacitively coupled bistable gas discharge cell for computer controlled display," Univ. Illinois, Urbana-Champaign, Coordinated Sci. Lab. Rep. R-303, Jun. 1966.
- [10] D. L. Bitzer and H. G. Slottow, "The plasma display panel—a digitally addressable display with inherent memory," in *Proc. Fall Joint Comput. Conf.*, vol. 29, AFIPS Conf. Proc., Washington, DC., 1966, pp. 541–547.
- [11] B. M. Arora, D. L. Bitzer, H. G. Slottow, and R. H. Wilson, "The plasma display panel—A new device for information display and storage," in *Proc. SID Symp.*, May 1967, pp. 1–8.
- [12] B. M. Arora, "The influence of gas composition and of signal waveform on properties of the plasma display," Univ. Illinois, Urbana-Champaign, Coordinated Sci. Lab. Rep. R-377, May 1968.
- [13] E. Stredde, "The development of a multicolor plasma display panel," University of Illinois, Coordinated Sci. Lab. Rep. R-370, Nov. 1967.
- [14] J. F. Nolan, "Gas discharge display panel," in *Conf. Dig. Int. Elect. Dev. Meeting*, Washington D.C., 1969, p. 54.
- [15] R. L. Johnson, D. L. Bitzer, and H. G. Slottow, "The device characteristics of the plasma display element," *IEEE Trans. Electron Devices*, vol. ED-18, no. 9, pp. 642–649, Sep. 1971.
- [16] H. J. Hoehn and R. A. Martel, "A 60 line per in plasma display panel," *IEEE Trans. Electron Devices*, vol. ED-18, no. 9, pp. 659–663, Sep. 1971.
- [17] H. Uchiike, N. Nakayama, and M. Ohsawa, "Secondary electron emission characteristics of materials in plasma display panels," in *Proc. Int. Electron Devices Meeting*, Washington D.C., 1973, pp. 191–194.
- [18] R. E. Ernsthansen and B. W. Byrum, "Gas discharge display and memory panel with magnesium oxide coatings," U.S. Patent 3 863 089, Jan. 28, 1975.
- [19] G. E. Holz, "The primed gas discharge cell—A cost and capability improvement for gas discharge matrix displays," in *Proc. SID*, vol. 13, 1972, pp. 2–5.
- [20] G. Holz, "Pulsed gas discharged display with memory," in *Proc. SID Int. Symp.*, San Francisco, 1972, pp. 36–37.
- [21] R. Floyd and L. Steinberg, "An adaptive algorithm for spatial grey scale," in *Proc. SID Int. Symp.*, Washington D.C., 1975, pp. 36–37.
- [22] K. Kurahashi, H. Tottori, F. Isogai, and N. Tsuruta, "Plasma display with grayscale," in *Proc. SID Int. Symp.*, New York, 1973, pp. 72–73.
- [23] H. J. Hoehn and R. A. Martel, "Recent developments on three-color plasma panels," *IEEE Trans. Electron Devices*, vol. ED-20, no. 11, pp. 1078–1081, Nov. 1973.
- [24] T. Kojima, R. Toyonaga, T. Sakai, T. Tajima, S. Sega, T. Juriyama, J. Koike, and H. Murakami, "Sixteen-in gas-discharge display panel with 2-lines-at-a-time driving," in *Proc. SID*, vol. 20, 1979, pp. 153–158.
- [25] T. Shinoda, Y. Miyashita, Y. Sugimoto, and K. Yoshikawa, "Characteristics of surface-discharge color ac-plasma display panels," in *Proc. SID Int. Symp.*, New York, 1981, pp. 164–165.
- [26] T. Shinoda, K. Yoshikawa, and S. Umeda, "Characteristics of surface-discharge color ac plasma display panels," *Fujitsu Sci. Tech. J.*, vol. 19, pp. 163–176, Jun. 1983.
- [27] S. Mikoshiba and S. Shinada, "An 8-in-diagonal high-efficacy townsend-discharge memory panel color TV display," in *Proc. SID Int. Symp.*, San Francisco, CA, 1984, pp. 91–94.
- [28] P. Pleshko, G. W. Smith, D. R. Thompson, and N. Vecchiarelli, "The characteristics and performance of an experimental ac plasma 960 × 768 line panel and electronics assembly," in *Proc. Int. Electron Devices Meeting*, 1981, p. 299.
- [29] D. K. Wedding, P. S. Friedman, T. J. Soper, H. D. Holloway, and C. D. Reuter, "A 1.5-m-diagonal ac gas discharge display," in *Proc. SID Int. Symp.*, New Orleans, LA, 1987, pp. 96–99.
- [30] T. Shinoda and A. Niinuma, "Logically addressable surface discharge ac plasma display panels with a new write electrode," in *Proc. SID Int. Symp.*, San Francisco, CA, 1984, pp. 172–175.
- [31] G. W. Dick, "Three-electrode per pel ac plasma display panel," in *Proc. Int. Display Res. Conf.*, San Diego, CA, 1985, pp. 45–50.
- [32] —, "Three-electrode-per-pel ac plasma display panel," *IEEE Trans. Electron Devices*, vol. ED-33, no. 8, pp. 1169–1173, Aug. 1986.
- [33] —, "AC plasma display," U.S. Patent 4 728 864, March 1, 1988.
- [34] L. F. Weber and M. B. Wood, "Energy recovery sustain circuit for the ac plasma display," in *Proc. SID Int. Symp.*, New Orleans, LA, 1987, pp. 92–95.
- [35] T. Shinoda, M. Wakitani, T. Nanto, T. Kuria, N. Awaji, and M. Suzuki, "Improvement of luminance and luminous efficiency of surface discharge color ac PDP," in *Proc. SID Int. Symp.*, Anaheim, CA, 1991, pp. 724–731.
- [36] T. Shinoda, N. Awaji, S. Kanagu, T. Kanae, M. Wakitani, T. Nanto, and M. Miyahara, "Full color surface discharge type plasma display device," U.S. Patent 5 661 500, Aug. 26, 1997.
- [37] K. Yoshikawa, Y. Kanazawa, M. Wakitani, T. Shinoda, and O. Ohtsuka, "A full color ac plasma display with 256 grayscale," in *Japan Display Int. Display Res. Conf.*, Hiroshima, Japan, 1992, pp. 605–608.
- [38] L. F. Weber, "Plasma display device challenges," in *Asia Display '98, Int. Display Res. Conf.*, Seoul, Korea, pp. 15–27.
- [39] —, "Plasma panel exhibiting enhanced contrast," U.S. Patent 5 745 086, Apr. 28, 1998.
- [40] T. Hirose, K. Kariya, M. Wakitani, A. Otsuka, and T. Shinoda, "Performance features of a 42-in.-diagonal color plasma display," in *Proc. SID Int. Symp.*, San Diego, CA, 1996, pp. 279–282.
- [41] W. C. Schindler, "60-in diagonal plasma display," in *Proc. Int. Display Workshop*, Sendai, Japan, 1999, pp. 735–738.



**Larry F. Weber** (S'68–M'70–SM'00–F'02) received the B.S., M.S., and Ph.D. degrees in electrical engineering from the University of Illinois, Urbana-Champaign, in 1969, 1971, and 1975, respectively.

He started his career in plasma displays as a student of plasma display inventors Prof. Bitzer and Prof. Slottow. From 1969 to 1990, he conducted research on ac plasma displays at the University of Illinois Computer-based Education Research Laboratory, where he became Director of the Plasma

Display Research Group and attained the rank of Research Associate Professor. In 1987, he became a founder of Plasmaco, Inc., Highland, NY, which acquired from IBM what was then the world's largest plant for manufacturing plasma displays. He served as the Senior Vice President and Chief Technology Officer of Plasmaco, Inc., from 1987 to 1993. In 1993, he became President of Plasmaco, Inc. Under his leadership, Plasmaco, Inc., became a wholly owned subsidiary of Matsushita in 1996. He was the President and CEO of Plasmaco, Inc., from 1996 until his retirement in 2004. He has published over 40 papers and holds 15 patents on plasma displays including the patents for the energy recovery sustain circuit, and the ramp setup waveform used in color plasma display TV products.

Dr. Weber is a fellow of the Society for Information Display (SID). He has received two SID Special Recognition Awards for his work on plasma displays. SID bestowed its prestigious Karl Ferdinand Braun Prize to him in 2000, for "pioneering contributions to plasma display panel technology and its commercialization." He now serves as the President-Elect of the Society for Information Display.