

Do It Yourself Haptics: Part I

BY VINCENT HAYWARD AND KARON E. MACLEAN

This article is the first of a two-part series intended as an introduction to haptic interfaces. Together they provide a general introduction to haptic interfaces, their construction, and application design. Haptic interfaces comprise hardware and software components aiming at providing computer-controlled, programmable sensations of mechanical nature, i.e., pertaining to the sense of touch. In Part I, we describe methods that have been researched and developed to date to achieve the generation of haptic sensations, the means to construct experimental devices of modest complexity, and the software components needed to drive them. In Part II of this series, we will describe some basic concepts of haptic interaction design together with several interesting applications based on this technology.

Introduction

Our purpose is to offer newcomers to haptic interface design a roadmap to help navigate through physical principles, hardware limitations, stability issues, and human perceptual demands that stand between them and the ideal of touching and feeling a virtual environment through an electromechanical device. Primary themes are awareness of how much performance is needed, guided by both physical and perceptual principles as well as control ideas, and how different system elements may be played off one another to optimize a particular trait.

In the remainder of this article, we start by orienting the reader with an overview of the primary categories of haptic displays. We address the most common of these categories in greater detail. For the relatively simple topic of vibrotactile stimulation, we review its actuators, electronics, and software. Next, we address force-feedback, outlining the major subjects that underlie correct performance in this much more involved category. In addition to hardware components, these include

some control principles and a discussion of practical means of assuring system stability. The previous material is integrated in a simple capstone example showing how to construct and architect the control of a force-feedback knob (see “The Haptic Knob” section). We close with an example of an emerging class of haptic display, which is neither vibrotactile nor based on force-feedback and which is capable of shape display (see the “Simple Surface Display” section).

Device Overview

Many methods have been proposed to create haptic sensations artificially. Until now, roughly four dominate. They can be used separately or together in a single system. These methods comprise vibrotactile devices, force-feedback systems, surface displays, and distributed tactile displays. Of these four, we discuss vibrotactile devices and force-feedback systems to the greatest extent because they are the most researched and the most broadly applied. Implementation examples of these types of interfaces are given. We mention tactile displays only briefly.

Vibrotactile Devices

Many of us are familiar with the buzzing that we experience when we receive a call on a mobile phone when the vibration function is on. Generating these vibrotactile sensations is by far the easiest and currently the most widespread means of providing haptic feedback. It can be used for many purposes such as providing silent and invisible alerts (pagers), warnings, messages coded temporally and spatially [1] or tonotopically [2], with some of the earliest applications being found in sensory substitution (1927) [3] and avionic controls (1965) [4]. Today, the dominant application of vibrotactile devices is the haptic enhancement of games, in general [5], and game controllers, in particular (Figure 1). Emerging applications include directional cueing [6], [7], advanced mobile phones [8], or mediation of distributed floor control [9].

We later see how to make simple devices that can provide vibrotactile feedback, in which their design tradeoffs can be seen. The interpretation of vibrotactile codes into meaningful sensations can be said to appeal to perception [10].

Force-Feedback Systems

The second approach that we would like to explore in this tutorial is the force-feedback interface. Where does the term force-feedback come from? In teleoperation, it is customary to designate the ideal teleoperator system as a massless, infinitely rigid stick used as a tool to work remotely [11] (see Figure 2). In this mind experiment, since the stick has no mass, at all times ($f_e = -f_h$) an operator would feel the object being poked at distance as if the stick did not exist. The idea of force-feedback in virtual reality is to replace the real object and the imaginary stick by a system of sensors and actuators connected to a computer. If one measures the displacement, d , of the tool after first encounter with the object, as determined by *collision detection* (all words in italics are defined in “Terminology”), and if we command a motor to supply a force, f_e , then theoretically the holder of the handle should have a perceptual experience identical to that of poking a real object.

Clearly, this ideal is exceedingly hard to achieve for most surfaces and tools. For a surface of any stiffness, the response $f_e(d)$ is steep: displacements are very small and forces very high. Consider, for instance, the case of a wood surface poked by a tool terminating as a rigid sphere of radius, R , of 1 mm. The Young’s modulus, E , of wood is ~ 10 GPa (along grain). Hertz’ equation, $f_e = (3/4)\sqrt{RE}d^{3/2}$ [12], indicates that for a poking force of 2.5 N, the surface deflection d is only of 5 μm . At this depth, the stiffness of the contact is nearly $10^6 \text{ N} \cdot \text{m}^{-1}$!

Authors attempting to quantify the minimal stiffness required to experience the sensation of hardness have proposed a figure of $10^4 \text{ N} \cdot \text{m}^{-1}$ [11], [13]. This stiffness, two orders of magnitude lower than that found previously, still entails severe equipment requirements. It is known, however, that humans do not rely on stiffness alone to judge and experience objects. Other cues include the ability to resist ample forces [14], high acceleration transients [15], structural response [16], accentuation of rate of change of force [17], and shock [18]. It is these, sometimes together with involuntarily generated parasitic sounds [19], but preferably with specifically designed audio or visual cues [20], [21], that are responsible for the ability of force-feedback devices to convey the feeling of relatively stiff surfaces.

Another important type of interaction is dragging the tool on the surface of the virtual object, with simulated texture, friction, stickiness, and other surface properties. Here, the numbers are no less humbling. The most banal surface interaction cases can vastly exceed the capabilities of currently available devices [22], [23]. At the most basic level, designers of force-feedback interfaces must rely on perceptual processes to produce realistic sensations.

Surface Displays

A third category of electromechanical devices that can create artificially produced haptic sensations is the surface display [24].

These devices rely on the observation that the sensation of touching an arbitrary surface can be achieved by moving a real surface under computer control while sensing the interacting finger’s position. Recent variants of this idea are known as location displays [25]–[27] or encounter-type displays [28]; see Figure 3 for an example.



Figure 1. Saitek P2600 Rumble game pad.

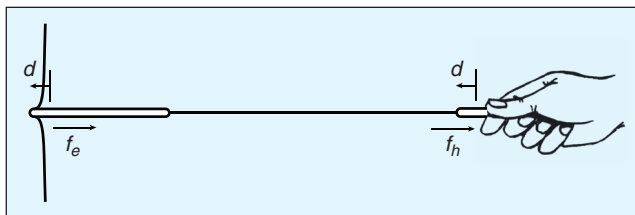

Figure 2. The idealized teleoperator. A tool having a given geometry in contact with an object is operated at a distance via the imaginary construct of a massless, infinitely rigid stick. This would be equivalent to holding the tool directly.

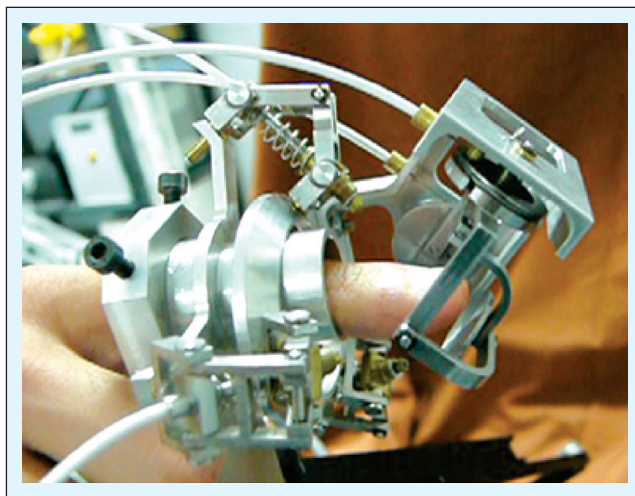

Figure 3. Location display that operates by rolling a servo-controlled plate on the fingertip as a function of the exploratory movements of the finger [27].

Terminology

Collision Detection: A computational process employed to determine whether objects represented by their geometry in a computer interfere with each other. This calculation is fundamental to many applications of virtual reality, computer-aided design, and haptics.

Back-EMF: By Lorentz Force law, a dc motor gives a torque $\tau = k_t i$ given a current i . The same law requires that when the motor turns at angular velocity, ω , a voltage $e = k_e \omega$ is generated. This EMF opposes the voltage applied to the motor (back-EMF). When connected to a voltage source (a short is a zero-voltage source), if R is the winding resistance, a current $i = e/R = k_e \omega/R$ is induced. Thus, a viscous-like torque proportional to velocity, $(k_e k_t/R)\omega$, impedes rotation. This is equivalent to viscosity and explains the first-order response. While this is fundamental to the design of servo-mechanisms in general, in haptics, it has several implications. Voltage determines the speed of a free-spinning motor. When a motor is used to generate torque from a voltage, it does so only at low velocity since the back-EMF is like viscosity. See further discussion in "Actuators" and "Amplifiers" sections.

Impedance and Admittance, and Flow and Effort: In optical, hydraulic, acoustic, mechanic, and electrical systems, there is the notion of effort and flow variables. Flow variables are connected to the position and movement of particles, for instance, mechanical position and velocity, or electrical charges and current. Effort variables are connected to the effect of a system of particles on another, for instance, mechanical force or electrical potential. There are formal and physical analogies (nonunique) between all these domains. One of them is the notion of impedance: the ratio of a variable of effort over a variable of flow. For instance, resistance is defined as voltage divided by current, or mass as force over acceleration. Conversely, an admittance is the ratio of a variable of flow over a variable of effort.

Dynamic Range: A general notion is to express the set of possible values, from the smallest to the largest, within which a quantity can be reliably determined. It is often expressed as a ratio in dB [several possible conventions, here $10 \log_{10}(\max/\min)$]. For instance, for the motor in Table 1, from the peak torque to the smallest torque determined by friction gives a ratio of roughly 100 or 20 dB of torque dynamic range. As points of comparison, an LCD display gives about 30 dB of brightness range and high-end audio systems more than 50 dB of acoustic pressure range.

Transducer: A device to convert energy from one form to another. It might function as either a sensor or an actuator and occasionally as both. An ideal transducer does this without losses or nonlinearities over an infinite frequency range. Thus, an ideal actuator used as a force transducer for haptics would convert current to torque with uniform gain regardless of frequency. As a sensor, an ideal transducer does not disturb the process being measured, has low noise, and is generally desired to be linear.

Structural Dynamics: Beyond a certain frequency, most mechanical systems do not move like a set of rigid parts. Inertial forces cause the parts to flex and bend, resulting in a variety of linear and nonlinear effects. So is the case of haptic force feedback devices. For instance, just below a resonant frequency, a motor movement may be causing the handle

to move in one direction, yet at frequency a few Hz higher, the same motor movement may cause the handle to move in the opposite direction. The analysis and control of these dynamics can be extremely complicated, which is why the lowest frequency, called the first natural frequency, at which structural dynamics appear (first mode) is an important characteristic.

Degrees of Freedom: In mechanics: the number of independent variables needed to specify the position of a system of particles. A rigid body free to move in space has six (three translational and three rotational) variables, whereas a simple knob anchored in space has only one variable, its rotation. Joints introduce constraints and leave freedoms. The most common joint, the hinge, introduces five constraints and leaves one angular freedom.

Serial Versus Parallel Linkages: Mechanisms are made of links connected by joints. See example later. If a sequence of links and joints forms at least one closed loop, the mechanism is said to parallel, otherwise it is serial.

Five-Bar Linkage: A type of mechanism with five links and five joints that has two DoF. A system of five links connected by five joints to form a loop retains two DoF under two special circumstances: when the joints axes are parallel or they meet at a single point. Parallel axes joints permit planar motions and meeting axes permit angular motions.

Capstan Drive: If a string, a rope, a tape, or a cable is wound around a cylinder—a capstan—then to a good approximation, the ratio of the tensions of the taut sections is an exponential function of the winding angle [158]. The driven load is the difference between the two tensions. It can be much higher than the tension at rest. Capstan drives are backlash-free and can operate successfully even with modest manufacturing and assembly tolerances. Master arms and haptic devices frequently use this technique to amplify torque.

Direct Drive: The motor is connected directly to the load without a torque amplifying mechanism. Advantages are simplicity and lack of the backlash or friction present in most transmissions.

Quadrature Incremental Encoder: A frequently used type position sensor that directly quantizes displacement, most often optically. The sign of one increment of displacement is coded by using two signals in phase quadrature. A displacement measurement is simply done by counting the increments. Inexpensive models give a few tens or hundreds of increments per turn. Sophisticated models can give 10^5 or 10^6 increments per turn.

Hall Effect Position Sensor: Sometimes, better results or cost/performance ratios can be obtained for haptic devices by using analog position sensors giving a signal, i.e., digitized electronically. Position sensors relying on the Hall effect where a voltage varies as a function of the intensity of a magnetic field is the most often used analog position sensor. They can be made of elementary components and very accurate ready-made sensors can be procured. Typically, the range of displacement must be smaller than a turn.

Motor Torque Ripple: A dc motor gives a torque proportional to the current. The proportionality factor can noticeably depend on the angle of the rotor in a cyclical manner. This dependency is related to poles and windings. It can also arise

when the brushes commute different windings. This can taint the haptic feel at high torques.

Motor Cogging: Certain dc motors exhibit spontaneous cyclical variations of torque as they turn, owing to changes of reluctance in the magnetic circuit. This can taint the haptic feel at low torques.

Hysteresis: If a system with inputs, outputs, and states is such that its outputs depend not only on inputs and states but also on its time history, then it is said to have hysteresis. It can be detected by slowly driving a system once through a closed trajectory and noticing that the outputs do not return to their initial state. Several components of a haptic interface can exhibit this kind of nonlinearity.

Power Amplifier: Voltage Versus Current: Electronic device able to step up the power of a control signal. Voltage amplifiers regulate voltage internally and therefore have a low internal impedance and saturate, typically, when the current is too high to maintain a demanded voltage. Conversely, current amplifiers regulate current, have a high internal impedance, and saturate when the voltage becomes too high to deliver a required current. In these cases, the circuit can be analog (also said linear) or switching (also said digital). In the switching types, power modulation is achieved by driving the signal full range at high frequency from one polarity to the other and by varying the duty cycle, i.e., the proportion of time spent in one state versus the other.

Limit Cycle: When a system exhibits a self-sustained oscillation that persists even if it is perturbed and when the amplitude of the oscillation remains bounded, this system is said to enter a limit cycle. For a limit cycle to exist, the system must have nonlinearities, the most common of which is saturation. In haptics, artifacts tainting a simulation often can be explained by the onset of limit cycles.

Passivity: In control, a system is said to be passive if at all times the energy supplied is always greater than or equal to the energy stored in it, i.e., the energy is not supplied from within the system. A simulated haptic virtual environment is said to be passive if the energy supplied to the hand does not exceed the energy supplied by it. This is a desirable quality because the interaction of the human hand with a passive object (real or simulated) is in general nonoscillatory. While the human can and does act as a power source, our biomechanics and motor control are such that a hand appears to be passive in the high frequencies (i.e., above 10 Hz roughly). An interesting exception is the drum roll that can be described as an interaction of the hand with a passive object, yet it enters a fast limit cycle.

Zero-Order Hold: The most common method to perform analog signal reconstruction from discrete samples. The analog output is held constant from one sample to the next, resulting in a staircase-shaped signal containing a (theoretically) infinite number of high frequencies.

Tactile Displays

The objective of tactile displays is to provide spatially distributed sensations directly at the skin's surface, usually on the highly sensitive fingertip. In some cases, these are targeted at replicating sensations experienced when touching real surfaces, e.g., Braille text or approximations thereof. In others, the approach is to produce sensations that do not arise naturally at all (e.g., the Optacon device [29]). Doing justice to tactile display technologies would require a separate article. The reader is referred to [30], which surveys no less than 30 different approaches to creating such distributed tactile sensations. For the purpose of this article, the authors find it impossible to suggest electromechanical devices that can be easily commissioned given limited resources. In the present state of development, while certain distributed tactile display technologies show considerable promise [31], it is fair to say that none can yet provide realistic sensations and, in the best cases, only certain aspects of these sensations.

The Art of Nonrealistic Usefulness and Realism Through Shortcuts

Fortunately, the history of displays shows that usefulness and the ability to produce realistic sensations are distinct notions. For instance, LCD color displays, even the most advanced, are far from being capable of producing optic fields that approach those produced by natural scenes, say, in terms of colors, dynamics, or visual span. However, it is an everyday experience that visual displays are quite useable even at very low quality levels, such as when watching a vintage black-and-white movie with an 8-mm film projector, as long as the content is there and

the relevant information is available at the right moment and at the right place. It is nevertheless informative to know the characteristics of the natural ambient physics to develop a sense of what remains to be technically accomplished for the most demanding applications.

Vibrotactile Stimulation

The Rumble Motor

The rumble motor operates on the same principle used in soil compacting equipment and other vibrating machinery: a motor spins an eccentric mass (Figure 4). It is just smaller. These rumble motors can be made from parts or procured ready-made from a variety of sources such as part surpluses. The sensations created by this type of device are governed by its dynamics.

A simple off-on voltage signal applied to the motor at rest from a low-impedance voltage source drives the angular velocity in a first-order step response with a time constant equal to the spinning parts' moment of inertia, divided by a damping coefficient resulting from friction and the motor's back electromotive force (*back-EMF*). With different driving voltage amplitudes, different plateau velocities are reached. So long as the motor's mount structure is free to vibrate (for instance, when loosely gripped) because of conservation of momentum, the vibration's displacement amplitude remains roughly constant regardless of speed. Meanwhile, the acceleration amplitude of the vibration grows quadratically with the angular velocity, i.e., the vibratory frequency. This invariant dynamic signature is what gives the rumble motor its distinctive feel;

not only are vibratory frequency and acceleration amplitude linked but frequency nominally grows and decays like the response of a first-order system.

While it is not possible to change the dynamics that govern the frequency-amplitude correlation of a rumble motor, it is possible, in open loop, to modify the time course of the response. This can be done by changing the electrical characteristics of the power source. A minimalist approach is to switch the motor to either a voltage or a current source. This has the effect of enabling or disabling, respectively, the damping term due to the motor's back-EMF. On the spin-up part of the response, with a current source, the speed of the motor (and the frequency of the vibration) rises quickly until saturation. With a voltage source, the speed adopts a first-order step response profile. Similarly, when power is switched off, the motor terminals can be left either open or short-circuited, yielding different effects on the spin-down portion of the response. If the terminals are left open, the spin-down is gradual but if the motor is short-circuited, it slows down in an exponential fashion.

The other possibility is to shape the input. The simplest instance of this technique is to drive the motor to spin-up for a short instant and to reverse-drive it for the same duration. If this duration is tuned to give the motor about a turn or less, the tactile result is no longer that of a vibration but rather of a thump for large motors and a click for small ones. More generally, if the dynamics of the system are identified, then it is possible, within limits, to give the system any response we desire by shaping a given input using the knowledge of the motor's inverse dynamics. It is also possible to use variable structure control strategies by switching the power at high rates. Of course, all these possibilities can be combined to give the humble rumble motor many more possibilities than meet the eye.

The Tactor

Since the early systematic studies on vibrotactile stimulation for sensory substitution of the 1920s [32] as well as more recent ones [33], [34], a standardized method to deliver a vibrotactile stimulus is to drive a small surface of a few millimeter square area, with a voice coil motor and a tactor, and place it in contact with the skin. Tactors are available from commercial sources

(e.g., Engineering Acoustics, Winter Park, Florida; Audiological Engineering, Somerville, Massachusetts). Commercial tactor drivers are sometimes designed to resonate at around 250 Hz, a frequency believed to provide maximum stimulation, in the form of short bursts of signal to counteract sensory adaptation. Tactor drivers can also be made from scavenged audio speaker drivers by providing adequate guidance to the moving coil. The approach followed in [35], for example, is simple enough to provide the basis for many homebrew designs.

Because tactors can stimulate the skin within relatively confined areas, a certain degree of spatial coding on the skin can be afforded by using a collection of tactors. This has been taken advantage of for lining clothing with a collection of tactors for artistic purposes [36], orienting astronauts in space [37], directing the attention of a user [6], and many other purposes.

The Inertial Motor

The inertial motor combines the ability of the rumble motor to efficiently vibrate a hand-held object with the voice coil-actuated tactor's ability to generate arbitrary vibration waveforms. It is made of an inertial slug (like the rumble motor) but powered by an electromagnetic arrangement or a piezoelectric element. Vibrations are also induced by conservation of momentum. If the slug accelerates in one direction, the part to which the motor is attached accelerates in the other, at a rate proportional to the current driven in the coil. If the slug is sufficiently heavy, the acceleration response is flat over a wide frequency range, allowing the frequency and the acceleration amplitude, unlike with the rumble motor, to be independently specified. The response is bounded under by the natural frequency of the suspension. While designs based on scavenged loudspeaker parts can be effective [38], this kind of motor can also be manufactured from raw materials and supplies. An efficient structure can be seen in Figure 5 [39]. Recently, vibrotactile devices have captured the imagination of human-computer interaction designers, particularly for hand-held devices. Because a hand-held device is not firmly mechanically grounded, inertial forces can be exploited to cause the screen or the case to vibrate in response to the user's input, using either electromagnetic or piezoelectric motors [40]–[43].

Electronics and Software

Vibrotactile sensations may be viewed as haptic sensations but without the dc component [44], i.e., only oscillations and transients need to be transduced. As such, the electronics and software are not different from that for audio, particularly for those devices that use voice coils. Any electronics and software designed for audio can be used for haptics with the

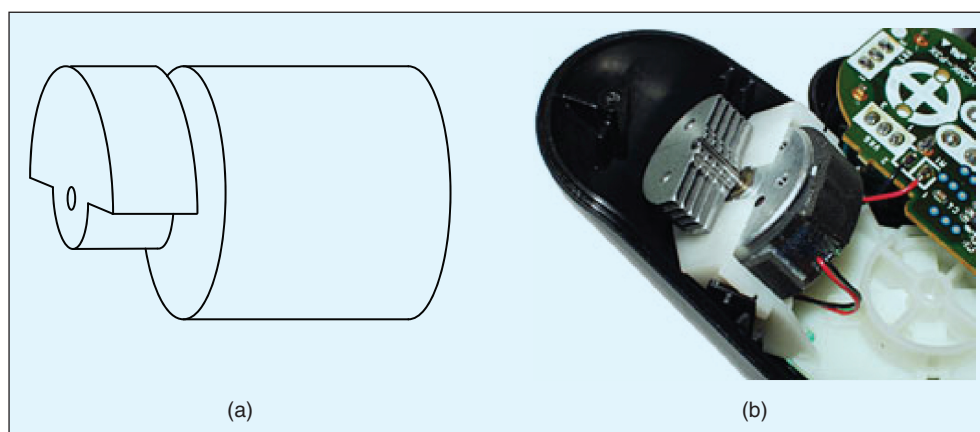

Figure 4. (a) The rumble motor. (b) An eccentric mass spun by a dc motor.

difference that the useful frequency range is limited to about 1,000 Hz.

Interestingly, sound synthesis software, extensively researched for many decades, can be readily used for tactile vibrations. Ready-made real-time audio synthesis software that can modify the output waveform as a function of external signals, e.g., other vibrations (sound) and/or displacement signals (mice, trackers), is particularly appropriate [45]. More generally, the full gamut of audio synthesis techniques [46] is available for haptics [47]–[50], including sampling and reproduction [44], [51]. For tactile messages, basic software could allow the setting of parameters familiar in audio signal design, such as frequency, waveform, envelope, duration, amplitude, delay, number of repetitions, place of simulation, produced either spatially or temporally, albeit with a much lower temporal resolution [45], [52]–[54].

Force-Feedback

Scheme

To create the sensation of touching a virtual object, the physical surface in the idealized teleoperator, in Figure 2, is now replaced by the system represented in the block diagram in Figure 6. Such a scheme for virtual object haptic synthesis was already proposed as early as 1967 for molecular docking applications [55], 1971 for computer-aided design [56], 1978 for musical applications [57], 1984 for health care [58], and 1990 for artificial reality [59].

Impedance Versus Admittance Approaches

A number of different abstractions, useful for different purposes, have been developed to represent force–feedback systems. Treating this topic properly would require a separate tutorial, and so only the basic concepts are given here.

In closed physical systems, causes and effects are arbitrary choices in general; they are a matter of perspective. However,

when two very dissimilar objects are coupled, then we can have a clear notion of causality. For example, if the internal impedance of a battery is low compared to that of its load, then we may consider that current is caused by voltage (conversely voltage is caused by a current source). Mechanically, we say that an object has high impedance if it is hard to move or deform (heavy or hard). The most fundamental principle is that only one effort (e.g., voltage or force) and flow (e.g., current or velocity) at a given point in a system can be independently controlled; when pushing on a mass with a set force, then a velocity results, and when displacing the mass with a set velocity, it responds by a force. Among other possibilities that we must ignore, the simplest and most intuitive abstraction is to model the elements of a force–feedback system as blocks with two terminals. The assumed causality is indicated by an arrow that shows which signal flows through and which appears across the terminals. We then apply Kirchoff’s laws of conservation.

In the impedance approach, we consider circuit elements that respond by a force across the terminals, as in Figure 7. A force balance equation corresponds to a closed circuit, $f_h + f_d + f_e = 0$, and mechanical coupling to common velocity (or current), $v_h = v_d = v_e$. The virtual environment thus defined specifies the forces that are to be generated by the device’s motors. With this approach, users feel the combined forces from the dynamics and statics of the device and the simulated environment in response to moving the device. Displacement is measured. If the virtual environment has zero impedance, the users feel the mass and the friction of the device itself, but their motion is otherwise unresisted. On the other hand, preventing the user to move corresponds to high-gain feedback; the virtual environment responds to small displacements and small velocities with large forces. From the standpoint of haptic display under impedance control, an ideal device has a low innate mechanical impedance and a large *dynamic range* because

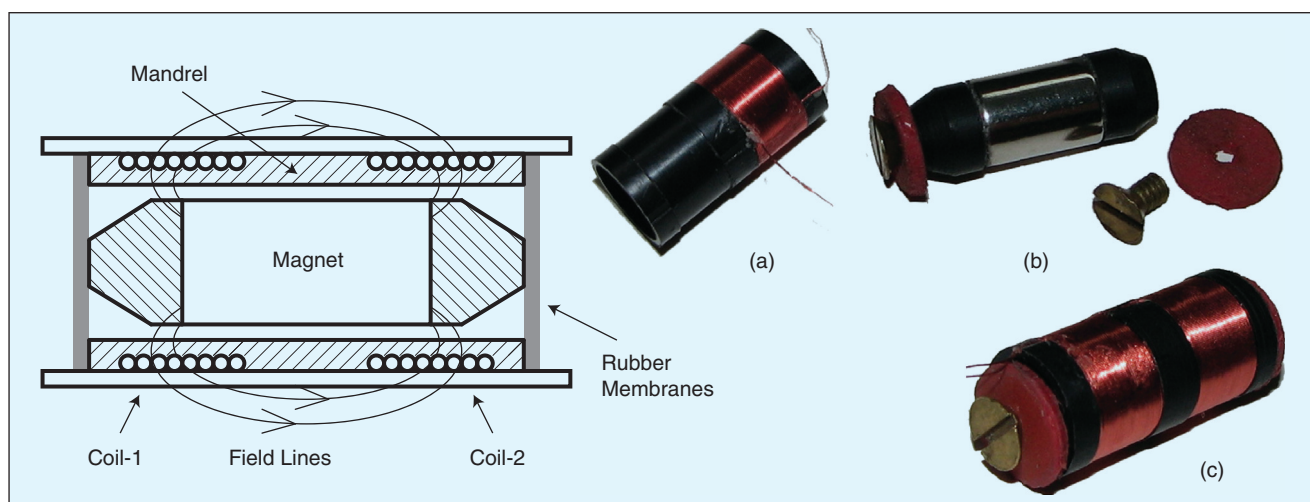

Figure 5. A magnet is suspended between two rubber membranes inside a cylindrical mandrel with two coils. The magnet is free to vibrate axially. Current flowing in the coils crosses the magnet’s magnetic field at right angle, creating an axial Lorentz force. The magnet also serves the purpose of the inertial slug [39]. Fabrication steps are as follows: (a) coils are wound around the mandrel, (b) conical spacers are glued to the magnet, (c) magnet assembly is placed in the mandrel, and (d) the actuator is inserted inside an outer tube (not shown in the pictures, shown is the cutaway section).

this allows the virtual environment alone to determine the displayed impedance.

In the admittance approach, elements respond by a displacement across the terminals. A common measured force applied by the hand onto the device is supplied to the virtual environment, $f_h = f_d = f_e$, and the elements are coupled such that now velocities add up to zero, $v_h + v_d + v_e = 0$. The device is internally controlled to track the displacements of the virtual environment and, hence, must sense force at the point of user contact and also have displacement sensors for position tracking. Users feel the displacements of the device and, hence, of the simulated environment in response to pushing on the device. If the virtual environment has zero admittance, the user feels something that does not move. To move freely requires high-gain feedback, i.e., the device must be capable of high acceleration in response to small measured user forces. An ideal haptic device under admittance control has a low admittance.

There are truly many interesting parallels and contrasts that can be drawn between these two approaches. Each method has its strengths and weaknesses. In each case, difficulties arise when the assumed causalities are violated in practice. From Figure 7, we can see that the physical device dynamics and statics represent the error of the simulation, i.e., the difference between virtually modeled and actual behavior. In the case of

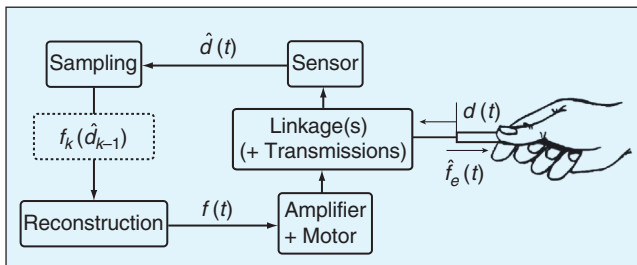

Figure 6. High-level block diagram of a haptic interface. The box with dotted line represents calculations done in a computer. If the device has multiple DoF, the step $f_k(\hat{d}_{k-1})$ includes at least four substeps: convert raw sensor readings into meaningful units, change of coordinates to map the sensor readings into coordinates in which the virtual environment is represented, map virtual environment forces into motor torques, and finally torques into raw actuator commands. See main text for more detail.

impedance-type simulations, this error is the open-loop device dynamics. It is not typically corrected for. For admittance-type simulations, the device must be run in closed loop (i.e., it relies on sensed displacement to track the virtual environment) and so its nonideal dynamics further include those of a control algorithm. Hence, in both cases, but for completely different reasons, their electromechanical design is critical.

In this tutorial, we focus on the impedance approach for several reasons. The hardware is simpler to design and commission, and this is often true of the software as well. The impedance formulation is also inherently more appropriate when unimpeded motion in free space is an important aspect of the simulation. In the remainder of this tutorial, the impedance approach is assumed, and we now revert to the real system depicted in Figure 6.

The Ideal Versus the Reality: Inertia, Structural Dynamics, and Losses

It is apparent from the diagram in Figure 6 that a haptic simulation is subject to a number of approximations. The first offending link in the chain is the electromechanical device itself. It can be neither massless nor infinitely rigid (see [60] and “Device Performance”).

A few calculations give a sense of the orders of magnitude involved. As a baseline, let us first consider a high quality dc motor frequently employed in haptic devices (model RE25, Maxon Motors AG, Sachseln, Switzerland; see also “The Haptic Knob” section). If a 100-Hz force signal is commanded in open loop by driving a 100-Hz current through this motor, then due to motor inertia the maximum torque available can

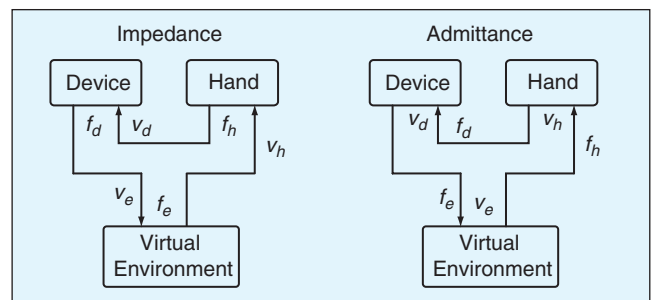

Figure 7. Abstracted mechanical circuits.

Haptic Device Performance

The important facts and methods for force feedback device characterization are detailed below. [60], [154]–[157].

Rule 1: Since a haptic device is a bidirectional transducer, the place where measurements are made is crucially important. From the system’s view point, a response is measured between the motors and the displacement sensors. From the user’s perspective, however, the relevant response is found where the device is touched; it is not where the actuators are connected.

Rule 2: As in any system, the load should be specified and controlled since the response and the noise critically depend on it.

Rule 3: If forces are measured, the force sensor should be stationary, i.e., clamped to the ground. If not, one should make sure that inertial terms caused by fast movements can be neglected, or else they must be compensated for.

Rule 4: Sensors must have sufficient resolution. (For instance, a 400-count encoder cannot resolve oscillatory movements of an unloaded RE25 motor beyond 10 Hz.) When the movements are fast and small, the accelerometer is the preferred option.

Rule 5: Haptic devices typically exhibit several types of nonlinearities. One should identify the main sources of nonlinearities: saturation, motor hysteresis, friction, backlash, and nonlinear structural effects.

create peak-to-peak oscillations of only 0.025° . This illustrates the inescapable fact that electric motors act as force *transducers* near dc only; during transients and fast oscillations, the entire available torque is required simply to move the motor itself. In practice, a motor often drives a linkage through a transmission that further reduces these figures by at least one order of magnitude. Consider now that a true force transducer would require the device to be at least ten times lighter than the load, the same way that the impedance of a voltage source should be much lower than that of its load. This is very difficult to achieve. The effective inertia at the tip of the best-performing device of SensAble, the PHANTOM 1.0 (SensAble Technologies, Woburn, Massachusetts) is 75 g, at least one order of magnitude too heavy when loaded by a finger [61].

The second basic difficulty is device *structural dynamics*. It is difficult to avoid structural modes in the form of resonances and antiresonances that can be as low as 10–30 Hz. Attempts to reduce inertia by feedback are fundamentally limited, as just seen, by saturation and structural dynamics.

One should not conclude that force-feedback devices cannot work! Simply be aware of their limitations [60]. Fortunately, many useful haptic simulations operate near dc, i.e., under about 10 Hz. Such is the case of interaction with deformable bodies, as in most surgical simulations. As far as textures are concerned, it can be shown that devices of the class of the PHANTOM 1.0 do not produce textural effects that resemble, even remotely, to what was specified by the programmer [22]. However, when a fast haptic signal is required, a response determined by the hardware rather than by what is commanded through a program might, perceptually, just be good enough. If not, researchers have proposed work-arounds, which all have in common correcting the displacements of the handle either in closed loop with a fast second stage for textures [62] or in open loop by input shaping for increasing the realism of shocks via acceleration matching [18].

Losses are an important part of the dynamics of haptic devices. Of mechanical losses, two are relevant to haptic devices. The first arises from backlash in the joints, which is always present in ball-bearings. Since these losses are related to the rate of micro-collisions during oscillations, classically it can be modeled as equivalent damping [63]. The second is friction in the motor brushes, bearings, and in the transmissions. Cable capstan-driven transmissions (see next section) exhibit a special type of friction with smooth transitions due to the

distributed nature of the many interstrand contacts in a cable, which for small movements create nearly elliptical hysteresis loops (see [64] for an example). Electrically, the most significant are the ohmic losses in the motors further discussed later. On one hand, losses should be minimized, but on the other, they play a crucial role for stabilization as we will see in the section on control issues.

Kinematic Structure

For haptic interfaces with multiple *degrees of freedom* (DoF; see Figure 8 for examples) force-feedback devices are built around a kinematic structure that connects sensors and actuators to some type of handle. These are generally constructed as *parallel* rather than *serial linkages*; because of actuator limitations, this maximizes strength, minimizes inertia, and raises the first natural vibratory mode that determines the usable response bandwidth [65]. These same priorities shaped the early master-arm designs [66]. For two DoF, a *five-bar mechanism* is the only choice, although it appears in spherical (e.g., joystick types [67]) and planar configurations (e.g., computer interaction [19]). As the number of DoF goes up, the number of possibilities explodes. Further expanding the design space, each joint can be powered with either of two predominant methods, cable *capstan* or *direct drive*, and the number of sensors and actuators may differ [68].

Declaring a design to be optimal is rather difficult because its properties are tightly intertwined [15]: uniform kinetostatic response [71], [72], workspace [73], force [74], dynamics [75], mass/inertia [76], structural transparency [69], [77], and other considerations such as intended function, cost, bulk, visual aspect, and safety considerations are all aspects that depend on each other. This may explain why several practical designs adopt kinematic structures ranging from partially parallel to

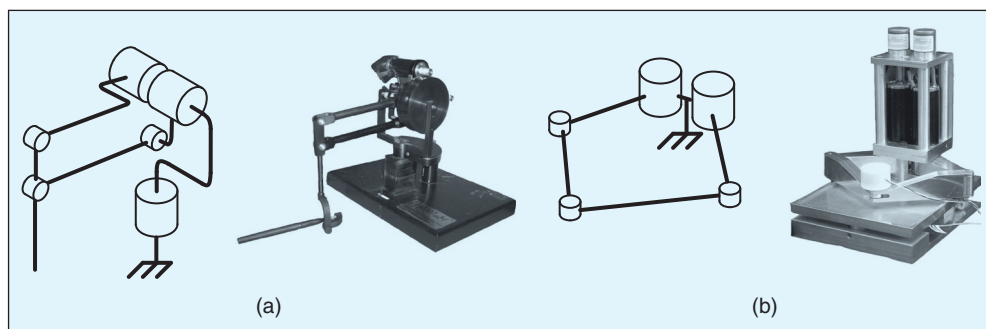

Figure 8. Examples of kinematic structures. (a) The kinematic structure of a PHANTOM 1.0 device. It has a five-bar regional structure that provides two DoF by deforming as a parallelogram; because of its relative link lengths, the action of the two motors causes largely decoupled vertical and horizontal motions of the end effector. The whole structure swivels around a vertical axis under the action of a third motor. Being a hybrid structure [14], this device employs capstan torque-amplifying transmissions combined with a clever distribution of the moving parts, and the center of mass is invariant and so the system is statically balanced. These are useful properties for haptic interfaces [69]. (b) The Pantograph device is made of a five-bar mechanism having two DoF [70]. Since the joint axes are parallel, the tip moves in a plane, and hence the name planar mechanism. The actuators are stationary and drive the links directly. Figure 11 also shows a five-bar mechanism frequently employed to make joysticks. But in this case, all joint axes meet at a point and have two angular DoF and are called a spherical five-bar [67].

fully parallel in which both cable and direct drives are represented [14], [69], [78]–[85].

For the purpose of this article, a special class of kinematic structures worth further comment includes the string-based devices because of their relative ease of implementation. Effective and structurally transparent multi-DoF force-feedback devices with large workspaces can be made without any linkages. Instead a thimble or a handle is driven directly with a set of taut cables [86]. Several designs have emerged from this idea for different purposes and at different scales, which is a testimony to their practicality [87]–[90].

Sensors

Referring back to Figure 6, again assuming perfect mechanics, the next object of examination is the sensor. For an impedance-controlled environment, device position must be sensed. Velocities (and sometimes acceleration) are often used in virtual environment computations and control stabilization as described below, but they can be derived from positions to a certain extent. The most common position sensor is the optical *quadrature incremental encoder*. Haptic devices also sometimes use *Hall effect* analog sensors. Whether sensors are analog or digital (e.g., incremental encoders), the dominant characteristic is resolution, the number of counts for incremental encoders and the noise level for analog sensors. It has been found that resolution is not always important. When poking onto a wall, sensor resolution, per se, has no direct effect on stability but interferes with time sampling to create undesirable behaviors [91], as further discussed below. When the interaction consists of tracing a virtual surface, however, resolution is important to display fine textures and to precisely detect movement reversals when simulating friction [22], [23].

Actuators

We have already seen that the actuator of choice is the dc motor because its torque is directly proportional to current, thus suiting it to impedance control configurations. These motors come in several kinds of which three are most used in haptic devices. They all use Lorentz law to generate force from a current interacting with a magnetic field but differ in the geometry of their respective electric and magnetic circuits. The permanent magnet wound dc motor is the most common (and least expensive), deriving its name from the fact that the armature is wound around a rotating soft iron core, part of the magnetic circuit (Gramme's machine). The second type is the so-called coreless motor, so called because current flowing through rotating copper or aluminum windings interacts with the magnetic field inside the air gap of an entirely fixed magnetic circuit. The third type is the brushless motor, so named because the magnetic field is provided by rotating magnets while the armature is stationary, thus eliminating the need for brush commutation. These primary distinctions are highly relevant to haptic interface design [92].

Previously, we saw that the fundamental qualities of a haptic device should be to be both light and strong. In other words, acceleration must be maximized. It is known that the coreless motor, since it minimizes the mass of rotating

material, typically performs better than the wound and brushless motors in this respect. Moreover, the latter types often suffer from *torque ripple*, *cogging*, and *hysteresis*—three types of nonlinearities that are detrimental to providing precise force-feedback. Finally, the inductance of coreless motors is also smaller than that of the other motor types that contribute to minimizing their electrical time constant. On the other hand, coreless motors tend to exhibit more internal structural dynamics than the wound motors, and so wound motors tend to give a more damped feel to the simulations. Brushless motors are less prone to overheating than the other two types.

Amplifiers

The amplifier, which translates a low-power signal into an amplified signal able to drive a motor, is an integral component of a haptic interface system. It is often stated that the preferred type of amplifier regulates current as opposed to voltage (*current versus voltage drive*), because current regulation minimizes the effect of the motor's electrical dynamics resulting from its inductance. However, the electrical time constant of a coreless motor is actually quite small, by for example 100 μs , for the model already mentioned, and so it is reasonable to neglect it. It is also sometimes mentioned that the purpose of current regulation is to counteract the viscosity caused by the back-EMF of a shunted motor. The damping coefficient corresponding to this effect for the same motor is only $0.21 \text{ mN} \cdot \text{m} \cdot \text{s} \cdot \text{rd}^{-1}$. This is small for the speeds at which haptic devices operate, unless the transmission uses a speed reduction/torque amplification mechanism, since in this case, motor damping and inertia seen from the handle are increased by the square of the transmission ratio.

In practice, the overriding benefit of current regulation is to compensate for the sudden resistance changes, due to brush commutation as the motor rotates, and slow resistance changes, due to variation of the winding temperature. Without it, at high torques, irregularities can be felt as the brushes slip from one collector segment to the next. It is also highly desirable that the electrical bandwidth be far larger than the mechanical response of the device, something which is harder to guarantee with other types of motors.

Finally, there are two main types of amplifiers: switching pulse with modulation (PWM) amplifiers or analog amplifiers. PWM amplifiers can introduce unwanted dynamics if their design is not finely tuned to the load. They also tend to radiate electric and acoustic noise. On the other hand, they are often cheaper for an equivalent power and are, by principle, more efficient than their analog counterparts. Analog amplifiers tend to be more precise and quieter but require cooling. Both types are capable of voltage or current regulation if their design has allowed it. The careful designer should be aware of amplifier dynamic characteristics when driving a particular motor.

Control Issues

Referring again to Figure 6, the computed part of a force-feedback haptic simulation comprises sampling the sensors, evaluating a virtual model that in an impedance-type formulation specifies the forces that should be displayed in response to

the tool's measured displacements, and finally reconstructing an analog signal from the digital command with the amplifier as destination.

As alluded to earlier, the simulation of probing or manipulating a virtual object can involve several types of phenomena. They present challenges to satisfactorily simulate a desired virtual environment. In this subsection, we briefly survey some of these phenomena, moving from the simplest to increasingly complex, and in the next subsection, we address signal reconstruction. Yet, our discussion touches only peripherally on the very large topic of simulation models themselves described in the next section.

Mechanics That Can Be Simulated

The most basic virtual model is built on the assumption that the virtual object being touched is firmly anchored to a fixed frame relative to the tool and that no slip occurs between the tool and the object. In a nutshell, the tool-object interaction is just indentation, which is when a tool penetrates an object by a small amount. This can be further subdivided into interactions between a hard tool and a hard object [93]–[96], between a hard tool and a soft object [97], [98], and between two soft objects [99]. In all of these cases, the forces of deformation are the foundation of the interaction's simulation. But of course, there can be other kinds of forces.

At the next level, we can permit a sliding contact between the tool and the object. Interestingly, forces that then arise are also due to deformation but of a combined elastic and plastic nature, and they can be computed as such [100], [101]. When the simulated surfaces are not smooth, small oscillations should also result from the sliding of the parts. Basic methods to achieve all these effects are summarized in recent surveys [23], [102], [103]. Next, the assumption of fixation for the simulated object can be relaxed. When the object is allowed to translate, spin, and bounce as well as deform, inertial forces must be added to the equation [104]–[107]. One may also consider interaction with fluids [108], or both solids and fluids [109], or the forces involved in separating surfaces [110], [111].

Sampling and Quantization: Cross-Cutting Issues

All these possibilities—and more—are what are symbolized by the expression $f_k(\hat{d}_{k-1})$ in Figure 6, where for simplicity, the symbols may represent scalar or vector quantities in the case of complex environments. The hat on the variable d expresses the approximate nature of the knowledge of the tool displacement and the differing subscripts, k and $k - 1$, representing different time steps of the discrete simulation. These two aspects, which at first sight could be viewed as unimportant details, actually consolidate two cross-cutting issues common to all of the cases just listed, from the simplest one-dimensional simulation of a spring to a mechanical environment of arbitrary complexity. Both the space and time approximations, which in many robotic control problems can be ignored, turn out to have severe consequences in the case of haptic simulations. For a long time, it was noted that haptic simulations tend to oscillate. This is because the system in Figure 6 is, in essence, an unstable system. A simple numerical example makes this clear.

Let us suppose that we simulate a relatively soft spring of stiffness $\sigma = 1,000 \text{ N} \cdot \text{m}^{-1}$ (a far cry from the kind of stiffness created by a hard surface) with display hardware that has an effective inertia of $m = 0.1 \text{ kg}$. Because of the update delay, the restoring force f_k of the virtual spring lags behind the measured displacement \hat{d}_{k-1} , with the consequence that, during spring unloading, it is always too large. Equate the virtual potential energy of the simulation, i.e., that stored in the virtual spring with the kinetic energy of the device after one time step: $(1/2)m(v_k + \Delta v)^2 = (1/2)\sigma(d_k + \Delta d)^2$. Solving this for Δv and comparing it with the energy balance at the beginning of the time step, to a first order gives $\Delta v = \sqrt{\sigma/m}\Delta d$. If there is nothing in the system to dissipate this spurious energy, the simulation would actually accelerate the device considerably at each time step. Each displacement measurement error is magnified into a velocity error by a factor $\sqrt{\sigma/m}$. In our example, this factor is 100 s^{-1} . If the haptic simulation runs at $1,000 \text{ Hz}$ and if we unload the simulated spring at a rate of $v = 0.1 \text{ m} \cdot \text{s}^{-1}$, then $\Delta d = 0.0001 \text{ m}$ and thus $\Delta v = 0.01 \text{ m} \cdot \text{s}^{-1}$. Even with the conservative figures that we have picked, in a 0.1 s interval, the device doubles its speed! Quantization tends to also create difficulties of this kind, but they are less severe, in part, due to the time-independence nature.

Stability Issues

Actual devices have nonlinearities such as actuator saturation, stick-slip due to friction, backlash in the joints, shifting structural modes, and so on. The simulated function f_k itself is rarely linear and may not even represent a conservative system. The simple situation just depicted where the system simply explodes rarely occurs in practice. Instead, one often observes cyclical behaviors, or *limit cycles*, of various frequencies. This problem has caused a considerable amount of concern since the very beginnings of haptic simulations [112] and can be very frustrating when attempting to implement any type of haptic simulation. Most of the known methods for system stability analysis have been applied to this problem: Routh-Hurwitz criterion [113], [114], small gain theorem [115], Jury criterion [116], deadbeat control [117], time domain passivity [98], [118]–[121], Llewellyn's stability criterion [122], describing function analysis [91], [123], port-Hamiltonian systems [124], and Lyapunov analysis [123].

Of course, a common thread underlies all these works, regardless of the approach adopted for analysis. As illustrated earlier, this thread is rooted in the physics of closing a high-gain discrete-time loop around an imperfect electromechanical system. The first study to articulate this question precisely is reference [115]. There, a *passivity* condition of the form $\mathcal{B} \geq (1/2)\sigma\mathcal{T}$ is derived, where \mathcal{B} is the physical viscous damping coefficient of the device and \mathcal{T} the sampling period. To gain physical insight into this expression [23], one may calculate the energy lost to viscous damping during one sample period and compare it to the energy error due to sampling. Likewise, the energy lost to dry friction can be compared with the energy error due to quantization, yielding: $f_f \geq (1/2)\sigma\delta$ where f_f is the dry friction force and δ the position measurement quantum. These expressions state what is obvious in hindsight: as

the sampling period gets smaller and the sensors more precise, the simulation can approach the continuous case. No matter how well a device is constructed, there are always losses, and however small, one can live with finite sampling and resolution [98]. Too much stability obtained by having a device with a lot of electrical and mechanical losses (ohmic losses, viscous damping, friction) destroys the realism of a simulation, and not enough destroys it too; the name of the game, then, is to always keep things marginally stable!

Keeping Simulations Marginally Stable by Updating Fast

Practically, these expressions also say that it is always better to sample faster and to increase the resolution of the sensors up to the point where the inaccuracies due to sampling and quantization are masked by the losses present in any electromechanical system. This, therefore, consolidates the basic tradeoffs faced by the designers of force-feedback haptic simulation systems [125]. If there are more losses, then one can get away with lower rates and coarser sensors, but this evidently translates into lower fidelity in time and space. One might have to lower expectations in terms of the details being conveyed (corners, textures). Dynamic range (from free movement to hardness) as well as various types of artifacts may decrease the realism of the simulation or simply reduce the range of possibilities being afforded.

As a result, software control approaches have been proposed to deal with these tradeoffs if the simulation computations are too onerous to allow for a fast update rate. Software must then be organized to decouple the fast, closed-loop computations from those that do not require a rapid update [97], [126]–[129]. This approach ties in with multirate techniques [130]–[132].

Keeping Simulations Marginally Stable by Computational Damping

Another approach is to damp the system by feedback. Unfortunately, this approach has limits for the following two reasons. The first is the need to estimate velocity directly from position measurements. By principle, the device is permanently subject to disturbances, and so velocity observation can be effective but only in low frequencies [133]. The second limitation is also due to the delay incurred in the feedback, which also is destabilizing [125].

A small numerical example is worthwhile for seeing that the requirements are again humbling. Suppose that a device can resolve a highly optimistic 10- μm displacement and that the sampling rate is 1 kHz. Then, the smallest velocity quantum that can be detected is $0.01 \text{ m} \cdot \text{s}^{-1}$. A velocity signal should contain at least ten quanta to be of any use, which puts the smallest velocity at which damping can be applied at $0.1 \text{ m} \cdot \text{s}^{-1}$, a rather large velocity, even in these optimistic conditions. Worse, if position measurements are delayed by at least one sample period, velocity measurements are delayed by at least two and often more, since they are derived from finite differences of past samples plus possible additional smoothing. Thus, raising computational feedback gains invariably causes limit cycles. More elaborate velocity estimators can improve the results considerably but do not eliminate these instabilities [134], [135].

To express this fundamental tradeoff, the passivity condition $\mathcal{B} \geq (1/2)\sigma\mathcal{T}$ can be augmented to become $\mathcal{B} \geq (1/2)\sigma\mathcal{T} + b$ where b is the computational damping demanded. Nevertheless, a popular approach is to modulate damping from cycle to cycle, a method known as time domain passivity control [120], [136]. It has been shown to be effective if the device has sufficient inherent mechanical losses, but for similar reasons, it can create undesired artifacts [137].

Other Approaches to Keeping Simulations Marginally Stable

Other approaches have been explored. Discrete-time signal processing techniques have been proposed to compensate for the effect of delay using a prediction/correction method [118]. But here again, what is gained in terms of minimizing the effect of delay is lost in the possible creation of high-frequency artifacts. Recent hardware approaches share the goal of introducing programmable physical damping [137]–[139]. Finally, feeding forces in open loop is an option, i.e., applicable in appropriate cases [140].

As can be appreciated, this question is quite central to the field of force-feedback haptic simulations, because if not addressed effectively, it can derail the best-conceived projects in all their other aspects. It has already and will continue to generate a stream of engineering challenges and innovations both for hardware and software.

Reconstruction

We have examined the effects of linkages and transmissions, motors and amplifiers, sensor resolution, and time sampling on a force-feedback haptic simulation. The last block that remains to be discussed is the reconstruction block in Figure 6. It is, by far, the least discussed of all the components of a force-feedback system, and yet it can play a critical role. The most straightforward reconstruction technique is the *zero-order hold*, and this is a good choice for feedback-controlled systems. Good results require the use of an appropriate low-pass filter to prevent aliasing, and unwanted vibratory modes should not be excited. The topic of reconstruction has received little attention to date in haptic simulation; the natural dynamics of the amplifiers, motors, and linkages of a device are typically assumed to be able to play this role adequately. However, when a device is destined to operate at high frequencies where it no longer behaves like a rigid body, then the presence or absence of a properly designed low-pass reconstruction filter can have a dramatic effect on the result [22].

An Interesting Device: The Haptic Knob

Many of the questions that have been discussed in this article can be researched with the device depicted in Figure 9, or more generally with one DoF devices [141], because it is capable of both vibrotactile stimulation and force-feedback. It is an uncomplicated place to begin. We therefore use the knob as a capstone example to discuss the practical applications of these issues; and at the same time introduce some basic software components.

Hardware

We have described two types of transmissions typically used in designing haptic interfaces: the capstan/cable drive and the direct drive. Both can easily be experimented with [142]–[144]. We also mentioned two major types of motors: wound and coreless. Table 1 lists the expected characteristics of a haptic knob built with one of the commonly used dc motors, sourced with an attached optical encoder. The two motors have almost the same form factor and the same nominal voltage.

The other components of an experimental system include a computer, say a PC with appropriate input-output (I/O) boards, having the ability to read the encoder signals and to output a single analog voltage. Note that it is not necessarily the most expensive nor the most sophisticated I/O boards that give the best result. Delay is a determinant factor for precise and stable haptic simulation and, therefore, plain and fast designs are preferable over slower, complex, multifunction designs. Other possibilities include single-board computers linked to a host or dedicated I/O boards connected to a computer parallel port or other appropriate standard I/O channel.

Amplifiers can be procured ready-made from commercial sources. With some engineering effort, it is also possible to build them rather easily from monolithic power-chips such as the LM12CL or LM675 (<http://www.national.com/mpf/LM/LM12CL.html>, [LM675.html](http://www.national.com/mpf/LM/LM675.html)) or Apex Microtechnology devices (<http://portal.apexmicrotech.com/>). Both voltage and current drives can be built around these chips.

Software

Real-time software is needed to experiment with haptic force-feedback or to develop an application. Figure 10 shows a bare-bones diagram of a force-feedback haptic interface software diagram. It is described for a general device in which the symbols could designate vector quantities representing forces and torques for a multi-DoF system. With the haptic knob, we have one angle and one torque.

Boxes in thin black lines indicate steps that are performed sequentially in a hard real-time thread. Hard real-time means that computations must run at a regular rate and terminate within a predictable time interval before the next update. Regularity is required since a fixed rate is assumed by both theoretical and practical considerations. Updates that jitter or occasionally miss samples create clicks and pops in the simulation if the hardware is responsive or even destabilize the system in the worst case. One must exercise caution when using real-time extensions to general purpose operating systems. (Linux real-time frameworks have given excellent results.) As seen earlier, rates as high as 10 kHz may be needed. Precision should then

be of a few microseconds. If the simulation is soft or if the device is unresponsive, 100 Hz may suffice.

Step 1 converts raw encoder counts into physical units, such as radians, if the device uses encoders. If it uses analog sensors (not represented) the counters are replaced by analog-to-digital conversion associated with an optional oversampling plus averaging step to reduce noise. The determination of parameters a and b (denoted as scalars by abuse of notation)

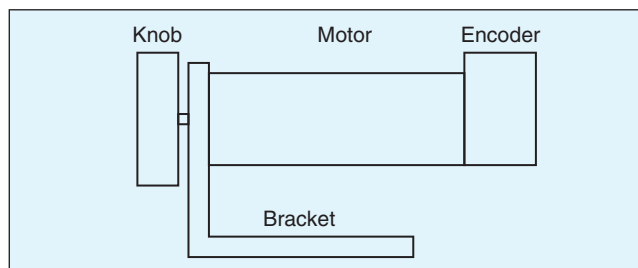

Figure 9. One DoF force-feedback haptic interface.

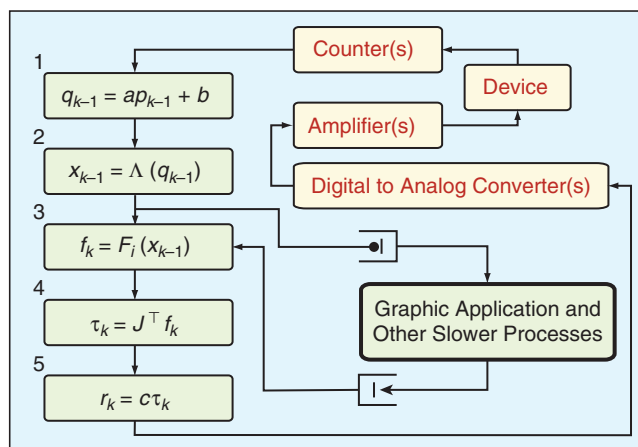

Figure 10. Bare-bones software architecture for a force feedback haptic interface. There is at least a hard real-time thread running at high rate to update forces (thin lined boxes), a slower soft real-time thread to execute computations that do not require fast update rates (thick lined box), and appropriate communication between the two processes. Hardware components are indicated in grey.

Table 1. Expected characteristics of a haptic knob constructed with a wound Pittman model 8693 motor (19 V) or a coreless Maxon model RE25 motor (graphite brushes, 18 V).

Characteristic	Unit	Wound	Coreless
Inertia (not including the inertia of the knob)	$\text{kg m}^2 \times 10^{-6}$	1.6	0.95
Dry friction	$\text{N m} \times 10^{-3}$	2.1	–
Viscous damping (when short-circuited)	$\text{N m s rd}^{-1} \times 10^{-3}$	0.15	0.21
Peak torque	$\text{N m} \times 10^{-3}$	150	175
Continuous torque	$\text{N m} \times 10^{-3}$	22	23
Inductance	mH	1.5	0.15
Terminal resistance	Ω	2.6	1.26
Thermal time constant (motor/windings)	s	720/–	910/12
Encoder resolution (off-the-shelf)	CPR	1024	1000
F0 (measured when clamping down the output shaft)	Hz	–	600

A number of different abstractions, useful for different purposes, have been developed to represent force-feedback systems.

may require a prior calibration step. Step 2 computes the direct kinematic problem, $\Lambda(q)$, if the device has more than one DoF. Step 3 is the computation of the virtual environment proper and may rely on model updates from slower-running threads as indicated. Step 4 multiplies the desired end-effector forces (and potentially torques) by the transposed Jacobian matrix of Λ to obtain the desired joint torques, i.e., the torques that are required at the motor joints to produce those endpoint forces. Step 5 transforms these torques into representations suitable for digital-to-analog conversion. In our single-DoF system, the Jacobian is a scalar gain that might include, for example, the knob radius, depending on the anticipated user grip.

The box with thick black lines contains computations that can be performed at a much lower rate, say the 30 Hz required for compute-intensive graphics components. Since the consequences of missing updates are not as severe as when running the haptic loop, we may be satisfied with soft real-time. Here, we may include code related to other types of human-computer interaction such as mouse inputs. Proper interprocess communication must be established between the hard real-time thread and slow or nondeterministic events. The symbol \boxminus represents communication with data loss (implemented, for instance, with shared memory plus semaphore interlock) and the symbol \boxplus represents communication without loss of data (implemented, for instance, with a first-in first-out queue). It is also possible to implement this scheme using multiple CPUs with communication protocols that can support these functions. A natural design is, of course, to dedicate a processor to the hard real-time thread. Dedicated groups have recently created open-source software

that operates along these lines for interaction with three-dimensional virtual objects [145], [146] and for allowing fast communication between disparate types of machines [147].

Notice how data loops around the Step 3, $f_k = F(x_{k-1})$. In the “Updating Fast” section, we noted the necessity to organize software such that force update computations be performed at a required rate but other computations, such as graphics, need not to be performed at a rate higher than necessary. This loop expresses a strategy whereby the slower computations acquire the position of the haptic device in virtual space at a much lower rate than they are available (a down-sampling process with loss of data) and supply back parameters or entire functions that are valid locally in space or in time (an up-sampling process without data loss). Step 3 must therefore perform interpolation in space, or in time, according to the methods mentioned in the “Updating Fast” section to reconstruct samples between slow updates.

At this point, your haptic knob is ready to roll. All, i.e., left is to program your choice of interesting behaviors within Step 3 of your simulation algorithm and start experimenting [143].

A Simple Surface Display

In this section, we describe a haptic surface display, i.e., simple to make. Haptic shape sensations can be generated when touching a flat surface, i.e., controlled to rotate around a fixed point. A mechanism that can conveniently be employed is the spherical five-bar linkage illustrated and described in Figure 11. If the point around which the plate rotates is inside the finger by a few millimeters, then the plate rolls on the finger but the finger does not move significantly. Within curvature limits, the user feels the shape of a virtual object if the plate is servo-controlled to be tangent to its surface [148]. There are two modes of operation.

In the first mode, the device is mounted on another non-motorized mechanism to allow free exploration, say in a plane. The movements in the plane are measured to define a point in virtual space. The second mode does not require any additional special purpose hardware. Movements in virtual space

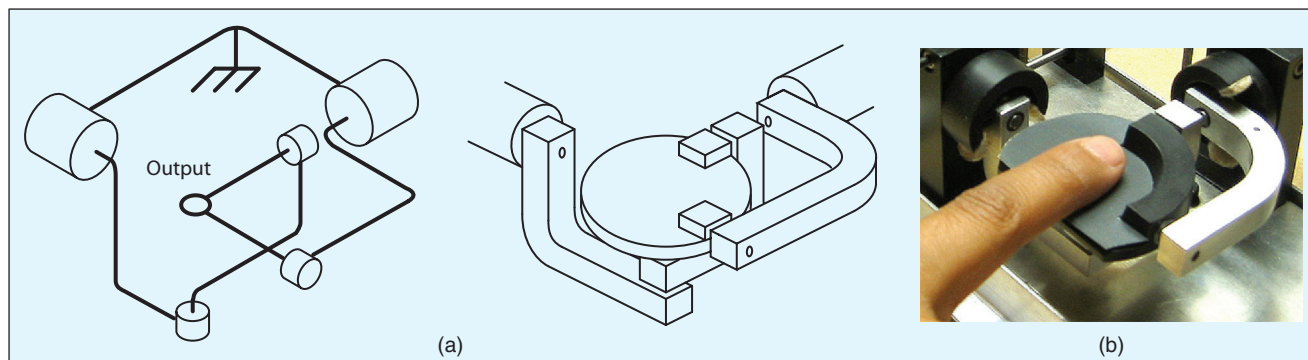

Figure 11. We earlier encountered the spherical five-bar mechanism, often used to make force-feedback joysticks. For this purpose, a vertical handle is attached to the output link in the kinematic diagram (a) [67]. In this mechanism, all the joint axes meet at one point symbolized by the black circle, and hence the handle rotates with two angular DoF around this point. To make a surface display, the diagram in the middle shows a practical realization such that the point around which the plate rotates is slightly inside the user’s finger (b). In the experimental realization of the Morpheotron, we have used low-power dc motors with precision gear heads run under proportional-integral-derivative (PID) servo [148]. Although we have not experimented first hand with this option, a working device could certainly be realized with off-the-shelf radio-controlled servo drives for hobby applications.

can be obtained from any ordinary input device, of which many kinds exist [149], in which case the feeling of shape is also effectively obtained during exploration [148].

The control software is therefore not different from any ordinary robotic device with appropriate changes of coordinates and servo control loops. The reference trajectory is obtained by forcing the virtual interaction point to stay on the surface of a virtual object and by finding the normal to the surface at this point. The overall performance of the device is linked to the precision and tracking performance of the servo mechanism. The other surface display haptic devices introduced in the "Surface Displays" section all include the key aspects of classical robotic manipulators in their design.

Conclusions

In this first part of our series, we have introduced haptic interfaces, the principles on which they operate, and how relatively simple devices can be commissioned for experimentation. We have examined vibrotactile transducers and have further expanded on force-feedback devices because of their respective dominance today, the former because of their simplicity, and the latter for their flexibility and range of applications. Distributed tactile transducers are still today at their development stage with very few examples of commercial developments. Surface displays and their many variants could develop into a new breed of haptic displays.

In the recent years, surveys emphasizing aspects of haptic interfaces other than those explored in this tutorial were published and may be consulted by the readers [102], [150]–[152].

There is more to haptic interaction than simulating interaction with objects that could exist [153]. In the second part of this tutorial, we will explore research in haptic interaction design and describe more fully contemporary applications.

Acknowledgment

The authors would like to acknowledge the support of the Natural Sciences and Engineering Council of Canada.

Keywords

Haptic interfaces, vibrotactile feedback, force feedback, surface displays, tactile displays.

References

- [1] C. E. Sherrick, "Basic and applied research on tactile aids for deaf people: Progress and prospects," *J. Acoust. Soc. Am.*, vol. 75, no. 5, pp. 1325–1342, 1984.
- [2] P. Brooks and B. Frost, "Evaluation of a tactile vocoder for word recognition," *J. Acoust. Soc. Am.*, vol. 74, no. 1, pp. 34–39, 1983.
- [3] R. H. Gault, "'Hearing' through the sense organs of touch and vibration," *J. Franklin Inst.*, vol. 204, pp. 329–358, 1927.
- [4] R. H. Cook, "An automatic stall prevention control for supersonic fighter aircraft," *J. Aircraft*, vol. 2, no. 3, pp. 171–175, 1965.
- [5] S.-Y. Kim, K. Y. Kim, B. S. Soh, G. Yang, and S. R. Kim, "Vibrotactile rendering for simulating virtual environment in a mobile game," *IEEE Trans. Consum. Electron.*, vol. 52, no. 4, pp. 1340–1347, 2006.
- [6] H. Z. Tan, R. Gray, J. J. Young, and R. Traylor, "A haptic back display for attentional and directional cueing," *Haptics-E*, vol. 3, no. 1, 2003.
- [7] R. W. Lindeman, A. J. L. Sibert, A. E. Mendez-Mendez, A. S. Patil, and A. D. Phifer, "Effectiveness of directional vibrotactile cueing on a

- building-clearing task," *Proc. SIGCHI Conf. Human Factors in Computing Systems*, New York, NY, ACM, 2005, pp. 271–280.
- [8] L. M. Brown and T. Kaaresoja, "Feel who's talking: Using tactons for mobile phone alerts," *Proc. SIGCHI Conf. Human Factors in Computing Systems, CHI'06: Extended Abstracts on Human Factors in Computing Systems*, New York, NY, ACM, 2006, pp. 604–609.
- [9] A. Chan, K. E. MacLean, and J. McGrenere, "Designing haptic icons to support collaborative turn-taking," *Int. J. Hum. Comput. Stud.*, to be published.
- [10] K. MacLean and M. Enriquez, "Perceptual design of haptic icons," in *Proc. Eurohaptics*, Dublin, Ireland, 2003, .
- [11] D. A. Lawrence and J. D. Chapel, "Performance trade-offs for hand controller design," in *Proc. IEEE Int. Conf. Robotics and Automation*, 1994, pp. 3211–3216.
- [12] K. L. Johnson, "Contact Mechanics," #,}. Cambridge, MA: Cambridge University Press, 1985.
- [13] L. B. Rosenberg and B. D. Adelstein, "Perceptual decomposition of virtual haptic surfaces," in *Proc. Symp. Research Frontiers in Virtual Reality*, 1993, pp. 23–26.
- [14] T. H. Massie and J. K. Salisbury, "The PHANToM haptic interface: A device for probing virtual objects," in *Proc. ASME IMECE Symp. Haptic Interfaces for Virtual Environments and Teleoperator Systems*, 1994, vol. 55-1, pp. 295–299.
- [15] V. Hayward, J. Choksi, G. Lanvin, and C. Ramstein, "Design and multi-objective optimization of a linkage for a haptic interface," *Advances in Robot Kinematics*, J. Lenarcic and B. Ravani, Eds. Norwell, MA: Kluwer, 1994, pp. 352–359.
- [16] A. Okamura, J. T. Dennerlein, and R. D. Howe, "Vibration feedback models for virtual environments," in *Proc. IEEE Int. Conf. Robotics and Automation*, 1998, vol. 3, pp. 2485–2490.
- [17] D. A. Lawrence, L. Y. Pao, A. M. Dougherty, M. A. Salada, and Y. Pavlou, "Rate-hardness: A new performance metric for haptic interfaces," *IEEE Trans. Robot. Autom.*, vol. 16, no. 4, pp. 357–371, 2000.
- [18] K. J. Kuchenbecker, J. Fiener, and G. Niemeyer, "Improving contact realism through event-based haptic feedback," *IEEE Trans. Visual. Comput. Graph.*, vol. 12, no. 2, pp. 219–230, 2006.
- [19] C. Ramstein and V. Hayward, "The pantograph: A large workspace haptic device for a multi-modal human-computer interaction," in *Proc. SIGCHI Conf. Human Factors in Computing Systems*, 1994, pp. 57–58.
- [20] F. Avanzini and P. Crosato, "Integrating physically based sound models in a multimodal rendering architecture," *Comput. Animation Virtual Worlds*, vol. 17, no. 3/4, pp. 411–419, 2006.
- [21] J. Sreng, A. Lecuyer, C. Megard, and C. Andriot, "Using visual cues of contact to improve interactive manipulation of virtual objects in industrial assembly/maintenance simulations," *IEEE Trans. Visual. Comput. Graph.*, vol. 12, no. 5, pp. 1013–1020, 2006.
- [22] G. Campion and V. Hayward, "Fundamental limits in the rendering of virtual haptic textures," in *Proc. First Joint Eurohaptics Conf. and Symp. Haptic Interfaces for Virtual Environment and Teleoperator Systems*, 2005, pp. 263–270.
- [23] V. Hayward, "Physically-based haptic synthesis," *Haptic Rendering: Foundations, Algorithms and Applications*, M. Lin and M. Otaduy, Eds. A. K. Peters, to be published.
- [24] K. Hirota and M. Hirose, "Development of surface display," in *Proc. IEEE Virtual Reality Annu. Int. Symp.*, 1993, pp. 256–262.
- [25] W. R. Provancher, M. K. Cutkosky, K. J. Kuchenbecker, and G. Niemeyer, "Contact location display for haptic perception of curvature and object motion," *Int. J. Robot. Res.*, vol. 24, no. 9, pp. 1–11, 2005.
- [26] H. Dostmohamed and V. Hayward, "Contact location trajectory on the fingertip as a sufficient requisite for illusory perception of haptic shape and effect of multiple contacts," *Multi-Point Interaction with Real and Virtual Objects*. (Springer Tracts in Advanced Robotics vol. 18), D. Prattichizzo and K. Salisbury, Eds. New York: Springer-Verlag, 2005, pp. 189–198.
- [27] M. Solazzi, A. Frisoli, F. Salsedo, and M. Bergamasco, "A fingertip haptic display for improving local perception of shape cues," in *Proc. Second Joint Eurohaptics Conf. and Symp. on Haptic Interfaces for Virtual Environment and Teleoperator Systems*, 2007, pp. 409–414.

- [28] Y. Yokokohji, N. Nuramori, Y. Sato, and T. Yoshikawa, "Designing an encountered-type haptic display for multiple fingertip contacts based on the observation of human grasping behaviors," *Int. J. Robot. Res.*, vol. 24, no. 9, pp. 717–729, 2005.
- [29] J. Bliss, M. Katcher, C. Rogers, and R. Shepard, "Optical-to-tactile image conversion for the blind," *IEEE Trans. Man Mach. Syst.*, vol. 11, no. 1, pp. 58–65, 1970.
- [30] J. Pasquero, "Survey on communication through touch" Center for Intelligent Machines, McGill Univ., QC, Canada, Tech. Rep. TR-CIM 06.04, 2006.
- [31] J. Luk, J. Pasquero, S. Little, K. MacLean, V. Levesque, and V. Hayward, "A role for haptics in mobile interaction: Initial design using a handheld tactile display prototype," in *Proc. SIGCHI Conf. Human Factors in Computing Systems*, 2006, pp. 171–180.
- [32] R. H. Gault, "Recent developments in vibro-tactile research," *J. Franklin Inst.*, vol. 221, pp. 703–719, 1936.
- [33] R. T. Verrillo, "Effect of contactor area on the vibrotactile threshold," *J. Acoust. Soc. Am.*, vol. 35, no. 12, pp. 1962–1966, 1963.
- [34] C. Lenay, S. Canu, and P. Villon, "Technology and perception: The contribution of sensory substitution systems," in *Proc. Second Int. Conf. Cognitive Technology*, 1997, pp. 44–53.
- [35] J. T. Dennerlein, P. A. Millman, and R. D. Howe, "Vibrotactile feedback for industrial telemanipulators," in *Proc. Sixth Symp. Haptic Interfaces for Virtual Environment and Teleoperator Systems*, 1997, vol. 61, pp. 189–195.
- [36] E. Gunther and O'Modhrain, "Cutaneous grooves: Composing for the sense of touch," *J. New Music Res.*, vol. 32, no. 4, pp. 369–381, 2003.
- [37] J. B. van Erp and H. A. H. van Veen, "Touch down: The effect of artificial touch cues on orientation in microgravity," *Neurosci. Lett.*, vol. 404, pp. 78–82, 2006.
- [38] D. A. Kontarinis and R. D. Howe, "Tactile display of vibratory information in teleoperation and virtual environments," *Presence Teleoperators Virtual Environ.*, vol. 4, no. 4, pp. 387–402, 1995.
- [39] H.-Y. Yao, "Touch magnifying instrument for minimally invasive surgery," Master's thesis, Dept. Elect. Comput. Eng. McGill Univ., QC, Canada, 2004.
- [40] M. Fukumoto and T. Sugimura, "Active click: Tactile feedback for touch panels," in *CHI '01: Extended Abstracts on Human Factors in Computing Systems*. New York: NY: ACM, 2001, pp. 121–122.
- [41] I. Poupyrev, S. Maruyama, and J. Rekimoto, "Ambient touch: Designing tactile interfaces for handheld devices," in *Proc. 15th Annu. ACM Symp. User Interface Software and Technology*, New York, NY: ACM, 2002, pp. 51–60.
- [42] J. Linjama, J. Hakkila, and S. Ronkainen, "Hands on haptics: Exploring non-visual visualisation using the sense of touch," in *CHI 2005 Workshop on Hands on Haptics: Exploring Non-Visual Visualisation Using the Sense of Touch*, 2005.
- [43] J. Williamson, R. Murray-Smith, and S. Hughes, "Shoogle: Excitatory multimodal interaction on mobile devices," in *Proc. SIGCHI Conf. Human Factors in Computing Systems*, 2007, pp. 121–124.
- [44] H.-Y. Yao, V. Hayward, and R. E. Ellis, "A tactile enhancement instrument for minimally invasive surgery," *Comput. Aided Surg.*, vol. 10, no. 4, pp. 233–239, 2005.
- [45] J. Rován and V. Hayward, "Typology of tactile sounds and their synthesis in gesture-driven computer music performance," in *Trends in Gestural Control of Music*, M. Wanderley and M. Battier, Eds. Paris: IRCAM, 2000, pp. 297–320.
- [46] P. R. Cook, *Real Sound Synthesis for Interactive Applications*. A. K. Peters, 2002.
- [47] D. DiFilippo and D. K. Pai, "Contact interaction with integrated audio and haptics," in *Proc. Int. Conf. Auditory Display*, 2000, .
- [48] A. Crossan, J. Williamson, and R. Murray-Smith, "Haptic granular synthesis: Targeting, visualisation and texturing," in *Proc. Int. Symp. Non-Visual and Multimodal Visualization*, Piscataway, NJ, IEEE, 2004, pp. 527–532.
- [49] D. M. Howard and S. Rimell, "Real-time gesture-controlled physical modelling music synthesis with tactile feedback," *EURASIP J. Appl. Signal Process.*, vol. 7, pp. 1001–1006, 2004.
- [50] H.-Y. Yao and V. Hayward, "An experiment on length perception with a virtual rolling stone," in *Proc. Eurohaptics*, 2006, pp. 325–330.
- [51] D. K. Pai and P. R. Rizun, "The WHaT: A wireless haptic texture sensor," in *Proc. 11th Symp. Haptic Interfaces for Virtual Environment and Teleoperator Systems*, 2003, pp. 3–9.
- [52] H. Tan, N. Durlach, C. Reed, and W. Rabinowitz, "Information transmission with a multifinger tactual display," *Percept. Psychophys.*, vol. 61, no. 6, pp. 993–1008, 1999.
- [53] Tactaid "Tactaid" 7. [Online]. Available: <http://tactaid.com/>.
- [54] E. Hoggan and S. Brewster, "New parameters for tacton design," in *Proc. SIGCHI Conf. Human Factors in Computing Systems*, 2007, pp. 2417–2422.
- [55] F. P. Brooks, Jr., M. Ouh-Young, J. J. Batter, and P. J. Kilpatrick, "Project GROPE haptic displays for scientific visualization," in *Proc. Conf. Computer Graphics and Interactive Techniques*, 1990, pp. 177–185.
- [56] A. M. Knoll, "Man-machine tactile communication," Ph.D. thesis, Polytechnic Inst., Brooklyn, NY, 1971.
- [57] C. Cadoz, A. Luciani, and J. Florens, "Responsive input devices and sound synthesis by simulation of instrumental mechanisms: The CORDIS system," *Comput. Music J.*, vol. 8, no. 3, pp. 60–73, 1984.
- [58] M. J. Rosen and B. D. Adelstein, "Design of a two degree-of-freedom manipulandum for tremor research," in *Proc. IEEE Frontiers of Engineering and Computing in Health Care*, 1984, pp. 47–51.
- [59] H. Iwata, "Artificial reality with force-feedback: Development of desktop virtual space with compact master manipulator," *ACM SIGGRAPH Comput. Graph.*, vol. 24, no. 4, pp. 165–170, 1990.
- [60] V. Hayward and O. R. Astley, "Performance measures for haptic interfaces," *Robotics Research: The 7th International Symposium*, G. Giral and G. Hirzinger, Eds. Berlin: Springer-Verlag, 1996, pp. 195–207.
- [61] A. Z. Hajian and R. D. Howe, "Identification of the mechanical impedance at the human finger tip," *J. Biomech. Eng.*, vol. 119, no. 1, pp. 109–114, 1997.
- [62] S. A. Wall and W. Harwin, "A high bandwidth interface for haptic human computer interaction," *Mechatronics*, vol. 11, no. 4, pp. 371–387, 2001.
- [63] S. Dubowsky and F. Freudenstein, "Dynamic analysis of mechanical systems with clearances," *Trans. Am. Soc. Mech. Eng. B*, vol. 93, pp. 305–316, 1971.
- [64] A. Janot, C. Bidard, F. Gosselin, M. Gautier, D. Keller, and Y. Perrot, "Modeling and identification of a 3 dof haptic interface," in *Proc. IEEE Int. Conf. Robotics and Automation*, 2007, pp. 4949–4955.
- [65] M. D. Bryfogle, C. C. Nguyen, S. S. Antiazi, and P. C. Chiuo, "Kinematics and control of a fully parallel force-reflecting hand controller for manipulator teleoperation," *J. Robot. Syst.*, vol. 10, no. 5, pp. 745–766, 1993.
- [66] J. Vertut and A. Liegeois, "General design criteria for manipulators," *Mech. Mach. Theory*, vol. 16, no. 1, pp. 65–70, 1981.
- [67] B. D. Adelstein and M. J. Rosen, "Design and implementation of a force reflecting manipulandum for manual control research," in *Proc. ASME Dynamic Systems and Control Division*, 1992, vol. 42, pp. 1–12.
- [68] F. Barbagli and J. K. Salisbury, "The effect of sensor/actuator asymmetries in haptic interfaces," in *Proc. 11th Symp. Haptic Interfaces for Virtual Environment and Teleoperator Systems*, 2003, pp. 140–147.
- [69] V. Hayward, P. Gregorio, O. Astley, S. Greenish, M. Doyon, L. Lesnard, J. McDougall, I. Sinclair, S. Boelen, X. Chen, J.-P. Demers, J. Poulin, I. Benguigui, N. Almey, B. Makuc, and X. Zhang, "Freedom-7: A high fidelity seven axis haptic device with application to surgical training," in *Experimental Robotics V (Lecture Notes in Control and Information Science*, vol. 232), A. Casals and A. T. de Almeida, Eds. New York: Springer-Verlag, 1998, pp. 445–456.
- [70] G. Campion, Q. Wang, and V. Hayward, "The Pantograph Mk-II: A haptic instrument," in *Proc. IEEE/RSJ Int. Conf. Intelligent Robots and Systems*, 2005, pp. 723–728.
- [71] A. Frisoli, G. Prisco, F. Salsedo, and M. Bergamasco, "A two degrees-of-freedom planar haptic interface with high kinematic isotropy," in *Proc. Eighth IEEE Int. Workshop on Robot and Human Interaction*, 1999, pp. 297–302.
- [72] J. L. Stocco, S. E. Salcudean, and F. Sassani, "Optimal kinematic design of a haptic pen," *IEEE/ASME Trans. Mechatron.*, vol. 6, pp. 210–220, 2001.
- [73] L. Birglen, C. Gosselin, N. Pouliot, B. Monsarrat, and T. Laliberte, "SHaDe, a new 3-dof haptic device," *IEEE Trans. Robot. Autom.*, vol. 18, no. 2, pp. 166–175, 2002.

- [74] P. Buttolo and B. Hannaford, "Pen-based force display for precision manipulation in virtual environments," in *Proc. Virtual Reality Annu. Int. Symp.*, 1995, pp. 217–224.
- [75] J. Yoon and J. Ryu, "Design, fabrication, and evaluation of a new haptic device using a parallel mechanism," *IEEE/ASME Trans. Mechatron.*, vol. 6, pp. 221–233, 2001.
- [76] K. Vlachos, E. Papadopoulos, and D. N. Mitropoulos, "Mass/inertia and joint friction minimization for a low-force five-dof haptic device," in *Proc. IEEE Int. Conf. Robotics and Automation*, 2004, vol. 1, pp. 286–291.
- [77] R. Hui, A. Ouellet, A. Wang, P. Kry, S. Williams, G. Vukovich, and W. Peruzzini, "Mechanisms for haptic feedback," in *Proc. IEEE Int. Conf. Robotics and Automation.*, 1995, vol. 2, pp. 2138–2143.
- [78] *Sensible Phantom*. [Online]. Available: <http://sensible.com/products-haptic-devices.htm>.
- [79] *MPB Technologies Freedom Devices*. [Online]. Available: http://www.mpb-technologies.ca/mpbt/haptics/hand_controllers/haptics_index.html.
- [80] *Haption Virtuoso*. [Online]. Available: <http://haption.com/index.php?lang=eng&p=2>.
- [81] *Quanser Haptic Devices*. [Online]. Available: <http://www.quanser.com/>.
- [82] *Ergos Technologies Interfaces*. [Online]. Available: <http://acroe.imag.fr/ergos-technologies/>.
- [83] *Force Dimension Omega*. [Online]. Available: <http://www.forcedimension.com/fd/avs/home/>.
- [84] *Immersion Corporation Impulse Stick*. [Online]. Available: http://www.immersion.com/industrial/joystick/impulse_stick.php.
- [85] *Novint Falcon*. [Online]. Available: http://home.novint.com/products/novint_falcon.php.
- [86] M. L. Agronin, "The design of a nine-string six degree-of-freedom force-feedback joystick for telemanipulation," in *Proc. NASA Workshop Space Telerobotics*, Pasadena, CA, 1987, pp. 341–348.
- [87] M. Ishii and M. Sato, "A 3D spatial interface device using tensed strings," *Presence Teleoperators Virtual Environ.*, vol. 3, no. 1, pp. 81–86, 1994.
- [88] C. Melchiorri and G. Vassura, "Development and application of wire-actuated haptic interfaces," *J. Robot. Syst.*, vol. 18, no. 12, pp. 755–768, 2001.
- [89] N. G. Ullrich, G. Di Lieto, F. Salsedo, and M. Bergamasco, "Design and optimization of a purely rotational 3-d of haptic device," in *Proc. 10th IEEE Int. Workshop Robot and Human Interactive Communication*, 2001, pp. 100–105.
- [90] J. Murayama, L. Bougrila, Y. Luo, K. Akahane, S. Hasegawa, B. Hirsbrunner, and M. Sato, "SPIDAR G & G: A two-handed haptic interface for bimanual VR interaction," in *Proc. EuroHaptics*, 2004, pp. 138–146.
- [91] C. J. Hassler, "The effects of displacement quantization and zero-order hold on the limit cycle behavior of haptic knobs," Ph.D. thesis, Mech. Eng., Stanford University, Stanford, CA, Dec. 2001.
- [92] V. Hayward, "Toward a seven axis haptic interface," in *Proc. IEEE/R SJ Int. Conf. Intelligent Robots and Systems*, 1995, vol. 3, pp. 133–139.
- [93] C. B. Zilles and J. K. Salisbury, "A constraint-based god object method for haptic display," in *Proc. IEEE/R SJ Int. Conf. Intelligent Robots and Systems*, 1995, vol. 3, pp. 146–151.
- [94] S. E. Salcudean and T. D. Vlaar, "On the emulation of stiff walls and static friction with a magnetically levitated input output device," *J. Dyn. Syst.*, vol. 119, no. 1, pp. 127–132, 1997.
- [95] K. J. Salisbury, D. Brock, T. Massie, N. Swarup, and C. Zilles, "Haptic rendering: Programming touch interaction with virtual objects," in *Proc. Symp. Interactive 3D Graphics*, New York, NY: ACM, 1995, pp. 123–130.
- [96] D. Constantinescu, S. E. Salcudean, and E. A. Croft, "Haptic rendering of rigid contacts using impulsive and penalty forces," *IEEE Trans. Robot.*, vol. 21, pp. 309–323, 2005.
- [97] D. L. James and D. K. Pai, "A unified treatment of elastostatic and rigid contact simulation for real time haptics," *Haptics-E*, vol. 2, no. 1, 2001.
- [98] M. Mahvash and V. Hayward, "High fidelity haptic synthesis of contact with deformable bodies," *IEEE Comput. Graph. Appl.*, vol. 24, no. 2, pp. 48–55, 2004.
- [99] C. Duriez, F. Dubois, A. Kheddar, and C. Andriot, "Realistic haptic rendering of interacting deformable objects in virtual environments," *IEEE Trans. Visual. Comput. Graph.*, vol. 12, pp. 36–47, 2006.
- [100] V. Hayward and B. Armstrong, "A new computational model of friction applied to haptic rendering," in *Experimental Robotics VI*. (Lecture Notes in Control and Information Sciences vol. 250), P. Corke and J. Trevelyan, Eds. New York: Springer-Verlag, 2000, pp. 403–412.
- [101] R. Kikuuwe, N. Takesue, A. Sano, H. Mochiyama, and H. Fujimoto, "Admittance and impedance representations of friction based on implicit euler integration," *IEEE Trans. Robot.*, vol. 22, pp. 1176–1188, 2006.
- [102] J. K. Salisbury, F. Conti, and F. Barbagli, "Haptic rendering: Introductory concepts," *IEEE Comput. Graph. Appl.*, vol. 24, no. 2, pp. 24–32, 2004.
- [103] M. A. Otaduy and M. C. Lin, "Introduction to haptic rendering," *ACM SIGGRAPH 2005 Courses*, M. A. Otaduy and M. C. Lin, Eds. New York, NY: ACM, 2005, pp. A3–A33.
- [104] T. Yoshikawa, Y. Yokokohji, T. Matsumoto, and X.-Z. Zheng, "Display of feel for the manipulation of dynamic virtual objects," *Trans. ASME J. Dyn. Syst. Meas. Control*, vol. 117, no. 4, pp. 554–558, 1995.
- [105] R. B. Gillespie, "Kane's equations for haptic display of multibody systems," *Haptics-E*, vol. 3, no. 2, 2003.
- [106] D. Ruspini and O. Khatib, "A framework for multi-contact multi-body dynamic simulation and haptic display," in *Proc. IEEE/R SJ Int. Conf. Intelligent Robots and Systems*, 2000, pp. 1322–1327.
- [107] Q. Luo and J. Xiao, "Physically accurate haptic rendering with dynamic effects," *IEEE Comput. Graph. Appl.*, vol. 24, no. 6, pp. 60–69, 2004.
- [108] W. Baxter and M. C. Lin, "Haptic interaction with fluid media," in *Proc. Graphics Interface*, 2004, pp. 81–88.
- [109] A. H. Gosline and S. E. Salcudean, "Haptic simulation of linear elastic media with fluid inclusions," *Haptics-E*, vol. 3, 2005.
- [110] M. Mahvash and V. Hayward, "Haptic rendering of cutting: A fracture mechanics approach," *Haptics-E*, vol. 2, no. 3, p. 3, 2001.
- [111] M. Mahvash, "A novel approach for modeling separation forces between deformable bodies," *IEEE Trans. Inf. Technol. Biomed.*, vol. 10, no. 3, pp. 618–626, 2006.
- [112] M. Minsky, O. Ming, O. Steele, F. Brooks, Jr., and M. Behensky, "Feeling and seeing: Issues in force display," in *Proc. Conf. Computer Graphics and Interactive Techniques*, 1990, vol. 24, pp. 235–241.
- [113] E. Bonneton, "Pantograph project: Implementation of a virtual wall" Center for Intelligent Machines, McGill Univ., QC, Canada, Tech. Rep. 1994.
- [114] J. J. Gil, E. Sanchez, T. Hulin, C. Preusche, and G. Hirzinger, "Stability boundary for haptic rendering: Influence of damping and delay," in *Proc. IEEE Int. Conf. Robotics and Automation*, 2007, pp. 124–129.
- [115] J. E. Colgate and G. Schenkel, "Passivity of a class of sampled-data systems: Application to haptic interfaces," in *Proc. American Control Conf.*, 1994, pp. 3236–3240.
- [116] L. Love and W. Book, "Contact stability analysis of virtual walls," in *Proc. ASME Dynamic Systems and Control Division*, 1995, vol. 57, pp. 689–694.
- [117] B. Gillespie and M. Cutkosky, "Stable user-specific rendering of the virtual wall," in *Proc. ASME Dynamic Systems and Control Division*, 1996, vol. 58, pp. 397–406.
- [118] R. Ellis, N. Sarkar, and M. A. Jenkins, "Numerical methods for the force reflection of contact," *ASME Trans. Dyn. Syst. Model. Control*, vol. 119, no. 4, pp. 768–774, 1997.
- [119] B. E. Miller, J. E. Colgate, and R. A. Freeman, "Guaranteed stability of haptic systems with nonlinear virtual environments," *IEEE Trans. Robot. Autom.*, vol. 16, pp. 712–719, 2000.
- [120] B. Hannaford and J. H. Ryu, "Time-domain passivity control of haptic interfaces," *IEEE Trans. Robot. Autom.*, vol. 18, pp. 1–10, 2002.
- [121] J. J. Abbott and A. M. Okamura, "Effects of position quantization and sampling rate on virtual wall passivity," *IEEE Trans. Robot.*, vol. 21, pp. 952–964, 2005.
- [122] R. J. Adams and B. Hannaford, "Stable haptic interaction with virtual environments," *IEEE Trans. Robot. Autom.*, vol. 15, pp. 465–474, 1999.
- [123] N. Diolaiti, G. Niemeyer, F. Barbagli, and J. K. Salisbury, "Stability of haptic rendering: Discretization, quantization, time delay, and coulomb effects," *IEEE Trans. Robot.*, vol. 22, no. 2, pp. 256–268, 2006.
- [124] S. Stramigioli, C. Secchi, A. J. vander Schaft, and C. Fantuzzi, "Sampled data systems passivity and discrete port-hamiltonian systems," *IEEE Trans. Robot.*, vol. 21, pp. 574–587, 2005.
- [125] J. E. Colgate and J. M. Brown, "Factors affecting the Z-width of a haptic display," in *Proc. IEEE Int. Conf. Robotics and Automation*, 1994, pp. 3205–3210.
- [126] O. R. Astley and V. Hayward, "Multirate haptic simulation achieved by coupling finite element meshes through Norton equivalents," in *Proc. IEEE Int. Conf. Robotics and Automation*, 1998, vol. 2, pp. 989–994.

- [127] K. E. MacLean and S. S. Snibbe, "An architecture for haptic control of media," in *Proc. Symp. Haptic Interfaces for Virtual Environment and Teleoperator Systems*, 1999, pp. 219–228.
- [128] S. Cotin, H. Delingette, and N. Ayache, "Deformations of soft tissues for surgery simulation," *IEEE Trans. Visual. Comput. Graph.*, vol. 5, pp. 62–73, 1999.
- [129] M. C. Cavusoglu and F. Tendick, "Multirate simulation for high fidelity haptic interaction with deformable objects in virtual environments," in *Proc. IEEE Int. Conf. Robotics and Automation*, 2000, vol. 3. pp. 2458–2465.
- [130] F. Mazzella, K. Montgomery, and J.-C. Latombe, "The forcegrid: A buffer structure for haptic interaction with virtual elastic objects," in *Proc. IEEE Int. Conf. Robotics and Automation*, 2002, vol. 1. pp. 939–946.
- [131] M. Mahvash and V. Hayward, "High fidelity passive force reflecting virtual environments," *IEEE Trans. Robot.*, vol. 21, pp. 38–46, 2005.
- [132] F. Barbagli, D. Prattichizzo, and J. K. Salisbury, "A multirate approach to haptic interaction with deformable objects single and multipoint contacts," *Int. J. Robot. Res.*, vol. 24, no. 9, pp. 703–715, 2005.
- [133] M. R. Sirospour, S. P. DiMaio, S. E. Salcudean, P. Abolmaesumi, and C. Jones, "Haptic interface control-design issues and experiments with a planar device," in *Proc. IEEE Int. Conf. Robotics and Automation*, 2000, vol. 1. pp. 789–794.
- [134] F. Janabi-Sharifi, V. Hayward, and C.-S. J. Chen, "Discrete-time adaptive windowing for velocity estimation," *IEEE Trans. Control Syst. Technol.*, vol. 8, pp. 1003–1009, 2000.
- [135] G. Liu, "On velocity estimation using position measurements," in *Proc. American Control Conf.*, 2002, vol. 2. pp. 1115–1120.
- [136] J. H. Ryu, C. Preusche, B. Hannaford, and G. Hirzinger, "Time domain passivity control with reference energy following," *IEEE Trans. Control Syst. Technol.*, vol. 13, pp. 737–742, 2005.
- [137] A. H. Gosline and V. Hayward, "Time-domain passivity control of haptic interfaces with tunable damping hardware," in *Proc. Second Joint Eurohaptics Conf. and Symp. Haptic Interfaces for Virtual Environment and Teleoperator Systems*, 2007, pp. 164–169.
- [138] J. S. Mehling, J. E. Colgate, and M. A. Peshkin, "Increasing the impedance range of a haptic display by adding electrical damping," in *Proc. First Joint Eurohaptics Conf. and Symp. Haptic Interfaces for Virtual Environment and Teleoperator Systems*, 2005, pp. 257–262.
- [139] J. An and D. S. Kwon, "Stability and performance of haptic interfaces with active/passive actuators theory and experiments," *Int. J. Robot. Res.*, vol. 25, no. 11, pp. 1121–1136, 2006.
- [140] J. D. Hwan, M. D. Williams, and G. Niemeyer, "Toward event-based haptics: Rendering contact using open-loop force pulses," in *Proc. Int. Symp. Haptic Interfaces for Virtual Environment and Teleoperator Systems*, 2004, pp. 24–31.
- [141] A. M. Okamura, C. Richard, and M. R. Cutkosky, "Feeling is believing: Using a force-feedback joystick to teach dynamic systems," *J. Eng. Educ.*, vol. 91, no. 3, pp. 345–349, 2002.
- [142] M. Shaver and K. E. MacLean, "The twiddler: A haptic teaching tool: Low-cost communication and mechanical design," Dept. Comput. Sci. Univ. British Columbia, Vancouver, Canada, Tech. Rep. TR-2005-09, 2004.
- [143] W. Verplank, "Haptic music exercises," in *Proc. 2005 Conf. New Interfaces for Musical Expression*, 2005, pp. 256–257.
- [144] A. M. Okamura and D. Brzozowski, *Haptic displays for teaching dynamic systems*. [Online]. Available: <http://www.haptics.me.jhu.edu/research/paddle/paddle.html>.
- [145] *Chai3d, the open source haptics project*. [Online]. Available: <http://www.chai3d.org/>.
- [146] *Haptik library, the open source library for haptics*. [Online]. Available: <http://www.haptiklibrary.org/>.
- [147] G. Pava and K. E. MacLean, "Real time platform middleware for transparent prototyping of haptic applications," in *Proc. 12th Symp. Haptic Interfaces for Virtual Environment and Teleoperator Systems*, 2004, pp. 383–391.
- [148] H. Dostmohamed and V. Hayward, "Trajectory of contact region on the fingerpad gives the illusion of haptic shape," *Exp. Brain Res.*, vol. 164, no. 3, pp. 387–394, 2005.
- [149] B. Buxton, *A directory of sources for input technologies*. [Online]. Available: <http://www.billbuxton.com/inputsources.html>.
- [150] J. Biggs and M. A. Srinivasan, "Haptic interfaces," *Handbook of Virtual Environments*, K. Stanney, Ed. Mahwah, NJ: Lawrence Erlbaum, 2002, pp. 93–116.
- [151] V. Hayward, O. R. Astley, M. Cruz-Hernandez, D. Grant, and G. Robles-De-La-Torre, "Haptic interfaces and devices," *Sens. Rev.*, vol. 24, no. 1, pp. 16–29, 2004.
- [152] L. Jones and N. Sarter, "Tactile displays: Guidance for their design and application," *Hum. Factors J. Hum. Factors Ergon. Soc.*, to be published.
- [153] K. E. MacLean, "Designing with haptic feedback," in *Proc. IEEE Int. Conf. Robotics and Automation*, 2002, pp. 783–788.
- [154] J. B. Morrell and J. K. Salisbury, "Performance measurements for robotic actuators," in *Proc. ASME Dynamic Syst. and Control Division*, 1996, vol. 58. pp. 531–537.
- [155] R. E. Ellis, O. M. Ismaeil, and M. G. Lipsett, "Design and evaluation of a high-performance haptic interface," *Robotica*, vol. 14, pp. 321–327, 1996.
- [156] M. Moreyra and B. Hannaford, "A practical measure of dynamic response of haptic devices," in *Proc. IEEE Int. Conf. Robotics and Automation*, 1998, pp. 369–374.
- [157] A. Frisoli and M. Bergamasco, "Experimental identification and evaluation of performance of a 2 DOF haptic display," in *Proc. IEEE Int. Conf. Robotics and Automation*, 2003, vol. 3. pp. 3260–3265.
- [158] I. M. Stuart, "Capstan equation for strings with rigidity," *Br. J. Appl. Phys.*, vol. 12, pp. 559–562, 1961.

Vincent Hayward received the Ing. Ecole from Centrale de Nantes in 1978. He received his Ph.D. in computer science from the University of Paris in 1981. He was Chargé de recherches at CNRS, France, from 1983 to 1986. Currently, he is professor of electrical and computer engineering at McGill University, Quebec, Canada. Hayward is interested in haptic interfaces design as well as applications, perception, and robotics. He is leading the Haptics Laboratory at McGill University. He is the recipient of the NASA Space Act Tech Brief Award (1991) and the E. (Ben) & Mary Hochhausen Award for Research in Adaptive Technology for Blind and Visually Impaired Persons (2002). He has several publications in the area of robotics and haptic interfaces, has served on several editorial boards, and has participated in the creation of spin off companies. He is a Fellow of the IEEE.

Karon E. MacLean received the B.S. degree in biological sciences and mechanical engineering from the Stanford University, California, in 1986 and the M.S. degree in mechanical engineering from MIT in 1988. She served as an engineer at the Center for Engineering Design, University of Utah, from 1988 to 1990. She received her Ph.D. in mechanical engineering from MIT in 1996. She was a member of the research staff of Interval Research Corp. from 1996 to 2000. She is now an associate professor at the Computer Science Department of the University of British Columbia, where she leads the Sensory Perception and Interaction Research Group (SPIN Lab). MacLean is concerned with haptic interaction design: how to use haptic technology to solve peoples' problems in usable ways, in the real world. She has received the Peter Wall Early Career Scholar (2001) and the Izzak Walton Killam Memorial Faculty Research Fellowship (2007). She is a founding member of several editorial and advisory boards.

Address for Correspondence: Vincent Hayward, Centre for Intelligent Machines, McGill University, 3480 University St., Montreal, Quebec, Canada H3A 2A7. E-mail: hayward@cim.mcgill.ca.