

Newton's Observations of Diffracted Rays

G. Pelosi¹, S. Selleri¹, and P. Ya. Ufimtsev²

¹Electromagnetics and Microwave Engineering Laboratory
Electronic Engineering Department
University of Florence
Via C. Lombroso 6/17
50134, Florence
Italy
Tel: 39 55 4796 767
Fax: 39 55 4796 759
E-mail: pelosi@ingfi1.ing.unifi.it

²Electrical Engineering Department
University of California, Los Angeles
56-125B Engineering IV Building
420 Westwood Plaza
Los Angeles, CA 90095-1594
USA
Tel: (562) 948-8303

Keywords: History; optical diffraction

1. Introduction

The concept of a Diffracted Ray is a very popular and efficient tool for the solution of a variety of practical problems related to high-frequency scattering and radiation. The model has become so well established in these last few decades that, nowadays, we talk of diffracted rays as being real physical objects.

The history of Diffracted Rays is usually considered to be less than a century long. As a matter of fact, the very term *Diffracted Ray* was first introduced by Kalashnikov, in 1911, who also suggested an objective proof of their existence by recording them on photographic plates [1]. This result was appreciated by Sommerfeld ([2], p. 845). Later on, the ray structure of diffracted fields was established theoretically, in 1924, by Rubinowicz [3], and later by many other authors. Finally, the concept of diffracted rays was formulated, in the most general form, by Keller in the '60s, and from this formulation his famous GTD was born [4-5].

Despite this, a careful study of experiments and observations made by Newton (Figure 1) and described in his *Optiks* (Figure 2) [5] shows that diffracted rays had been observed long before 1911, actually, nearly 300 years ago. To show this is the goal of the present paper. *Optiks Book III*, part I, also comprehends diffraction, as can be understood by the foreword:

Observations concerning the Inflexions of the Rays of Light, and the Colours made thereby.

Grimaldo has inform'd us, that if a beam of the Sun's Light be let into a dark Room through a very small hole, the Shadows of things in this Light will be larger than they ought to be if the Rays went on by the Bodies in straight Lines....

Of the various Newton's observations that follow, two have been chosen to demonstrate, by applying modern theories, that Newton was actually observing diffracted rays.

2. Diffracted rays in Newton's Observation 5

The first Observation, suitable to show how Newton was actually writing of such a thing as a diffracted ray, is Obs. 5:

Obs. 5. The Sun shining into my darken'd Chamber through a hole a quarter of an Inch broad, I placed at a distance of two or three Feet from the Hole a Sheet of Pasteboard, which was blacken'd all over on both sides, and in the middle of it had a hole about three quarters of an Inch square for the Light to pass Through. And behind the hole I fasten'd to the Paste-



Figure 1. Sir Isaac Newton.

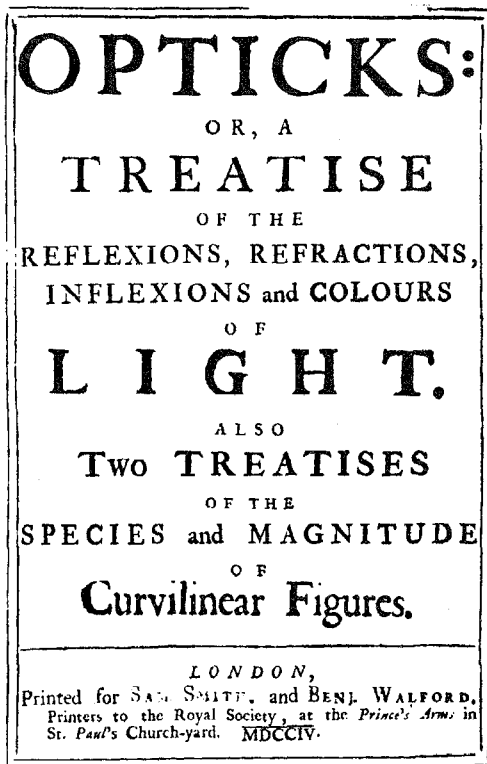

Figure 2. The title page of Newton's *Opticks*, 1704 edition.

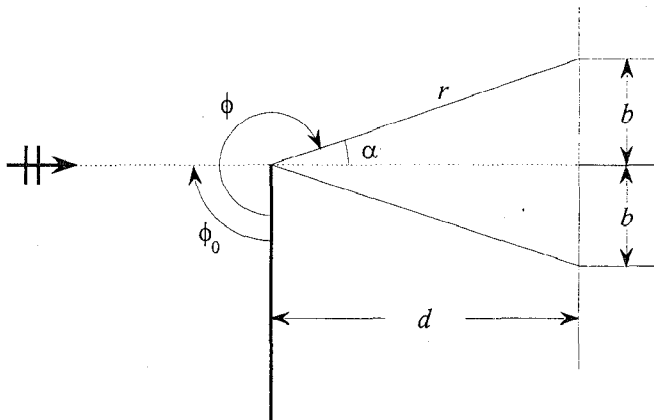

Figure 3. The geometry of the half-plane scattering problem.

board with Pitch the blade of a sharp Knife, to intercept some part of the Light which passed through the hole. The Planes of the Pasteboard and the blade of the Knife were parallel to one another, and perpendicular to the Rays. And when they were so placed that none of the Sun's Light fell on the Pasteboard, but all of it passed through the hole to the Knife, and there part of it fell upon the blade of the Knife, and part of it passed by its edge; I let this part of the Light which passed by, fall on a white Paper two or three Feet beyond the Knife, and there saw two streams of faint Light into the shadow, like the Tails of Comets. But because the Sun's Direct Light by its brightness upon the Paper obscured these faint streams, so that I could scarce see them, I made a little hole in the midst of the Paper for that Light to pass through and fall on a black Cloth behind it; and then I saw the two streams plainly. The were like one another, and pretty nearly equal in length, and breadth,

and quantity of Light. Their Light at the end next the Sun's direct Light was pretty strong for the space of about a quarter of an Inch, and in all its progress from that direct Light decreased gradually till it become insensible. The whole length of either of these streams measured upon the paper at the distance of three Feet from the Knife was about six or eight Inches; so that it subtended an Angle at the edge of the Knife of about 10 or 12, or at most 14 Degrees. Yet sometimes I thought I saw it shoot three or four Degrees farther, but with a Light so very faint that I could scarce perceive it, and suspect it might (in some measure at least) arise from some other cause than the two streams did.

This is actually an observation of the well-known canonical problem of the diffraction of a plane wave perpendicularly impinging on a perfectly reflecting half-plane (Figure 3). d is the distance between the edge of the half-plane (Newton's knife edge) and the screen where the diffraction effect is observed, and b is the length of the tail of comet. According to Newton's observation,

$$d = 91.44 \text{ cm} = 3 \text{ ft}, \quad b = 15 - 20 \text{ cm} = 6 - 8 \text{ in.} \quad (1)$$

On the other hand, from the modern theory of diffraction, we know that the diffracted field arising from the scattering of a plane wave at a half-plane is determined by the Sommerfeld integral [7] as

$$u^{dif} = v(kr, \phi - \phi_0) \pm v(kr, \phi + \phi_0), \quad (2)$$

where

$$v(kr, \psi) = e^{-ikr \cos \psi} \frac{e^{-i\pi/4}}{\sqrt{\pi}} \int_{\infty \cos(\psi/2)}^{\sqrt{2kr} \cos(\psi/2)} e^{ix^2} dx, \quad (3)$$

and the signs + or - in Equation (2) depend on the incident polarization. Since the sun's light has random polarization, in our analysis, the sign will be irrelevant. What we need to estimate is where the diffracted field has a ray structure, and if this region coincides with the tail of the comet described by Newton. The diffracted field can be regarded as having a ray structure in the region where the Fresnel integral, Equation (3), reduces to its asymptotic form:

$$v(kr, \psi) \cong -\frac{1}{2 \cos \frac{\psi}{2}} \frac{e^{i\left(\frac{kr}{2} + \frac{\pi}{4}\right)}}{\sqrt{2\pi kr}}, \quad (4)$$

in which it is easy to recognize a diffracted ray. It can be shown that this ray approximation is valid in the region where one can neglect the second term in the asymptotic expansion of the Fresnel integral, Equation (2). The magnitude of this term is of the order of $1/p_{\pm}^3$, where

$$p_{\pm} = \sqrt{2kr} \left| \cos \frac{\psi}{2} \right| = \sqrt{2kr} \left| \cos \frac{\phi \pm \phi_0}{2} \right|. \quad (5)$$

Lets us estimate Equation (5) for the region observed by Newton. Figure 4 reports the value of $1/p_{\pm}^3$ versus b . This is enough, since the value $1/p_{+}^3$ is everywhere less than $1/p_{-}^3$. The two curves are relative to the two extremes of the visible spectrum, internationally set to $\lambda = 7800\text{\AA}$ (red) and $\lambda = 3800\text{\AA}$ (violet).

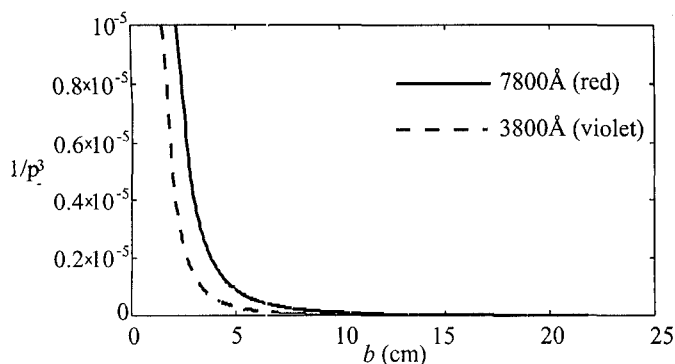

Figure 4. Values of $1/p^3$ for different values of b .

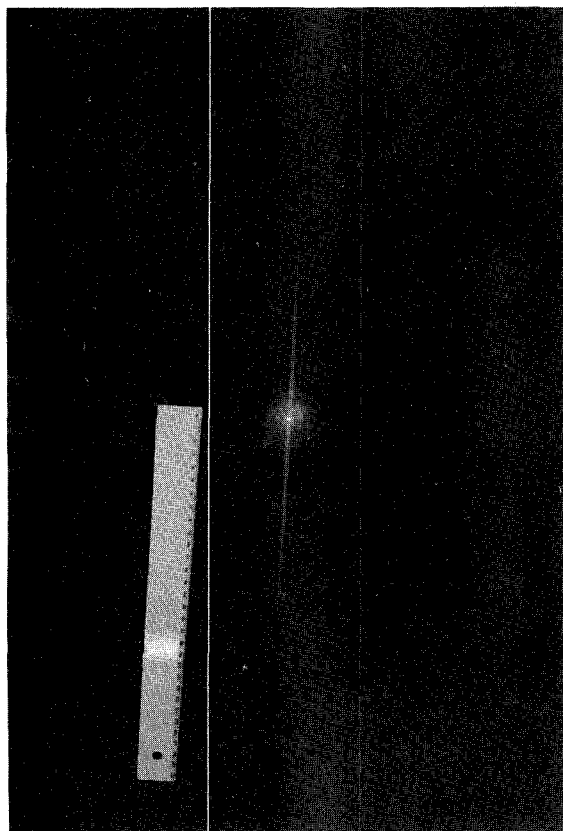

Figure 5. The diffraction pattern obtained on a white screen by illuminating a horizontal razor blade with a laser beam.

Other values of wavelength in the visible spectrum produce curves in between these two.

From Figure 4, it follows that the value of $1/p^3$ is less than 10^{-4} if $b > 2$ cm. Therefore, the diffracted field has a ray structure everywhere in the region where $b > 2$ cm, which corresponds to $\theta \geq 1^\circ 15' 11''$. This means that Newton was really observing diffracted rays. He confirmed this in the paragraph of Obs. 5 immediately following the one cited before:

For placing my Eye in that Light beyond the end of that stream which was behind the Knife, and looking towards the Knife, I could see a line of Light upon its edge, and that not only when my Eye was in the line of the Streams, but also when it was without that line

either towards the point of the knife or towards the handle.

It is evident that Newton himself observed how these *streams of light* appear to be generated by a *line of light* at the edge of the wedge, exactly as modern theories describe diffracted rays as propagating from the edge of the wedge so as to satisfy Fermat's principle.

Figure 5 shows a photograph taken into a dark chamber where this observation was reproduced. The experiment was carried out using a red He-Ne 18 mW laser (wavelength $\lambda = 6328\text{\AA}$) and a razor blade. The laser beam, intercepted by the horizontal razor blade, showed the diffraction pattern in Figure 5 on a white screen. The distance between the blade and the screen was set to 100 cm; the length of the lines illuminated by the diffracted rays (Newton's *tail of the comet*) was $b = 25$ cm. This leads to an angle $\theta = 14^\circ$, which is the maximum observed by Newton.

3. Diffracted rays in Newton's Observation 10

Another interesting observation, which can be explained with modern theories of diffraction, is number 10. This observation uses a configuration described in the preceding Obs. 8:

Obs. 8. I caused the edges of two Knives to be ground truly strait, and pricking their points into a Board so that their edges might look towards one another, and meeting near their points contain a rectilinear Angle, I fasten'd their Handles together with Pitch to make this Angle invariable. The distance of the edges of the Knives from one another at the distance of four Inches from the angular Point, where the edges of the Knives met, was the eight part of an Inch; and therefore the Angle contain'd by the edges was about one Degree 54'.

This configuration can be theoretically modeled by two perfectly conducting coplanar half-planes whose edges form an angle α , as in Figure 6.

Angle α is said by Newton to be about $1^\circ 54'$, but by his numerical data, a value of $1^\circ 47' 26''$ can be computed. Furthermore, in the following Obs. 10, the configuration is said to be the same, but from Newton's figure, here reported in Figure 7, an $\alpha = 4^\circ 44'$ can be calculated. Observation 10 then reports the presence of dark lines in the lightened region of the screen, as reported in Figure 7, directly reproduced from Newton work.

This configuration may be studied by writing the total field as a summation of a Geometrical Optics field and the two diffracted-field contributions from the two edges, as in Equation (2).

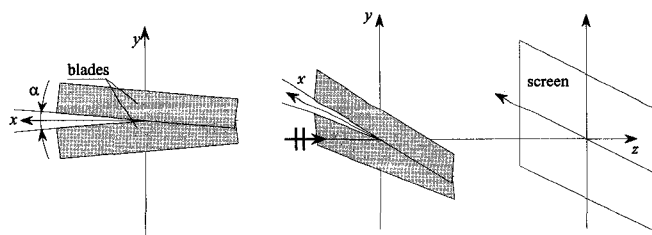

Figure 6. The configuration of Obs. 8 and 10.

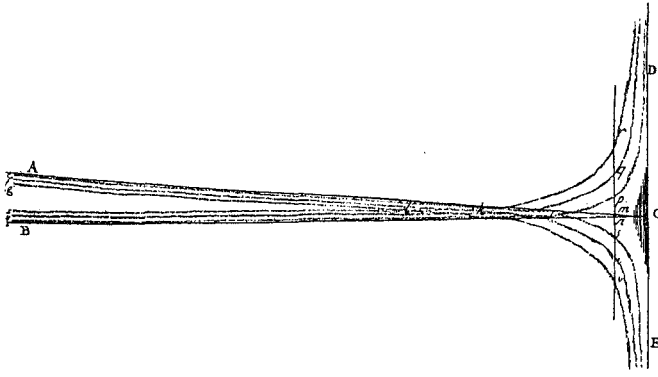

Figure 7. Newton's drawing of interference fringes in Obs. 10.

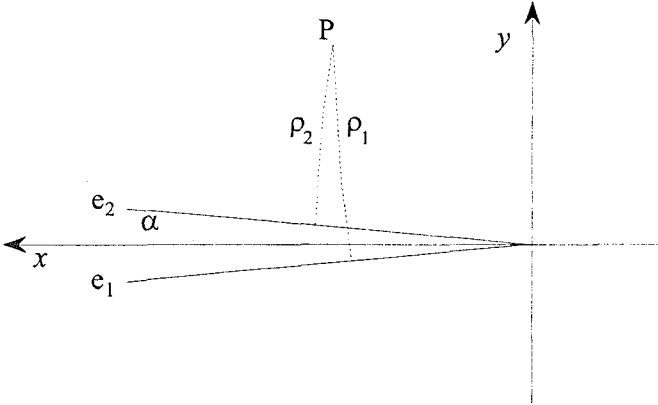

Figure 8. The projection of the diffracted rays onto a $z = \text{const}$ plane.

According to GTD, the diffracted field at any point in the ray region consists of two diffracted rays coming from direction points at both edges (we neglect the corner ray). These rays are perpendicular to their relative scattering edge, e_1 or e_2 . The projections of these rays on the observation plane $z = \text{const}$ are the segments ρ_1 and ρ_2 , shown in Figure 8. Thus,

$$\rho_1 = \left| x \sin \frac{\alpha}{2} + y \cos \frac{\alpha}{2} \right|, \quad (6a)$$

$$\rho_2 = \left| x \sin \frac{\alpha}{2} - y \cos \frac{\alpha}{2} \right|. \quad (6b)$$

The lengths of the rays r_1 and r_2 are consequently $r_{1,2} = \sqrt{\rho_{1,2}^2 + z^2}$. Indeed, since we are investigating a zone near to the incident shadow boundary but far from the reflected shadow boundary, only the first term of Equation (2) is significant. This can be easily shown by considering that Newton observed the intensity of a randomly polarized field, an intensity that we may approximate as $I = (I^+ + I^-)/2$, with

$$I^+ = |v(kr, \phi - \phi_0) + v(kr, \phi + \phi_0)|^2 \text{ and}$$

$$I^- = |v(kr, \phi - \phi_0) - v(kr, \phi + \phi_0)|^2,$$

and thus

$$I = |v(kr, \phi - \phi_0)|^2 + |v(kr, \phi + \phi_0)|^2.$$

The first term has a magnitude comparable to $1/p_-^2$, while the second is of the order of $1/p_+^2$. Their ratio may be used to determine if the second term can be neglected. By resorting to Equation (5), this ratio is

$$\frac{|v(kr, \phi + \phi_0)|^2}{|v(kr, \phi - \phi_0)|^2} = \frac{|v_+|^2}{|v_-|^2} \approx \frac{p_-^2}{p_+^2} = \frac{\cos^2\left(\frac{\phi - \phi_0}{2}\right)}{\cos^2\left(\frac{\phi + \phi_0}{2}\right)}. \quad (7)$$

For our problem, $\phi_0 = 90^\circ$, and this ratio is actually small for observation points that lie near the direction $\phi = 270^\circ$. This can be clearly seen in Figure 9, which reports both the ratio p_-^2/p_+^2 and the ratio $|v_+|^2/|v_-|^2$. The excellent agreement between the two different plots is due to the fact that, at optical frequencies and at a distance r of the order of meters (as for the experimental setting detailed below), the term kr is very large (10^7), and the approximation is very good.

Since the diffracted field can be approximated in the neighborhood of the incident shadow boundary by the first term of Equation (2) alone, as confirmed by Figure 9, and does not depend practically on polarization, the total field behind the screen can be written as

$$u(x, y) = \begin{cases} e^{ikz} - \frac{1}{\sqrt{\pi}} e^{i\left(kz - \frac{\pi}{4}\right)} \left[\int_{q_1}^{\infty} e^{it^2} dt + \int_{q_2}^{\infty} e^{it^2} dt \right], & y_1 \leq y \leq y_2 \\ \frac{1}{\sqrt{\pi}} e^{i\left(kz - \frac{\pi}{4}\right)} \left[\int_{q_2}^{\infty} e^{it^2} dt - \int_{q_1}^{\infty} e^{it^2} dt \right], & y > y_2 \\ -\frac{1}{\sqrt{\pi}} e^{i\left(kz - \frac{\pi}{4}\right)} \left[\int_{q_2}^{\infty} e^{it^2} dt - \int_{q_1}^{\infty} e^{it^2} dt \right], & y < y_1 \end{cases} \quad (8)$$

where the quantities $y_1 = -x \tan(\alpha/2)$ and $y_2 = x \tan(\alpha/2)$ denote the boundaries of the geometrical-optics field; $r_{1,2} = \sqrt{\rho_{1,2}^2 + z^2}$ are the distances between the observation point, $P(x, y, z)$, and the

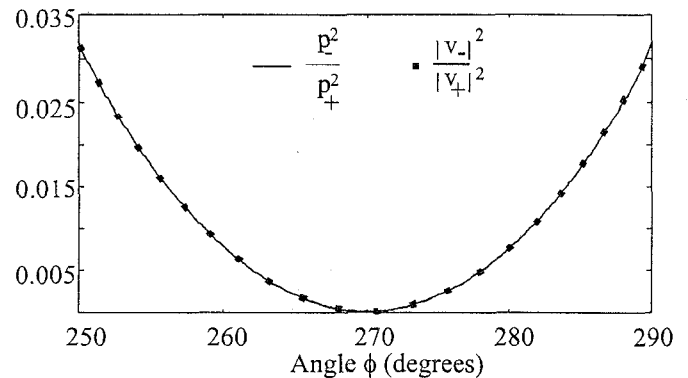

Figure 9. The ratio between of the magnitudes of the two terms $1/p_+^2$ and $1/p_-^2$ (solid line), and of the magnitude of the terms $|v_+|^2$ and $|v_-|^2$ (dots).

scattering edges, $e_{1,2}$, and $q_{1,2}$ are the equivalent of the quantity ρ_- for the same two edges, that is, $q_{1,2} = \sqrt{k(r_{1,2} - z)}$.

Besides the already cited second term in Equation (2), Equation (8) does not take into account the multiple diffraction and the effect of the tip. The lit region corresponds to the triangle ABC in Figure 7. Here, there is the presence of direct rays, which impinge normally on the screen. The shadow region is the remainder of the screen. The diffracted rays exist everywhere on the screen, in the ray region, and are everywhere perpendicular to the blades' edges.

Figure 10 shows the diffraction pattern obtained experimentally (Figure 10a), and the pattern obtained by implementing Equation (8) (Figure 10b). The geometrical configuration used is reported shortly, below, and is that for which Newton provides numerical data. As it can be noted in both cases, the hyperbola-like dark curves, observed by Newton, are obtained. To further investigate these lines, their analytical expression can be extracted from Equation (8), once it is recognized that they are curves defined by the equation $|r_1 - r_2| = q = (2n + 1)\lambda/2$.

As for Obs. 10, we may distinguish a ray region and a Fresnel region; here and in the following for $1/q_{1,2}^3 < 10^{-3}$, the field is considered to have a ray structure. For the laser's wavelength ($\lambda = 6328\text{\AA}$), this happens for points on plane xy that are more than 0.74 cm above or below the projection of the two edges, as is shown even better in Figure 11.

A truly significant validation of the fact that Diffracted Rays were responsible for the interference figures obtained by Newton

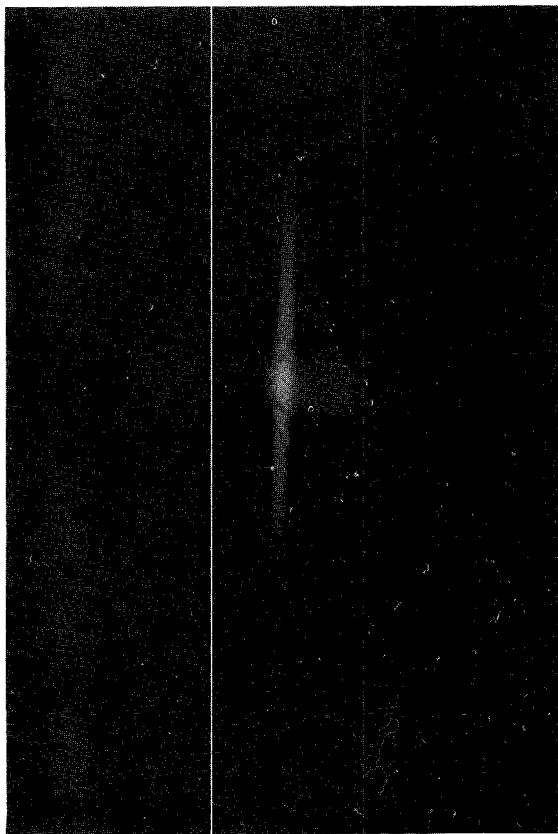

Figure 10a. Laser ray diffraction fringes, $\lambda = 6328\text{\AA}$.

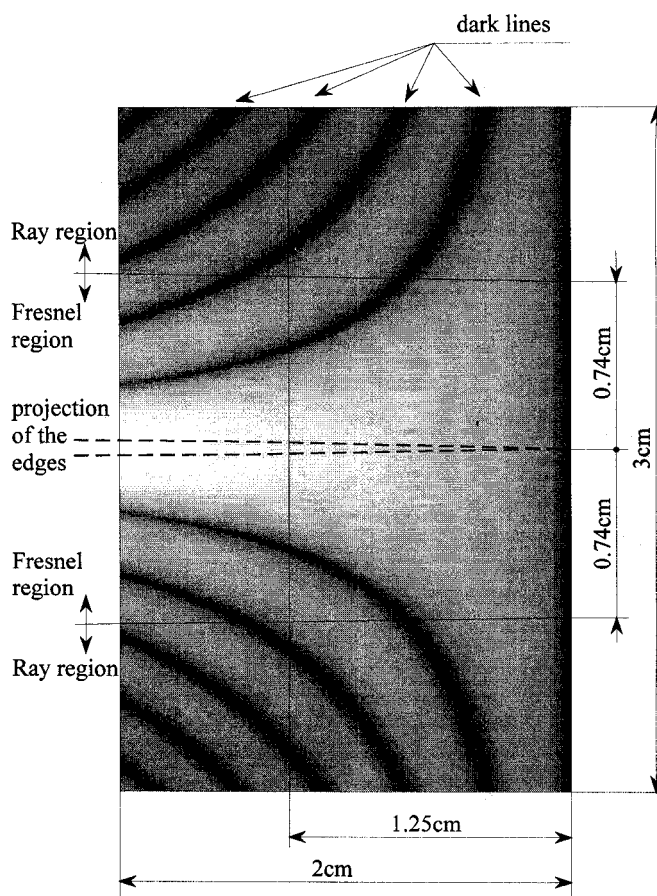

Figure 10b. A numerical field evaluation of the diffraction fringes ($\lambda = 6328\text{\AA}$). To better show the interference fringes, the field map shows the logarithm of the field magnitude. The limits of the ray region are also indicated.

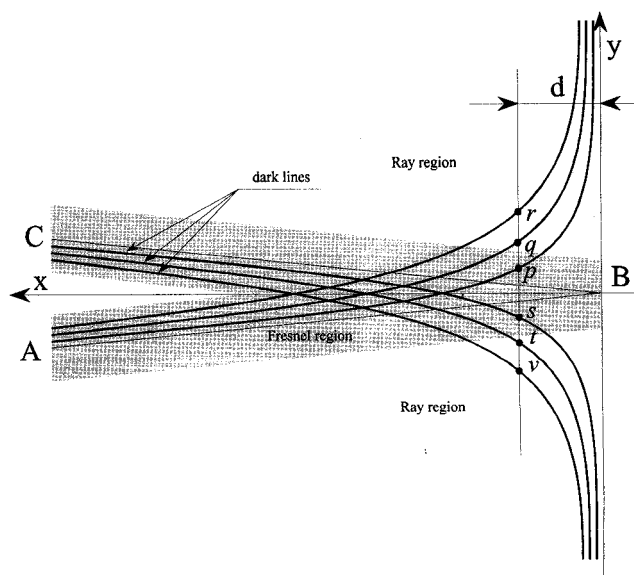

Figure 11. A schematic diagram of the interference fringes. On this duplicate of Newton's Figure (Figure 7 of the present paper), the Fresnel region is shadowed. It is evident how the hyperbola branches near the vertical asymptote are in the ray region.

can be found in the following passage of Obs. 10, which also describes the geometrical configuration, also used in this paper:

Obs. 10. ...For instance: when the Knives were distant from the hole in the Window ten Feet, and the Paper from the Knives nine Feet, and the Angle contained by the edges of the Knives to which the angle ACB is equal, was subtended by a Chord which was to the radius as 1 to 32, and the distance of the line rv from the Asymptote DE was half an Inch: I measured the lines ps, qt, rv, and found them 0'35, 0'65, 0'98 Inches respectively....

where points *A, B, C, p, q, r, s, t,* and *u* are indicated in Figure 3 of Newton's *Optiks* (Figure 7 of this paper), and, for more clarity, are reported also in Figure 11.

Thus, Newton's Observation is equivalent to measuring the distances of the intersection of the dark hyperbola with a line parallel to the *y* axis, and placed at a distance $d = 1.25 \text{ cm} = 0.5 \text{ in}$ from the vertical asymptotes (Figure 11). The other geometrical data are the distance $z = 274.32 \text{ cm} = 9 \text{ ft}$ between the blades and the screen, and the blades' angle $\alpha = 1^\circ 47' 26''$.

With this data, and by choosing a wavelength in the high-middle portion of the visible spectrum (that portion where the sun's rays bear maximum power), Equation (7) can be used to plot the field magnitude as a function of *y*. The results are shown in Figure 12, which is computed at the wavelength $\lambda = 6328 \text{ \AA}$. The distances between the corresponding minima are indicated here, and thus the distance between the hyperbola's intersection with the vertical line, measured by Newton. Since we are interested in the zones where the field has a ray structure, on the same figure are shown the zones where $1/q_{1,2}^3 < 10^{-3}$. For the case under examina-

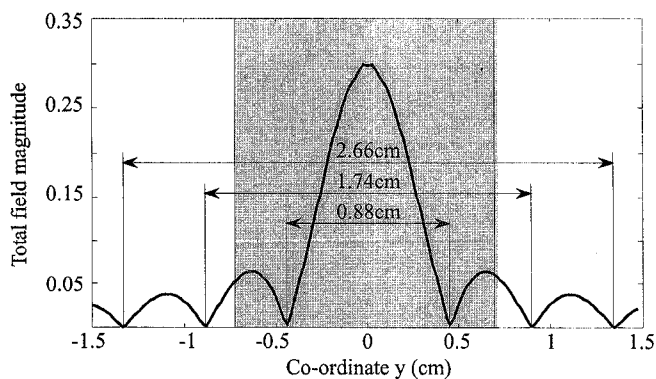

Figure 12. The field nulls along the line *rv*. The shadowed region corresponds to the Fresnel region; the regions to the right and the left are ray regions ($\lambda = 6328 \text{ \AA}$).

Table 1. The distances between corresponding minima in the numerical simulation and in Newton's observations.

	Simulation 6328Å	Simulation 6000 Å	Simulation multifrequency envelope	Newton (cm)	Newton (inches)
<i>ps</i>	0.88	0.86	0.84	0.86	0.35
<i>qt</i>	1.74	1.63	1.68	1.63	0.65
<i>rv</i>	2.66	2.45	2.60	2.45	0.98

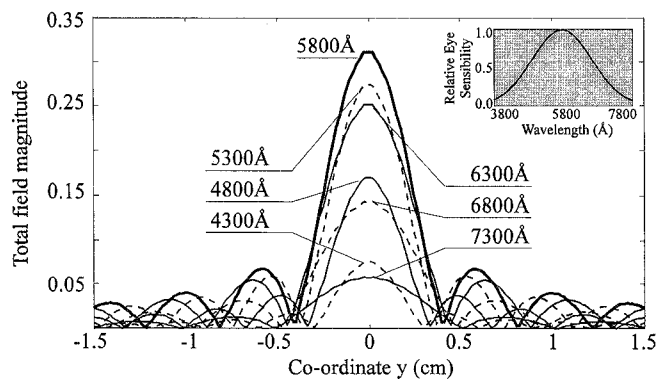

Figure 13. The field magnitude along a line *rv* at different frequencies. The fields are weighted by the human eye's response curve, shown at the top right.

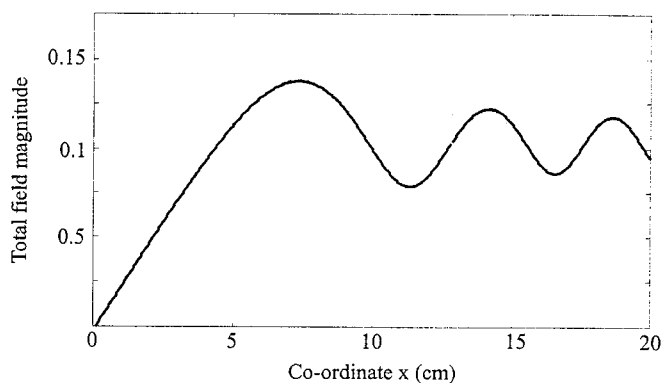

Figure 14. Field minima along the *x* axis ($\lambda = 6328 \text{ \AA}$).

tion, at $x = 1.25 \text{ cm}$, the limits of this region are $y = \pm 0.74 \text{ cm}$. These minima match well with Newton's data, as shown in Table I. Furthermore, since for $|y| > 0.74 \text{ cm}$ the field can be considered to have a ray structure, at least two of the minima observed by Newton are actually in the ray region. It must be noted that single-frequency computations, as that shown in Figure 12, lead to minima, and thus dark lines, which are much sharper than Newton's, who was observing sunlight. This can clearly be seen in Figure 13, where the field magnitude along line *rv* is computed at different frequencies, taking into account the human eye's sensitivity [8]. The envelope of these curves can provide a good approximation of what Newton really saw. A correct integral over the whole spectrum can be made only on a statistical basis, since the phases of the different frequencies are completely uncorrelated. From this figure, it is also apparent how the minima of the envelope are much less evident. This explains why Newton observed only three pairs of dark hyperbolae, while monochromatic simulation and experiments show many more.

It has thus been shown that of the three fringes observed by Newton, at the very beginning of the XVIII century, at least two pairs are actually obtainable by applying the modern theory of diffraction.

Concerning the equation governing such fringes, Newton says, by measurements, that

Obs. 10. ...and thereby know that these curve lines are Hyperbolae differing little from the Conical Hyperbola....

As a matter of fact, by assuming, as a first hypothesis, that $z \gg x$ and $z \gg y$, a Taylor expansion of the roots can be exploited, and the equation $r_1 - r_2 = q$ can be transformed into

$$xy = \frac{qz}{\sin \alpha}. \quad (9)$$

This equation represents a family of hyperbolas, with the axes $x=0$ and $y=0$ as asymptotes. This is too much of an approximation, since we know that the fringes observed by Newton intersect on the $y=0$ axis. This is also evident in Figure 14, where the field in Equation (8) is plotted for the same configuration, at $y=0$ and $x \in [0, 20]$ cm. The local minima around 11 cm, 16 cm, and 20 cm correspond to the points where dark fringes intersect. It must be noted that the whole figure here represents fields that are in the Fresnel region, and not in the ray region.

A more exact expression may be obtained by considering separately the cases $|x| \rightarrow \infty$ and $|y| \rightarrow \infty$. In the first case, the first two terms of Taylor's expansion leads to an asymptote that is $y = -q/(2 \cos \alpha/2)$, that is, a horizontal line below the x axis, while in the second case, the asymptote obtained is a vertical line $x = -q/(2 \sin \alpha/2)$.

With further investigation, and by taking into account higher-order terms, one can obtain for $y \rightarrow \infty$ the expression

$$y^2 \cong \frac{a}{x+b} = \frac{qz^2}{2 \cos^2 \frac{\alpha}{2} \left(2x \sin \frac{\alpha}{2} - q \right)}, \quad (10)$$

which is a third-order curve.

4. Conclusions

The above analysis clearly shows that the diffracted rays, discovered and developed in this century, were actually observed and described by Newton almost 300 years ago. The modern reader of Newton's *Optiks* cannot refrain from being amazed by how this genius could reveal such subtle features with such simple experiments. It turns out that this brilliant theoretician was also a brilliant experimenter, able to observe and measure diffraction fringes produced by two knives under sunlight.

We should point out, anyway, that Newton became interested in diffraction as a result of his reading of Grimaldi's communication describing his discovery of this phenomenon [9]. The publication of Grimaldi's work happened approximately 40 years prior to the first publication of Newton's experiments [6], in 1704, few studies having been carried out on diffraction in the meantime.

One can guess that some of Grimaldi's observations on diffraction can be explained by resorting to diffracted rays, too.

4. References

1. A. Kalashnikov, "The Gouy-Sommerfeld Diffraction," *Zhurnal Russkogo Fiziko-Khemicheskogo Obshchestva (Journal of the Russian Physical-Chemical Society)*, **44**, 3, Physical Section, 1911, pp. 137-144.

2. A. Sommerfeld, "Theorie der Beugung," Chapter 20 in Ph. Frank and R. Mises (eds.), *Die Differential- und integralgleichungen der Mechanik und der Physik*, Braunschweig, Germany, Vieweg & Sohn, 1935 (American publication: New York, M. S. Rosenberg, 1943).

3. A. Rubinowicz, "Zur Kirchhoffschen Beugungstheorie," *Annalen der Physik*, **73**, 4, 1924, pp. 339-364.

4. J. B. Keller, "The Geometrical Theory of Diffraction," *Symposium on Microwave Optics*, Montreal, Canada, McGill University, 1953.

5. J. B. Keller, "Geometrical Theory of Diffraction," *Journal of the Optical Society of America*, **52**, 1962, pp. 116-130.

6. I. Newton, *Opticks, or a Treatise of the Reflections, Refractions, Inflections & Colours of Light*, New York, Dover Publications, 1979 (based on the 4th edition, London, 1730).

7. A. Sommerfeld, "Mathematische Theorie der Diffraction," *Math. Ann.*, **47** (S319), 1896, pp. 317-374.

8. G. R. Harrison, R. C. Lord, J. R. Loofbourow, *Practical Spectroscopy*, Englewood Cliffs, NJ, Prentice-Hall, 1948.

9. F. M. Grimaldi, *Physico-Mathesis de Lumine, Coloribus et Iride*, Bononiae, 1665.

Introducing Feature Article Authors



Giuseppe Pelosi was born in Pisa, Italy, on December 25, 1952. He received the Laurea (Doctor) degree in physics (summa cum laude) from the University of Florence in 1976. Since 1979, he has been with the Department of Electrical Engineering of the University of Florence, where he is currently an Associate Professor of Microwave Engineering. He has been visiting scientist at McGill University, Montreal, Canada. Prof. Pelosi has been mainly involved in research in the field of numerical and asymptotic techniques for applied electromagnetics. His research interests include extensions and applications of the Geometrical Theory of Diffraction, as well as methods for radar cross section analysis of complex targets.

His current research activity is mainly devoted to the development of numerical procedures in the context of the Finite-Element Method, with particular emphasis on radiation and scattering problems. He is editor of two books: *Finite Elements for Wave Electromagnetics* (with P. P. Silvester) in 1994, for IEEE Press, and *Finite Element Software for Microwave Engineering* (with T. Itoh and P. P. Silvester) in 1996, for John Wiley & Sons. Prof. Pelosi is a member of the Italian Electrical and Electronic Association and of the Applied Computational Electromagnetics Society.

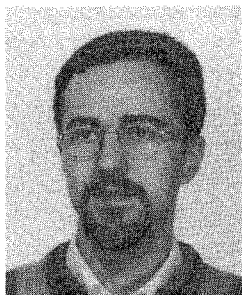

Stefano Selleri obtained his degree (Laurea), cum laude, in Electronic Engineering, and the PhD in Computer Science and Telecommunications, from the University of Florence, in 1992 and 1997, respectively. Since March, 1997, he has been a Visiting Scholar at the Laboratoire d'Electronique of the Université de Nice-Sophie Antipolis, supported by the University of Florence.

Dr. Selleri's research interests are mainly in the field of analytical and numerical techniques for applied electromagnetics, with emphasis on the application of finite-element and finite-difference methods to antenna and scattering problems. In both subject areas, he has collaborated on the development of hybrid numerical techniques, combining finite elements with other methods, and on their application to analysis and design problems.



Pyotr Ya. Ufimtsev received the MS degree from the Odessa State University, Ukraine, in 1954; the PhD degree from the Central Research Institute of Radio Industry, Moscow, Russia, in 1959; and the DSc degree in theoretical and mathematical physics from the University of St. Petersburg, Russia, in 1970. He was promoted to the scientific rank of Professorship in the Moscow Aviation Institute, Russia, in 1970.

Until 1990, he was a Head Scientist in the Institute of Radio Engineering and Electronics of the USSR Academy of Sciences, Moscow, Russia. In 1990, he was invited to join the University of California at Los Angeles (UCLA) as a Visiting Professor. Currently, he is an Adjunct Professor at UCLA, and is affiliated with Northrop-Grumman Corp., Pico Rivera, California.

Dr. Ufimtsev is the founder of the Physical Theory of Diffraction. He received the 1990 USSR State Prize, in Moscow, and the Leroy Randle Grumman Medal, in New York. He was presented with both the 20th Century Award for Achievement Medal and World Who's Who Hall of Fame Medal by the International Biographical Center, Cambridge, UK, in 1996. He is listed in the Marquis publications *Who's Who in Engineering and Science*, *Who's Who in America*, *Who's Who in the World*, as well as in the reference publications by American Biographical Institute and International Biographical Center, Cambridge, UK.

He is a member of the A. S. Popov Scientific and Technical Society (Russia), the US Electromagnetics Academy, the IEEE, and the American Institute of Aeronautics and Astronautics. 

Quick Finite Elements For Electromagnetic Waves

Giuseppe Pelosi, Roberto Coccioli, and Stefano Selleri
Artech House Books: <http://www.artech-house.com>

This practical book and the included software package helps you quickly and more easily work out challenging microwave engineering and high-frequency electromagnetic problems using the Finite Element Method (FEM). With its clear, concise text and dozens of real world application examples, the book provides a detailed description of FEM implementation, while the software provides the codes and tools needed to solve the three major types of EM problems.

The book presents a succinct overview of basic FEM concepts, outlines the capabilities and advantages of employing FEM methods, defines key finite elements and describes various hybrid methods and absorbing boundary conditions.

The included software package enables you to characterize E- and H-plane waveguide discontinuities and devices; calculate the radiation diagram on principal planes of aperture antennas modeled as 2-D structures; create geometric models using a fully functional 2-D mesh generator, analyze reflection from and transmission through inhomogeneous periodic structures, such as dichroics and photonic crystals; compute the dispersion diagram of arbitrarily shaped inhomogeneous isotropic lossless or lossy guiding structures; and analyze scattering from arbitrarily shaped inhomogeneous objects.

[Contents:] Getting Started. Tools. Microwave Guiding Structures—Characterizations. Microwave Guiding Structures—Discontinuities. Scattering and Antennas—Hybrid Methods. Scattering and Antennas—Absorbing Boundary Conditions. To Probe Further (A Selected Bibliography). CD-ROM Included.

Changes of Address

Information regarding subscription addresses is maintained by IEEE headquarters. It is *not* maintained, nor can it be changed, by any member of the *Magazine* Staff. If you are a member of the IEEE, your subscription is sent to the address in your IEEE member record. To record a change of address, contact IEEE headquarters: Member Address Records, IEEE Headquarters, 445 Hoes Lane, Piscataway, NJ 08855-1331; Tel: (908) 981-0060 or (800) 678-4333; Fax: (908) 981-9667; E-mail: address.change@ieee.org. If you are an institutional subscriber, contact IEEE Customer Service at the above address, telephone and fax numbers; E-mail: customer.service@ieee.org. Do *not* send requests to any member of the *Magazine* Staff.